

# CBR250R,RR

---

## INDEX

Maintenance Information	1
Inspection Adjustment	2
<b>ENGINE</b>	
Oil lubrication system	3
Fuel system	4
Cooling system	5
Engine attach/detachment	6
Cylinder head valve	7
Crank case	8
Cylinder, piston, crankshaft	9
Clutch, AC generator	10
Gear shift linkage	11
Transmission	12
<b>FRAME</b>	
Front wheel suspension steering	13
Rear wheel, brake, suspension	14
Braking system (Disc Brake)	15
Exhaust pipe, rear fender	16
<b>ELECTRICAL SYSTEM</b>	
Battery, alternator	17
Ignition system	18
Self starter system	19
Light, meters, switches	20
<b>SUPPLEMENTAL</b>	
CBR250R(H)	21
CBR250R(J)	22
CBR250R(K)	23
CBR250R(L)	24
CBR250R(R)	25

# CBR250R,RR

---

- **Preface**

This service manual includes the service information for Honda CBR250FOUR and CBR250R. However, only the part which differs from 250FOUR is described for 250R. Amended points from CBR250R(H) are described for CBR250R(J), so for CBR250R(K). Differences such as the outlook are not mentioned as they do not affect the maintenance.

**Section 1** - includes general cautions for maintenance work. Please use this manual after reading the section.

**Section 2** - describes about procedures for inspection and adjustments. Please conduct regular inspection by following the procedure.

**Section 3** - and onwards describes procedures for inspection and assembly/disassembly of individual parts.

In the first pages of each sections, you find the figures, maintenance information, troubleshooting charts for your convenience.

***Please note:***

***The contents may change without prior notice due to modifications of the model.***



## ● Specifications

Item		Specification		
Model Code		Honda MC14		
Length		2.000mm		
Width		0.685m		
Height		1.120m		
Wheel-base		1.370m		
Power-plant model		MC14E		
Total displacement		0.249 litres		
Fuel type		Petrol		
Vehicle empty weight	Front Axle	77 kg		
	Rear Axle	76 kg		
	Total	153 kg		
Maximum capacity		2 people		
Vehicle gross weight	Front Axle	97 kg		
	Rear Axle	166 kg		
	Total	263 kg		
Tyre	Front	100/80 – 17 52H		
	Rear	130/70 – 17 62H		
Minimum clearance		0.140m		
Braking Distance		14.0m (50km/h)		
Minimum turning radius		2.6m		
Powerplant	Starter type		Electric	
	Type of engine		Petrol 4 Stroke	
	Cylinders		2 abreast	
	Configuration		Inline 4 cylinder	
	Valve operation		DOHC	
	Bore X Stroke		48.5 x 33.8mm	
	Compression ratio		11.0	
	Compression Pressure		13.0kg/cm <sup>2</sup> - 400rpm	
	Maximum output		45 PS / 14,500 rpm	
	Maximum torque		2.5 kg-m / 10,500 rpm	
	Valve operation time	Intake Valve	Open	10° BTDC (1mm lifted)
			Close	40° ABDC (1mm lifted)
		Exhaust Valve	Open	30° BBDC (1mm lifted)
			Close	10° BTDC (1mm lifted)
	Valve Clearance		In	0.16mm (cold)
			Out	0.23mm (cold)
	Idle Speed		1,500rpm	
	Lubrication		Forced Pressure	
	Oil filter		Total flow	
Oil pump		Trochoid Rotor		
Oil capacity		2.7 litres		
Cooling System		Liquid cooled		



## ● Specifications

Item		Specification			
Fuel system	Air filter	Type	Viscous Paper		
	Carburetor	Fuel Capacity	14.0 litres		
		Carburettor	VG01		
		Piston size	28mm		
		Venturi diameter	25mm		
	Ignition	Ignition Timing	20° BTDC / 1,500 rpm		
		Spark Plug	NGK	C8EH - 9, C9EH - 9	
			ND	U24FE 9, U27FE 9	
		Plug Gap	0.8 - 0.9 mm		
		Battery	12V 8AH		
	Clutch	Type	Multi-wet plate		
		Operation	Mechanical		
	Transmission	Primary Reduction	2.966		
		Gear ratio	Type	Constant Mesh	
			1st	2.733	
			2nd	2.000	
			3rd	1.590	
4th			1.333		
5th			1.153		
6th	1.035				
Reduction : First	Gear type	Chain			
	Reduction ratio	3.071			
Tyre Pressure	Front	26° 00'			
	Rear	97mm			
Steering system	Steering stem angle	Left	35°		
		Right	35°		
Braking system		Front	Hydraulic Disc		
		Rear	Hydraulic Disc		
Shock absorbing system Frame	Suspension	Front wheel	Telescopic fork		
		Rear wheel	Swing arm		
		Type	Diamond		

## Structure Description

### Engine

The vehicle is equipped with a water cooled inline 4 cylinder engine. The engine is inclined forward- 35° This inclination enables an improved straight intake manifold port, which allows smooth flow of air-fuel mixture gas.

Gear drive system was applied to the cam shaft instead of chain drive system. The gear system is optimised for high speed operation.

In order to provide smooth valve operation at high speed, the engine has lower shim design. Also, carbon hardened connecting rods used to reduce friction loss.

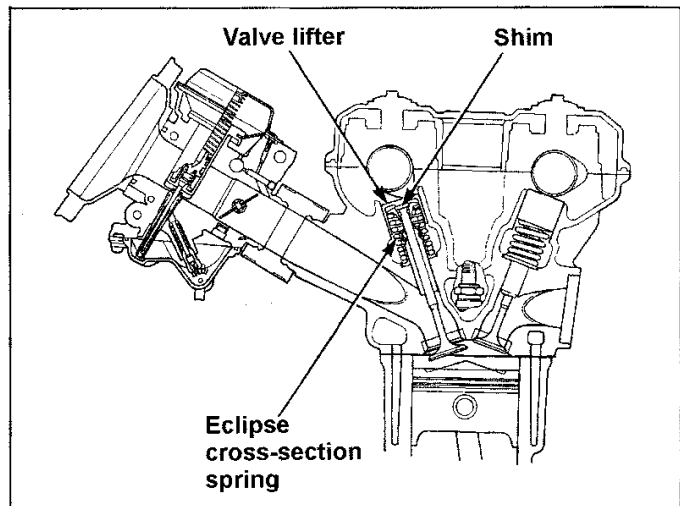
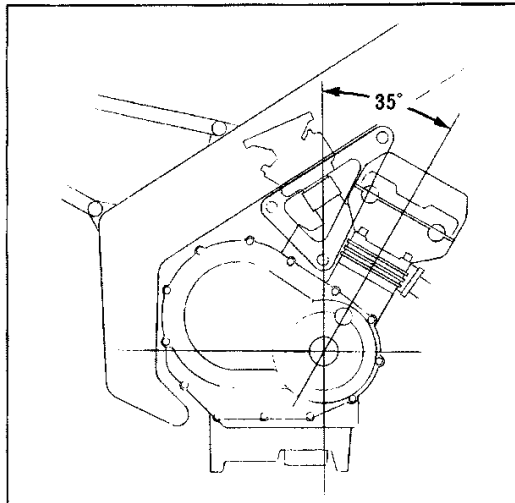

To provide smooth valve operation in high speed, the valve spring was computer designed to endure higher stress.

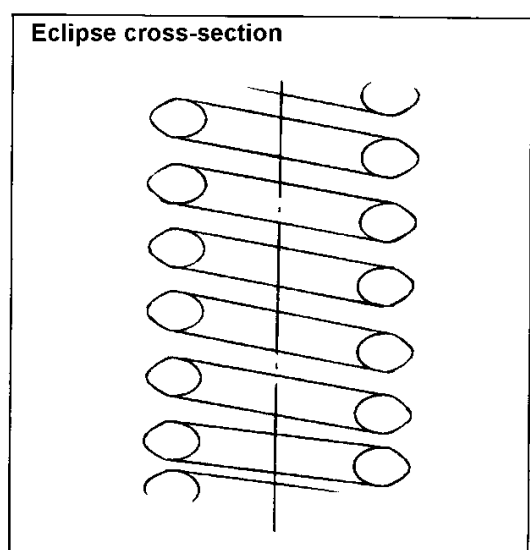
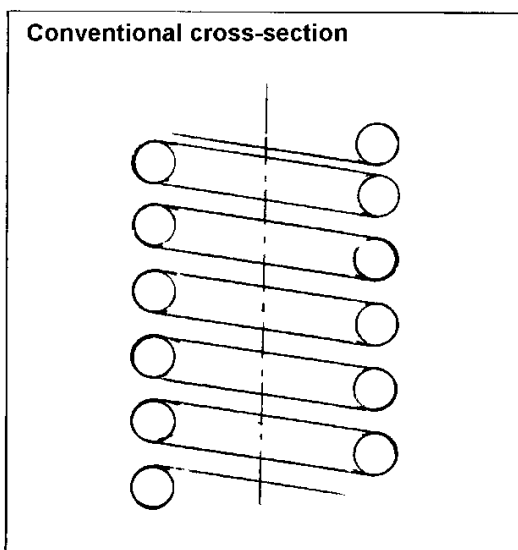

In order to reduce friction loss and to operate valves in accurate timing, gear driven cam system is applied.

The figure below shows the linkage between the crankshaft and the cam gears.

The crankshaft power is transmitted to the cam gear through the primary driven gear (clutch outer gear), which is on the same axle for the transmission main shaft.

This mechanism is quite different from the V-gear drive system, which the crankshaft directly drives cam gears.

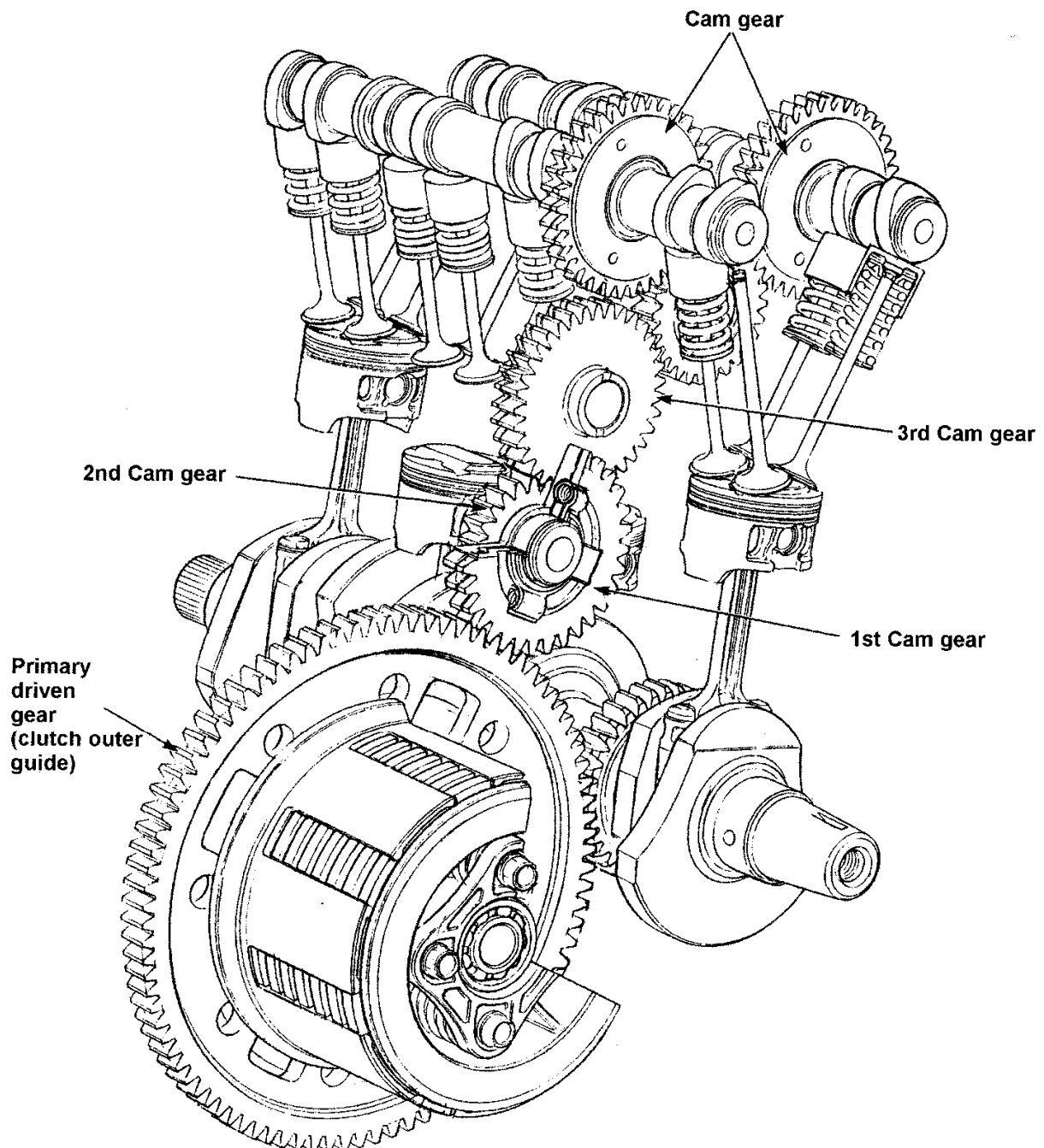

## Ignition System

A newly designed digital ignition unit with a built-in micro computer provides best ignition throughout its operating speed range.

A pulse rotor has seven projections. From (1) – (7) have 45° separation and 90° for (7) to (1). The engine rpm and crank position for each cylinder are detected from the relative position of the seven projections and two pulser coils. The two pulser coils are installed so as to have 15° inclination from level line for PC2 end, compared to PC1. This angular offset is to detect crank positions.

The time when the pulse rotor's projection passes the PC1 pulser coil is referred as "O-reference". By detecting the time required to have the projection at the pulser coil again, the engine rpm is determined and the micro computer determines ignition timing.

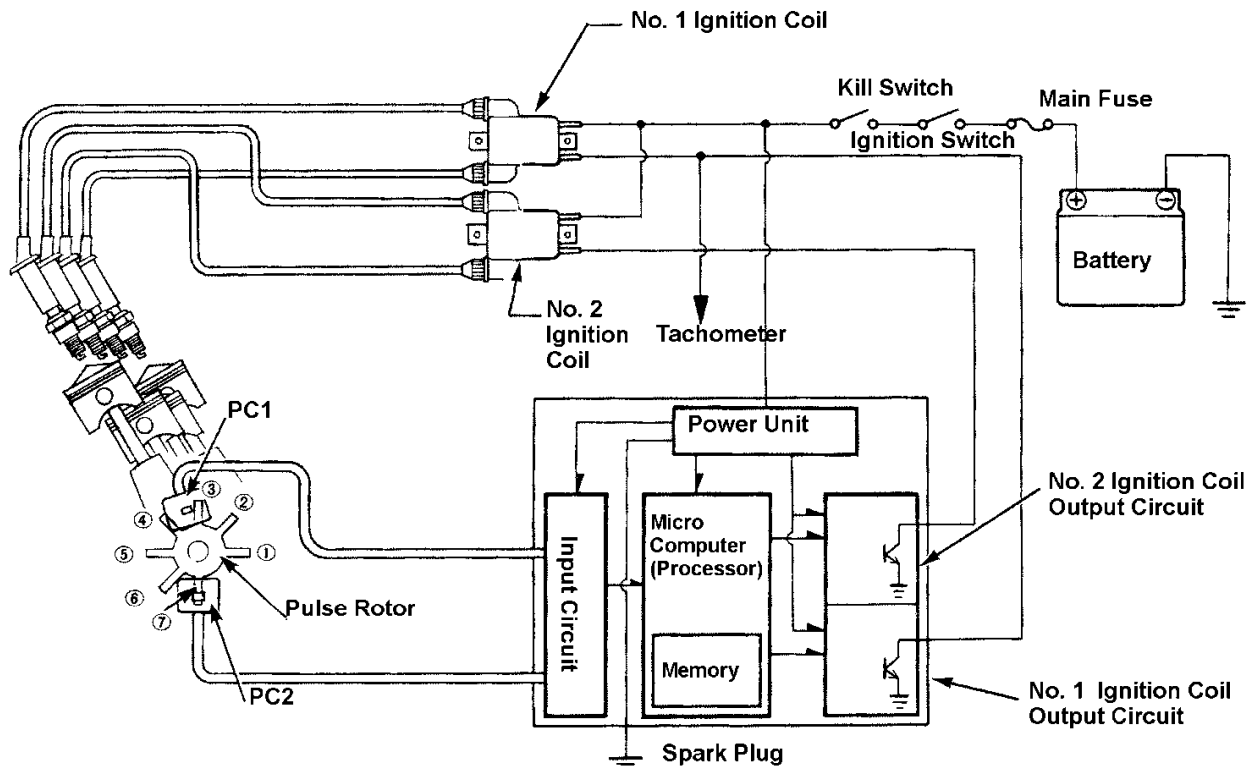

## General Caution

- Replace gaskets, O-Rings, circlips and cotter pins when they are removed.

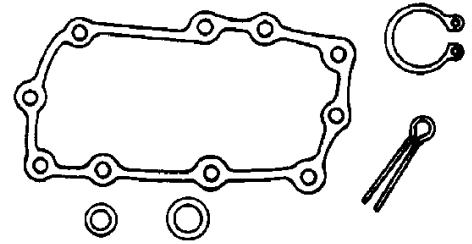

- When screwing, temporarily tighten screws/bolts. Screw bigger diameter first, then smaller diameter. Inner ones first, then outer ones. Tighten in criss-cross way whenever possible. Apply designated torque.

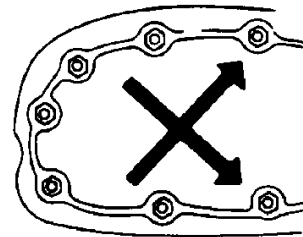

- Use genuine Honda or recommended parts, lubricants, and other products.

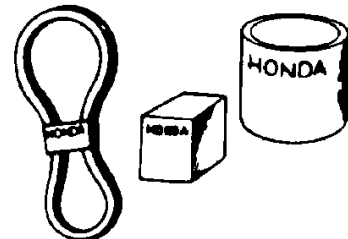

- Use special / common tools as instructed.

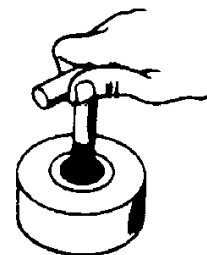

- Disassembled parts are to be cleaned before the inspection/measurement. Apply oil to contact area when installing them.

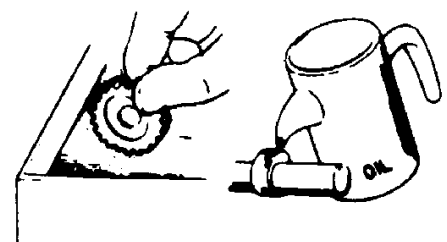

- Apply grease or equivalent to designated parts.

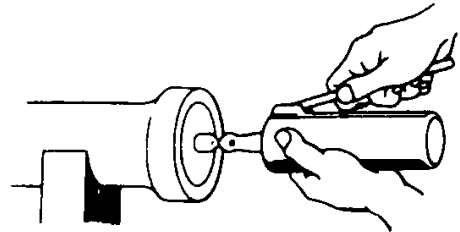

- After assembling, check the operation and fittings.

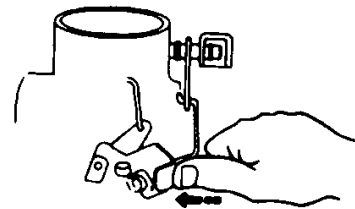

- When multiple people are working at the same time, always confirm each other's safety.

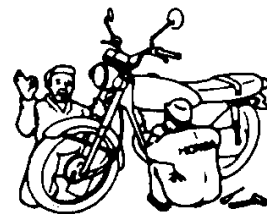

- Disconnect (-) lead from the battery prior to servicing the vehicle.
- Do not touch the frame with a wrench or any other metal tools.

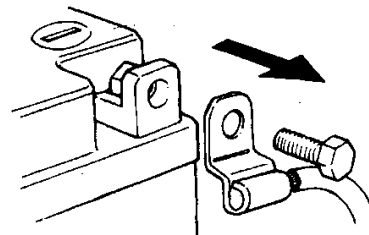

- After servicing the vehicle, check each connection, fittings and routing.
- If the battery has been disconnected, connect (+) lead first.
- Apply grease to the terminals after connecting leads.
- Attach covers to the terminals.

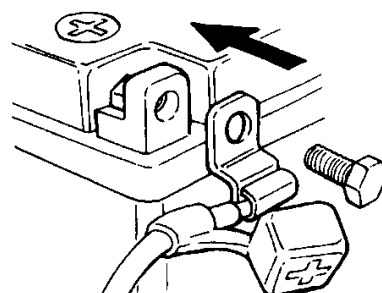

- If a fuse has blown, inspect and fix the cause and install the new fuse with the correct capacity.

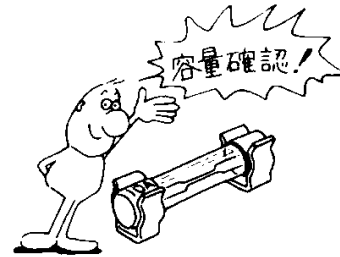

- Apply covers to terminals after servicing.

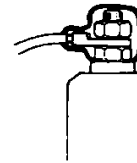

- When disconnecting locked couplers, unlock before disconnecting.

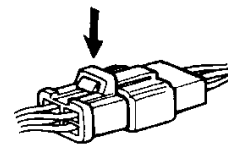

- When disconnecting couplers, hold the coupler body. Do not pull the wire harness.



- Before connecting couplers, make sure there is no damage or any abnormalities on the terminals.

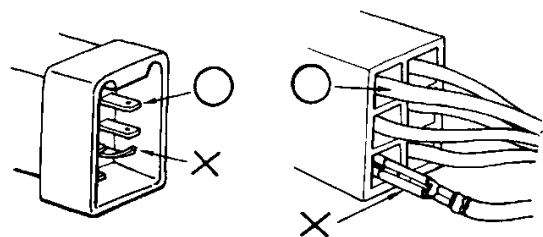

- Firmly insert couplers.
- Check couplers are locked if the couplers have locks.
- Check all harnesses are connected.

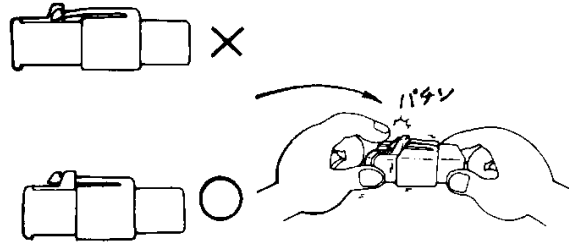

- Coupler covers should cover whole coupler unit without any peels.

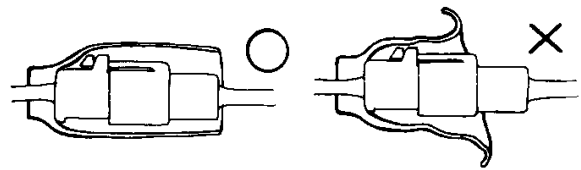

- Connector covers should not be damaged and female terminals should not be loose.

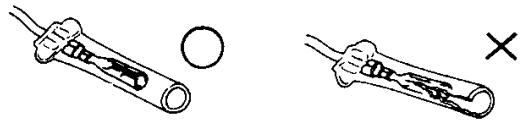

- Firmly secure the connectors.
- Covers should wrap whole terminals.
- Open end of the covers should not face upwards.

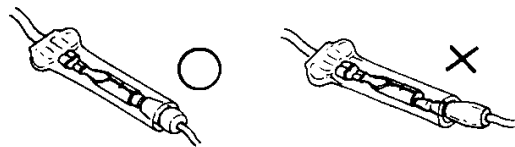

- Fix wire steps to designated position on the frame.
- Clamp wire harnesses at the coated area when aluminium straps are used.

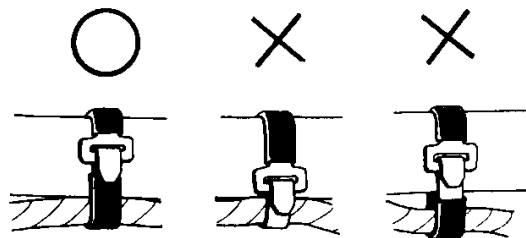



- Make sure wire harnesses are properly clamped.

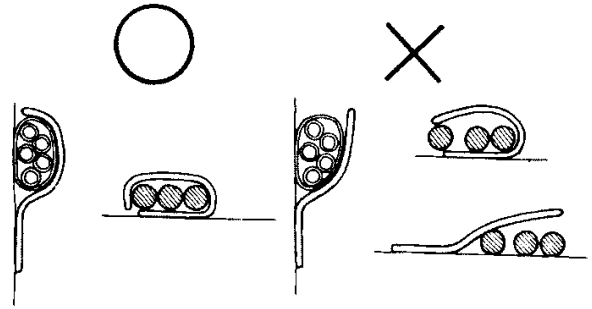

- Do not clamp to the welded side when weld-clamping.

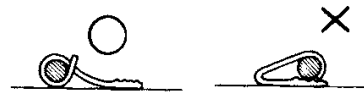

- Clamp wire harnesses so as to keep them away from moving parts.

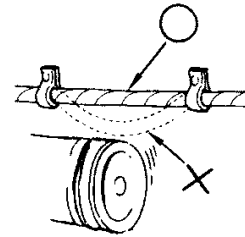

- Clamp wire harnesses so as to keep them away from heated parts.

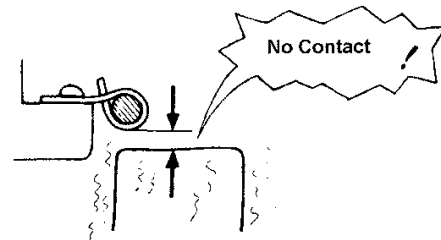

- Wire harnesses are to be routed to avoid body edges or sharp edges.

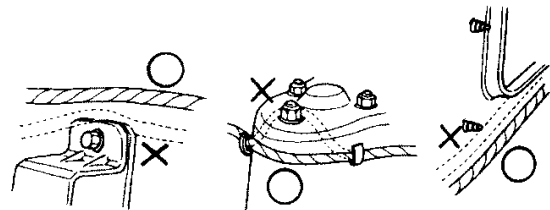

- Do not let wire harnesses to touch bolt/screw heads and their ends.

- Do not apply excessive tension / slack to the wire harnesses.

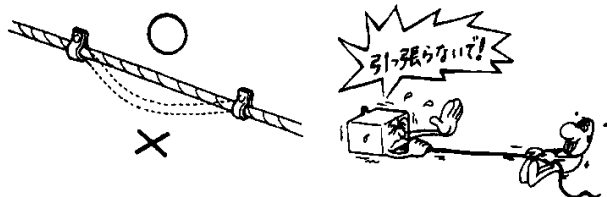

- If there is no other alternatives but to route wire harnesses through sharp edges, protect the part with tubes or tape.

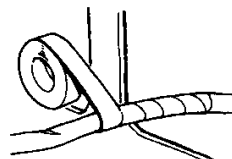

- Firmly set grommets if available.

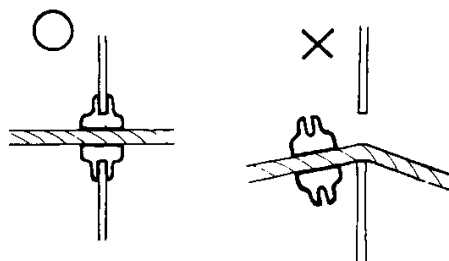

- Do not unwrap wire harnesses.
- Wrap the wire harness with adhesive vinyl tape if it is unwrapped.

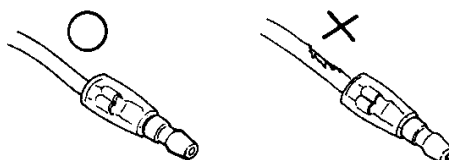

- Do not catch wire harnesses when installing parts.

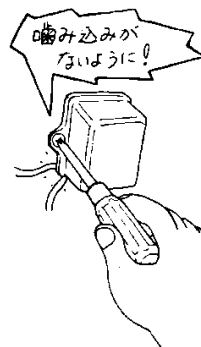

- Do not twist wire harnesses.

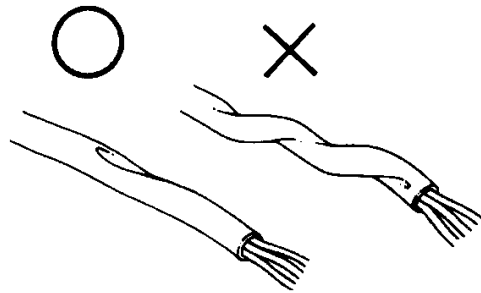

- Make sure wire harnesses are not over-tensioned or over-slack when the handlebar is fully turned to either side. Also, they should not have any sharp bending, catching or contact with sharp edges.

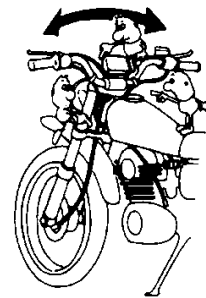

- Read instructions when using a multi meter, and follow the instruction on the service manual.
- Do not drop or throw parts.

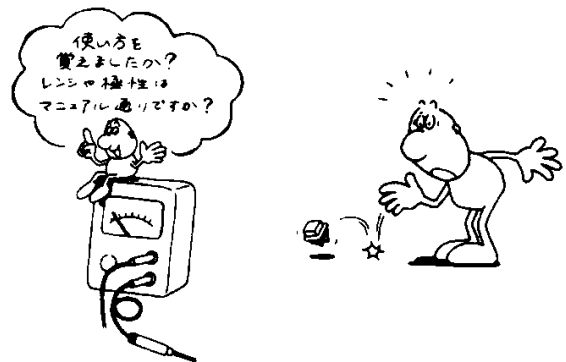







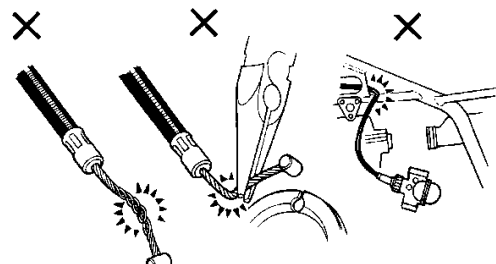









- If rust is forming on the terminal, remove with sandpaper before re-connecting.



- Do not twist or sharply bend cables. Such deformations or damages may cause failure.

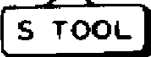

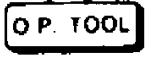
Symbol	Meaning	Symbol	Meaning
	<p>Danger:</p> <p>Its neglect may lead to serious injuries.</p>		<p>Important:</p> <p>Its neglect may lead to minor injury or damaging the parts.</p>
			<p>General caution:</p> <p>Tips of the work</p>

Symbol	Meaning	Symbol	Meaning
	<p>Apply oil:</p> <p>Unless specified, use designated or recommended oil.</p>		Apply sealant
	<p>Apply Molybdenum solution:</p> <p>The solution is a mixture of engine oil and Molybdenum grease at</p>		<p>Replace with new parts whenever disassembled.</p>
	<p>Apply multi-purpose grease. (Lithium soap based NLG #2 equivalent).</p> <p>Example: SHELL Albania EP-2</p>		<p>Apply brake fluid.</p> <p>Use recommended grade (DOT4)</p>
	<p>Apply Molybdenum grease (3% or more Molybdenum, NLGI#2 equivalent)</p> <p>Mitsubishi multi purpose M2 Dow Corning Molycoat BR – 2 PLUS</p>		Apply recommended cushion oil.
	<p>Apply Molybdenum paste. (40% or more Disulphide Molybdenum. NLGI#2 equivalent).</p> <p>Local paste Molycote G-n Paste (Dow Corning)</p>		Use exclusive tools
	<p>Apply silicone grease</p> <p>Silicone grease G40M (ShinEtsu)</p>		<p>O.P. (Option) tool.</p> <p>Refer to parts list as these tools are considered to be parts.</p>
	<p>Apply screw locker.</p> <p>Use medium class unless specified.</p>	-> 3-1	Reference pages.

## Tightening Torque

### • Engine

Part Name	Qty	Screw Dia	Tightening Torque kg-m	Notes
Cylinder head cover (special bolt)	6	6	0.8 - 1.2	
Cam shaft holder (flange bolt)	16	6	1.2 - 1.6	
Cylinder head (flange bolt)	12	7	1.7 - 2.1	Apply oil
Spark Plug	4	10	1.0 - 1.2	
Con rod (con rod bolt/nut)	8	-	1.5 - 1.9	Apply oil
Gear train holder nut	2	8	1.8 - 2.2	
AC generator fly wheel	1	10	8.0 - 9.0	UBS
Starter Clutch	1	10	7.0 - 8.0	UBS
Clutch Centre	1	20	6.0 - 7.0	
Oil pump driven sprocket (flange bolt)	1	6	1.3 - 1.7	Apply screw lock
Oil Pressure Switch	1	-	1.0 - 1.4	Apply screw lock
Neutral Switch	1	10	1.0 - 1.4	
Oil filter centre bolt	1	20	1.5 - 2.0	
Drain plug bolt	1	14	3.5 - 4.0	
Crankcase attachment bolt (6mm)	16	6	1.0 - 1.4	Apply oil
(8mm)	11	8	2.1 - 2.5	Apply oil
Cover attachment bolt (6mm )	25	6	0.8 - 1.2	
Shift drum center (Shifter pin)	1	-	2.1 - 2.5	Apply screw lock

### • Frame

Part Name	Qty	Screw Dia	Tightening Torque kg-m	Notes
Handle attachment Bolt	2	8	2.5 - 3.0	
Brake Disc Bolt	12	8	3.7 - 4.3	
Front accelerator nut	1	14	5.5 - 6.5	
Front accelerator holder nut	4	8	1.8 - 2.5	U-Nut
Caliper bracket bolt	4	8	2.4 - 3.0	
Master cylinder holder nut	2	6	1.0 - 1.4	
Front fork socket bolt	2	8	1.5 - 2.0	
Bottom bridge bolt	2	10	3.0 - 4.0	
Top bridge bolt	2	7	0.9 - 1.3	
Front Fork bolt	2	31	1.5 - 3.0	
Steering adjusting bolt	1	26	2.0 - 2.4	
Steering stem bolt	1	24	9.0 - 12.0	
Driven sprocket nut	6	8	2.8 - 3.4	
Rear accelerator bolt	1	16	8.0 - 10.0	U-Nut
Rear cushion lower joint locking nut	1	12	3.8 - 6.0	Apply screw locker
Rear cushion upper bolt	1	10	5.0 - 6.0	U-Nut
Rear cushion lower bolt	1	10	5.0 - 6.0	U-Nut
5.0 - 6.0	1	10	5.0 - 6.0	U-Nut
Con rod bolt (Custom arm side)	1	10	5.0 - 6.0	U-Nut
(Frame side)	1	10	5.0 - 6.0	U-Nut
Rear fork pivot adjusting bolt	1	26	1.0 - 2.0	
Rear fork pivot locking nut	1	26	6.0 - 7.0	
Rear fork pivot nut	1	14	6.0 - 7.0	U-Nut

Part Name	Qty	Screw Dia.	Tightening Torque kg-m	Notes
Hanger pin	4	10	1.5 - 2.0	
Hanger pin plug	4	10	0.1 - 0.2	
Brake hose attachment bolt	4	10	2.5 - 3.5	
Brake hose tightening bolt	1	10	3.0 - 4.0	Right side under a bottom bridge
Exhaust pipe joint nut	8	6	0.8 - 1.2	
Muffler attachment bolt	1	8	2.4 - 3.0	
Change pedal	1	6	1.0 - 1.4	
Engine mount bolt	8	10	4.5 - 5.5	
Engine hanger bracket	4	10	3.5 - 4.5	
Sub frame	4	10	4.5 - 5.5	
Side stand bracket	2	8	2.5 - 3.0	
Step holder	4	8	2.5 - 3.0	
Tandem step holder	4	8	2.5 - 3.0	
Ignition switch	2	8	2.5 - 3.0	
Thermostat case	2	6	1.0 - 1.4	
Radiator upper stay	2	6	1.0 - 1.4	
Radiator grill	2	6	0.8 - 1.2	
Fuel cock	1	22	2.0 - 2.5	
Fuel tank attachment nut	1	6	0.8 - 1.2	
Fuel tank attachment bolt	1	8	1.8 - 2.5	
Air cleaner case (step bolt)	6	5	0.6 - 1.0	
Air cleaner duct	1	6	0.5 - 0.8	
Sub air cleaner	1	6	0.5 - 0.8	
Fairing	6	6	0.7 - 1.1	
Fairing inside cover	4	6	0.6 - 1.0	
Head light	4	6	0.3 - 0.5	
Fairing stay	2	10	3.0 - 4.0	
Meter	2	6	0.8 - 1.2	
Cooling fan switch	1	16	2.4 - 3.2	Apply sealer
Front fender (6mm bolt)	4	6	0.8 - 1.2	
(6mm bis)	2	6	0.7 - 1.1	
Rear fender A	4	6	0.7 - 1.1	
Rear fender B	5	6	0.8 - 1.2	
Tail light	2	6	0.8 - 1.2	
Starter motor terminal cable	1	6	0.8 - 1.2	
Front direction indicator	2	5	0.35 - 0.50	
Horn stay	1	6	0.8 - 1.2	

- For the parts not specified in the above tables, use the following standards.

- **Standard Tightening Torque** SH (Small Head) Bolt: 8mm flange head 6mm bolt

Type of bolt/nut	Torque kg-m	Type of bolt/screw/nut	Torque kg-m
5mm bolt/nut	0.45 - 0.6	5mm screw	0.35 - 0.5
6mm bolt/nut	0.8 - 1.2	6mm screw, 6mm flange bolt	0.7 - 1.1
8mm bolt/nut	1.8 - 2.5	6mm flange bolt/nut	1.0 - 1.4
10mm bolt/nut	3.0 - 4.0	8mm flange bolt/nut	2.4 - 3.0
12mm bolt/nut	5.0 - 6.0	10mm flange bolt/nut	3.5 - 4.5

- **Exclusive / Common Tools**

• **New Exclusive tools**

Name of the tool	Tool Number	Application	Section in the Manual
Compression gauge attachment	07GMJ-KT70100	Cylinder compression meas.	2
Clutch center holder	07GMB-KT70100	Clutch assembly/disassembly	10
Valve spring compressor attachment	07GME-KT70200	Valve assembly/disassembly	7
Tappet hole protector	07GME-KT70200	Valve assembly/disassembly	7
Valve guide remover (4mm)	07GMD-KT70100	Valve guide assembly/disassembly	7
Socket wrench (Dodecagon)	07GMA-KT70100	Cylinder head 7mm bold (dodecagon) attach/detachment	7
Needle bearing remover	07GMA-KT70200	Rear fork L-bearing detachment	14
Lock nut wrench	07GMA-KT70200	Rear fork attach/detachment	14

• **Existing exclusive tools**

Name of the tool	Tool number	Application	Section in the manual
Oil pressure gauge attachment	07510-4220100	Oil pressure measurement	3
Steering stem attachment	07916-3710100	Adjust nut attach/detachment	13
Bearing remover	07936-3710300	Detachment of needle bearings of rear fork and suspension linkage, main shaft L-bearing	14
- Remover handle	07936-3710100		8
- remover sliding weight	07741-00110201		
Driver attachment (28X30mm)	07946-1870100	Attachment of rear fork L-bearing	14
Steering stem driver	07946-MB00000	Inner race attachment	13
Driver shaft	07946-MJ00100	Rear fork bearing detachment	14
Fork seal driver attachment	07947-KA20200	Front fork assembly	13
Ball race remover set	07946-KM90000	Ball race attach/detachment	13
- driver shaft assy(incl. nut)	07946-KM90300		
- assembly base			
- driver attachment A	07946-KM90600		
- driver attachment B	07946-KM90100		
- bearing remover A	07946-KM90200		
- bearing remover B	07946-KM90400 07946-KM90500		
Rear cushion compressor attachment	07959-MB10000	Rear cushion Assembly/disassembly	14
Valve guide reamer	07964-8840000	Valve guide clean/finish	7
Snap ring pliers	07914-3230001	Snap ring attach/detachment	15
Piston ring compressor	07955-ZG00000	Piston assembly	9

• **Common Tools**

Name of the tool	Tool number	Application	Section in the manual
Float level gauge	07401-0010000	Carburettor float level measurement	4
Lock nut wrench (26x30mm)	07716-0020203	Clutch lock nut attach/detachment	10
Extension bar	07716-0020500	Attach to the lock nut wrench	10,13
Lock nut wrench (30x32mm)	07716-0020400	Steering stem nut attach/detachment	13
Fly wheel holder	07725-0040000	Fly wheel attach/detachment	10
Rotor puller	07733-0020001	Fly wheel detachment	10
Outer driver (32x35mm)	07746-0010100	Front wheel R-bearing, Rear fork R-bearing attachment	13 14
Outer driver (37x40mm)	07746-0010200	Rear wheel bearing, main shaft, L-bearing attachment	14 8
Outer driver (42x47mm)	07746-0010300	Front wheel L-bearing driven flange bearing attachment	13 14
Outer driver (24x26mm)	07746-0010700	Suspension linkage needle bearing attachment	14
Pilot (15mm)	07746-0040300	Front wheel bearing, rear fork R-bearing attachment	13 14
Pilot (17mm)	07746-0040400	Rear wheel, suspension linkage, driven sprocket, main shaft L-bearing attachment	8 14
Pilot (22mm)	07746-0041000	Rear fork L-bearing	14
Bearing remover head (15mm)	07746-0050400	Front wheel bearing removal	13
Bearing remover shaft	07746-0050100	Wheel bearing removal	13,14
Bearing remover head (17mm)	07746-0050500	Rear wheel bearing removal	14
Fork seal driver	07747-0010100	Front fork assembly	13
Driver handle A	07749-0010000	Bearing attachment	8,13,14
Valve spring compressor	07959-3290001	Rear cushion assembly/disassembly	14



- **Measurement tools**

Name of the tool	Tool number	Application	Section in the manual
Digital circuit multimeter (KOWA)	07411-002000	Kowa circuit multimeter (TH-5H) Or Sanwa's 07309-0020000 <b>*Use the multimeter to check the charge of MF battery.</b>	17,18,19,20
Oil pressure gauge	07506-3000000	Oil pressure measurement	3
Vacuum gauge	07404-0030000	Carburettor synchronizing adjust	4
Compression gauge	07305-0010000	Cylinder compression meas.	2

### Valve seat cutting tools

Name of the tool	Tool number	Application	Section in the manual
Sheet surface cutter (20.5mm)	07780-0011000	45°IN) valve sheet adjustment	7
Sheet surface cutter (17mm)*	07GMH-KT70500	(45°EX) valve sheet adjustment	7
Plane cutter (17mm)*	07GMH-KT70100	(32°IN) valve sheet adjustment	7
Plane cutter (17mm)*	07GMH-KT70200	(32°EX) valve sheet adjustment	7
Inner surface cutter (20.5mm)	07780-0014300	(60°IN) valve sheet adjustment	7
Inner surface cutter (17mm)*	07GMH-KT70400	(60°EX) valve sheet adjustment	7
Cutter holder (4mm)*	07GMH-KT70300	Attach the cutter	7

\*Newly-organized tools

- Lubrication

## Engine Components

Part	Recommended Oil Grade
Inside cylinder head rev. part and contact surface Inside crankcase rev. part and contact surface.	SAE10W-40 or 20W-50.

## Frame

Unless specified, use multi-purpose grease for greasing symbol.

Apply oil or grease to any other moving parts not specified here to prevent noise and extend and endurance.

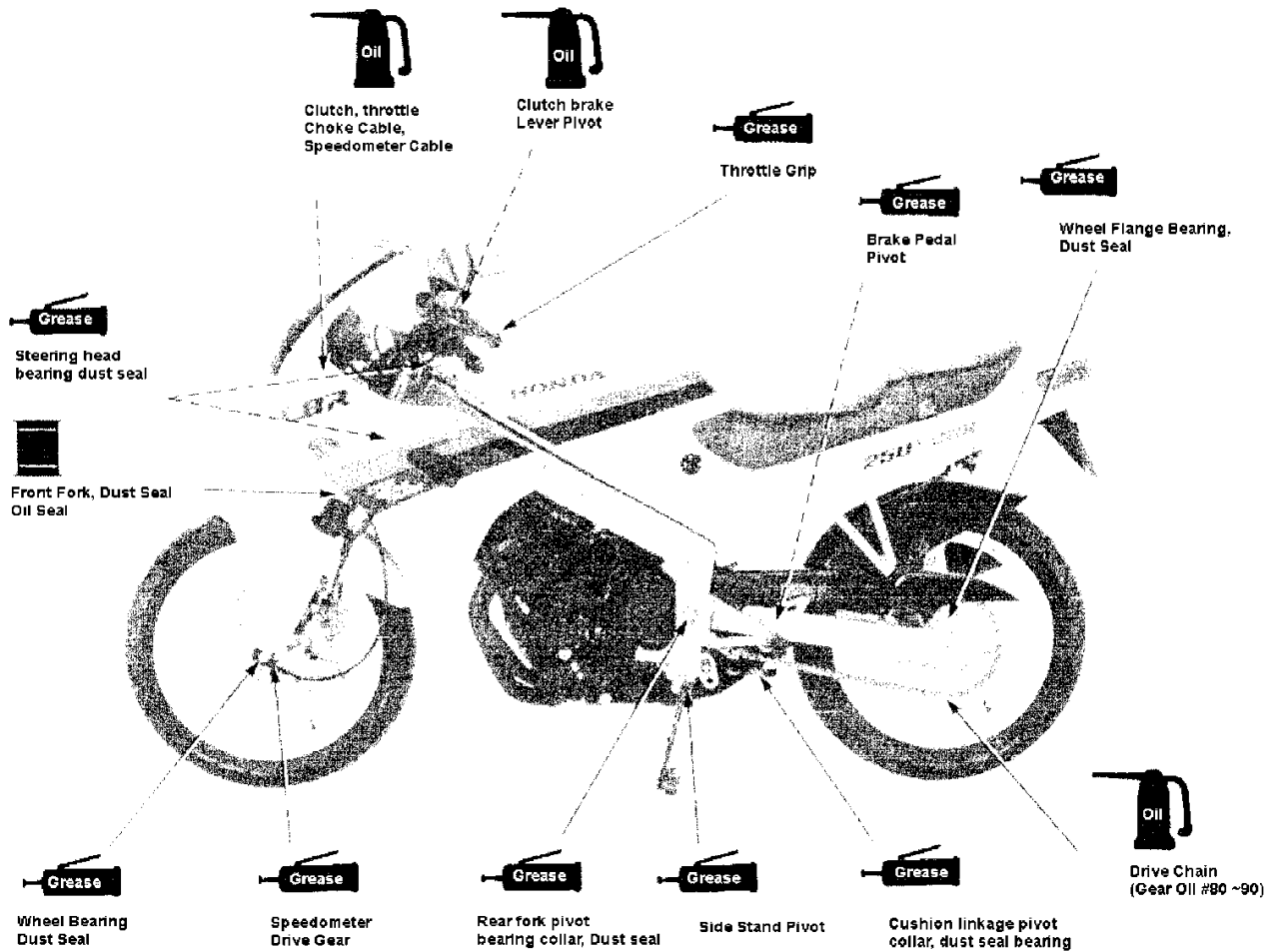

• Electrical Circuits

- 1. Pilot Lights
- 2. L-Winker pilot light
- 3. High beam pilot light
- 4. Neutral pilot light
- 5. Oil pressure light
- 6. R-Winker pilot light

- FUSE 10A
- 1. Fan motor
  - 2. Marking
  - 3. Front position tail
  - 4. Head light
  - 5. Head light
  - 6. Neutral, oil temp
  - 7. Winker, F.R.stop

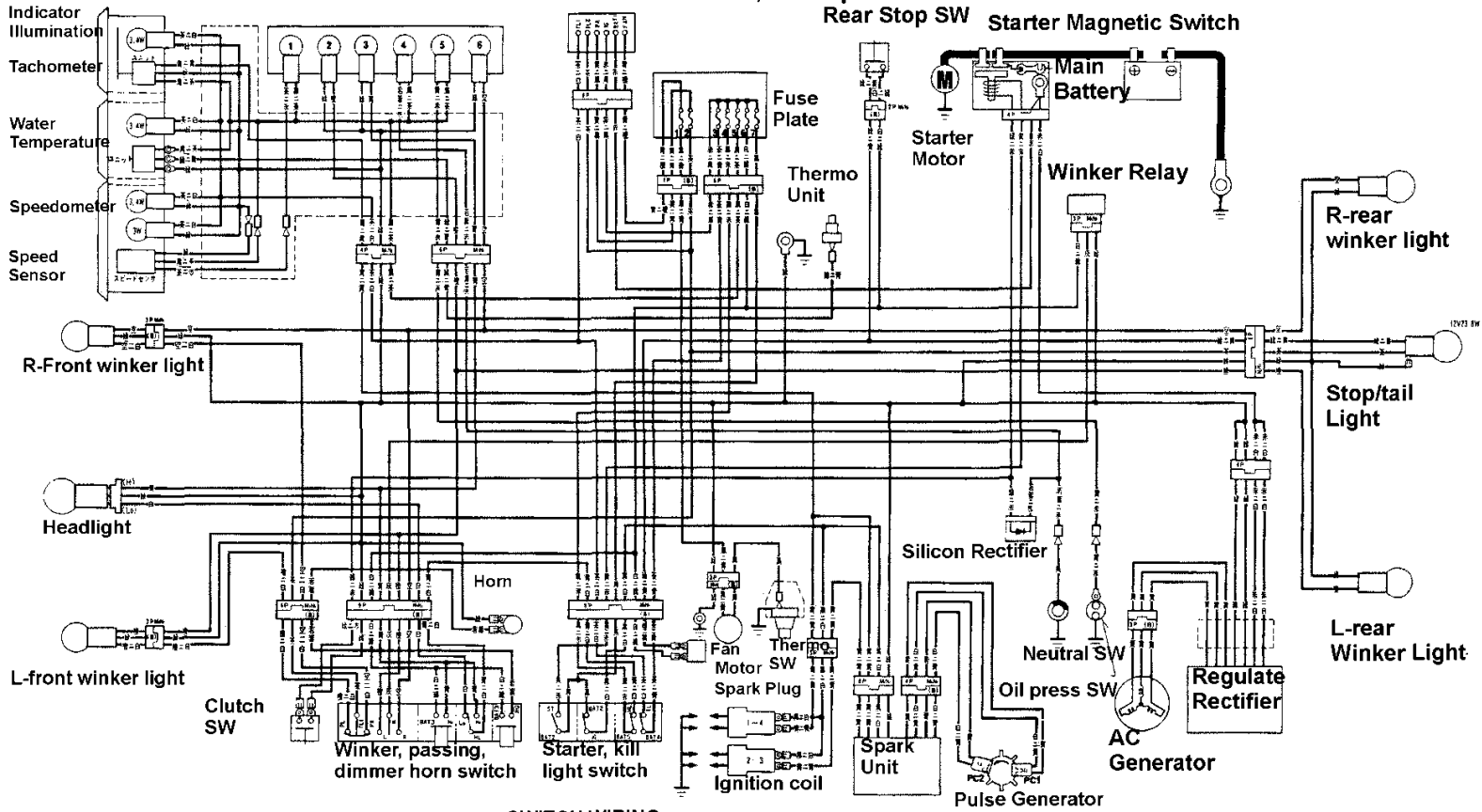

SWITCH WIRING

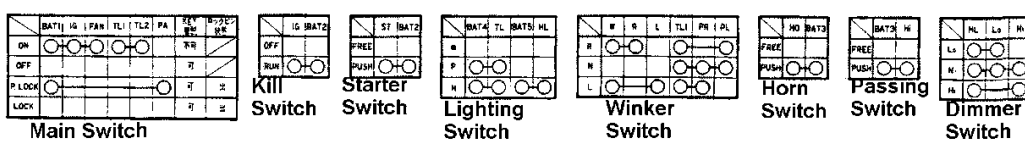

0030Z--KT7--0000

Winker---Direction---Indicator

• **Wiring**

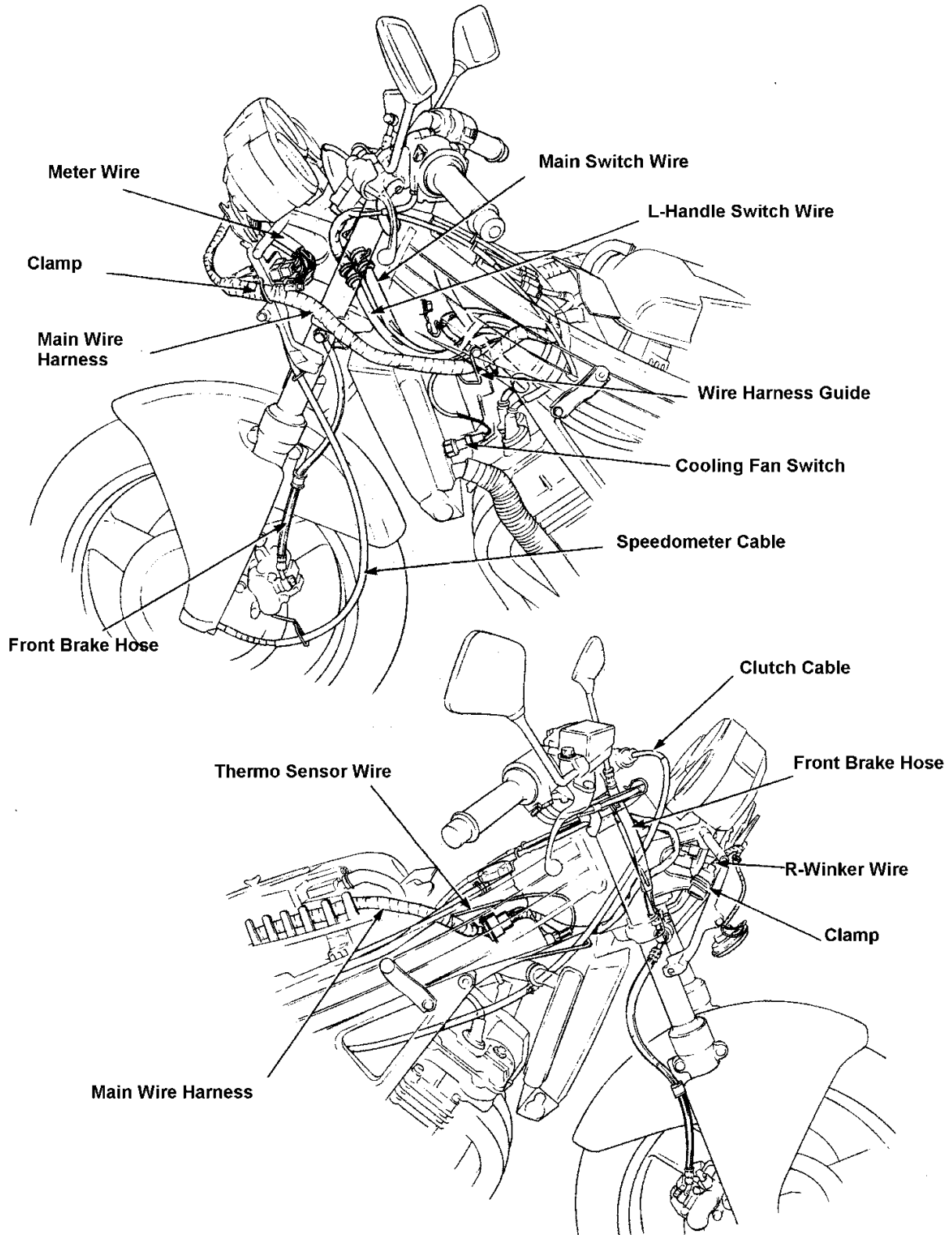

- Wiring

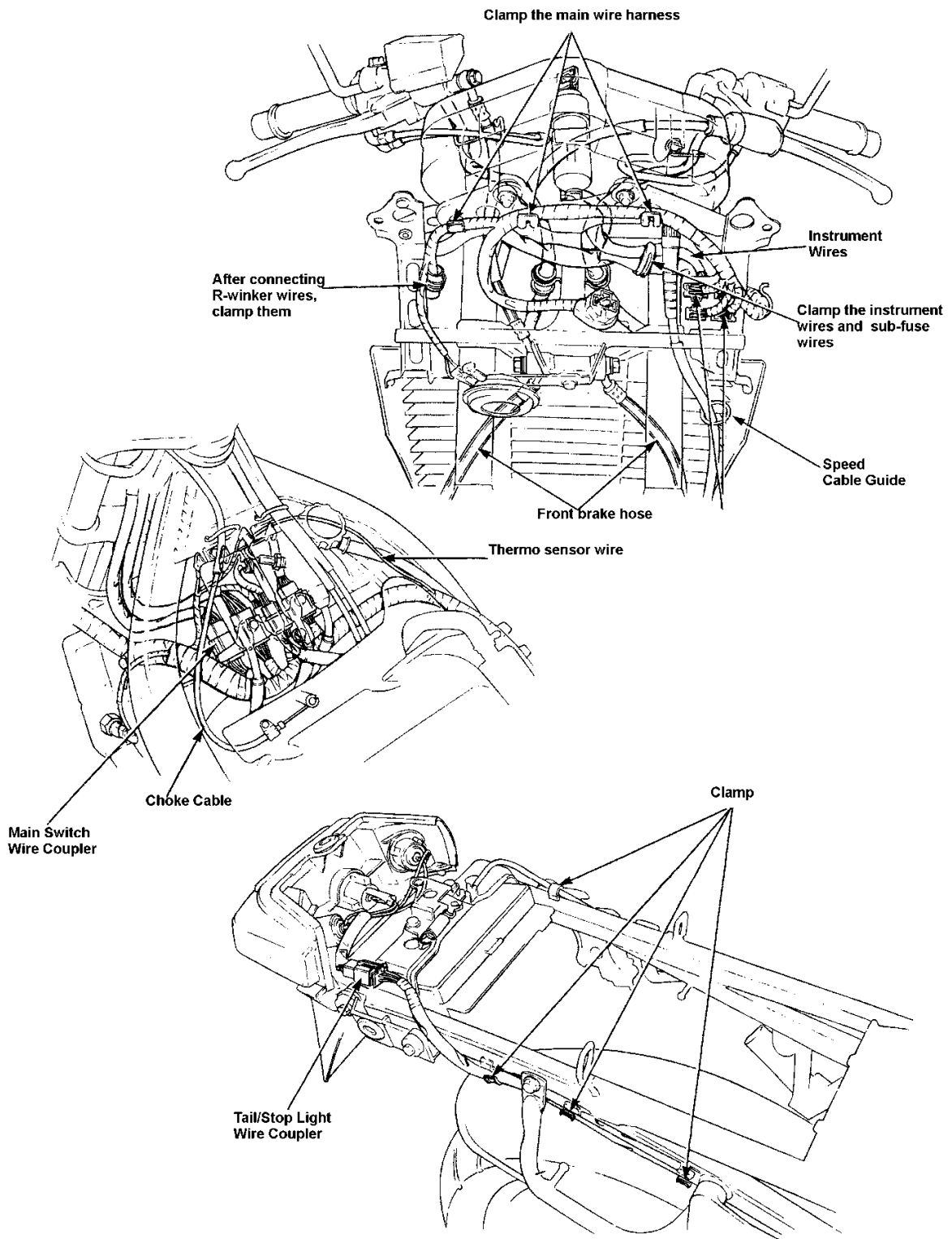

- Wiring

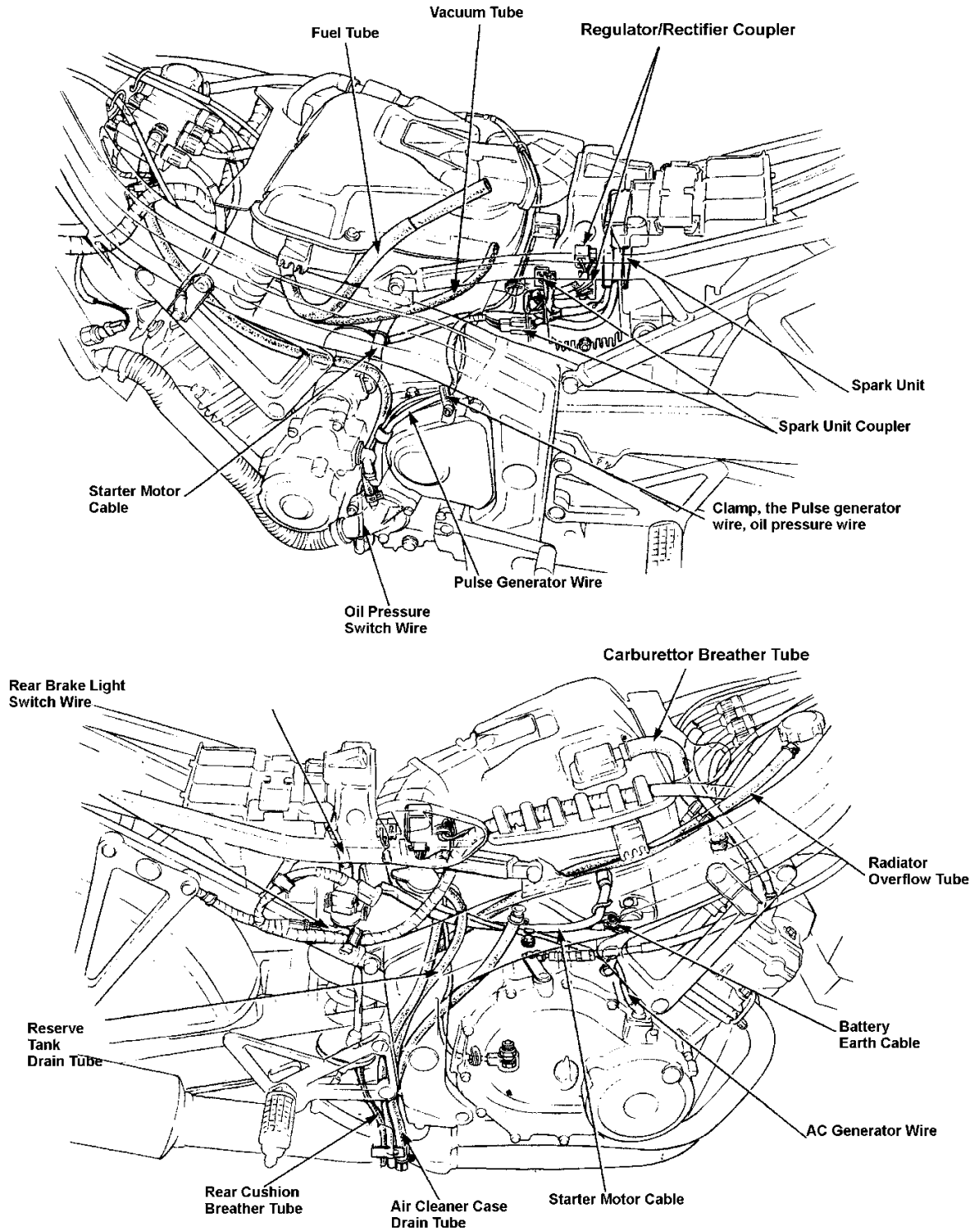

- Troubleshooting
- Failure/Difficult to Start

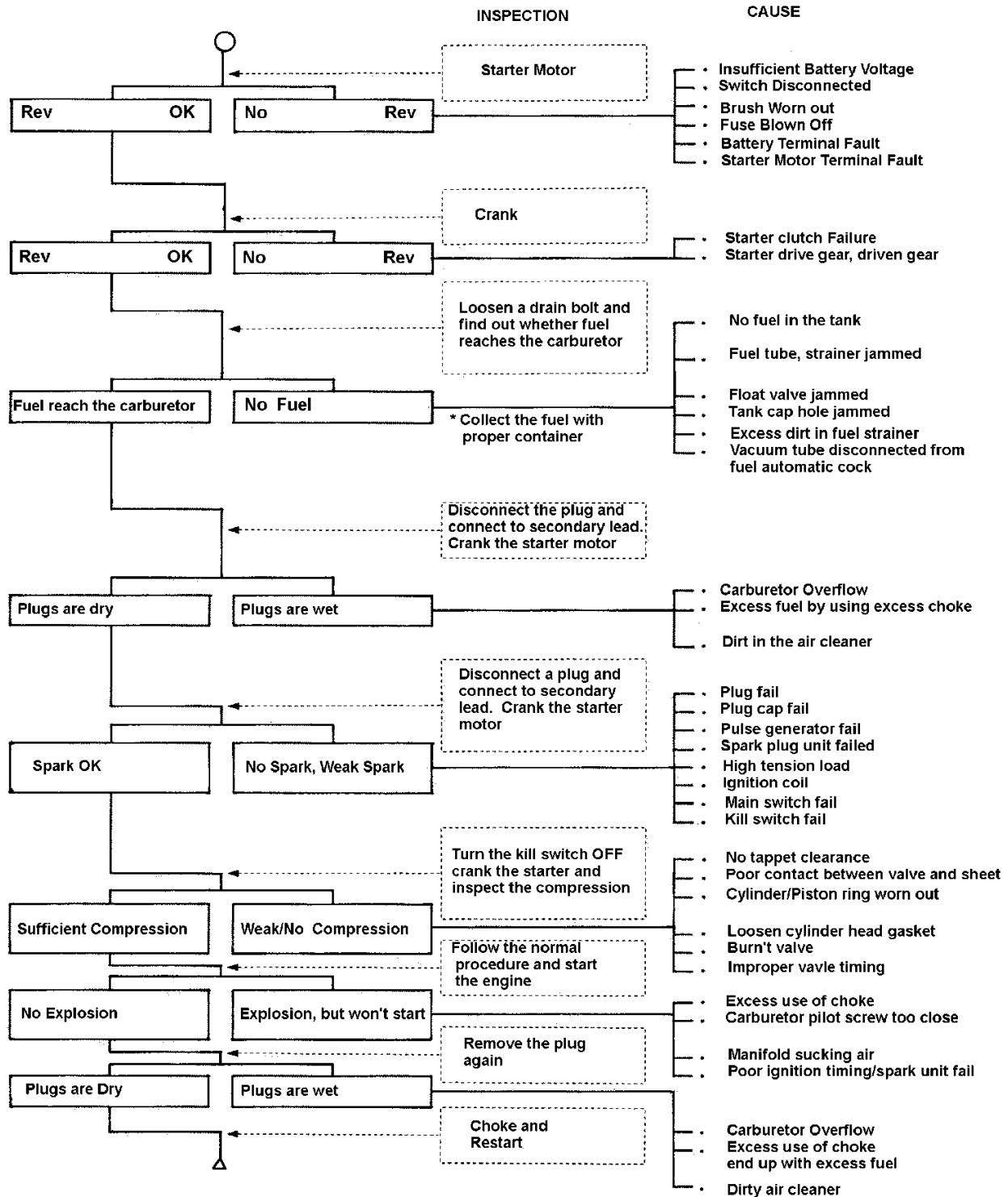

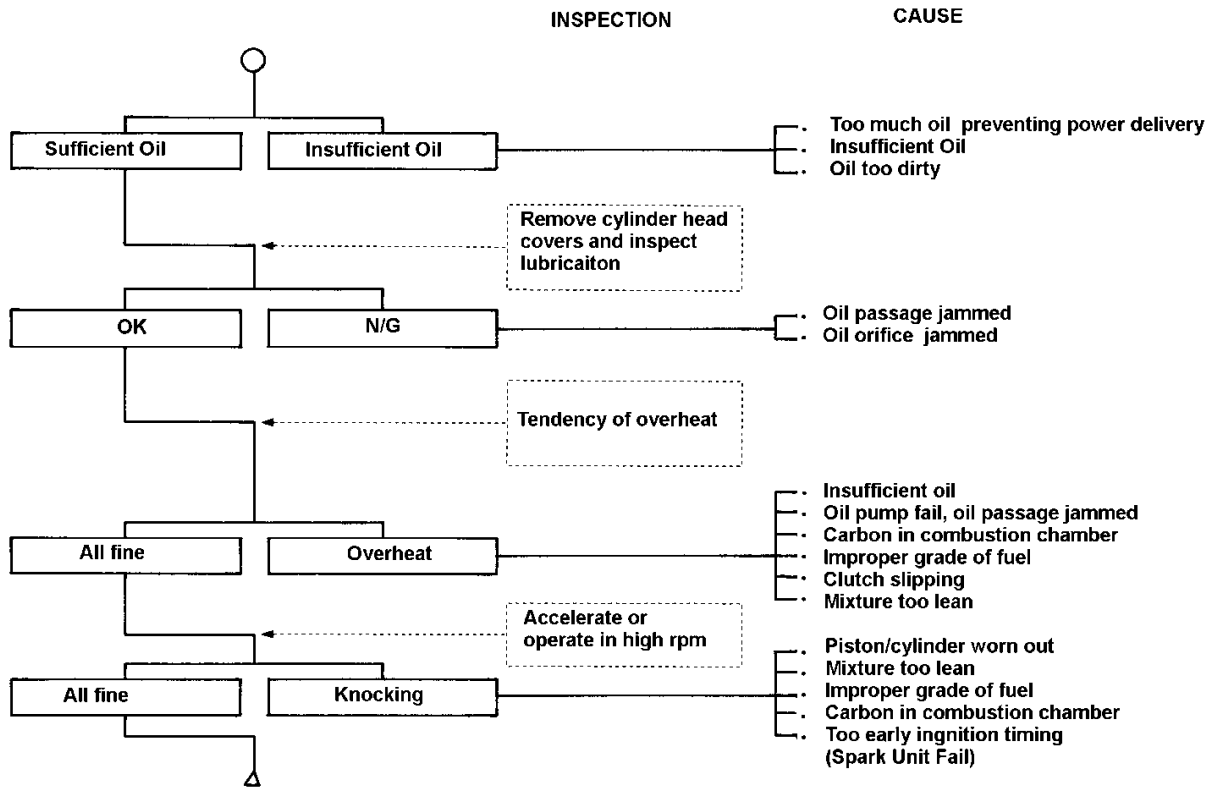

ROUGH RPM (MAINLY LOW AND IDLING RPM)

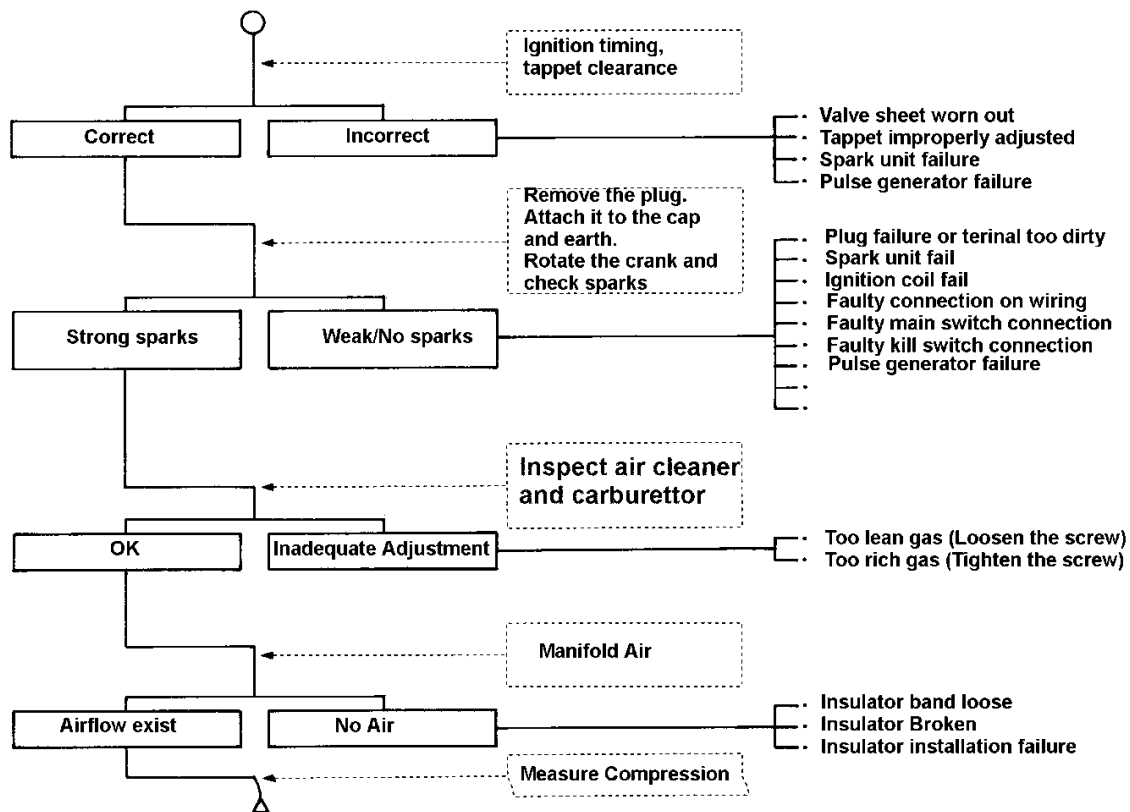



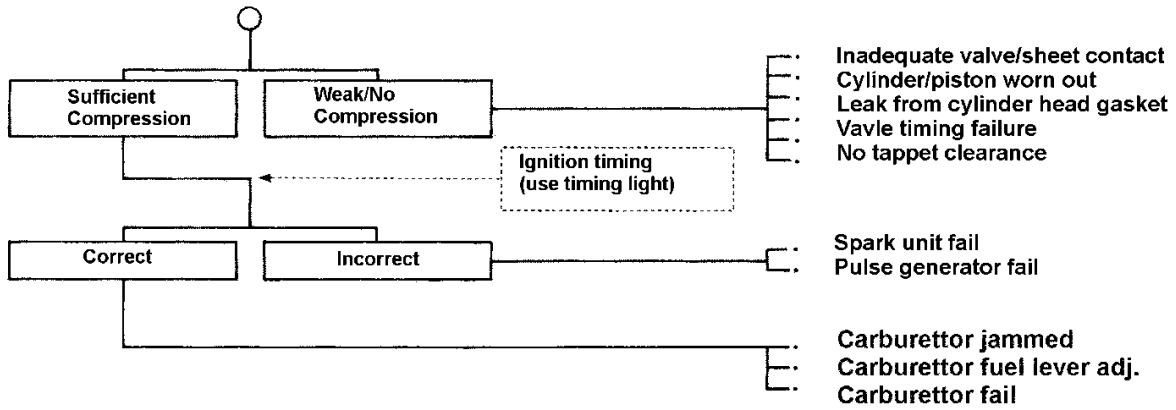

ROUGH RPM (HIGH RPM)

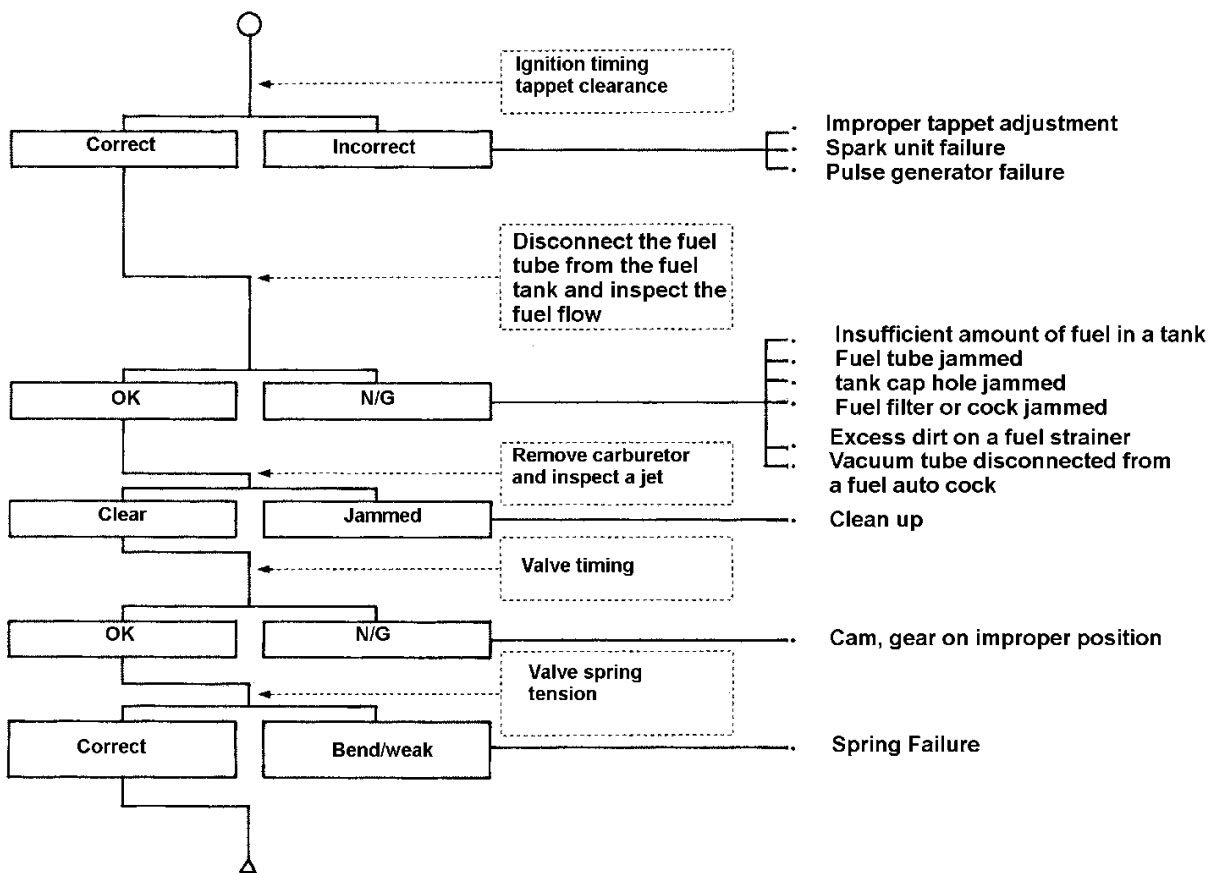

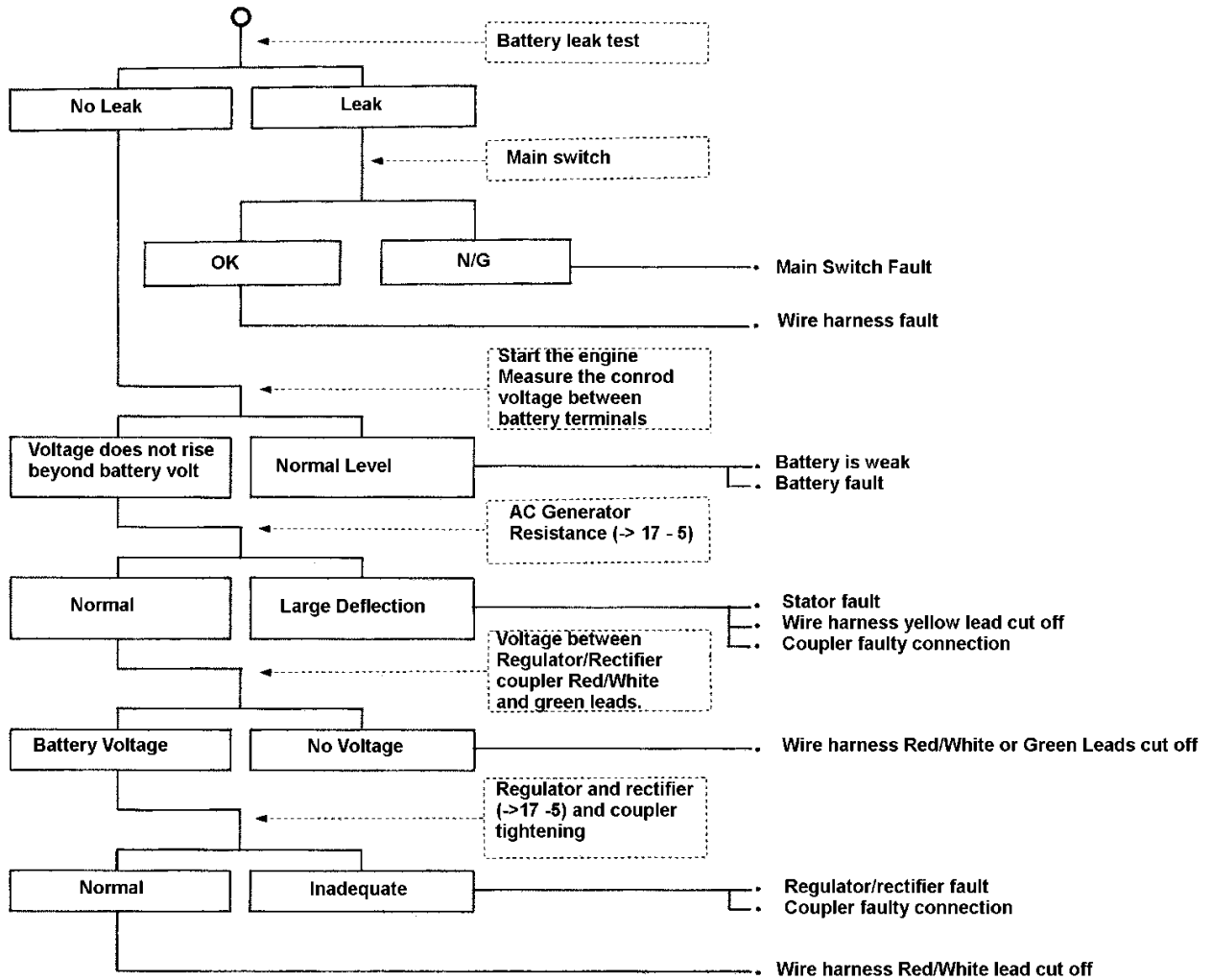

CHARGING PROBLEM (OVERCHARGE)

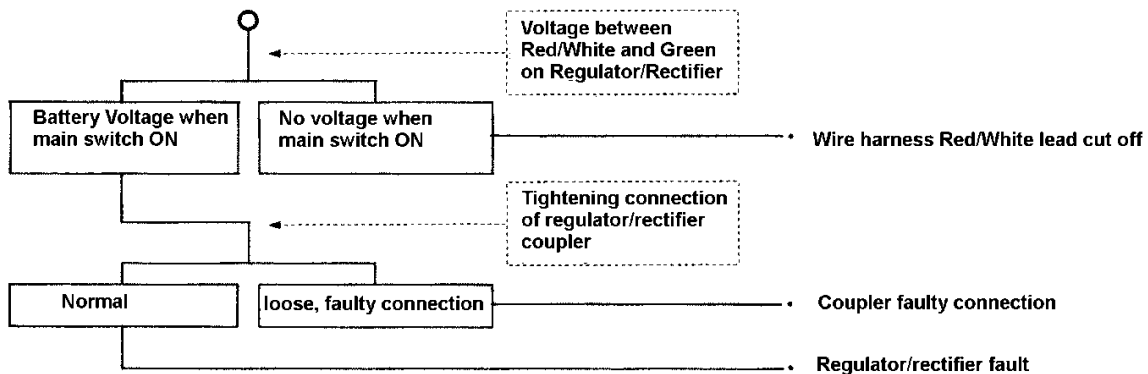

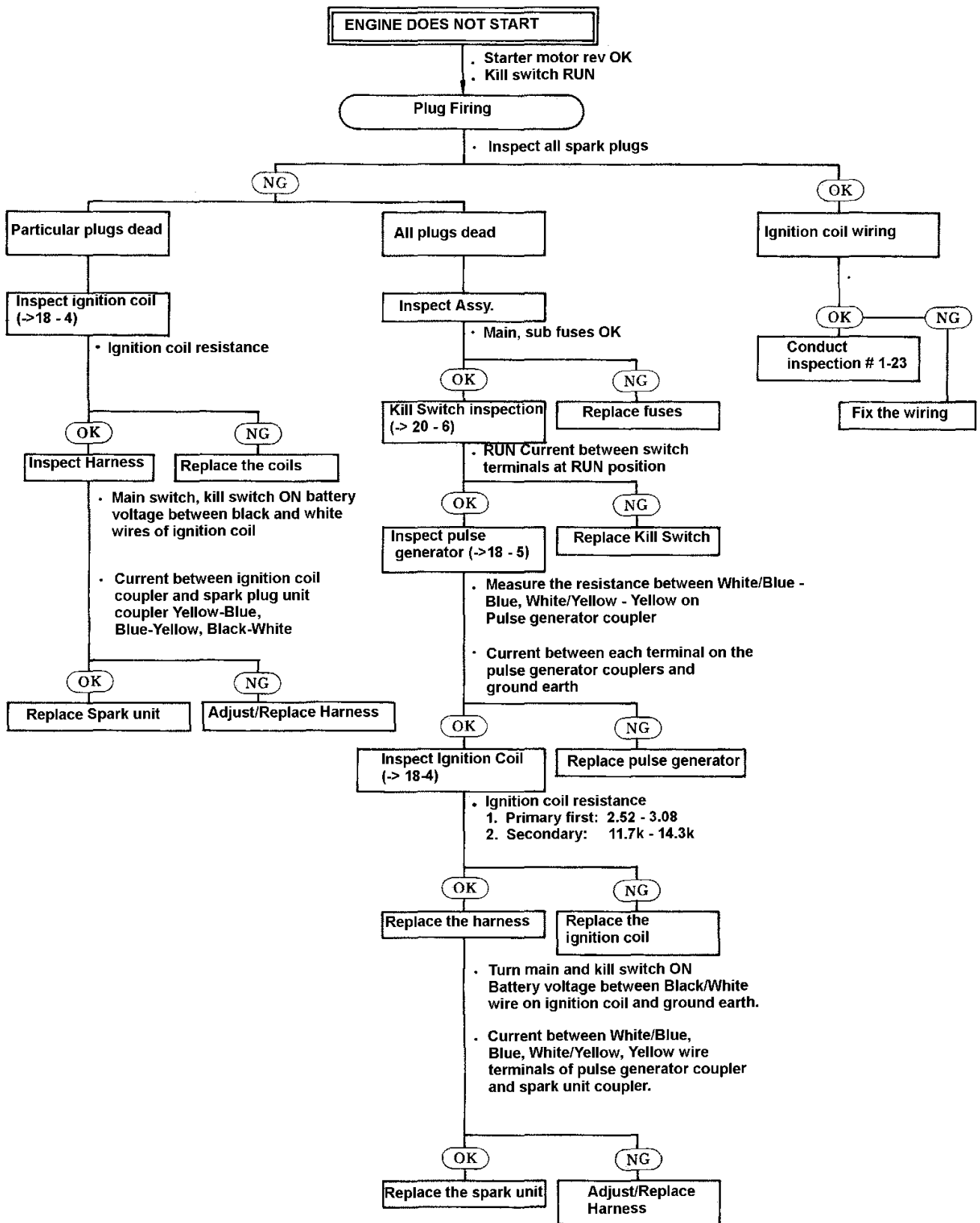

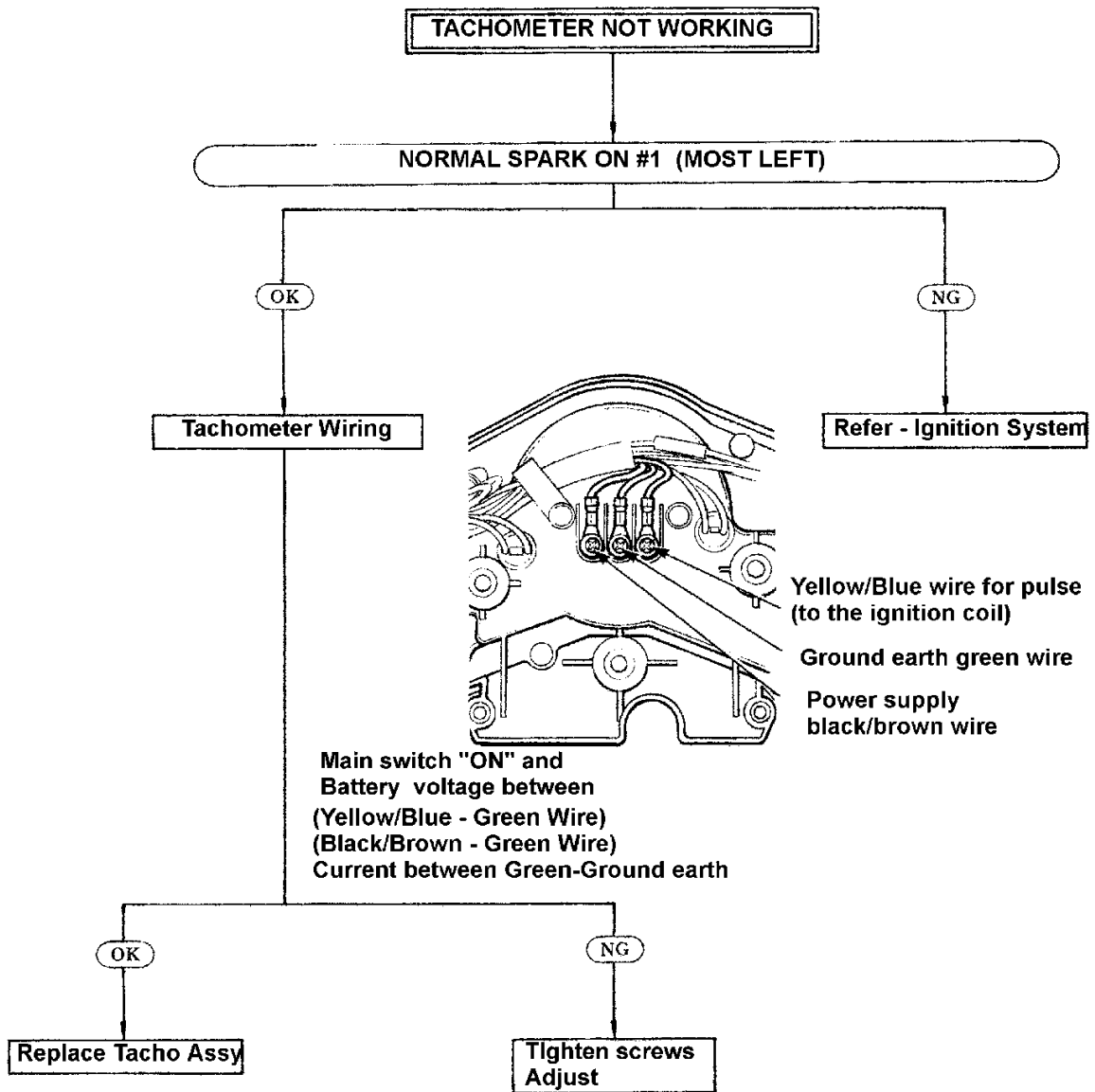

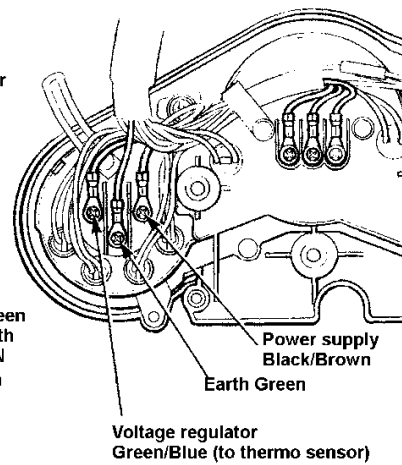
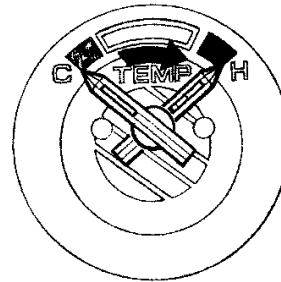
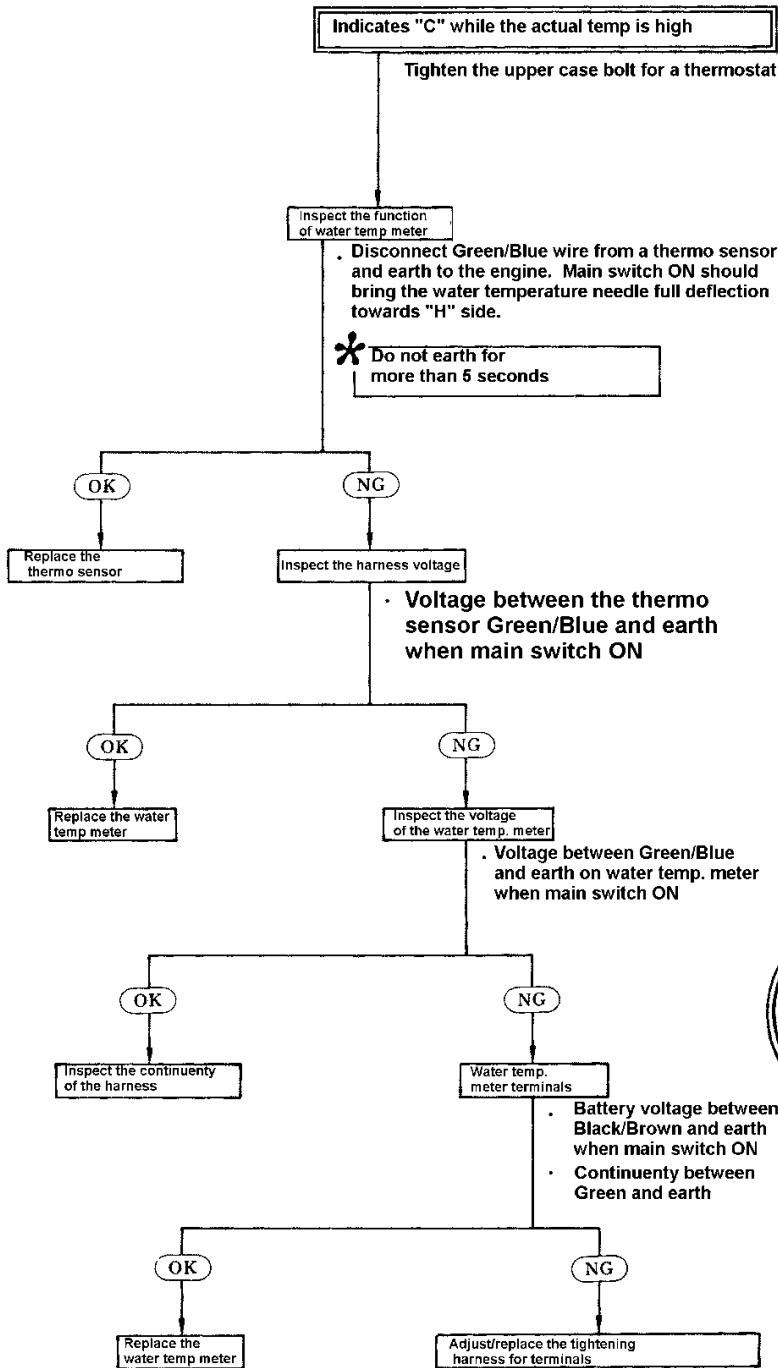

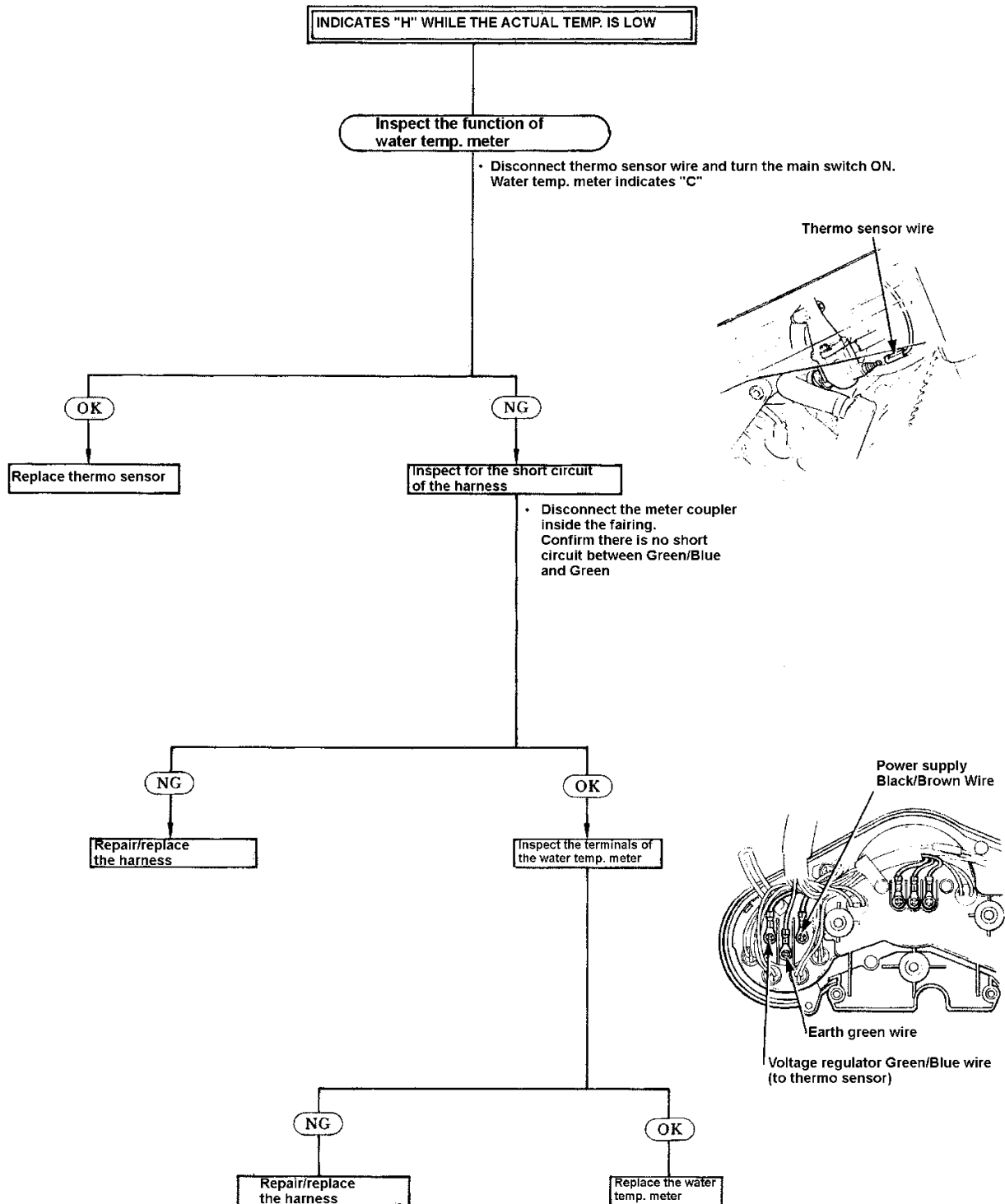

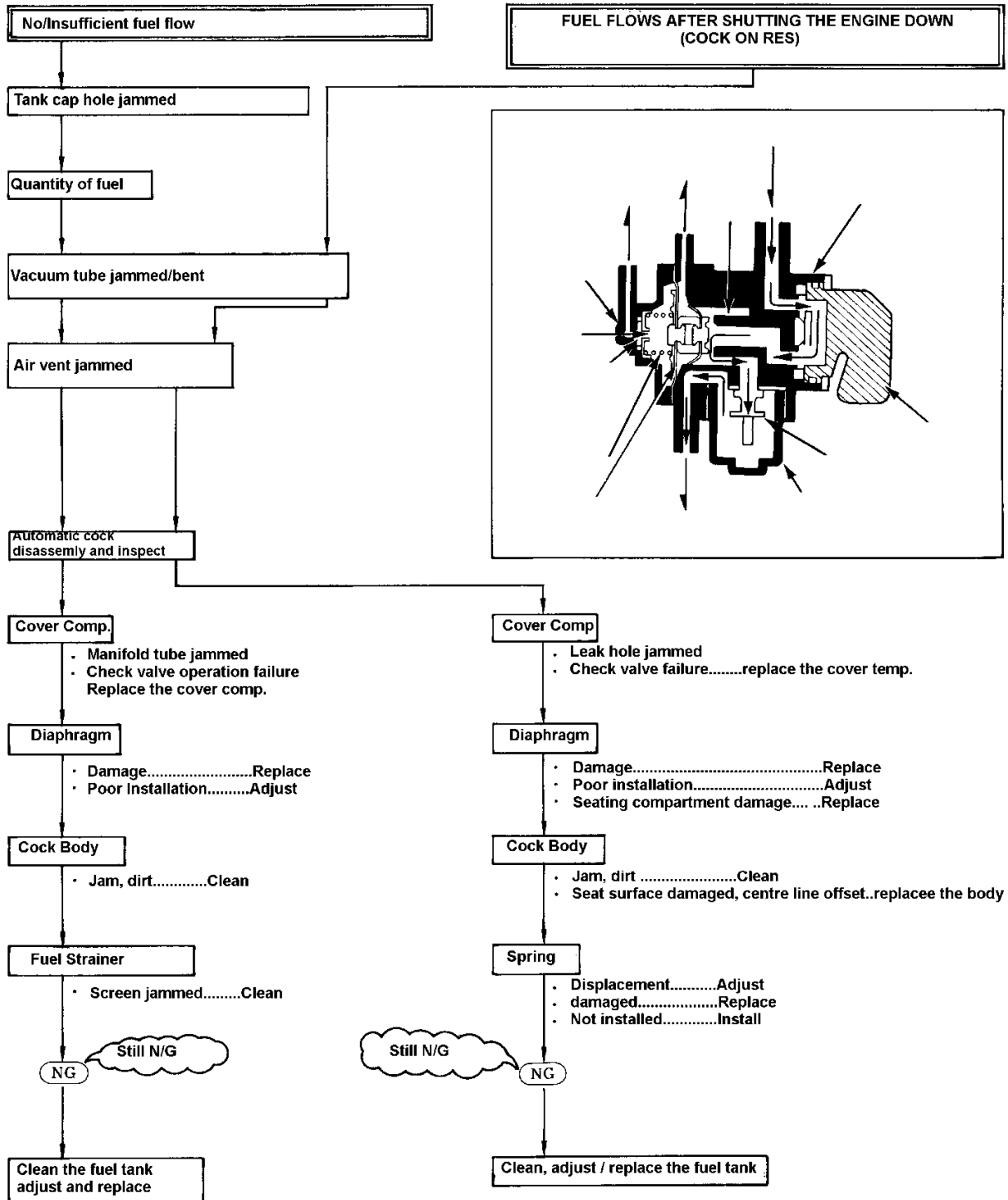

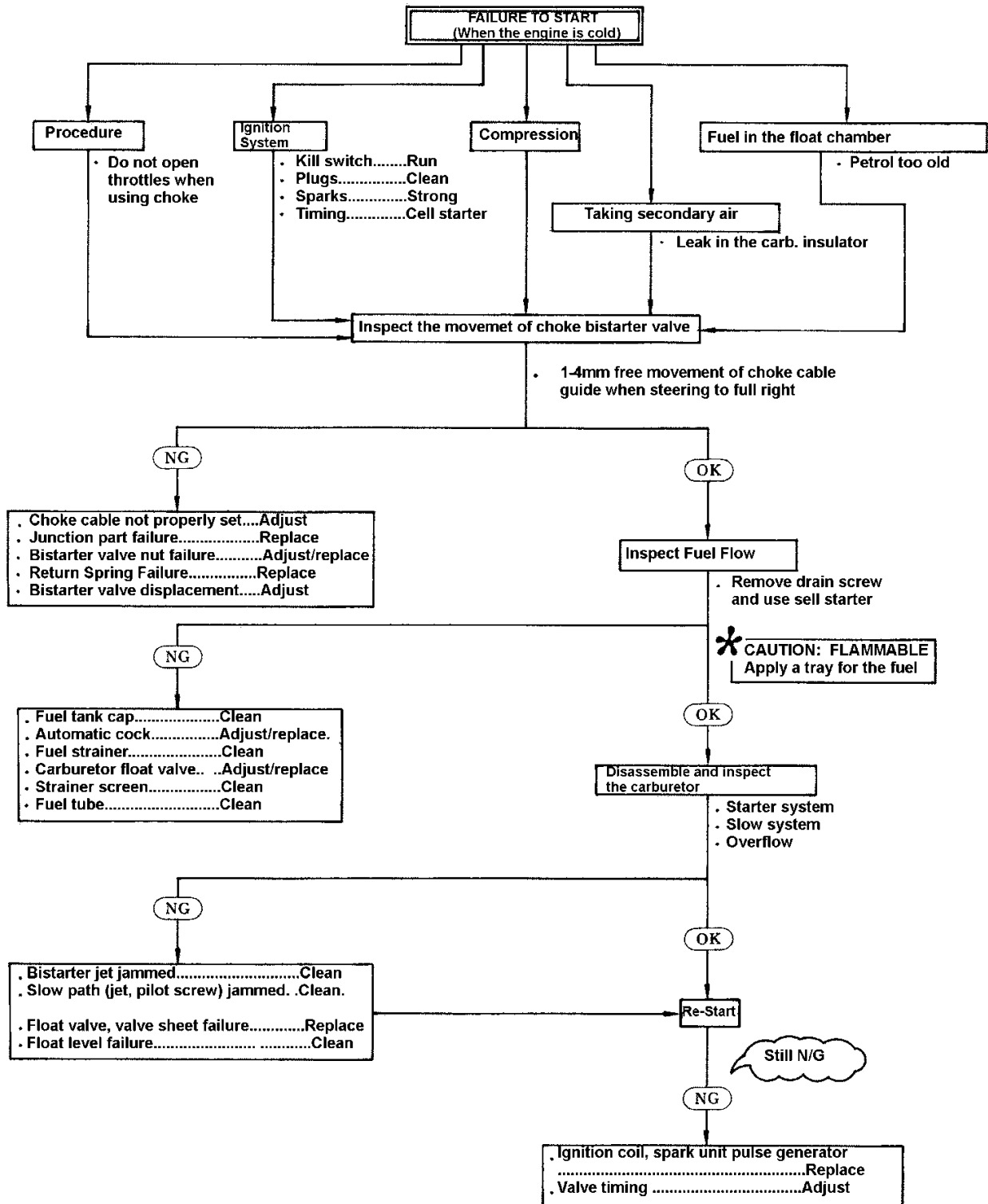



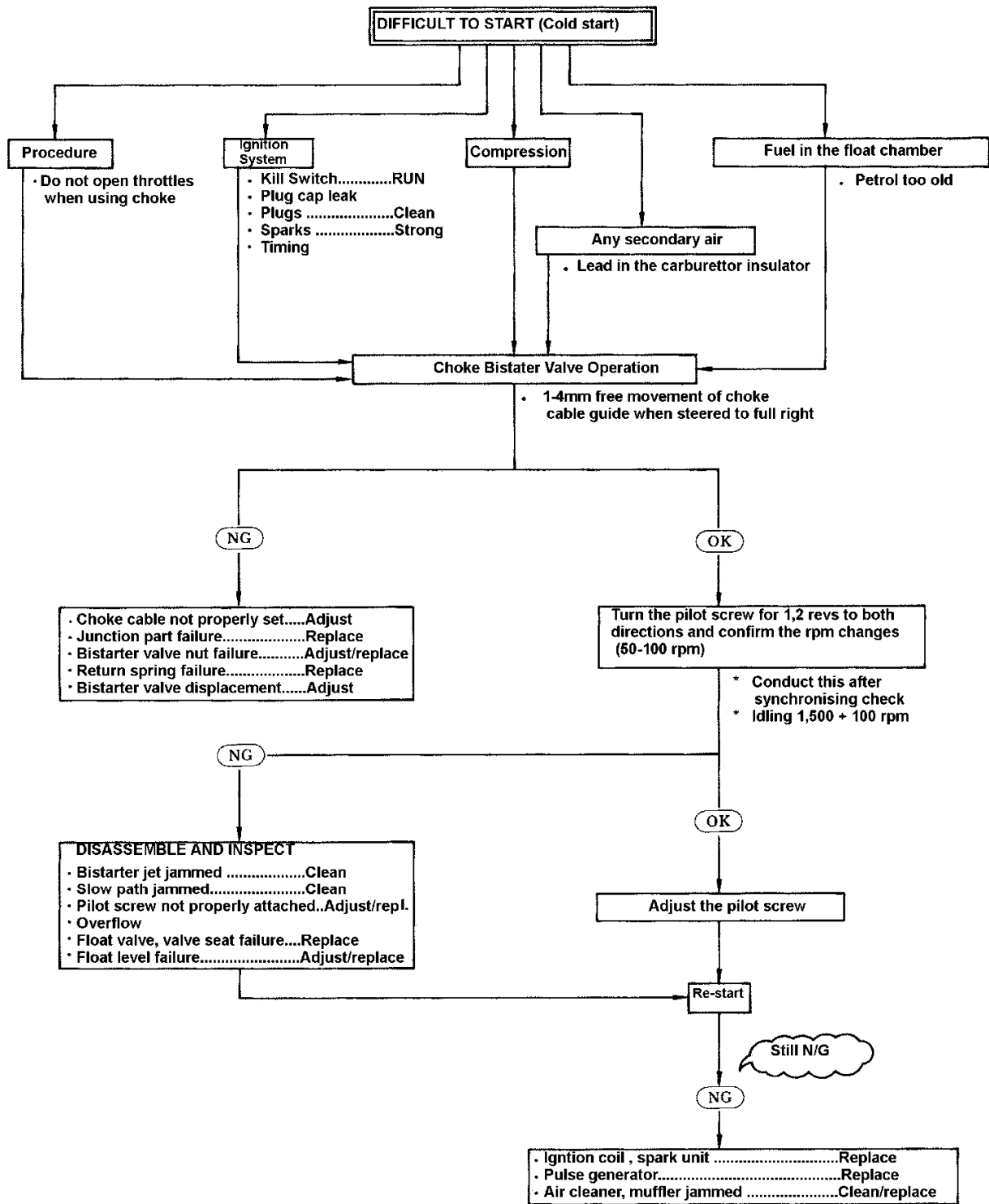

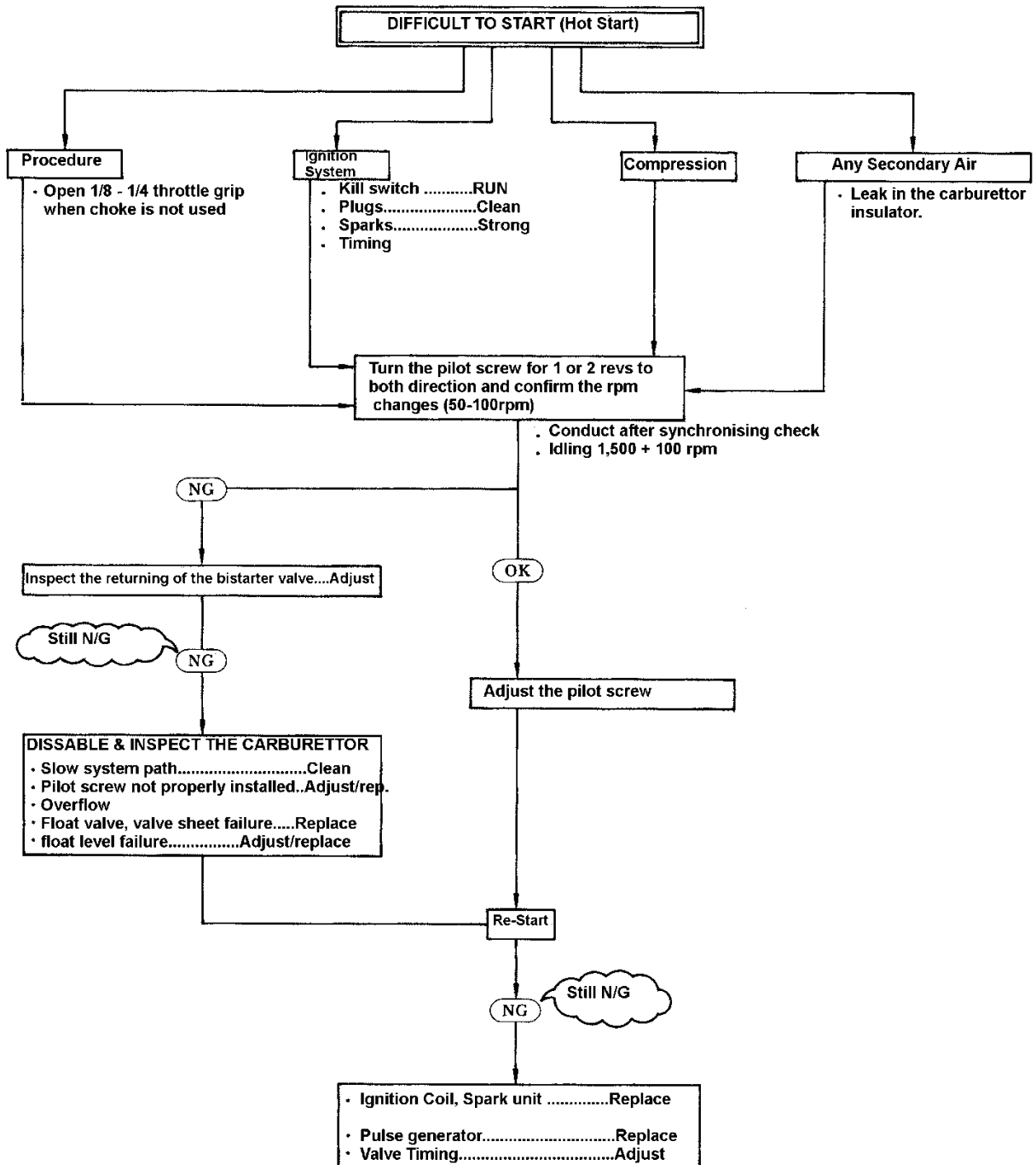

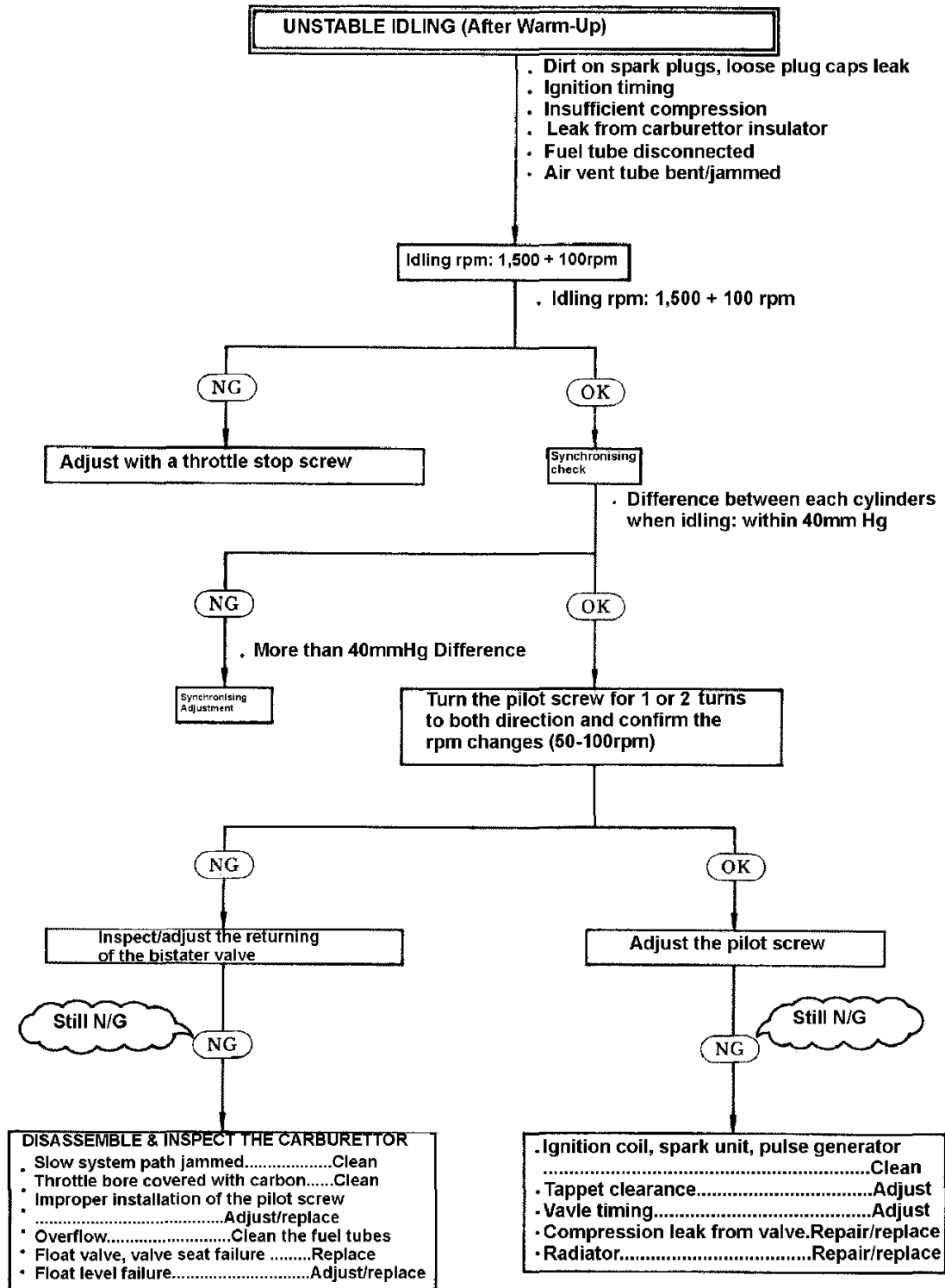

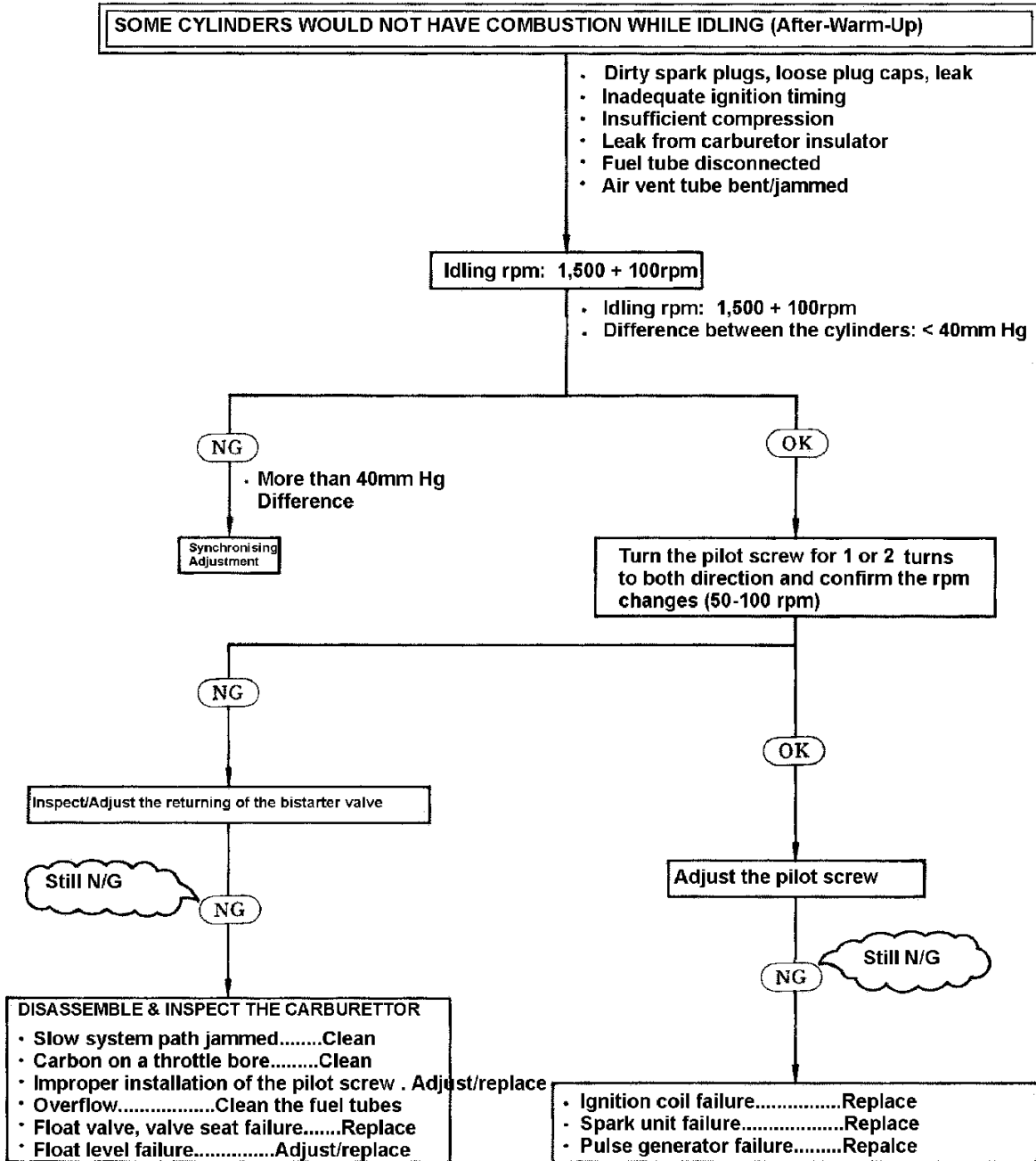

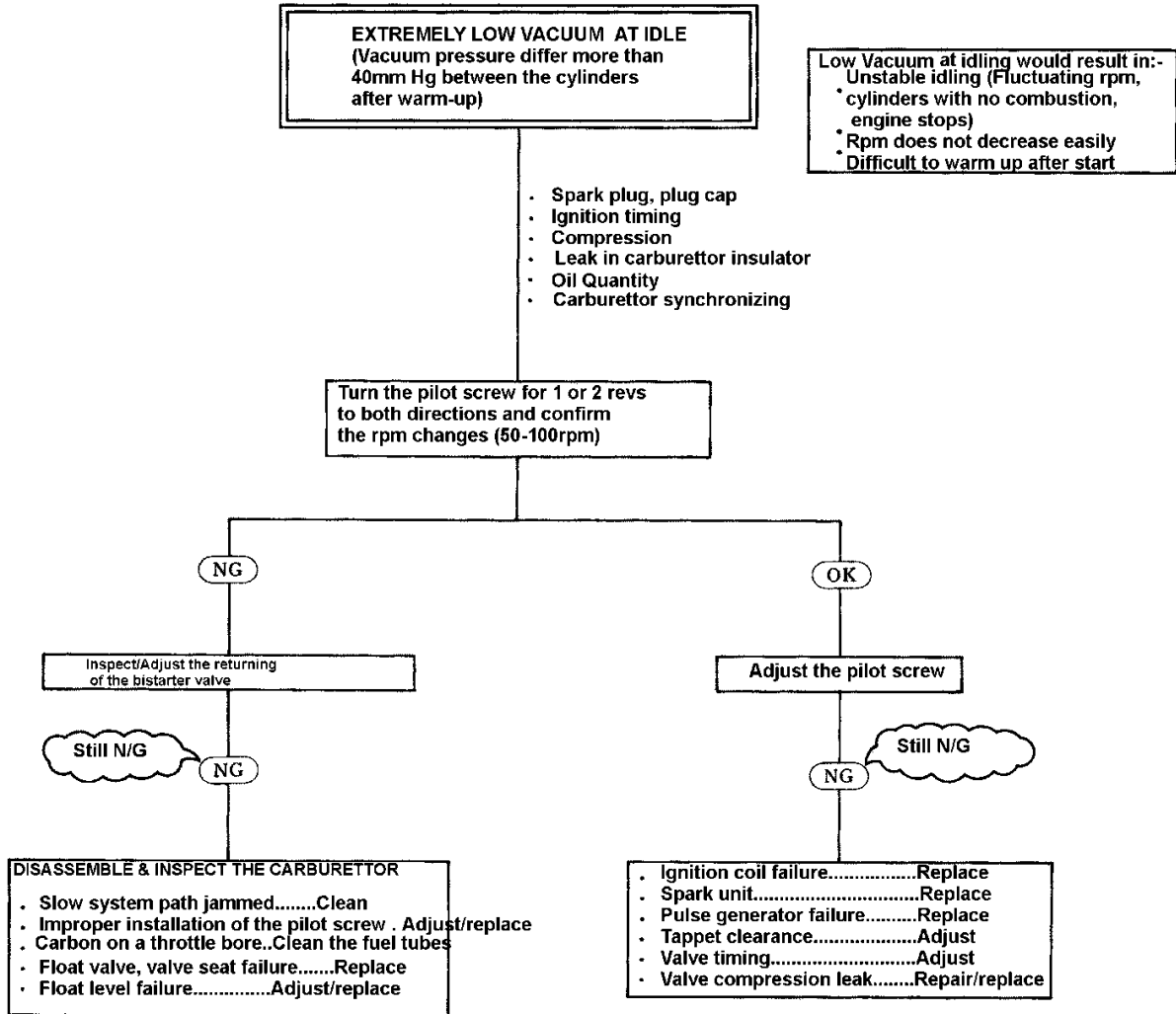

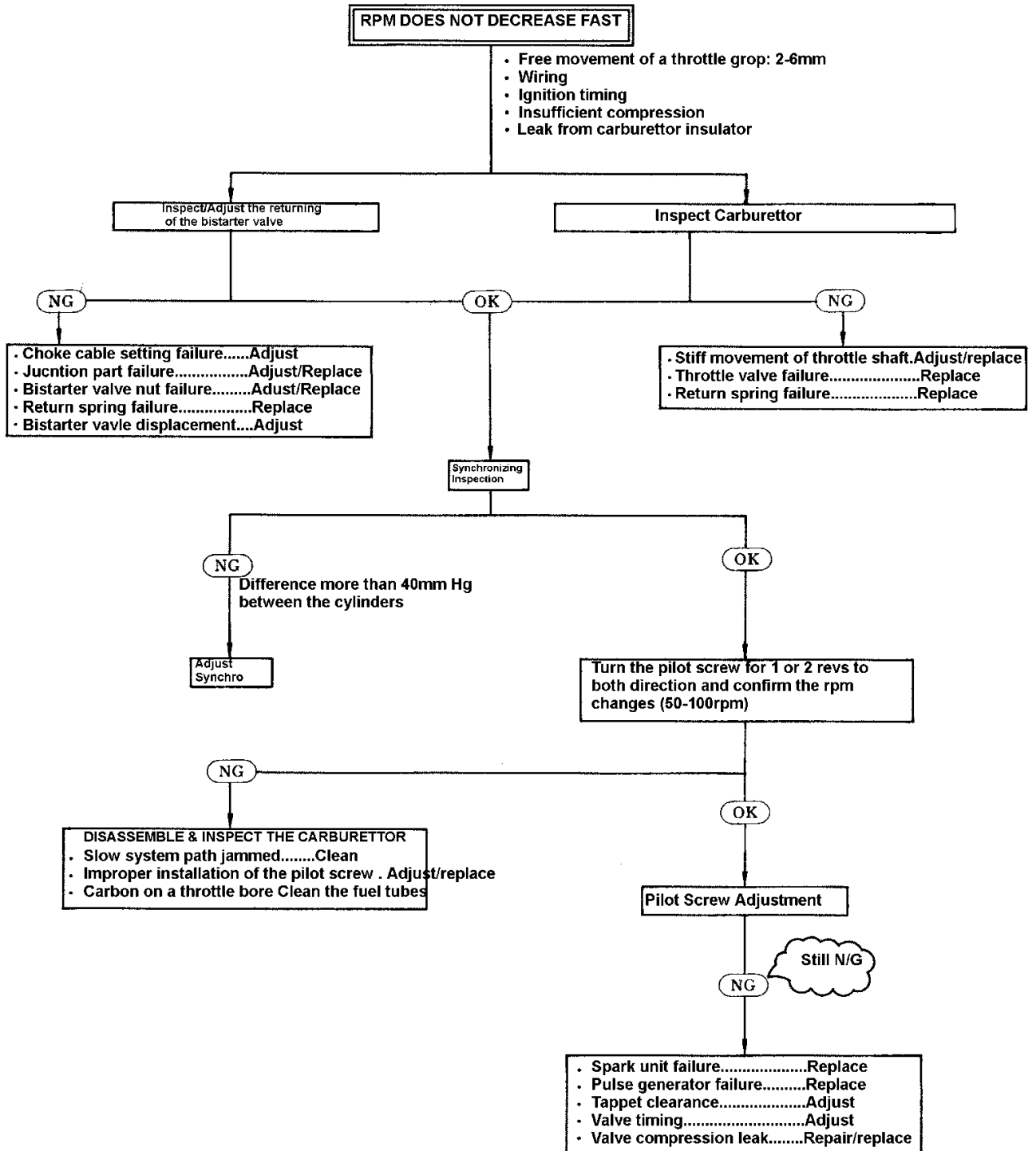

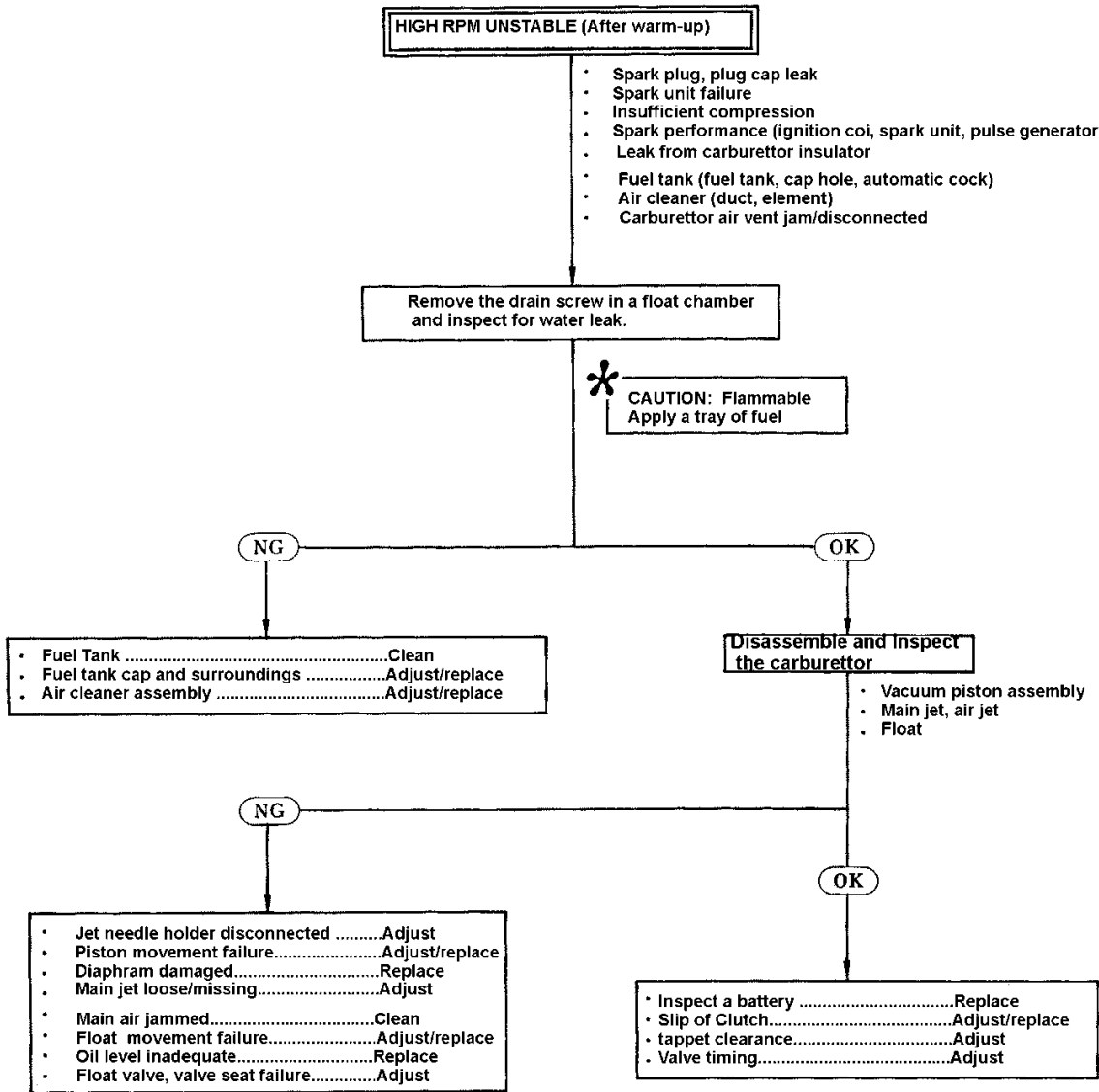

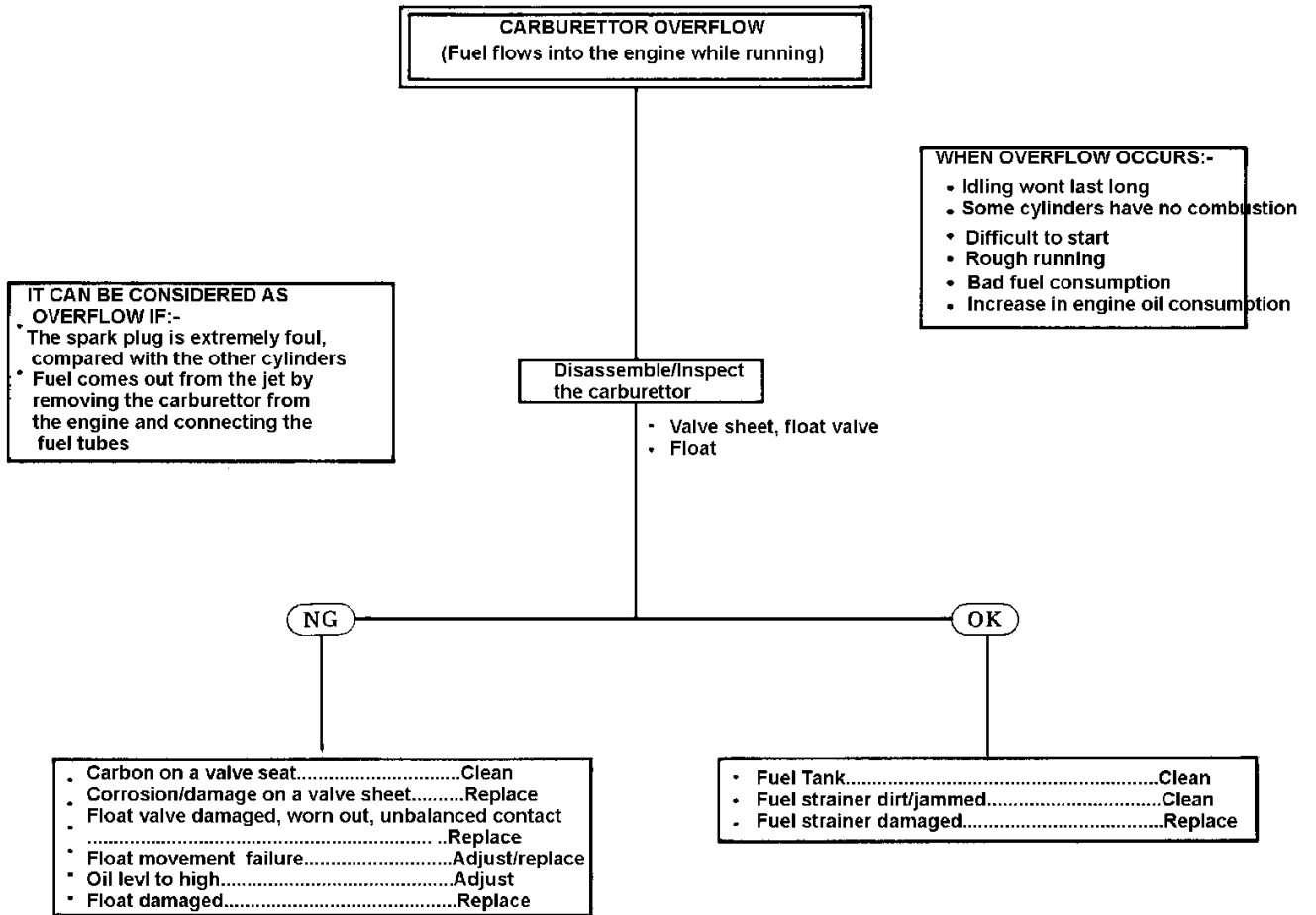



# CBR250R,RR

## 2. Inspection/Adjustment

Service schedule	2 – 1	Drive system	2 – 8
Steering system	2 – 4	Electrical system	2 – 10
Braking system	2 – 4	Powerplant	2 – 11
Driving system	2 – 6	Lubrication	2 – 16
Shock absorbing system	2 - 6	Others	2 - 19

### Service Schedule

- (Notes):
1. Service items include high speed operation items.
  2. (●) indicates mandatory inspection. (○) indicates the manufacturers recommendation.
  3. (★) indicates scheduled replacement of security parts. However, the schedule may be adjusted accordingly to the vehicle's operating environment.
  4. "High speed operation" is defined as the operation at or above 80kph.

Items			Schedule				Notes
			Regular	1 month or 1000km	Private		
					Every 6 months	Every 12	
Steering system	Handlebar	Free play and attachment				●	
		Smoothness				●	
	Wheel	Steering angle				●	
		Fork	Damage			●	●
	Fork spindle attachment				●	●	Steering stem
	Fork spindle bearing looseness					●	Steering stem
Brake System	Brake pedal	Clearance between the floor and fully depressed pedal and free play.			●	●	Free play: Front brake (lever) at lever end: 20-30mm Rear brake (pedal): 20-30mm
		Free play and movement	●				
		Braking performance		○	●	●	
	Rod & cables	Looseness, damage		○		●	
		Hose & pipe	Leak, damage, attachment		○	●	●
	Reservoir		Brake hose replacement				
		Quantity	●		●	●	Reservoir fluid level: Front: at or above minimum line Rear: between minimum and maximum
	Cylinders & calipers	Function, wear and damage				●	
		Master cylinder and wheel cylinder cups, dust seal and disc caliper rubber parts replacement					★ bi-annual
	Drum & shoe	Drum lining clearance			●	●	
		Shoe contact area and lining wear				●	Indicator
		Drum wear and damage				●	Standard: 140mm      Service limit: 141mm
	Pad & disc	Disc – pad clearance				●	
		Pad wear			○	●	Indicator
		Disc wear and damage				●	Standard thickness: 4.0mm Service limit: 3.5mm
Fluid	Brake fluid change						

Items		Schedule				Notes				
		Regular	1 month or 1000km	Private						
				Every 6 months	Every 12 months			Front	Rear	
Drive System	Wheel	Tyre pressure	●		●	●	(unit: kg/cm <sup>2</sup> )			
							One person	Normal	2.00	2.25
								High speed	2.00	2.25
							Two people	Normal	2.00	2.25
		Tyre specification		100/80	-17 52H	130/70	-17 52H			
		Tyre crack, damage	●		●	●				
		Tyre tread and unusual wear	●		●	●	Tread depth ≤ 0.8mm front, rear			
		Any debris on tyres	●		●	●				
		Wheel nuts and wheel bolts tightness			●	●	Axle nuts / holders: Front axle holder torque: 1.8-2.5kg-m Front axle torque: 5.5-6.5kg-m Rear axle nut torque: 8.0-10.0kg-m			
Rim, side ring, and wheel disc damage		○		●	Wheel rim runout at rim edge. Front: Axial 2.0mm or less Radial 2.0mm or less Rear: Axial 2.0mm or less Radial 2.0mm or less					
Front wheel bearing looseness				●						
Rear wheel bearing looseness				●						
Shock absorbing system	Chassis spring				●	Cushion spring				
	Suspension arm				●					
	Shock absorber	Oil leak and damage				●	Air – contained cushion			
		Attachment looseness				●	(unit: kg/cm <sup>2</sup> ) Air pressure Front 0 – 0.4			
Transmission	Clutch	Lever free play			●	●	Clutch lever free play: 10 – 20mm			
		Clutch function		○	●	●				
	Transmission	Leak and fluid level			●	●	Dipstick between min-max lines			
		Control looseness				●				
	& sprocket	Chain slack		○	●	●	Mid point between two sprockets, Sidestand is used 15-25mm			

	Sprocket installation / wear				•	
--	------------------------------	--	--	--	---	--

Items		Schedule				Notes	
		Regular	1 month or 1000km	Private			
				Every 6 months	Every 12 months		
Electrical system	Ignition			•	•	Plug gap: 0.8 – 0.9mm	
	Battery				•		
	Wiring				•		
Powerplant	Main component	Starting and noise			•	•	
		Low speed and acceleration		○	•	•	Idling rpm: 1,500 ± 100 rpm
		Exhaust			•	•	
		Air filter element replacement					Every 20,000km
		Valve clearance		○		•	Intake: 0.13 - 0.19mm) when Exhaust: 0.20 - 0.26mm) cooled
	Lubrication System	Oil contamination and level			•	•	Dipstick between min-max levels
		Oil leak			•	•	
		Oil quantity (level)	•				
		Oil change		○			Initial: 1,000km 6,000km after initial change
		Oil filter change					Initial: 1,000km 12,000km after initial change
	Fuel System	Fuel leak			•	•	
		Carburettor linkage system				•	
		Throttle valve / choke valve status				•	
		Fuel filter				•	
		Fuel level	•				
		Fuel hose change					Every four years
	Cooling System	Coolant level	•		•	•	Reservoir should be between min-max lines
		Coolant leak	•			•	
		Radiator cap function				•	0.75-1.05kg/cm <sup>2</sup> valve opening pressure
		Coolant change					Bi-annual

### Steering System

- Steering fork

Lift the front wheel. Check for smooth movement by turning the handle bars left and right.

Inspect the steering head bearing if resistance was found. Replace the bearing as required (13-26). Adjust the steering adjust nut (13-29). Confirm no obstruction on wires and cables.

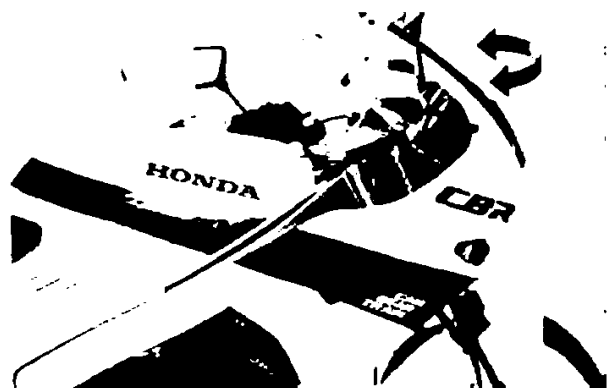

### Brake System

- Brake pedal.

[ Height adjustment ]

- Adjust the height by loosening a locking nut and rotating the stopper bolt.
- Tighten the locking nut.
- After the adjustment confirm the function of rear stoplight switch and adjust as required (2-19).

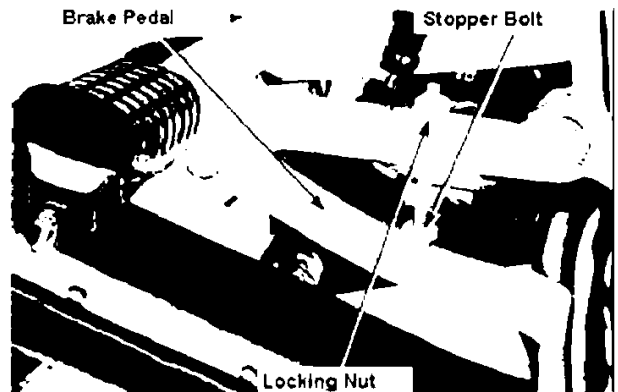

- Inspect the free movement of a brake pedal (20~30mm).

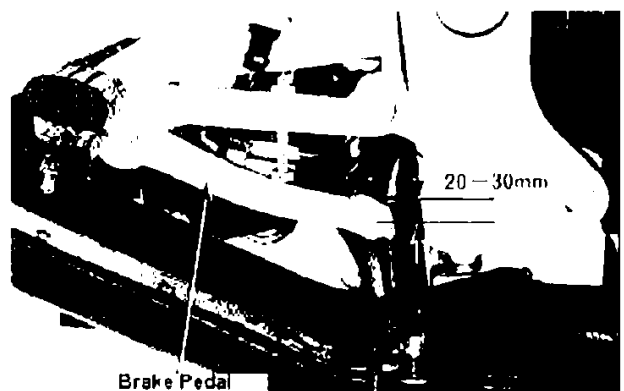

### Brake Lever

Operate the front brake lever and inspect its operation for air in the system.  
If air is suspected to exist, drain the air (15-3).

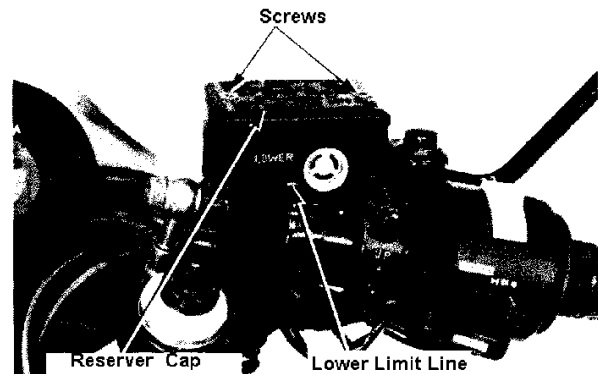

(Brake Fluid)

- Check the quantity of the brake fluid. If the fluid level is low, inspect for any leaks. Remove the two screws on the reservoir cap and refill with DOT3 or DOT 4 standard brake fluid till the upper limit is reached.

- Do not mix different suppliers' fluids to avoid chemical reaction.
- Make sure no water or debris go in when refilling.
- The fluid may damage the paint, plastic and rubber surface.

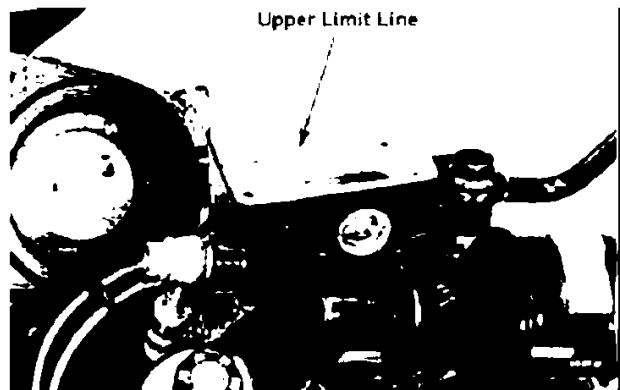

### Brake disk/pad.

Hold the brake lever to its limit and inspect inner/outer brake pads. Inspect the wear from the direction shown in the figure. If they were worn out to the limit mark, replace them (15-4).

Replace pads in a set.

Inspect the brake disk contact surface for abnormal wear or damage.

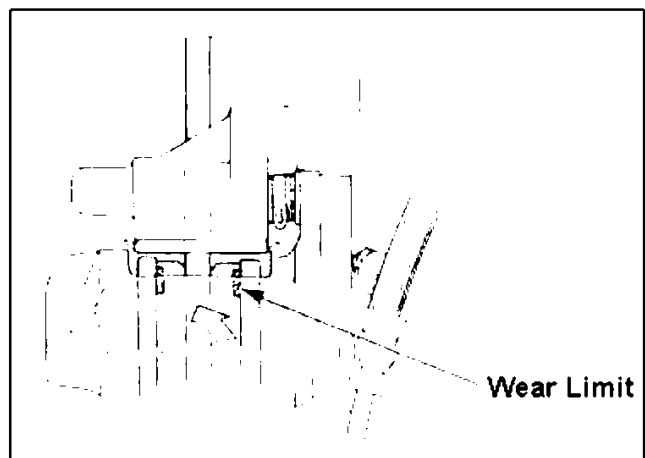

**Wheels**

- Measure the tyre air pressure.

Measure when the tyres are cold.

Tyre air pressure:

		Front kpa	Rear kpa
	Normal	2.00	2.25
One person	High speed	2.00	2.25
Two people	Normal	2.00	2.50
Tyre specification		100/80-1752H	130/70-1762H

- Wheel nuts and wheel bolts.

Inspect the tightness of wheel axial nut, axial holder nut on the front wheel and rear axial nut. Tighten as required.

Tightening torques:

- Front axial: 5.5 ~ 6.5 kg.m
- Axial holder nut: 1.8 ~ 2.5 kg.m
- Rear axial nut: 8.0 ~ 10.0 kg.m

- Rim and wheel disk damage

Inspect corrosion of front/rear rims /misalignment of wheels (13-10,14-3)

**Dampers**

- Oil leak, damage apply a front brake and compress the front cushion for several times and check it's operation.

Inspect the front fork for oil leak, damage and loose parts.

Compress the rear cushion for several times and check its movement.

Inspect the rear cushion for oil leak, damage and loose parts.

Lift the rear wheel, push the wheel to left and right, inspect the rattling of rear fork pivot bearing. Inspect the bearing if there is any rattling and replace it as required.

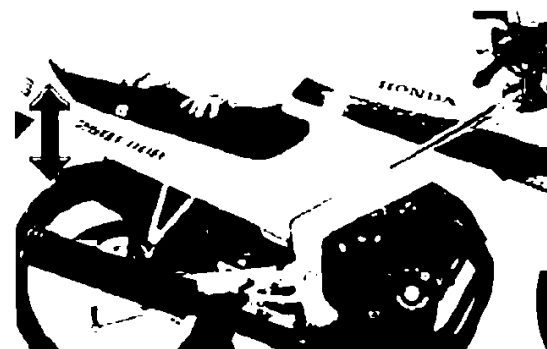
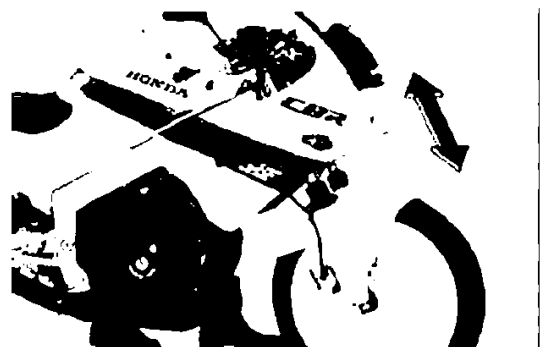
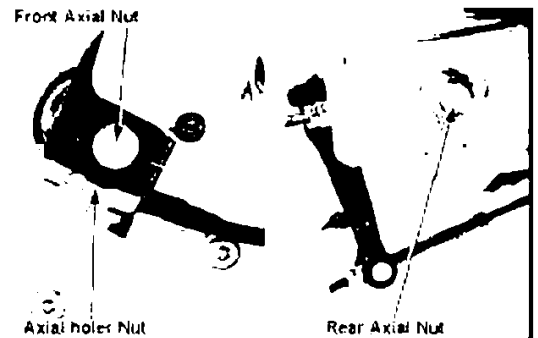

### Front fork air pressure.

Support the frame and lift the front wheel.  
Remove the valve cap.  
Measure the air pressure with an air pressure gauge.

### Max Air pressure : 0.4 kpa

In order to adjust the air pressure, increase the pressure by manual pump and gradually drain the air and adjust to the same pressure on both sides.

- When adjusting the air pressure, increase the pressure gradually.

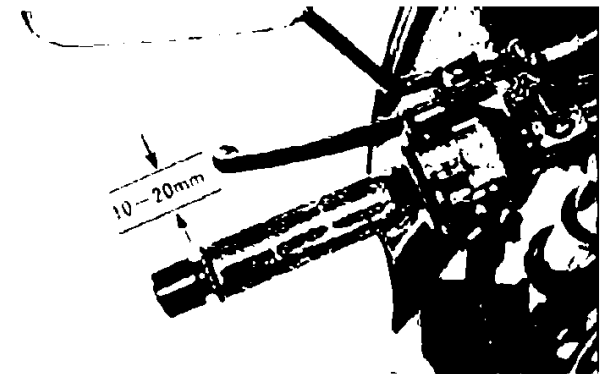
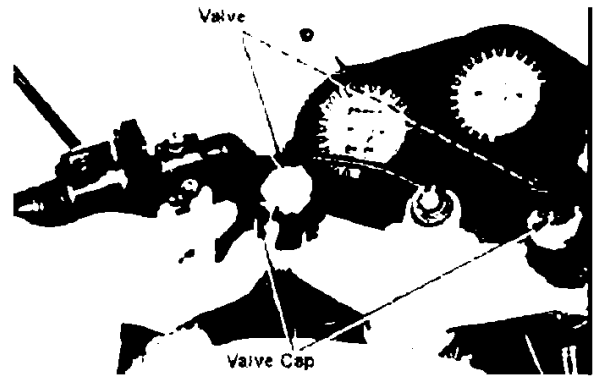

### Transmission

#### Clutch.

Inspect the free movement of clutch lever.  
10 ~ 20 mm.

Major adjustment can be done by loosening the locking nut and rotating the adjusting nut.

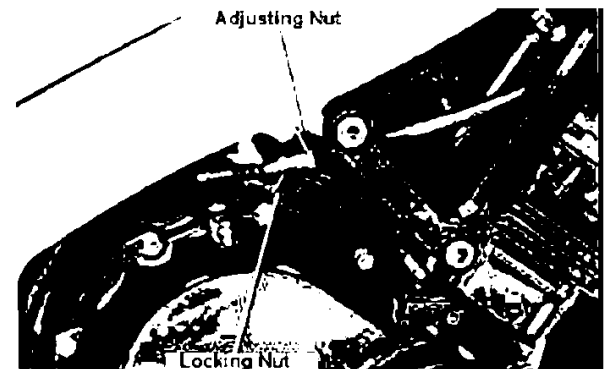

Precise adjustment can be done by loosening the locking nut on the handle side and rotating the adjuster.

Do not expose the threaded part of the adjuster for more than 8mm.

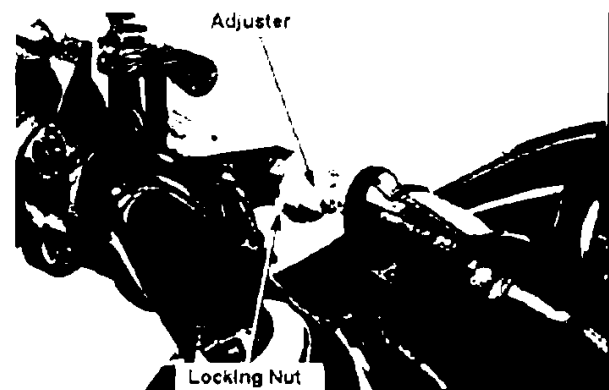

### Chain and Sprocket

Never inspect/adjust the drive chain while the engine is running.

Replace the chain, chain roller and pin as required.

- Loose drive chain.

Set the gear to neutral and apply a side stand. Inspect the tension of the chain at the mid point from sprockets on the lower side.

Max. amplitude : 15~25mm (with side stand)

- Adjustment
1. Loosen the axial nut.
  2. Loosen the locking nut and rotate the adjusting nut.

- Always align the arrow in a chain adjuster to the scales on both sides.
- If the arrow of a chain adjuster behind the axial shaft is aligned with the red zone of the rear fork, replace the drive chain.

Tighten the axial nut. Torque : 8.0~10.0 kgm. Tighten the adjusting nut and a locking nut. Apply SAE#90 oil on drive chain.

- Do not use steam washer, high pressure vehicle washer, or washing oil as they damage O-rings.
- Do not use chain spray contains thinner to avoid damaging O-rings.

- Installation and wear of sprockets. Inspect and replace the drive, driven sprockets as required.

Replace drive chain and both sprockets at a same time.

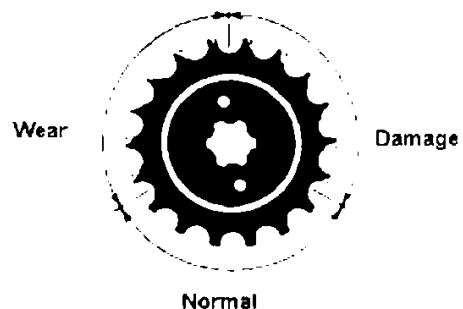
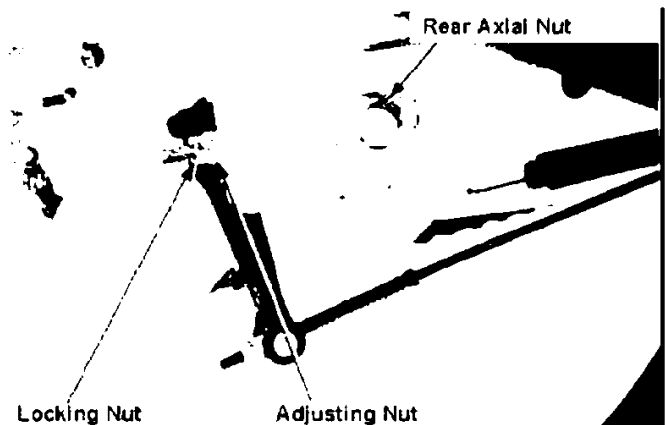
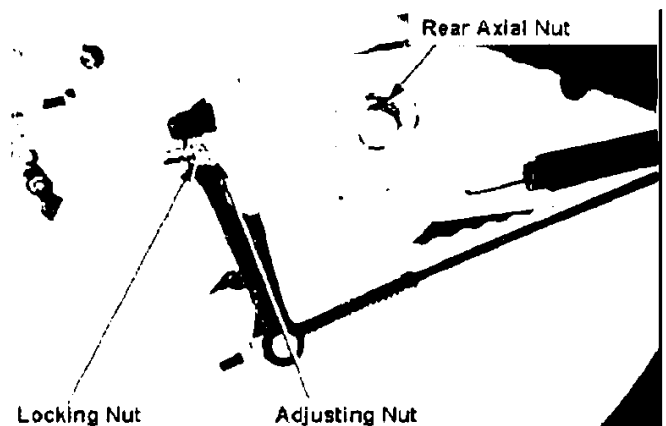
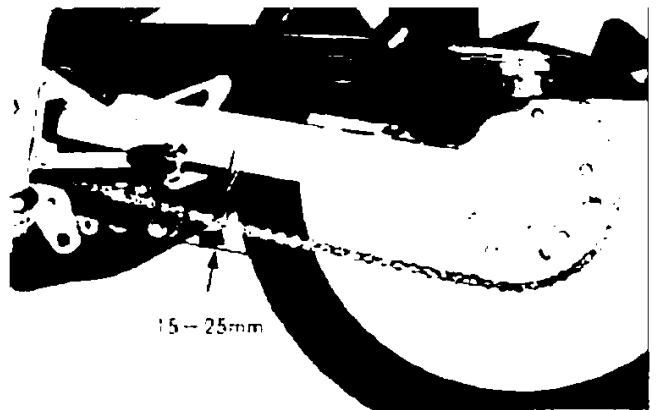



- Wear of chain slider.

Inspect/replace the chain slider.

The contact of the chain and the rear fork may cause damage/wear out of rear fork and chain. Replace frequently.

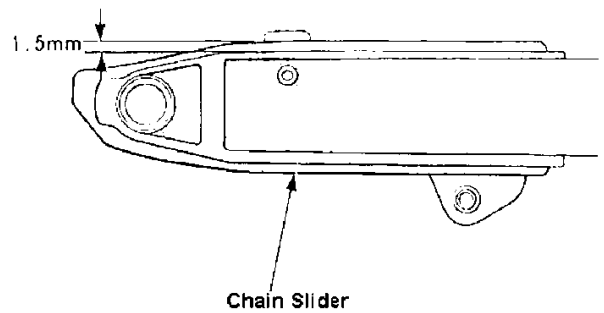

Inspect wear/damage of the chain slider.  
Replace if it is less than 1.5mm.

### Electrical System

Ignition system.

Remove a radiator set pin and swing the radiator to the front.

It can easily be detached by pushing down the set pin head and the pulling the pin out.

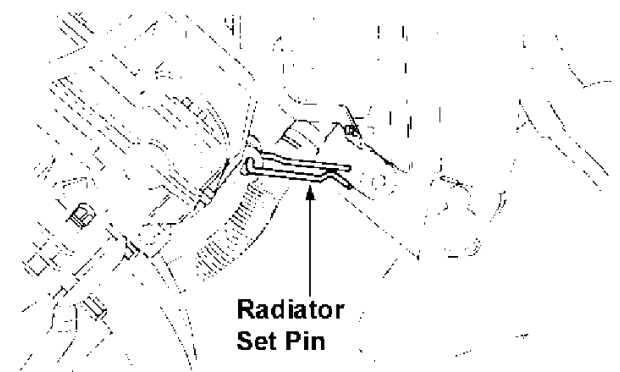

By using the pin, fix the radiator on an opened position.

Remove plug caps.

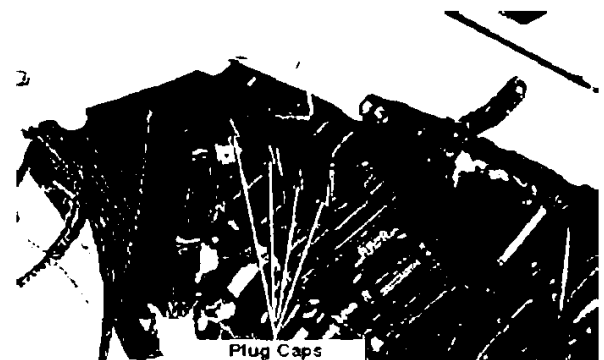

### Spark plugs.

Remove the plugs.  
Inspect for damage, dirt on the plugs.  
Clean the dirt with a plug cleaner or a wire brush.

Nominated plugs: NGK:C8EH-9  
C9EH-9  
ND:U24FE9  
U27FE9

Set the plug clearance 0.8~0.9mm.  
When tightening the plugs tighten with your fingers  
and then apply torque by using a plug wrench.

Torque: 1.0~1.2kg/m

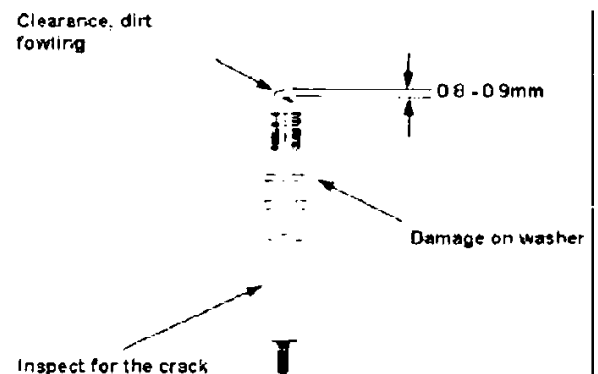

Ignition timing and adjustment is not required as we use transistor ignition system. If the ignition timing is inadequate, inspect/replace the spark unit, pulse generator.

Warm up the engine.  
Remove timing hold cap.  
Connect the timing light lead to the high tension lead for #1 cylinder.

"F" should align on the mark at idling ( $1500 \pm 100$  rpm). "F" moves towards left as engine rpm increases.

Apply oil on O-ring for a timing hole cap.

### Battery

- Terminal connection
- Remove a seat.  
Confirm the battery is fixed with battery holder band.  
Make sure the + and - cables are properly connected to the terminals.

### Powerplant

- Idling and acceleration.

- Adjust idling rpm after warming up.
- When carburettor is overhauled, idling adjustment should be done after the pilot screw adjustment (4-18).

Set the neutral gear. By rotating the throttle stop screw, adjust the - Idling rpm ( $1500 \pm 100$  rpm). If idling rpm is unstable or snaps, adjust the pilot screw (4-18).

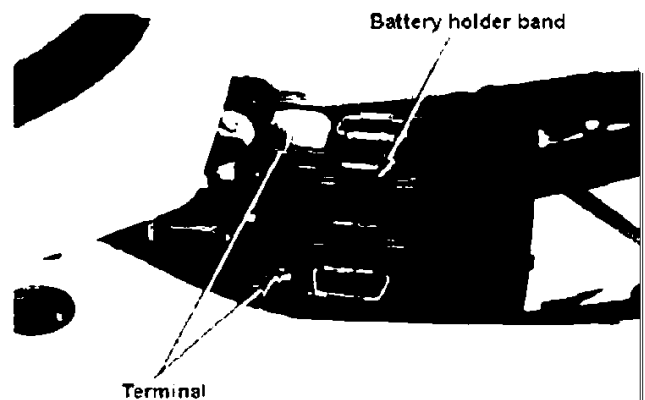
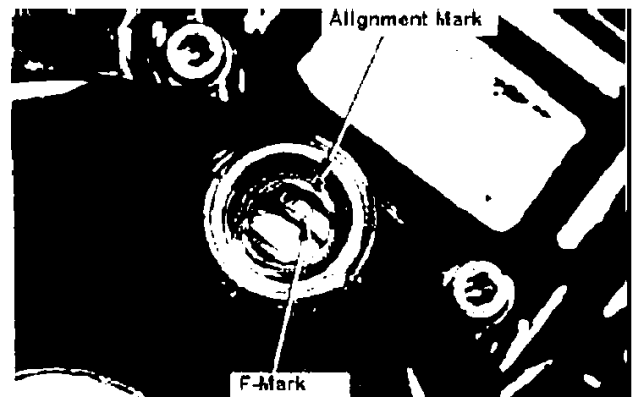
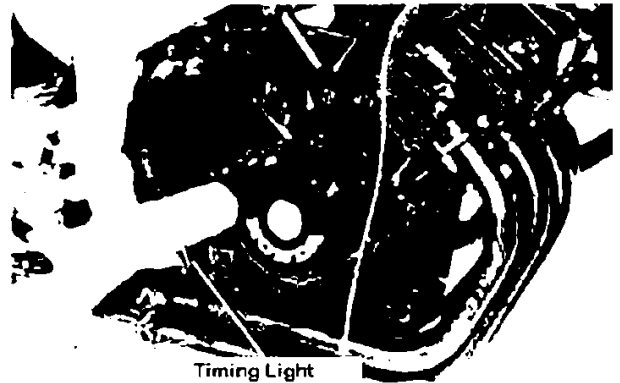

(Replacement of an air cleaner).  
Remove the fuel tank. (4-3).  
Remove a bolt, then a duct.

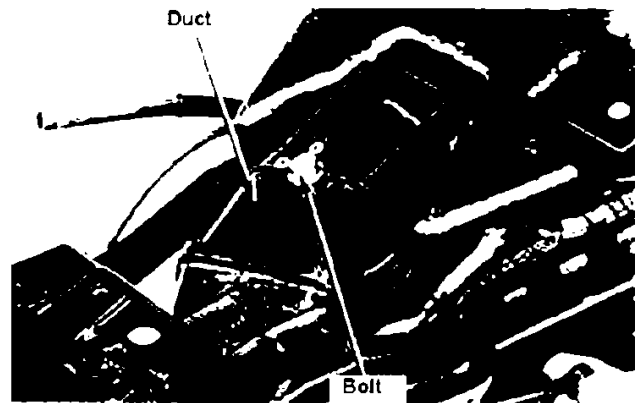

Inspect the element for dirt and damage.  
If there are severe dirt/damages, replace with the new unit.  
Recommended part change: every 20,000km.

- The filter paper in the element contains oil. (viscous type). Do not wipe or clean.
- If the vehicle is to be used in dusty conditions replace earlier than the period recommended.

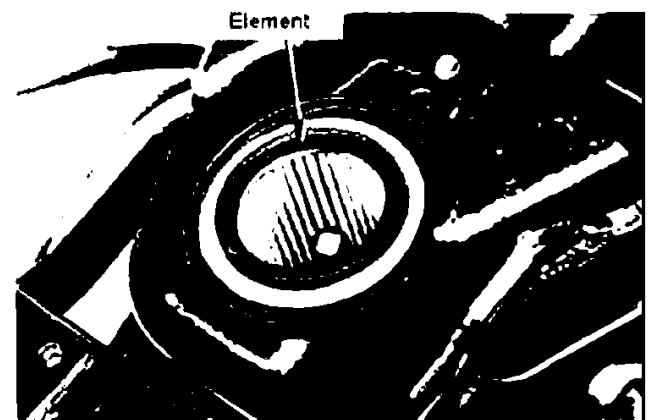

Reverse the above procedure for installation.

(Cleaning the sub air cleaner).  
Remove the fuel tank. (4-3).  
Remove the sub air cleaner cap.



If the filter is jammed or dirty, clean by using washing oil and dry.  
Attach the filter and tighten the bis.

Tightening torque : 0.5~0.8 kgm.

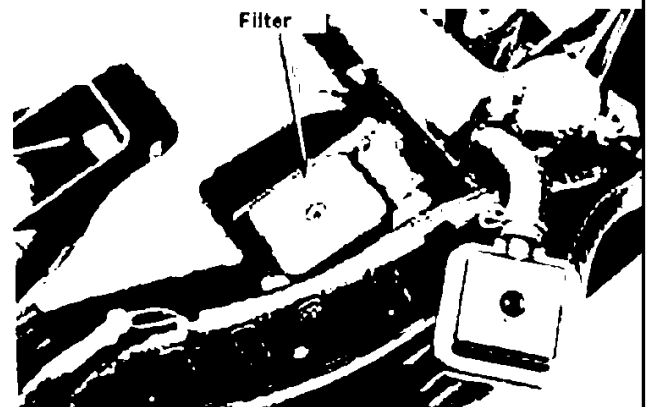

### (Air cleaner drain tube)

Inspect the air cleaner drain tube for any damages.

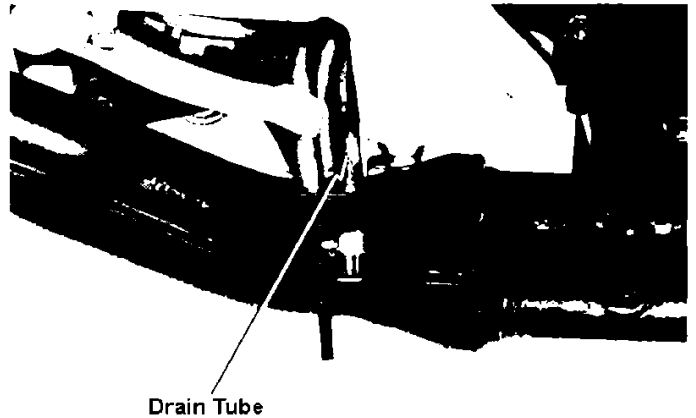

### (Valve clearance)

- Inspection/Adjustment should be when the engine is cold ( 35° C).
- Tilt the vehicle and let the remaining oil return to the crank case from cylinder heads.

Tappet clearance (cold engine)

IN : 0.13 – 0.19 mm  
EX : 0.20 – 0.26 mm.

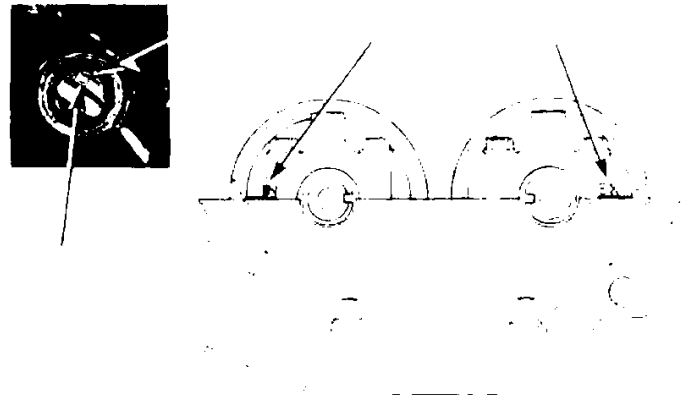

Remove the cylinder head cover (7-3).  
Remove the crankshaft bolt cap.  
Rotate the crankshaft clockwise and bring the marked lines on the cam gears parallel to the top surface of the cylinder head and facing outwards for both IN and EX sides.

Measure the No.1 tappet clearance by inserting the thickness gauge between the cam and the valve lifter.

Rotate the crankshaft clockwise and this time bring the lines perpendicular to the cylinder head surface and "IN" side upwards and "EX" side facing downwards.

Measure the No.2 tappet clearance in the same manner.



- Rotate the crankshaft clockwise. This time, the lines should be parallel to the cylinder head surface and facing inwards for both sides.
- Measure the No.4 tappet clearance in the same manner.

Rotate the crankshaft. Cam gear lines should be perpendicular to the cylinder head "IN" should face downwards and "EX" upwards. Measure the No.3 tappet clearance.

### ADJUSTMENT

Remove the cam shaft (7-3).  
Remove the valve lifter.  
If it is difficult to remove, use a valve flapper.

It may come out while the shim is still attached to the valve lifter.

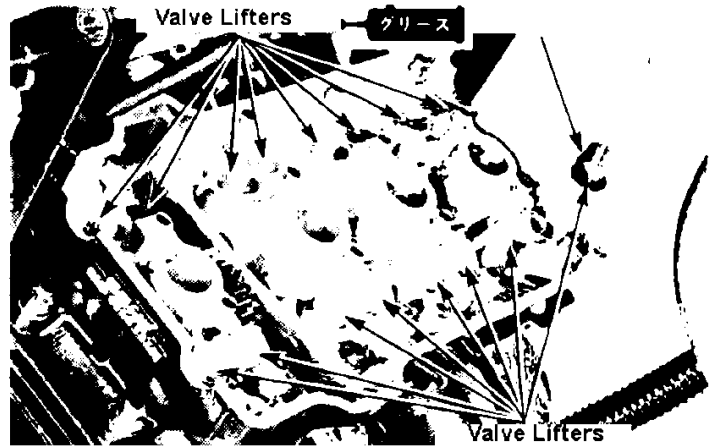

Remove the shim.  
Use a magnet or tweezers if necessary to remove.  
Clean the shim attachment on the retainer with air.

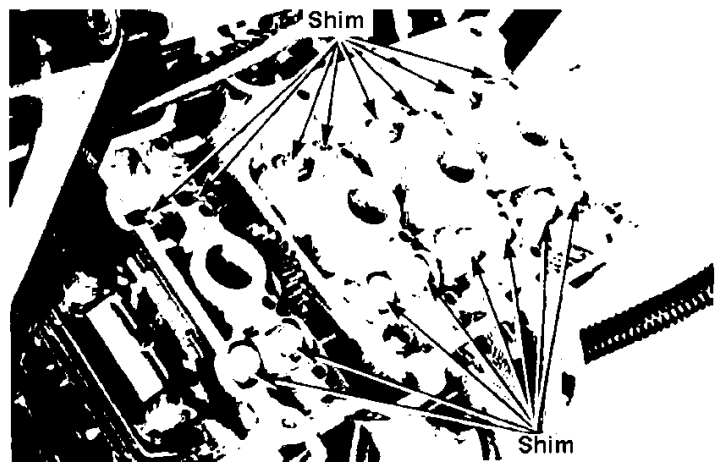

Wipe the oil off from the shim and measure its thickness with a micrometer.



### How to select a proper shim

There are 65 different shims ranging from 1.2mm to 2.8mm, in 0.025mm steps.



1.80mm



1.825mm



1.85mm



1.875mm

Required shim thickness : a  
 Recorded tappet clearance; b  
 Specified tappet clearance : c  
 Attached shim thickness : d

$$a=b-c+d$$

### (Example)

Intake tappet clearance 0.06 mm - b  
 Attached shim thickness 1.875mm - d  
 Specified tappet clearance 0.16 mm - c

$$A=0.06 - 0.16 + 1.875 \\ =1.775.$$

- Use a micrometer to measure the new and the attached shims' thickness.
- If the required shim thickness is greater than 2.80mm, remove carbon from a valve seat and adjust the seat.

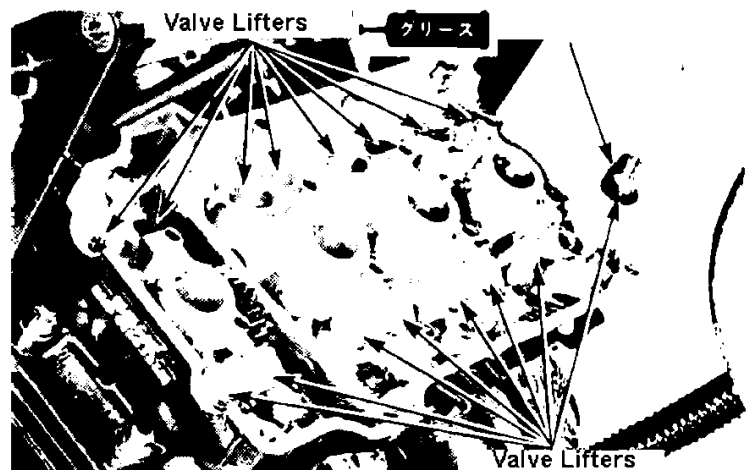

Attach the selected shim.

Apply MoS2 on the valve lifter and attach it.

Install the camshaft (7-19).

Rotate the crankshaft for a couple of times and allow the shims to fit and re-inspect the tappet clearance.

Attach the cylinder head cover (7-21).

### Cylinder compression

Measure after warming up.

Remove all spark plug caps (2-10).  
 Remove the spark plug for the cylinder you want to measure.  
 Set the compression gauge attachment to the plug screw hole and connect with a compression gauge.

Exclusive tool : Compression gauge attachment 07GMJ-KT70100

Measuring tool :  
 Compression gauge 07305-0010000

Fully open the throttle.  
 Engage the starter motor and measure the compression.

Do not crank for more than 7 seconds to avoid flattening the battery.

### Lubrication

(Oil quantity and condition).

- The vehicle should be straight up when inspecting oil level.
- Warm up the engine for 2~3 minutes. Then conduct the inspection after allowing 2~3 minutes after shutdown.

Inspect the oil level but do not screw the level gauge in.  
 If the level is below the minimum line, supply the specific oil up to the maximum line.  
 If the oil is too dirty, change the oil.

Specified engine oil:

Genuine Honda oil Ultra GP.  
 4-cycled motorcycle SAE 10W-40 or SAE20W-50

Follow the table 3-2 and use the adequate viscosity oil corresponding the local temperature.

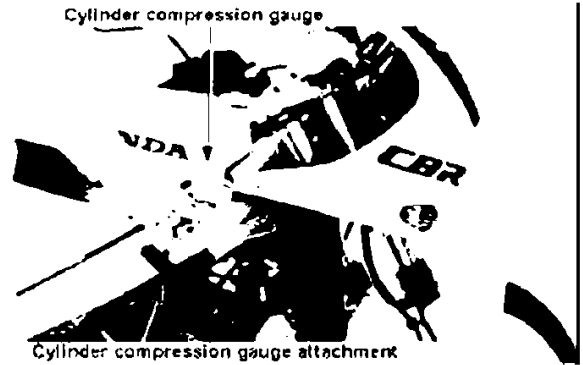

Cylinder compression gauge attachment.  
 If the compression is LOW, inspect the following items:

- Valve compression leak.
- Inadequate tappet clearance.
- Cylinder head gasket failure.
- Piston ring worn out (9-4).
- Piston/Cylinder worn out (9-5).

If too HIGH, inspect the following:

- Carbon on the piston head, cylinder head.

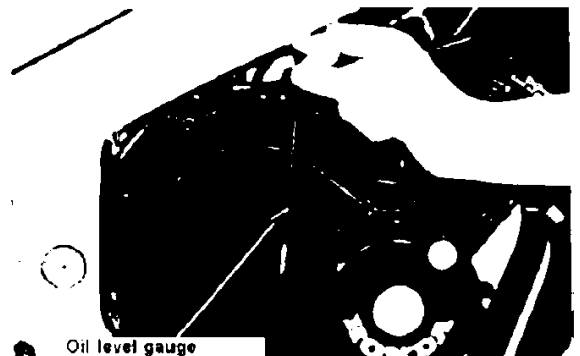

### Oil Change

Drain the oil after warming up the engine and oil.

- Remove the oil level gauge.
- Remove the drain bolt and drain all oil.
- Turn the kill switch OFF and engage the starter for 2~3 seconds and drain the remaining oil.
- Attach the drain bolt after cleaning.
- Tightening torque : 3.5 ~ 4.0kg.m.

Replace the sealing washer.

Supply the specific engine oil.

Engine oil capacity :

Oil change - 2.2l

Oil/filter change - 2.4l

Engine disassembled - 2.7l

After confirming no oil leak, check the oil level.

### (Replacing the oil cleaner)

Recommended replacement interval:

Initial : 1,000kms.

12,000kms after initial change.

- Drain the oil.
- Remove the oil filter cover by removing the filter attachment bolts.
- Remove the oil filter.
- Remove the O-ring and apply oil.
- Attach a spring and the new oil filter and attach an oil filter cover
- Tighten the filter attachment bolt. Tightening torque : 1.5~2.0kg.m.
- Fill the specific oil.
- After checking no oil leak, check the oil level.

### (Fuel System)

(Throttle valve and choke lever).

Inspect the free movement of the throttle grip.

Free movement : 2~6mm.

Inspect the throttle cable for damage.

Confirm the smooth movement of the throttle grip in all steering direction.

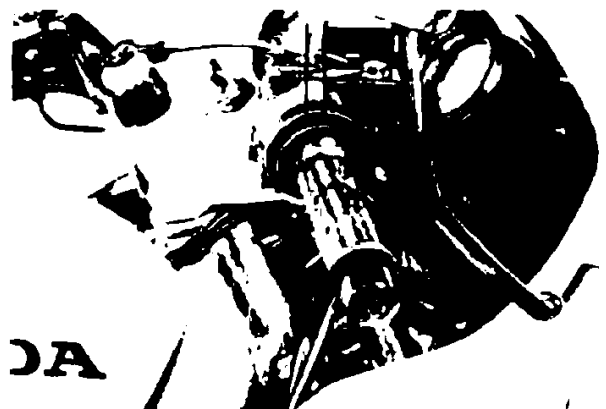
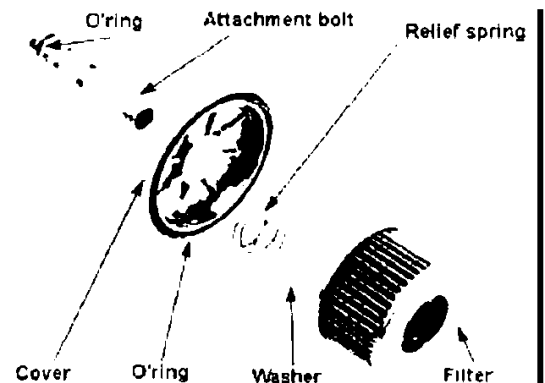
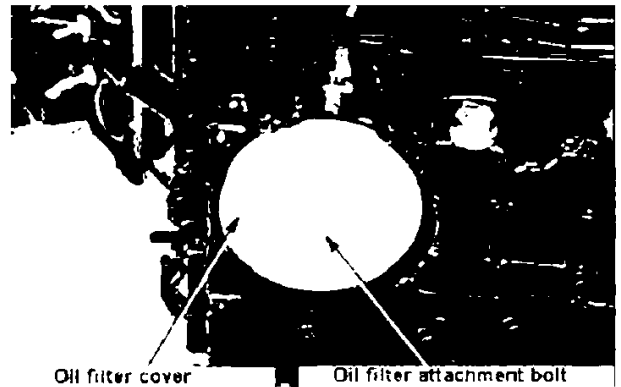
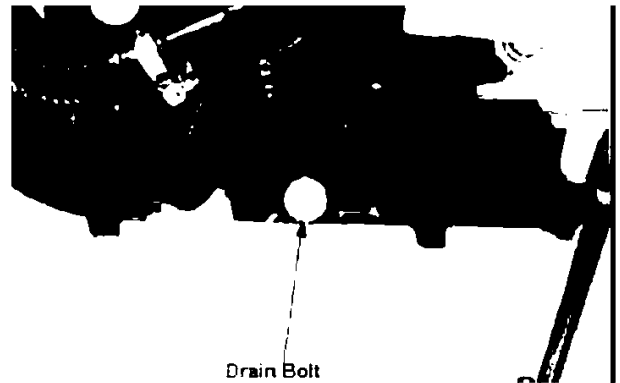



The adjustment of the free movement should be done at the carburettor section.  
Remove the fuel tank (4-3).  
Loosen the locking nut of the throttle cable on pulling side and adjust the free movement by rotating the main adjuster.

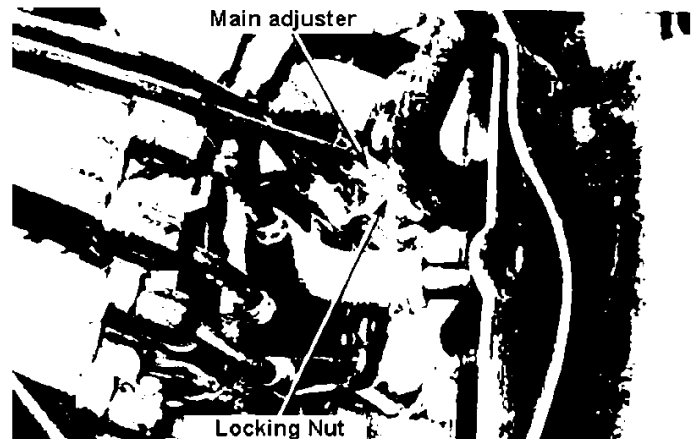

Precise adjustment should be done at the throttle holder section.  
Loosen the locking nut and adjust by rotating the sub-adjuster.  
If still unable to have standard or smooth movement, replace the throttle cables.

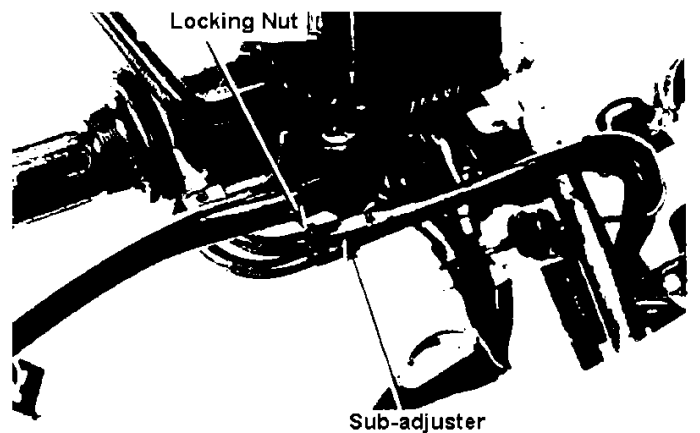

Inspect the smooth movement of the choke lever from fully closed to fully opened.  
Inspect the cable for wear, damage and twist.

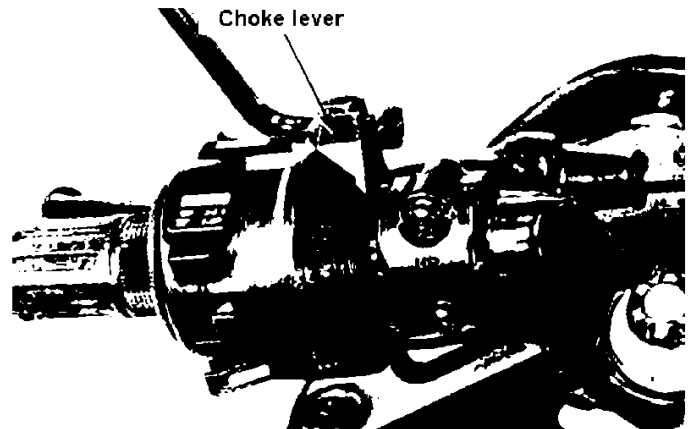

Check the movement of the carburettor bistarter valve by moving the choke lever.  
Loosen the choke cable clamp and shift the cable clamping position for adjustment.

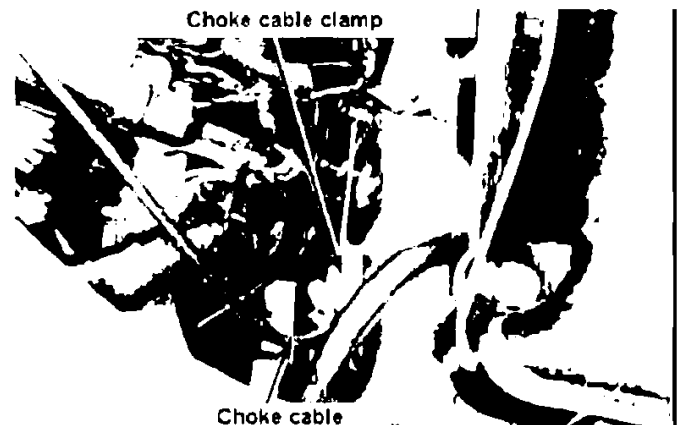

### (Clogged fuel strainer)

Remove the seat, fuel tank attachment bolts and nuts.  
Turn the fuel cock OFF.  
Remove the strainer cup, and remove the O-ring and the strainer screen from the fuel cock body.  
Clean the strainer cup and the screen with washing oil.  
Attach the strainer screen to the cock body.  
After attaching the new O-ring, tighten the strainer cup.

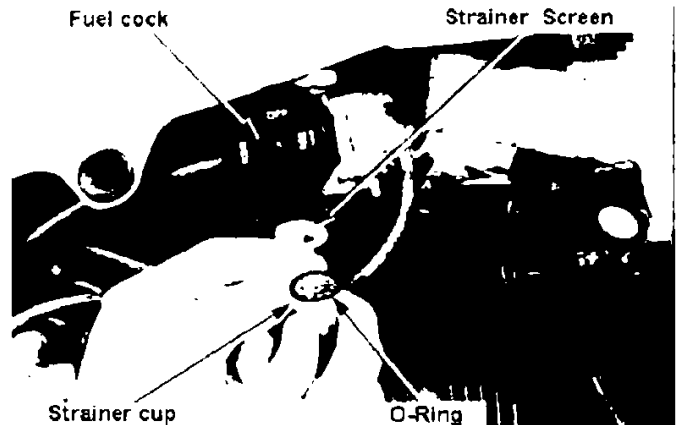

Do not over tighten the strainer cup.

Turn the fuel cock ON and check no fuel leak.

### Cooling System (Water level)

- When inspecting the radiator water level, place the body vertically.
- Inspect the water level at the reserve tank.

Remove the righthand side cover.  
Check that the water level in the reservoir tank is between UPPER and LOWER.  
If the level is below LOWER, refill the specified radiator liquid to UPPER line.  
Specified radiator liquid:

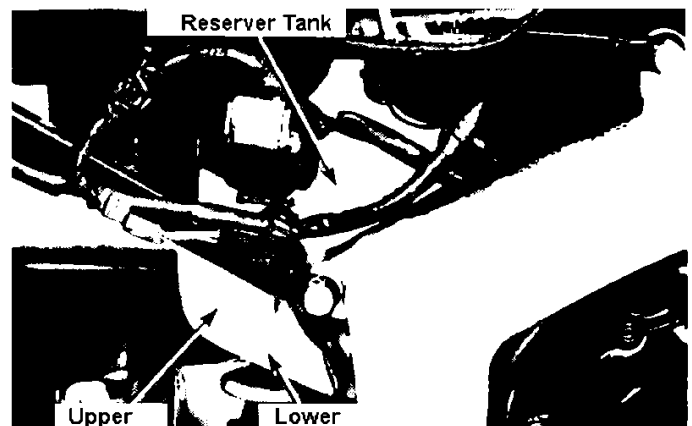

Genuine Honda Ultra radiator liquid.  
(30% standard concentration)

### Lighting system - (Head light)

Use a screwdriver to rotate vertical adjustment screw to adjust the vertical axis of the headlight.

Remove the rear fairing inside cover.

Rotate horizontal direction adjust screw to adjust the horizontal axis of the light.

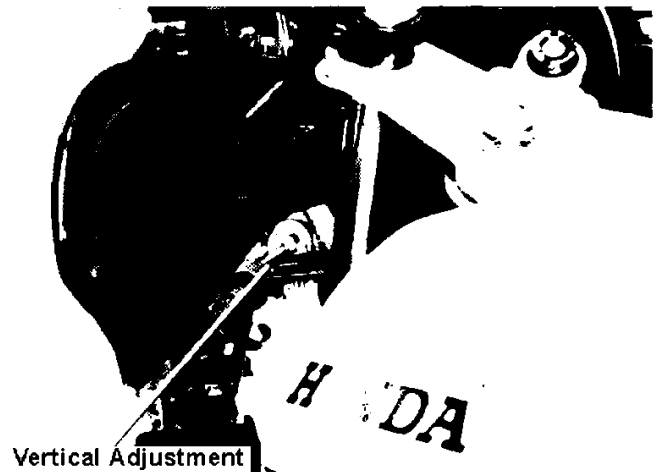
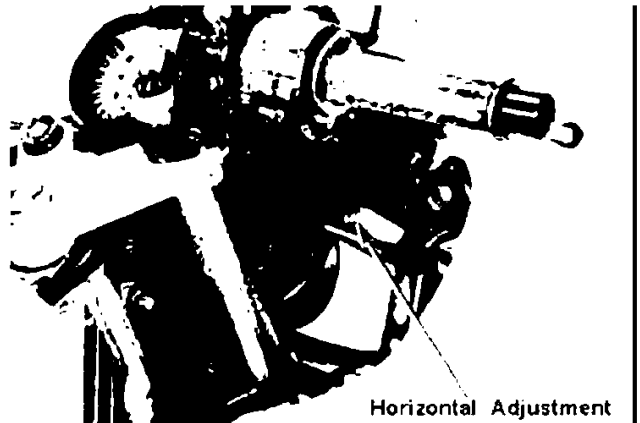

### (Stop light/Brake light)

Conduct after adjusting the brake pedal height.

Adjust by rotating the adjuster while holding the stoplight switch so as to illuminate the light when the brake pedal is pushed for 20mm.  
After adjusting, check by pressing the brake pedal.

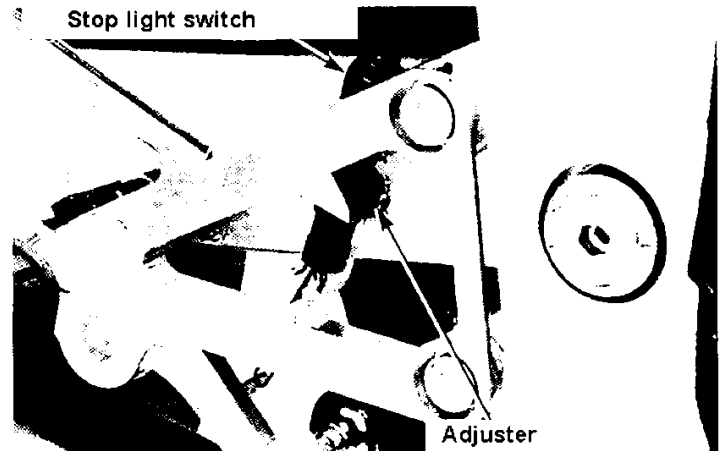

There is no need to adjust the front brake light switch.

### Side stand

Support the frame and lift the rear wheel. As shown in the figure, apply 2.0~3.0kg. load on the edge of the stand and confirm its retraction.

If there is no smooth movement, apply grease on the pivot area.

If it retracts too easily, inspect the wear of the side stand spring?.

Inspect for lateral tension. Tighten the pivot bolt if it is loose.

Inspect the side stand rubber and replace the rubber if it is worn out till the limit line.

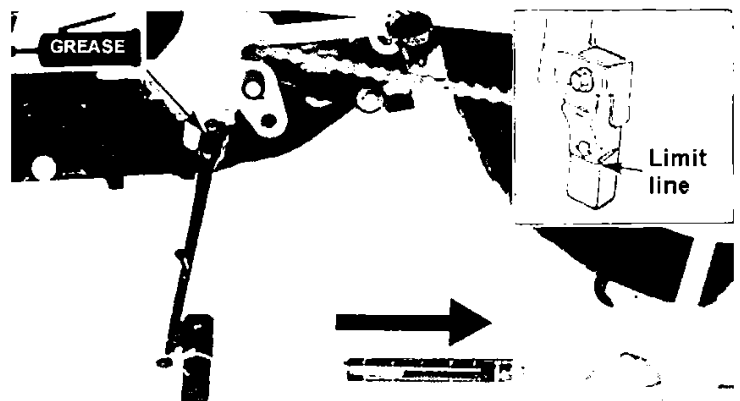

### Tightening torque:

**Side stand bracket : 2.5~3.0kg-m.**

# CBR250R,RR System

## 3. Oil Lubrication

### • Assembly

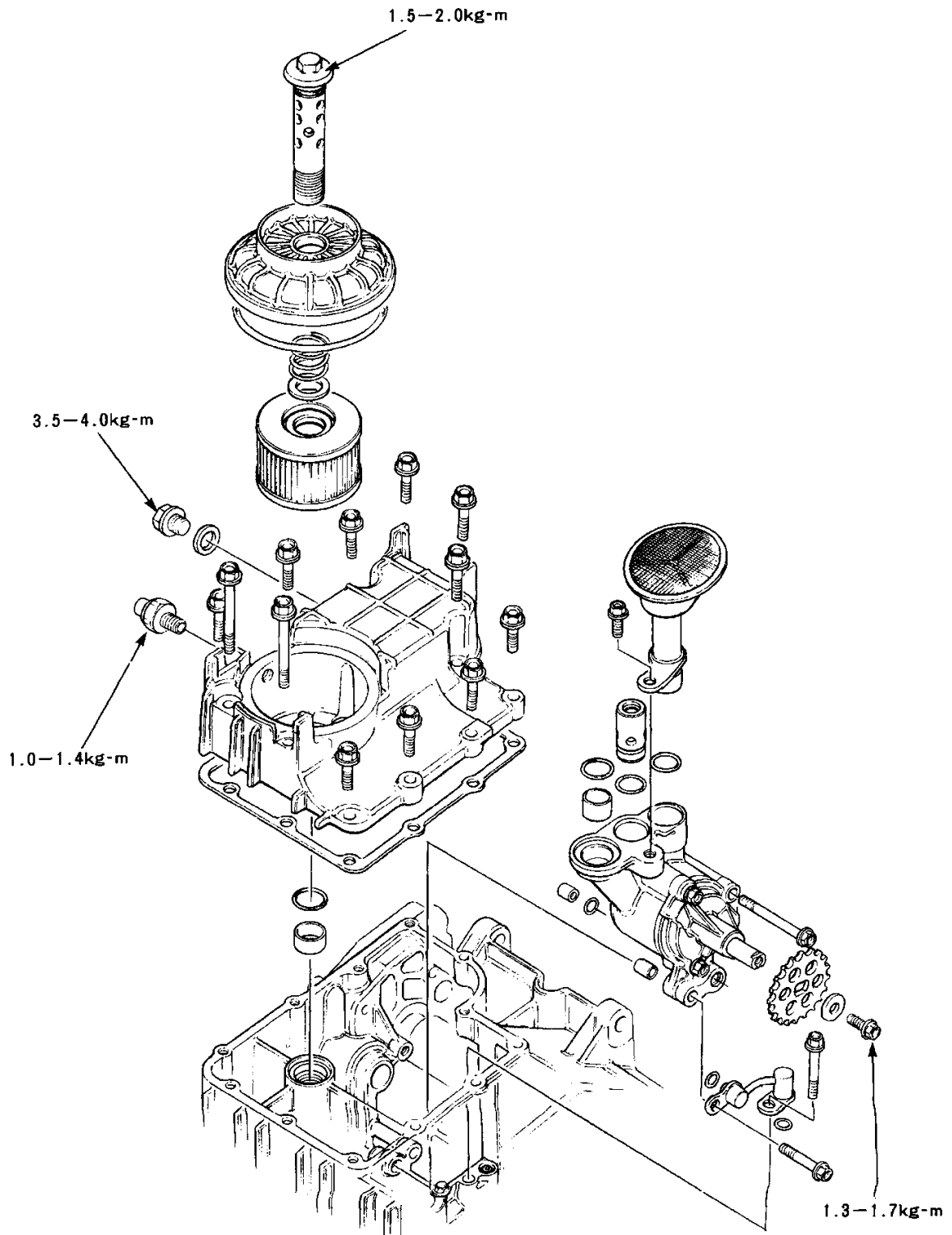

- Lubrication System Diagram

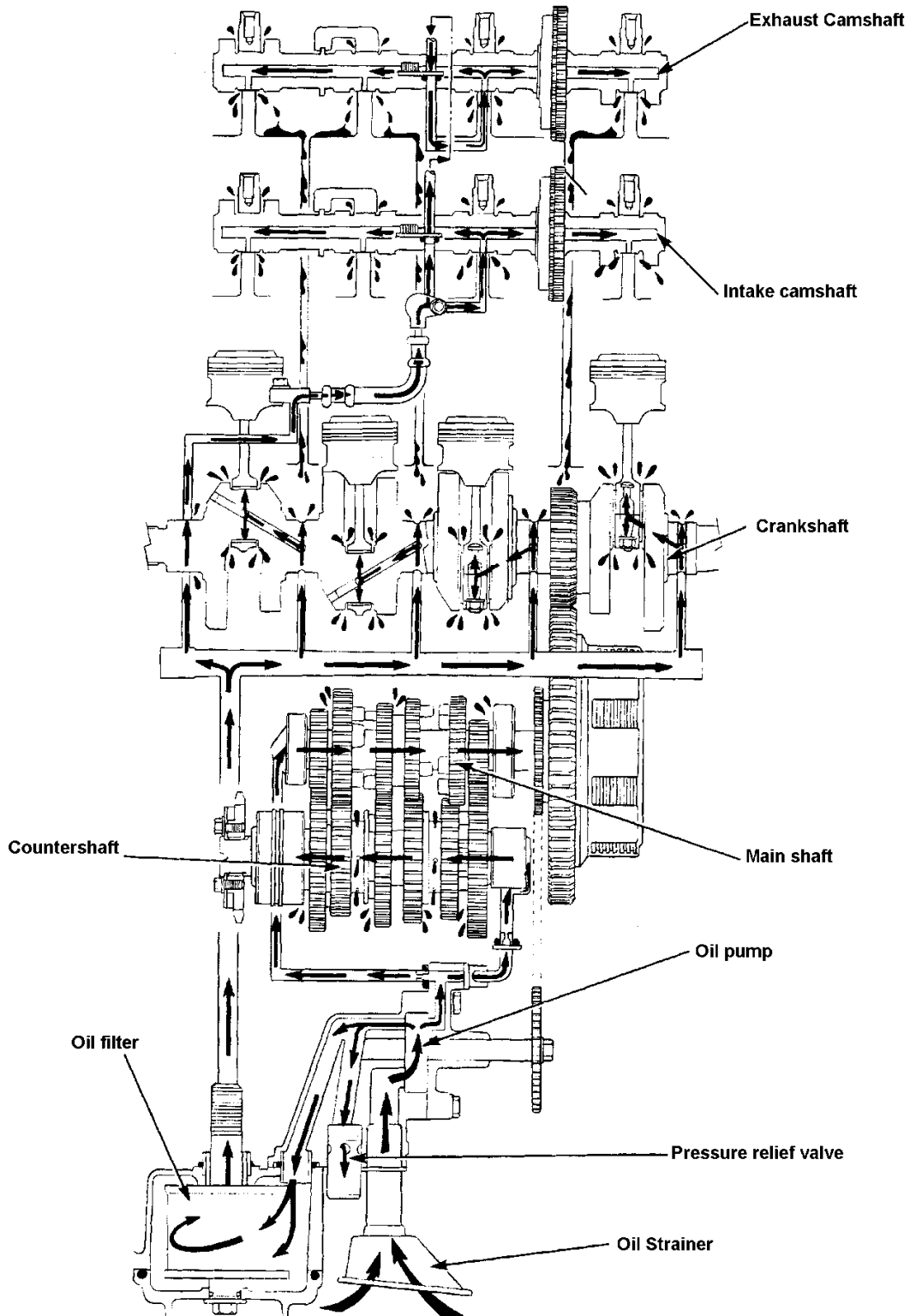

# CBR250R,RR System

## 3. Oil Lubrication

Assembly	3 - 0	Removing the oil strainer pressure relief valve	3 - 4
Lubrication Diagram	3 - 1	Removing the oil Pump	3 - 5
Maintenance Information	3 - 2	Attaching the oil pump	3 - 8
Troubleshooting	3 - 3	Attaching the oil strainer pressure valve	3 - 8
Oil Pressure	3 - 4		

### • Maintenance Information

#### General Caution

- All of the works on this chapter can be done on the vehicle.
- Do not allow debris to enter the engine when removing an oil pump.
- Replace by assy when the oil pump is on its limit.

### • Maintenance Standard

Item	Standard	Standard	Limit
Oil Pump	Rotor tip clearance	0.15	0.20
	Pump body - outer rotor clearance	0.15 - 0.22	0.35
	Rotor body clearance	0.02 - 0.07	0.10
	Pump out pressure	4.0-5.0kg-cm <sup>2</sup> (6,000 rpm,60°C)	

Engine Oil Capacity	2.2 litre (Oil Change), 2.4 litre (oil/filter change) 2.7 litre Total Capacity	
Specified Engine Oil	Genuine Honda Oil Ultra GP (4 cycle Motorcycle) (SAE10W-40 or SAE20W-50)	
		<ul style="list-style-type: none"> <li>• Find out the proper oil grade corresponding to local temperature</li> </ul>

### Tightening Torque

- Oil drain bolt 3.5 - 4.0kg-m
- Oil filter attachment bolt 1.5 - 2.0kg-m
- Oil pressure switch 1.0 - 1.4kg-m
- Oil Pump driven sprocket bolt 1.3 - 1.7kg-m

### Tools

- Exclusive tools
- Oil pressure gauge attachment 07510 - 4220100
- Measuring tools
- Oil Pressure gauge 07510 - 3000000

### • Troubleshooting

#### Low oil level

- Naturally consumed the oil.
- Oil leak.
- Piston ring worn out.
- Valve guide or seal worn out.

#### Dirty oil

- Unchanged/Out of Service.
- Head gasket failure.
- Piston ring worn out.

#### Low oil pressure

- Low oil level.
- Pressure relief valve does not close.
- Oil strainer clogged.
- Oil pump worn out.
- Oil leak.
- Improper oil grade.

#### High oil pressure

- Pressure relief valve does not open.
- Oil filter, oil tube, orifice clogged.
- Improper grade of oil.

#### No oil pressure

- Low oil level.
- Oil pump drive sprocket failure.
- Oil pump drive chain failure.
- Oil pump failure.
- Internal oil leak.



# CBR250R,RR System

## 3. Oil Lubrication

### • Oil Pressure Inspection

Conduct after warm up.

Remove the cover and screw for oil pressure switch.  
Disconnect the oil pressure warning light wiring.  
Remove the oil pressure switch.  
Connect the oil pressure gauge to the pressure switch hole.  
Inspect the oil quantity.  
Start the engine and measure the oil pressure at 6000 rpm.

**Standard Oil Pressure :4.0~5.0kg/cm<sup>2</sup> (6000rpm, oil 60°C)**

Shutdown the engine.  
Apply sealer on the screw of the oil pressure switch and tighten.

**Tightening torque : 1.0-1.4kgm.**

Connect the oil pressure warning light wiring.  
Restart the engine and check the warning light turns off  
1~2 seconds after starting.  
Exclusive tool : Oil pressure gauge attachment 07510-4220100.  
Measuring tool: Oil pressure gauge 07506-3000000.

### Oil strainer, pressure relief valve

Remove the cover and screw for oil pressure switch.  
Remove the exhaust pipe (16-2).  
Drain engine oil (2-17).  
Remove the oil filter attachment bolt.  
Remove 12 bolts and remove oil pan, gaskets.  
Remove the bolts and remove the oil strainer from oil pump, clean the strainer.  
Remove the oil pressure relief valve.  
Remove O-ring and knocking pin.

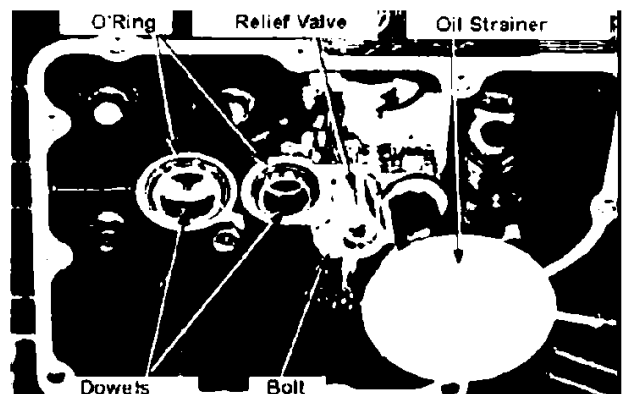
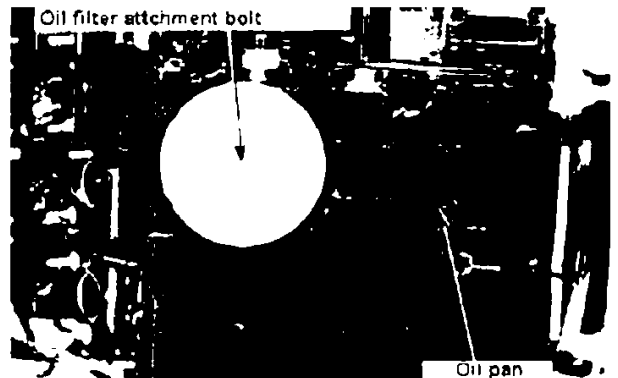
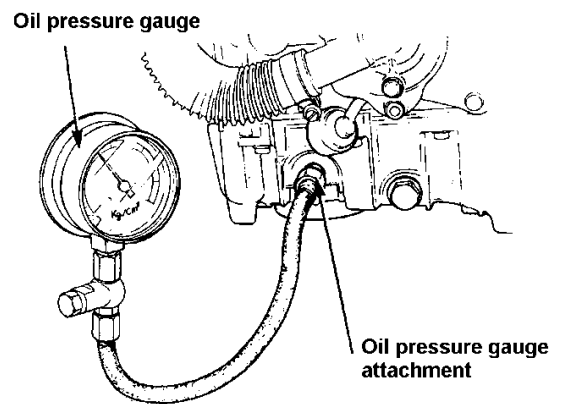
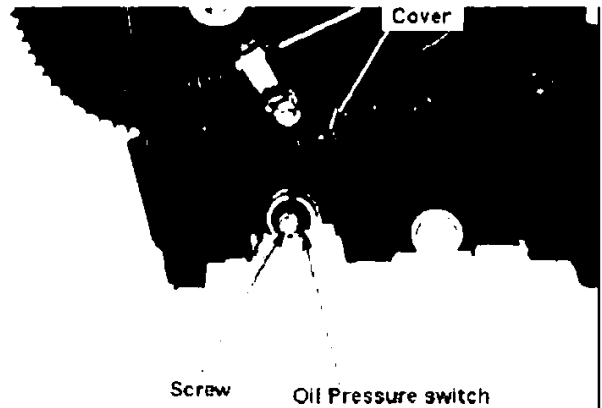

# CBR250R,RR System

## 3. Oil Lubrication

- **Detaching the Oil Pump**

Remove the oil strainer, pressure relief Valve (3-4).

Remove bolts and washers and detach the driven sprocket with drive chain from oil pump drive shaft.

Remove three bolts and detach the oil pump, oil pipes.

Remove the dowels.

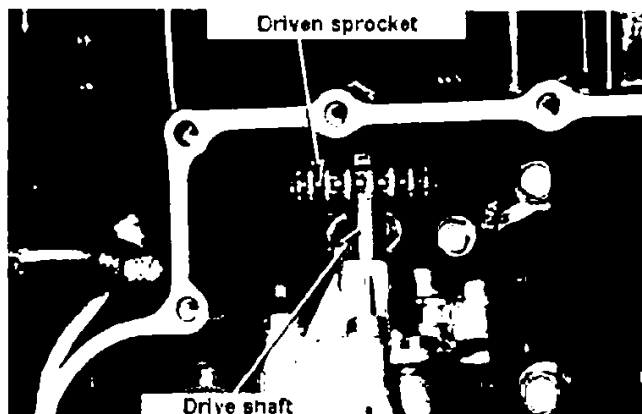

- **Disassembly of Relief Valve**

Remove the snap ring and disassemble the relief valve body.

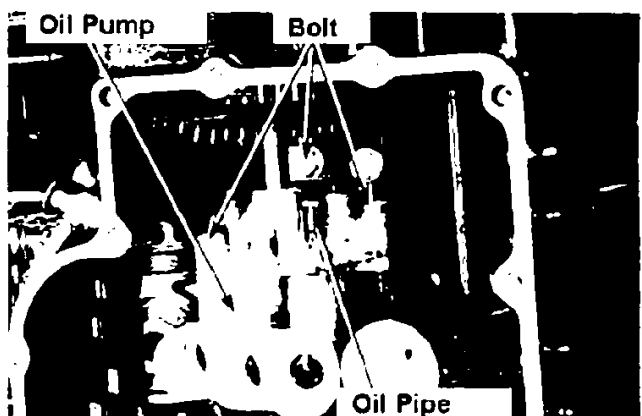

- **Inspection, Assembly of Relief Valve**

Inspect for damages on the spring and valve.

Re-assemble the relief valve.

Inspect the O-ring for damage/wear.

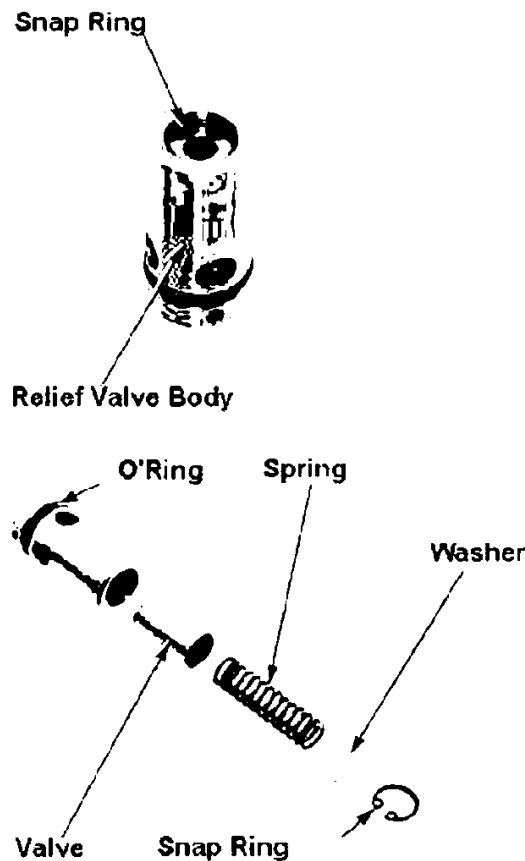

### Oil Valve Inspection

Inspect the pipe for jam/leak.  
Inspect the O-ring for wear/damage.

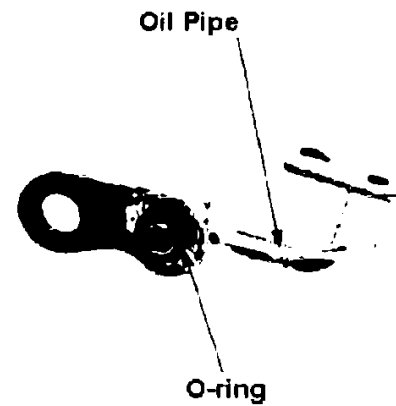

### Disassembly/Inspection of Oil Pump

Remove the two bolts and remove the oil pump cover.  
Remove the dowels.

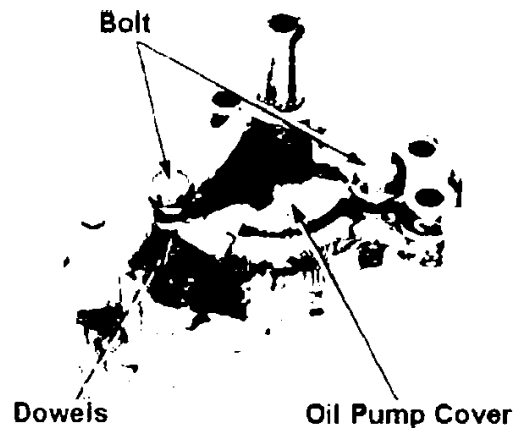

Measure the clearance between the oil pump body and the Outer rotor.

**0.35mm or more → replace.**

Measure the clearance between the inner rotor and outer rotor (tip clearance).

**0.20mm or more → replace**

Remove the oil pump drive shaft.

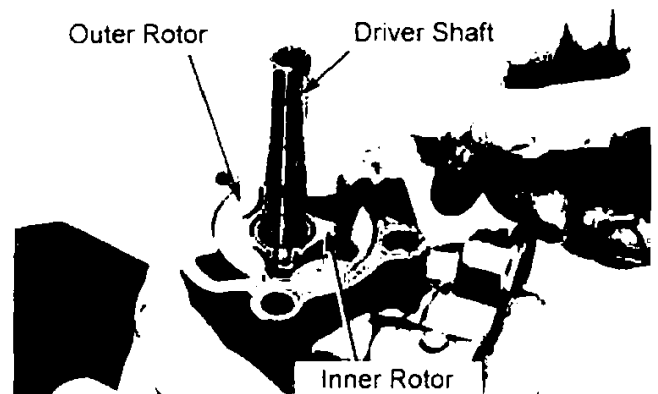
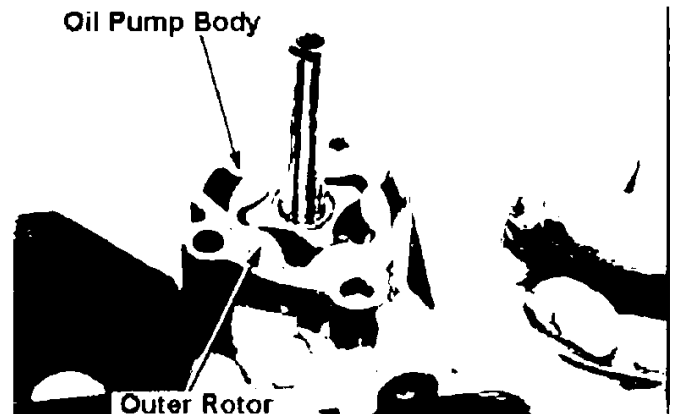

# CBR250R,RR System

## 3. Oil Lubrication

Measure the clearance between the edge surface of inner/outer rotor and the pump body.

0.10mm or more → replace.

### Assembly of the Oil Pump.

Clean each parts before assembly and keep them away from debris.

Apply the specified oil to the contact surface of the oil pump. Insert the pin in the pump shaft and attach the thrust washer. Align the key slit on the inner rotor and the pin and attach the drive shaft to the oil pump body.

Attach the dowels to the oil pump body.

Attach the oil pump cover.

Attach two bolts and rotate the drive shaft to check for smooth movement.

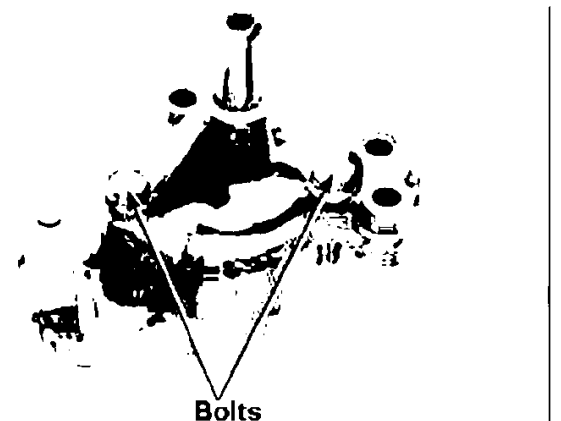
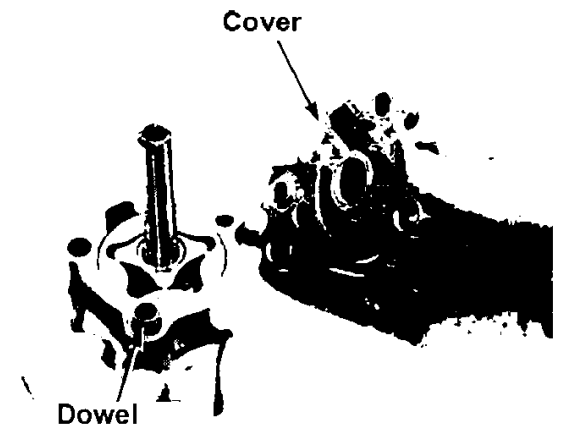
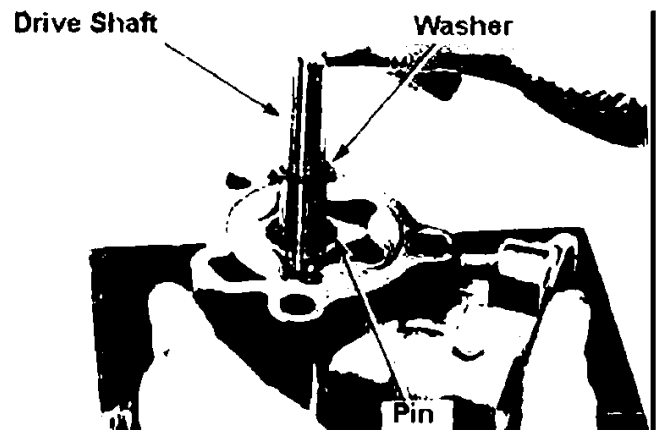

# CBR250R,RR System

## 3. Oil Lubrication

### Attachment of the Oil Pump

Attach the dowel.  
Apply oil to the O-ring and attach.

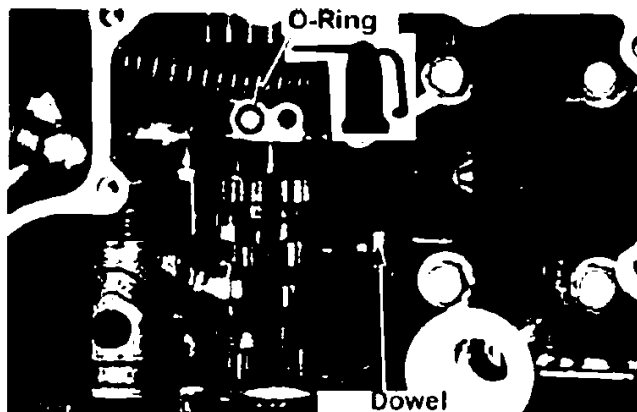

Attach the oil pump, oil pipe and tighten the three screws.

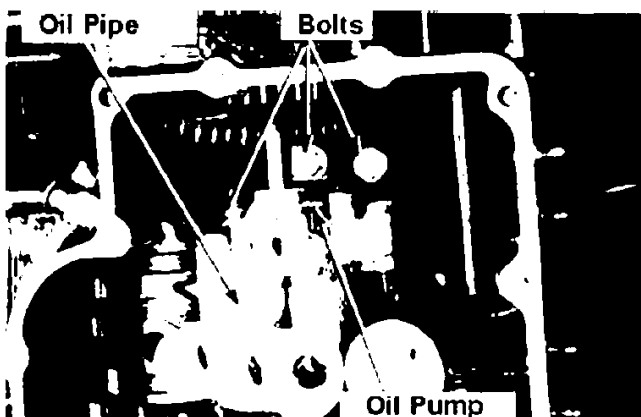

Attach the drive chain to the oil pump driven sprocket and attach to the drive shaft.  
Apply locking agent to the bolt and tighten with washers fitted.

Tightening torque : 1.3~1.7KGm

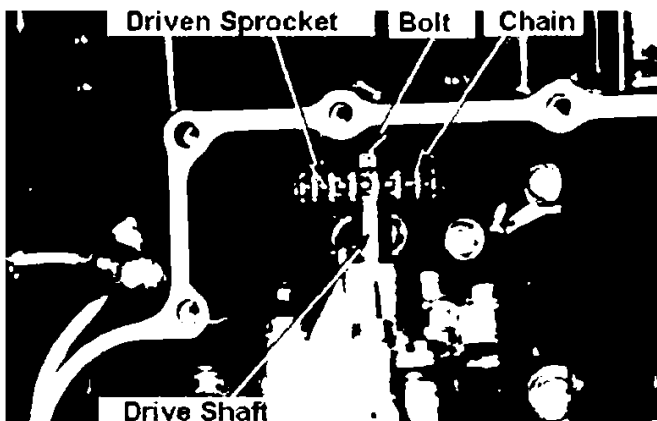

### Attachment of the Oil Strainer Pressure Relief Valve

Apply oil to the pressure relief valve's O-ring and attach to the oil pump.

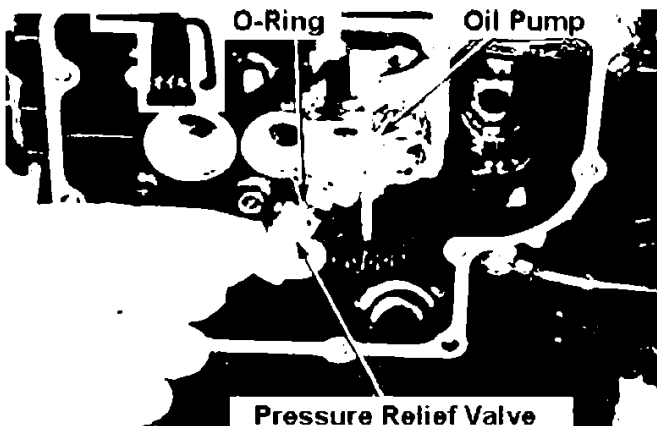

# CBR250R,RR System

## 3. Oil Lubrication

Apply oil to the O-ring for the oil strainer and attach to the oil pump.

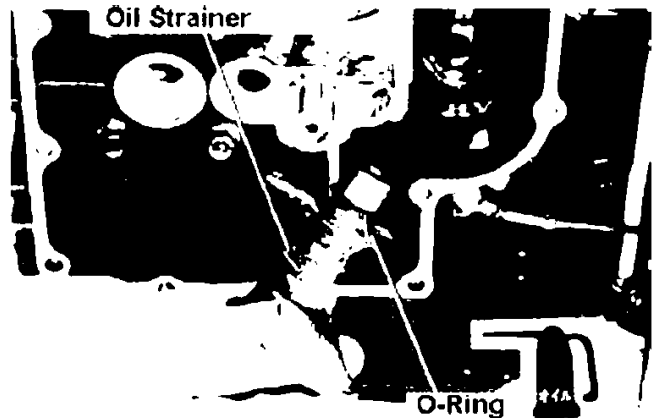

Tighten the bolt for the oil strainer. Attach the dowel, attach the O-ring after applying oil on it.

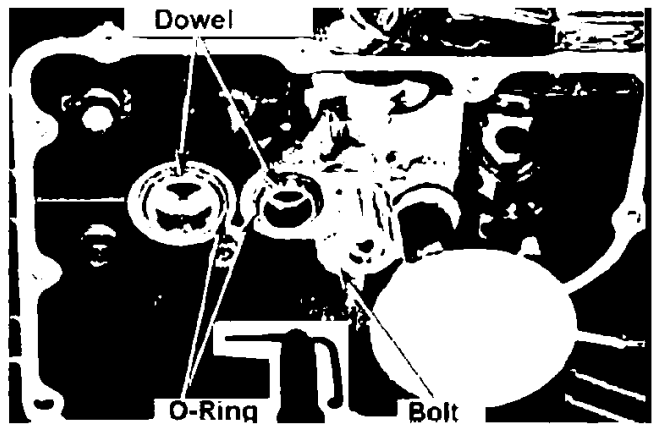

Clean the oil pan and attach with new gaskets.

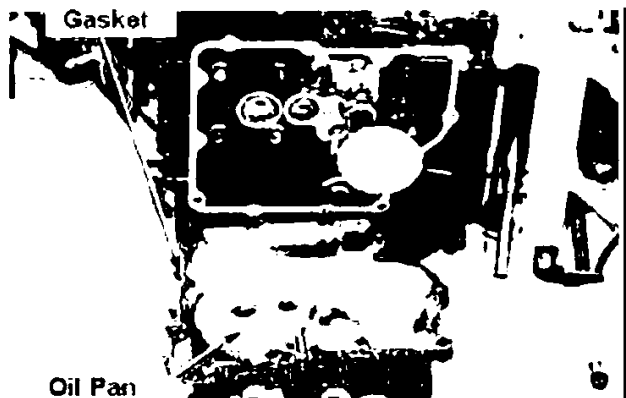

Attach 12 oil pan attachment bolts. Attach the oil filter attachment bolts.

**Tightening torque : 1.5~2.0kgm**

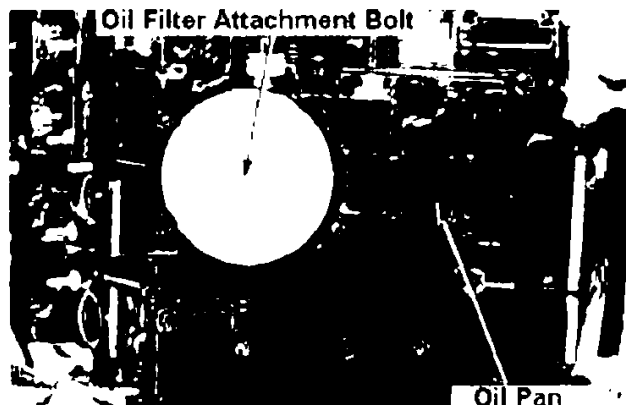

Tighten the oil pressure switch screw and attach the cover.

Fill the engine oil (2-17).

Attach the exhaust pipe (16-2).

Start the engine and confirm there is no oil leak.

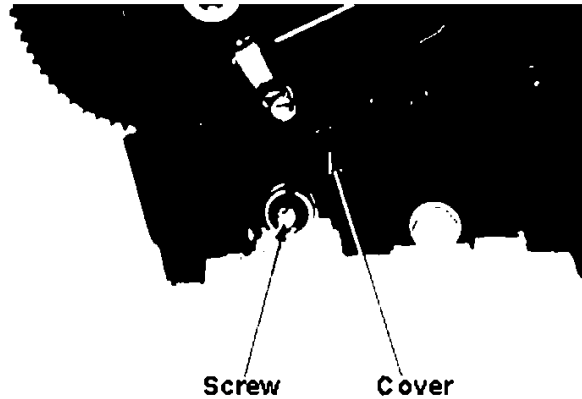

• Assembly

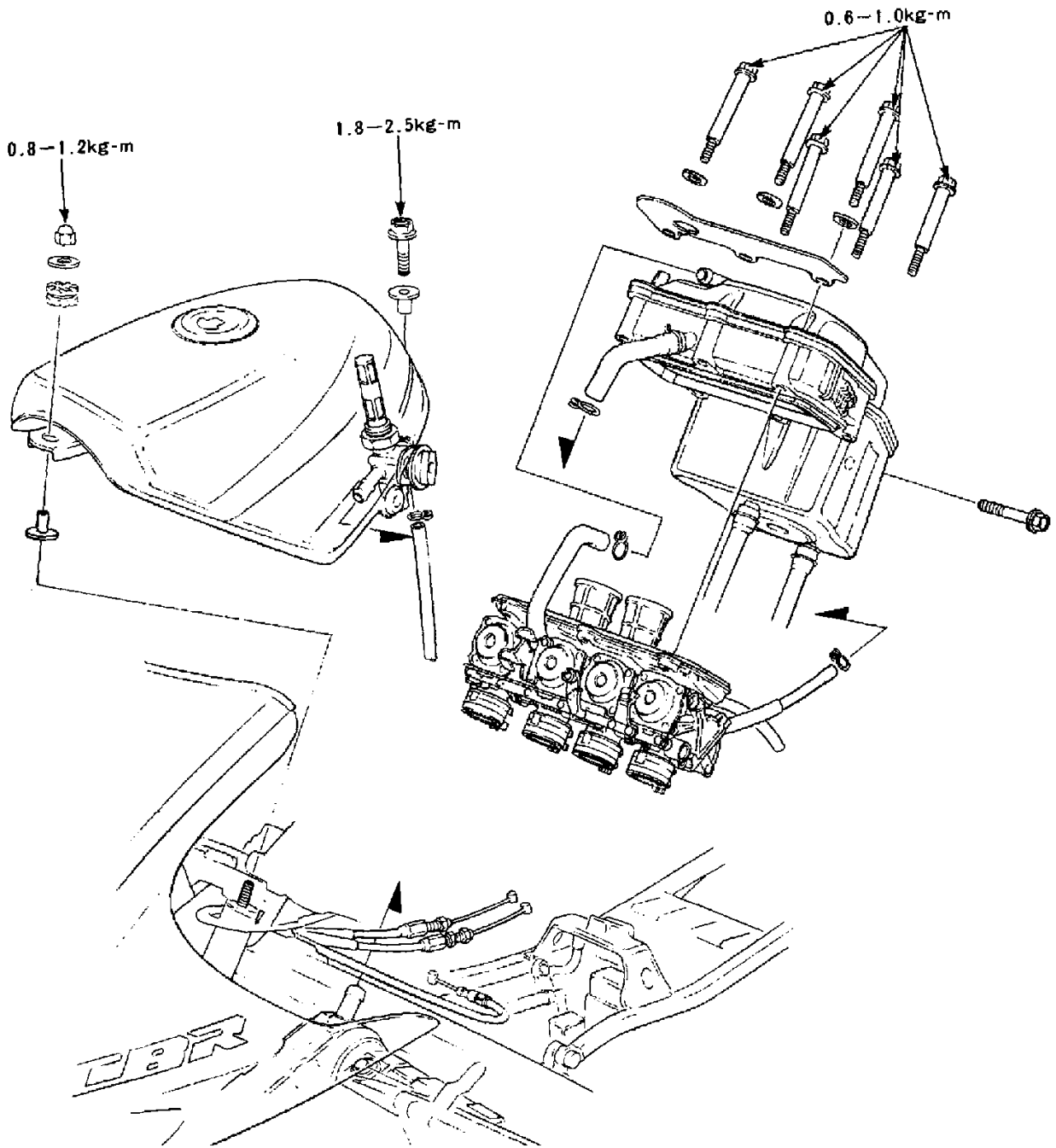



Assembly	4 – 0	Air cleaner case	4 – 6
Maintenance Information	4 – 1	Carburettor	4 – 8
Troubleshooting	4 – 2	Pilot screw adjustment	4 - 18
Fuel Tank	4 – 3	Carburettor synchronism adjustment	4 - 19
Fuel auto cock	4 - 4		

## • Maintenance Information

### General Caution

- Do not overstress the cables to bend or twist. Damaged or deformed cables may cause failure or binding.
- Exercise caution to avoid flames when handling fuel.
- Always check the position of O-Ring when installing them. Replace with new ones upon assembly.
- Before disassembly, loosen the drain screw in float chamber and collect the drained fuel with a tray.
- The vacuum chamber and float chamber are able to accessed without removing the carburettor.

### Maintenance Standard

Item	Standard Value	
Venturi Diameter	25mm	
Setting Mark	VG01A	
Fuel level	7mm	
Main jet	#85	
Slow jet	#35	
Idle speed	1,500 ± 100rpm	
Free movement of a throttle grip	2 – 6mm	
Air screw	2-½ turns	
	Total	14 l
	Reserve	2.5 l

### Tightening Torque

Fuel cock	2.0 – 2.5kg-m
Fuel tank attachment nut	0.8 – 1.2kg-m
Fuel tank attachment bolt	1.8 – 2.5kg-m
Air cleaner case	0.6 – 1.0kg-m
Air cleaner duct	0.5 – 0.8kg-m

### Tools

#### Common Tools

Float level gauge 07401 – 0010000

#### Measuring Tools

Vacuum gauge 07404 – 0020000

## • Fuel System Troubleshooting

### **Starter Engages, but fails to start**

- No fuel in a tank.
- Fuel is not reaching to the carburettor.
- The engine is flooded with fuel.
  - Clogged fuel filter.
  - Clogged fuel tube.
  - Float valve fixed in one position.
  - Inadequate fuel level.
  - Clogged air vent hole on a tank cap.
  - Fuel Auto cock failure.
  - Clogged/damaged vacuum tube.
- No sparks ( →Sec.18)
- Clogged air cleaner element.
- Manifold air leak.
- Throttle grip failure.

### **Difficult to start/starts but stops soon.**

- Faulty ignition (→sec. 18)
- Faulty synchronizing.
- Faulty carburetor.
- Bad quality fuel.
- Vacuum leak from manifold.
- Faulty bistarter valve.
- Choke lever, cable failure.
  
- Inadequate tappet clearance ( →Sec.2).

### **Unstable idling.**

- Faulty ignition (→18)
- Inadequate idling.
- Inadequate synchronizing.
- Faulty carburettor.
- Bad quality fuel.
- Clogged air filter.
- Vacuum leak from manifold.
- Inadequate tappet clearance (→2)

### **Misfire during acceleration**

- Faulty ignition (-> Sec 18)
- Too lean mixture

### **After burn**

- Faulty ignition (-> Sec18)
- Too lean mixture

### **Unable to achieve power/bad fuel consumption**

- Clogged fuel system
- Faulty igniton
- Clogged air cleaner element

### **Too Lean Mixture**

- Clogged fuel jet
- Faulty vacuum piston
- Faulty float valve
- Fuel level too low
- Clogged air vent on a fuel tank cap
- Clogged fuel strainer screen
- Clogged/bent/damaged fuel tube
- Clogged air vent tube
- Air from manifold
- Clogged fuel filter
- Faulty fuel auto cock
- Clogged./damaged vacuum tube
- Inadequate pilot screw adjustment

### **Too Rich Mixture**

- Choke lever fixed in pulled position
- Faulty float valve
- Fuel level too high
- Clogged air jet
- Dirt on air cleaner element
- Inadequate pilot screw adjustment

## FUEL TANK

### Removal

Watch out for flame.

Turn the fuel cock OFF.  
Remove the seat, side cover.  
Remove the tank attachment bolt/nut.

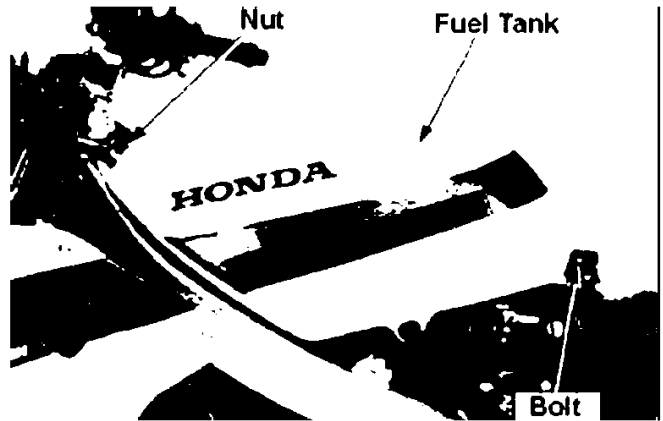

Remove the vacuum and fuel tubes and then the fuel tank.  
Ensure the air ventilation hole on a tank cap is not clogged.

### Installation

Reverse the above procedure.

Check for fuel leaks after installation.

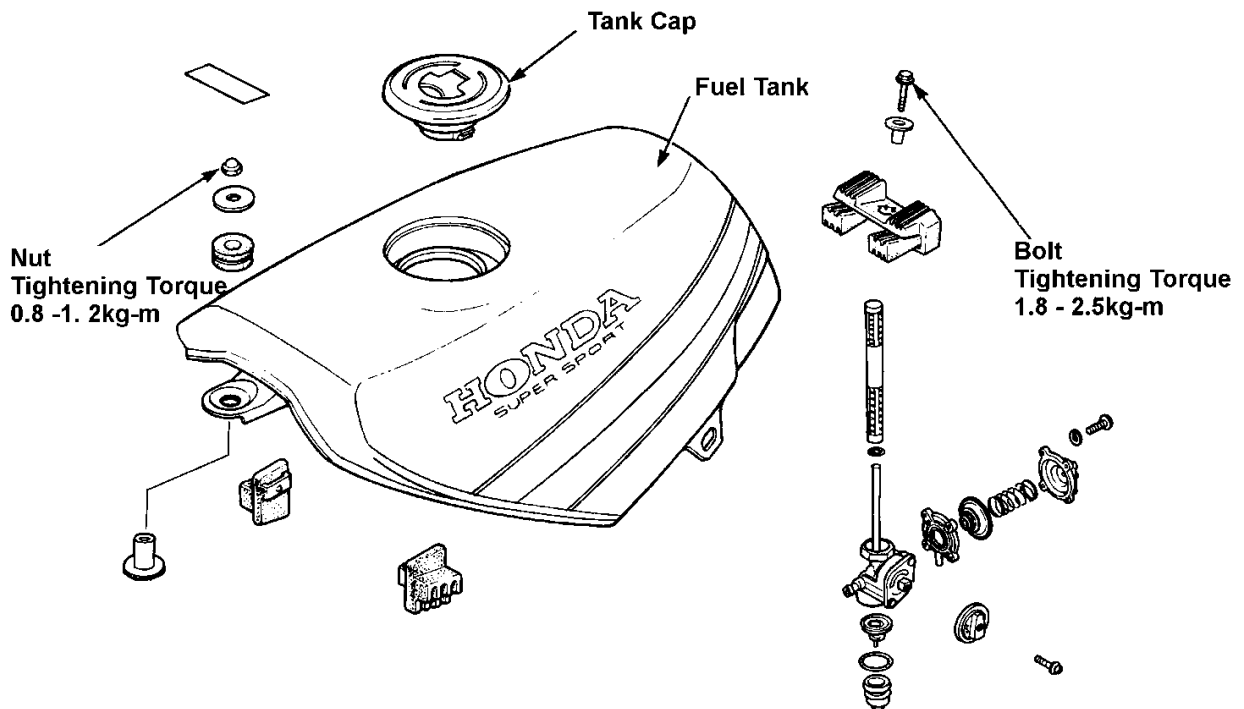
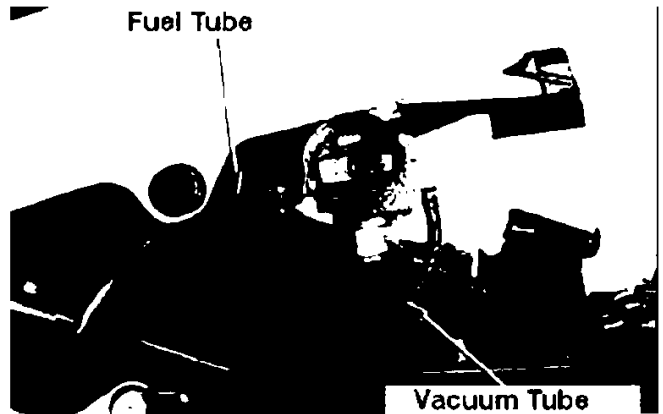

- Fuel Auto Cock

### Inspection

Remove fuel tank (4-3)

Apply negative pressure to the vacuum tube for fuel auto cock with a vacuum pump, and inspect the (proper) fuel flow.

If the flow is not smooth, inspect the fuel filter and vacuum diaphragm. If the fuel flows without applying negative pressure, replace the diaphragm.

**Place a clean tray underneath the fuel tube**

### Disassembly

Remove the fuel cock lever.

Remove the four screws and remove the diaphragm cover.

Remove the spring, diaphragm and the spacer.  
Inspect the diaphragm spring for wear/damage.

Inspect the diaphragm for wear, damage.

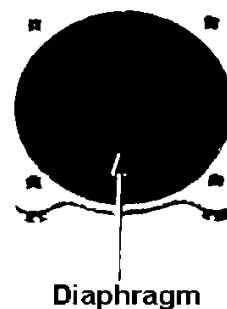
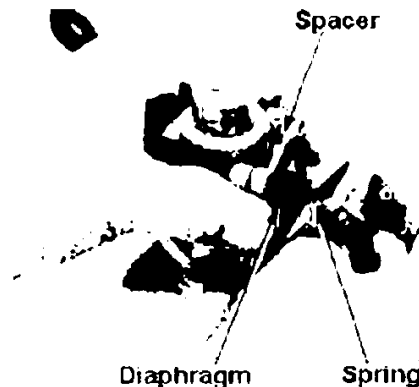
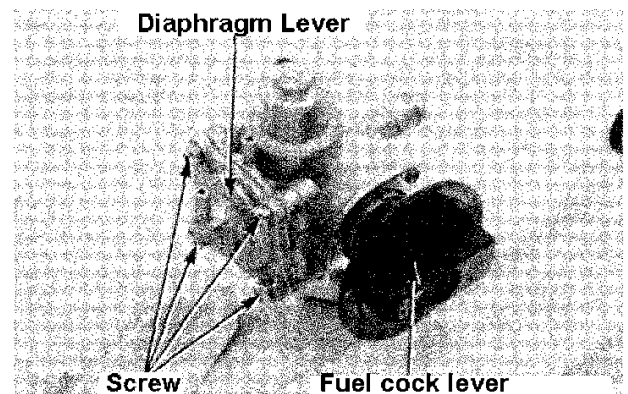
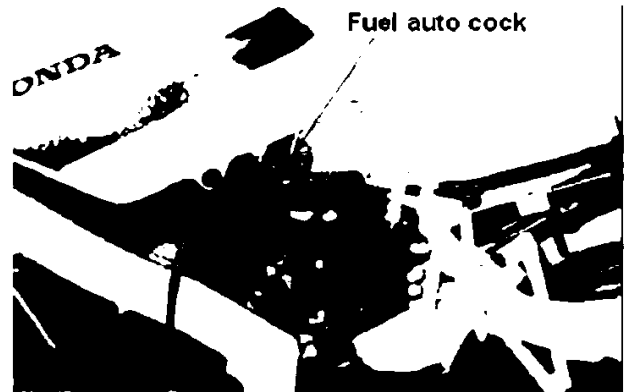

Remove the fuel strainer cap, O-ring, strainer screen.  
Clean the strainer screen.  
Inspect the O-ring for wear.

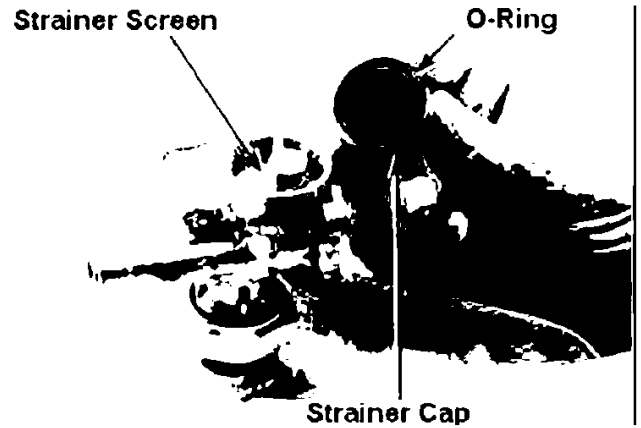

Loosen the locking nut and remove the fuel auto cock from fuel tank.  
Remove the fuel filter and the O-ring.  
Clean the fuel filter.  
Inspect the O-ring for wear.

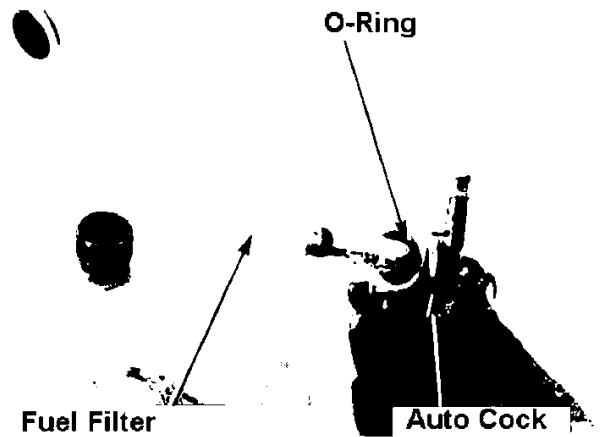

### Assembly

Attach the fuel filter and the O-ring to the fuel auto cock.

Attach the fuel auto cock to the tank.

Tightening torque: 2.0~2.5kg m

Do not overtighten the locking nut.

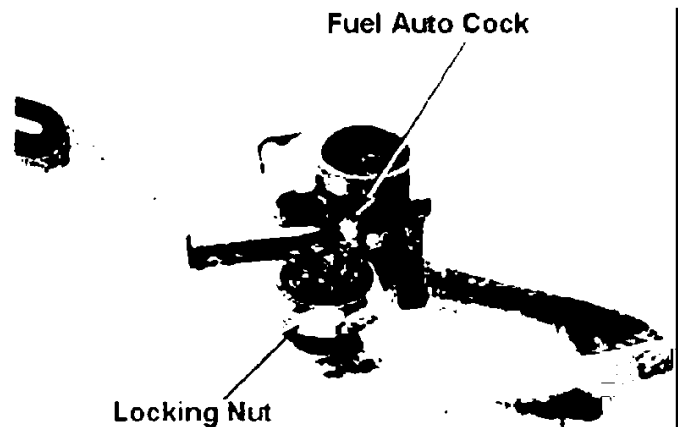

Attach the strainer screen.  
Attach the O-ring to the strainer cap and attach the cap to the fuel auto cock.

Do not overtighten the fuel strainer cap.

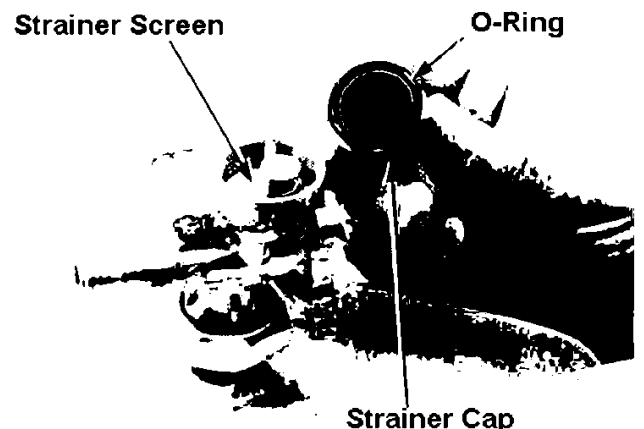

Attach the diaphragm to the spacer and attach to the fuel auto cock.

Align the spacer's projection with the hole on the fuel cock.

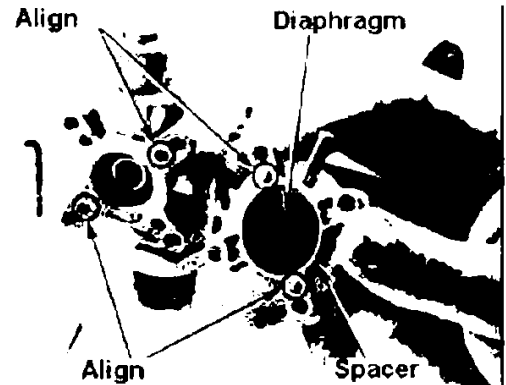

Attach the diaphragm spring and the diaphragm cover.

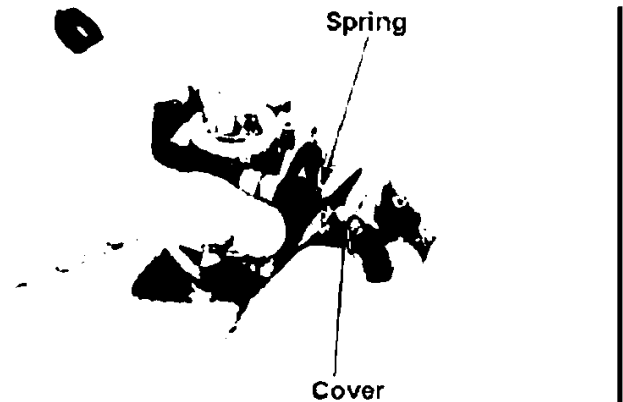

Tighten the four screws.  
Attach the fuel cock lever.  
Attach the fuel tank. (4-3).  
Inspect for fuel leaks.

- **Air cleaner case.**

- **Removal**

- Remove the fuel tank.
    - Remove the main harness from clamps on the air cleaner case.
    - Disconnect the breather tube from the air cleaner case.

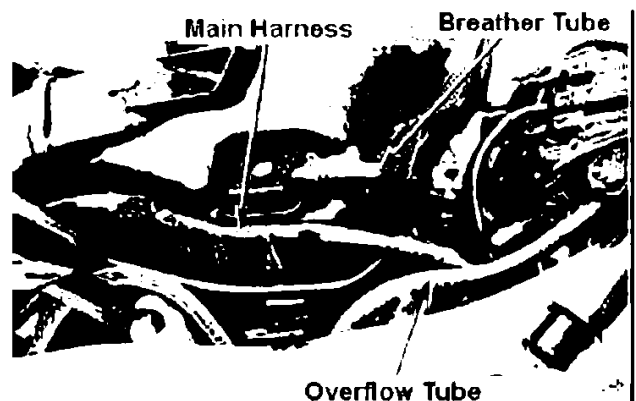
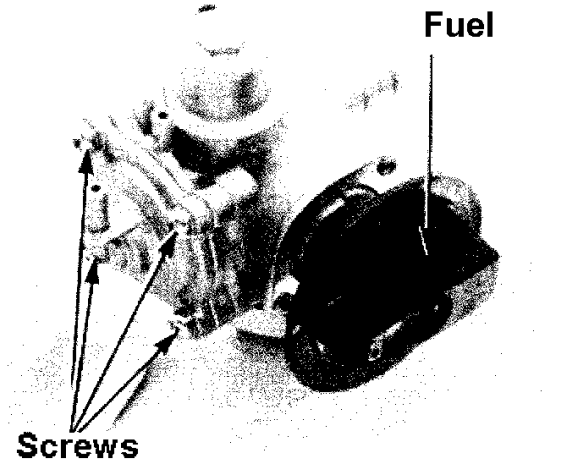

Remove the seven bolts for the air cleaner case.

Disconnect the air cleaner drain tubes and remove the air cleaner.

### Attachment

Reverse the above procedure.

Make sure the air cleaner drain tube and main wire harness are correctly attached.

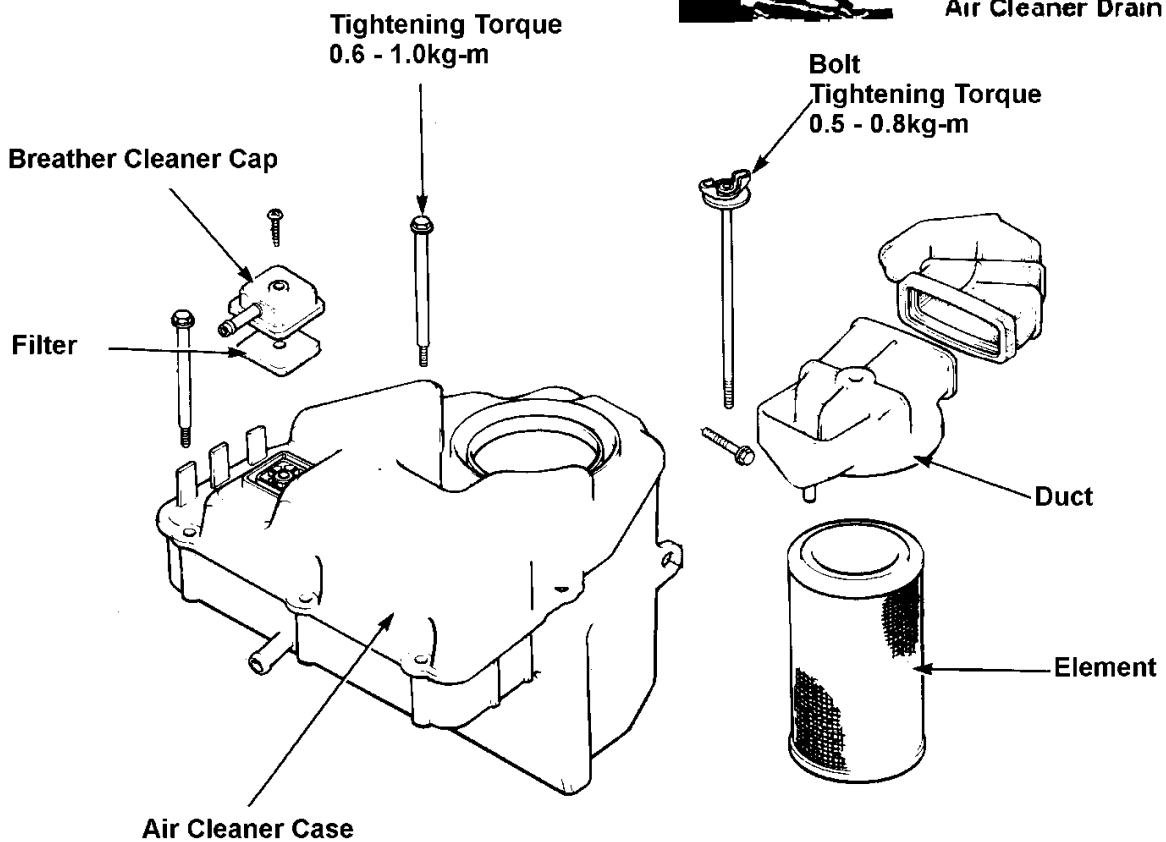
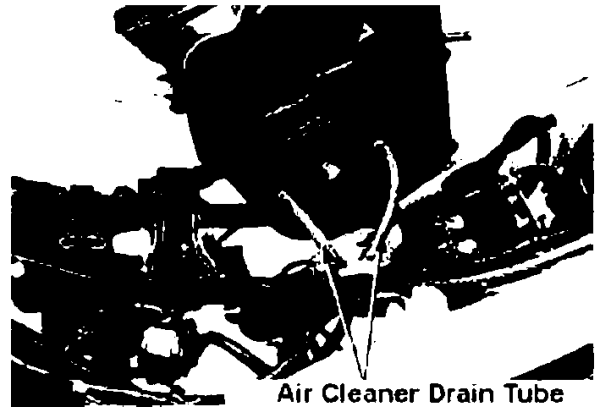
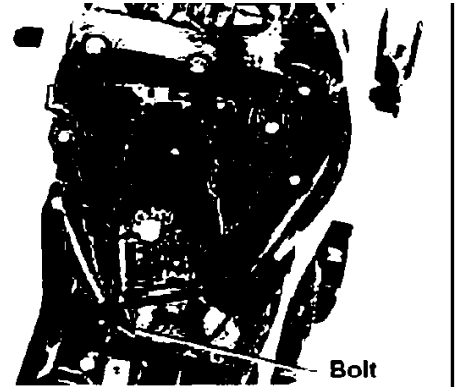

- Carburettor

### Removal

Remove the fuel tank (4-3) and the air cleaner (4-6).

Loosen the 4 screws on the carburetor insulator band (4 on cylinder side).

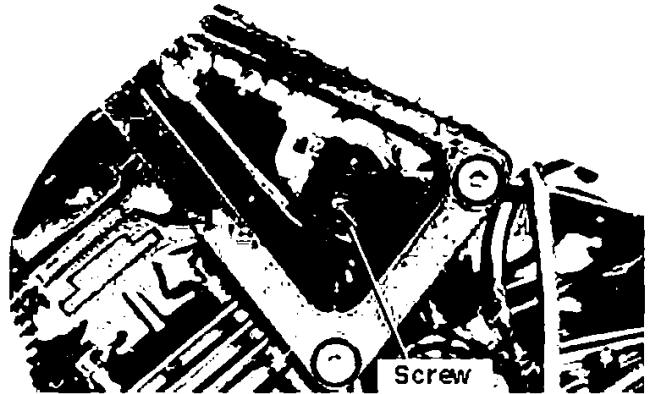

Disconnect the throttle and choke cables and remove carburetor Assy.

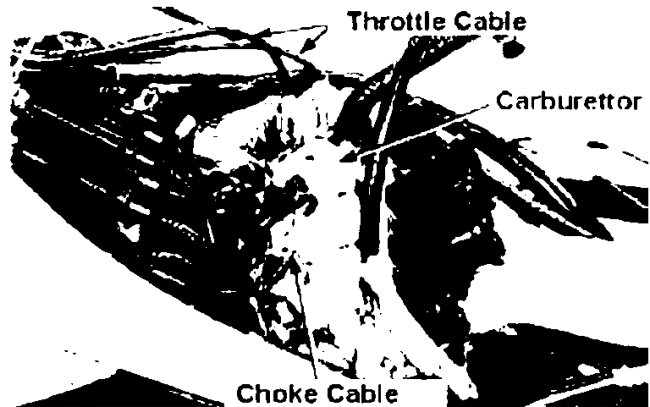

### Disassembly

Disassembly of the vacuum chamber and the float chamber are possible without removing the carburettor.

Remove the insulator from the carburettor.

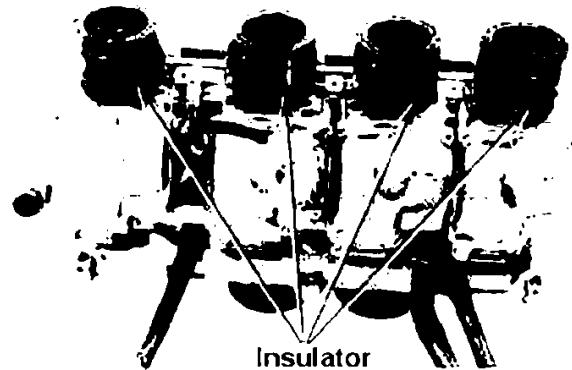

Rotate the throttle stop screw and set so as to have all carburetors' bypass holes visible.

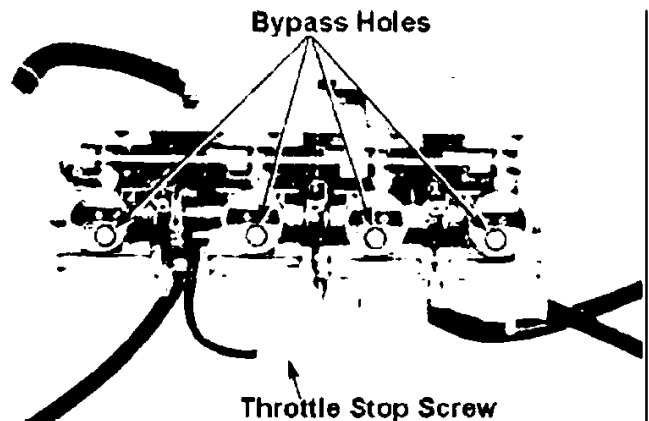



Loosen the bolts on bistarter arms and remove the bistarter arm shaft and spring.

Remove the bistarter arms.

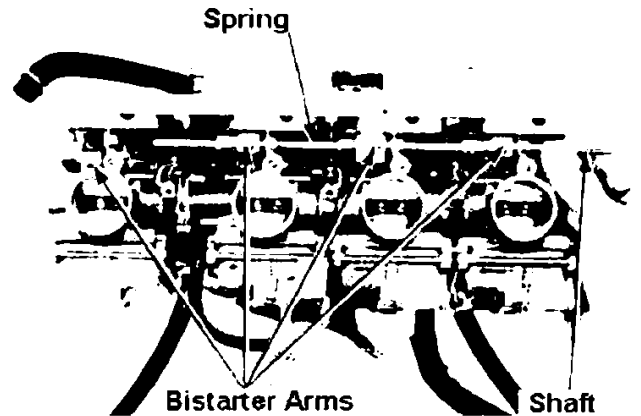

Raise the catch (projection).  
Remove the screw to remove the rear bracket.

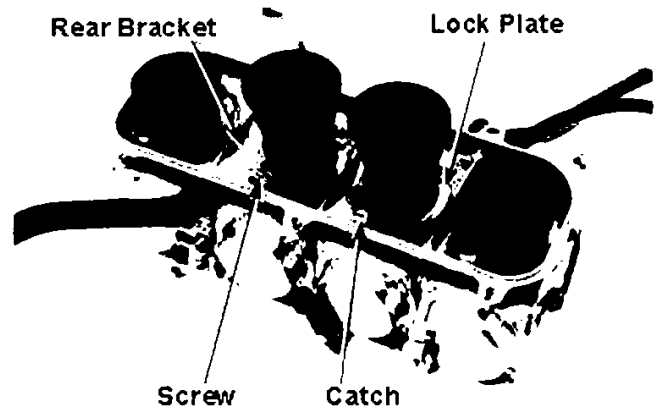

Remove the eight dowels.  
Inspect the air funnels for damage.

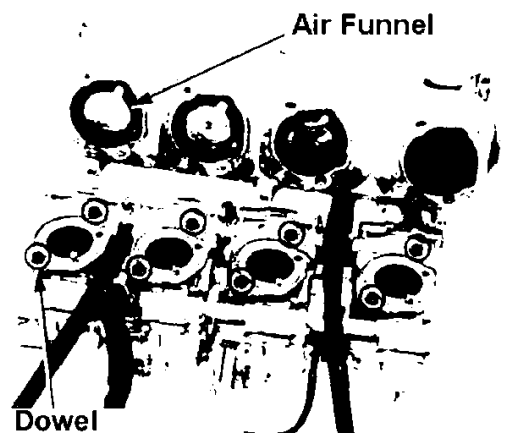

Remove the eight screws and remove the front bracket.

- The two carburetors thrust springs and three synchro adjust springs come off at the same time. Make sure not to lose them.
- Separate horizontally in order to avoid damaging the fuel and air joint pipe.

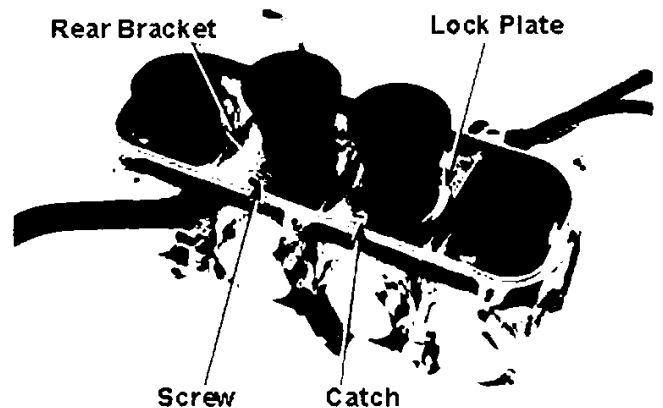

Remove the vacuum chamber cover.

Vacuum Chamber Cover



Remove the spring, diaphragm and the vacuum piston.

Ensure that there is smooth movement of the piston in the chamber.

Spring

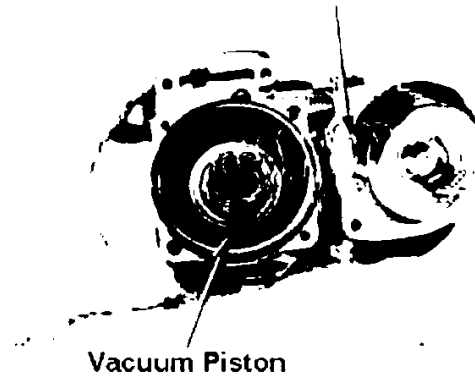

Push the jet needle holder in and rotate 45° to the left.

Remove the needle holder, spring, jet needle and washer from piston.



Jet Needle Holder

Inspect the needle head for wear, twist or damage.

Inspect the diaphragm for damage.

Inspect the vacuum piston for wear, damage.

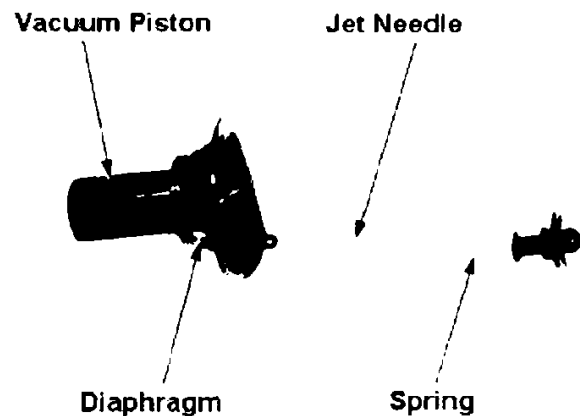

Remove the float chamber.

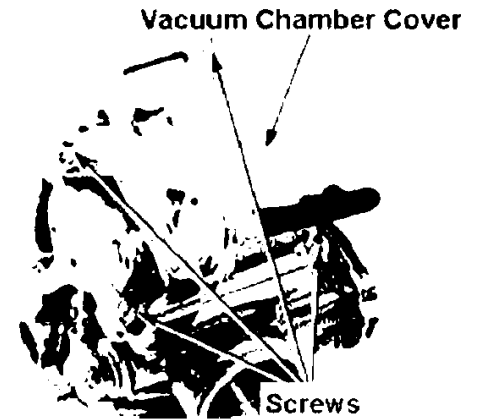

Pull out the float pin and remove the float and the float valve.

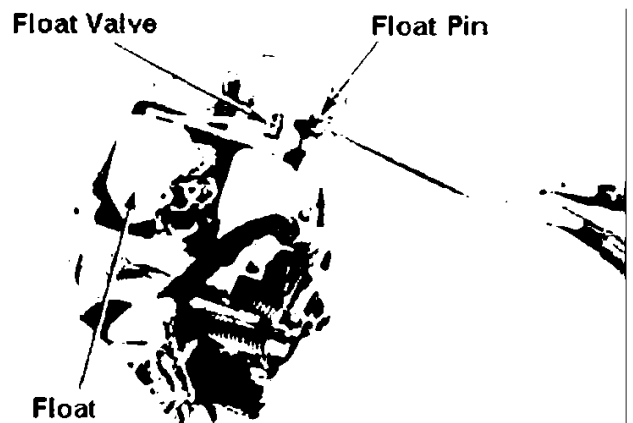

Inspect the float.

Inspect the float valve and a valve seat for damage, clogging.

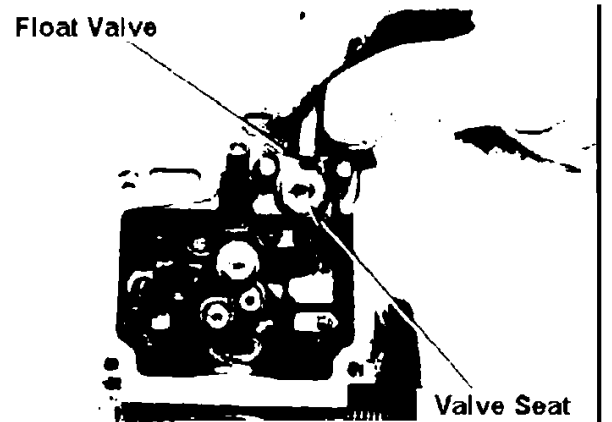

Inspect the contact surface between the valve and the seat for wear.

Remove the main jet, needle jet holder, slow jet and the valve seats.

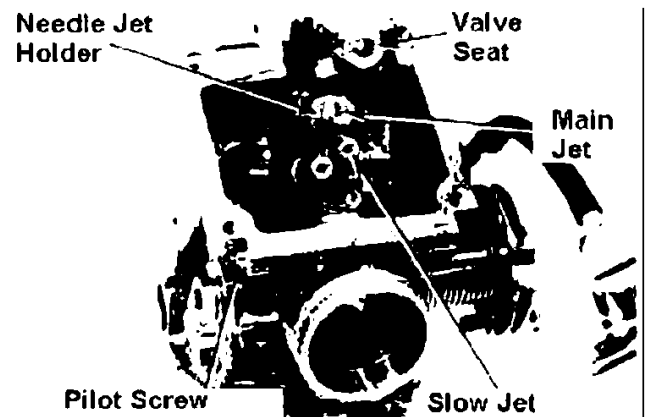

Record the number of turns on the pilot screw to fully-tighten. Then remove the screw.

Do not overtighten the pilot screw.  
May cause damage on the seats.

Clean the jets with clean fuel.

Loosen the bistarter valve nut and remove the valve spring and the valve.

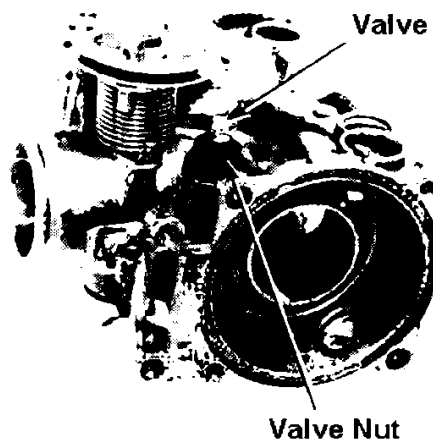

Inspect the bistarter valve for damage and wear.

Do the same for the valve spring.

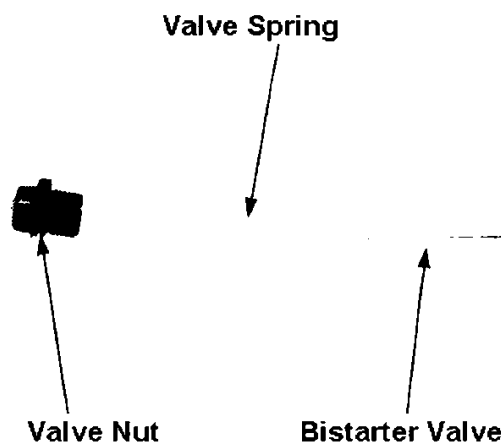

Clean the carburetor body air passage by using the compressed air.

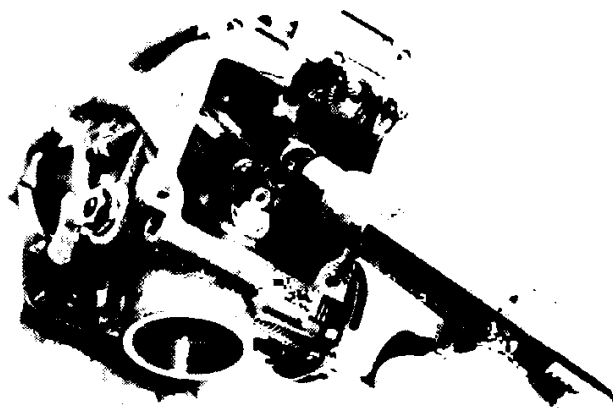

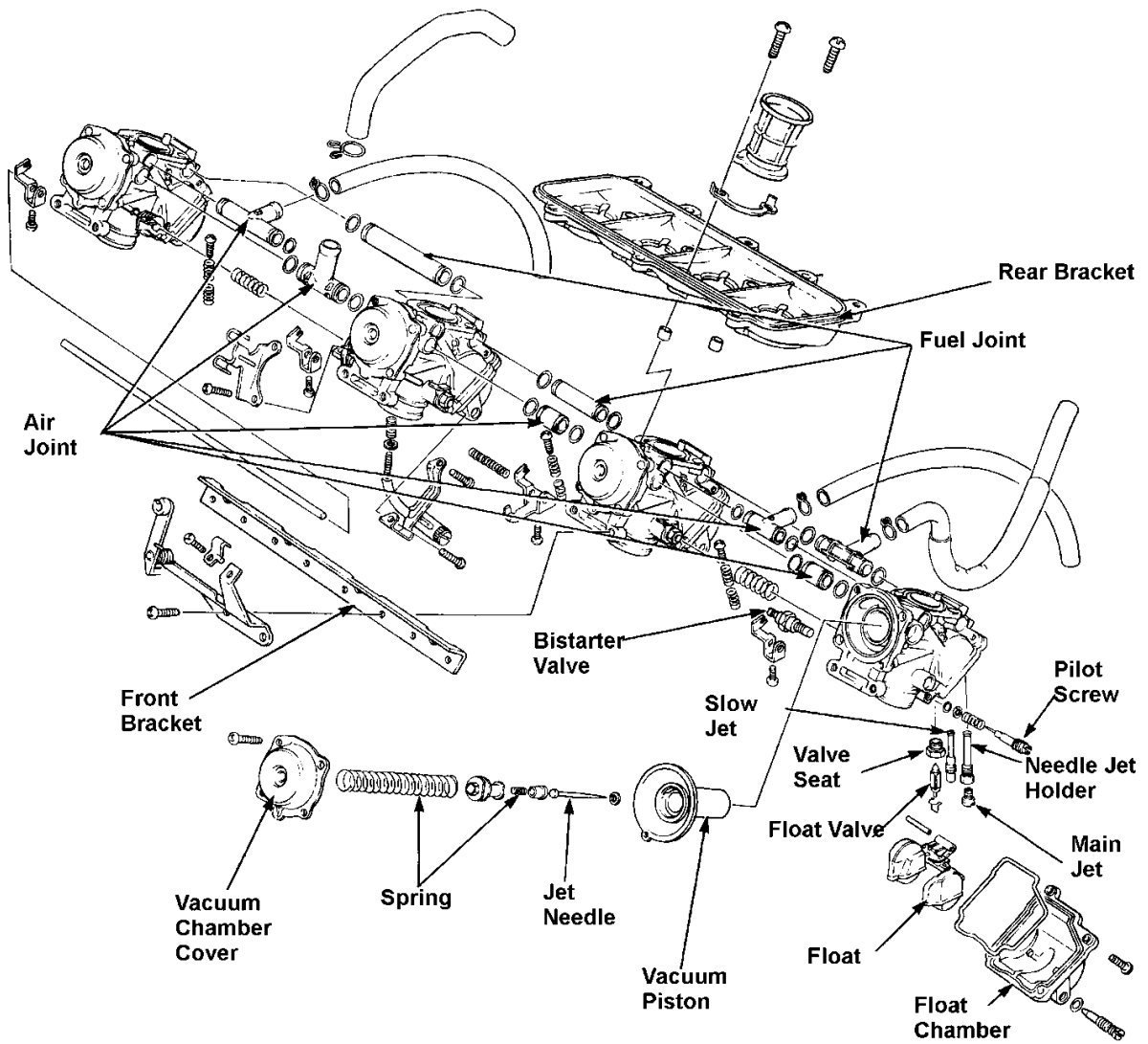

Attach the bistarter valve, valve springs and valve nuts.

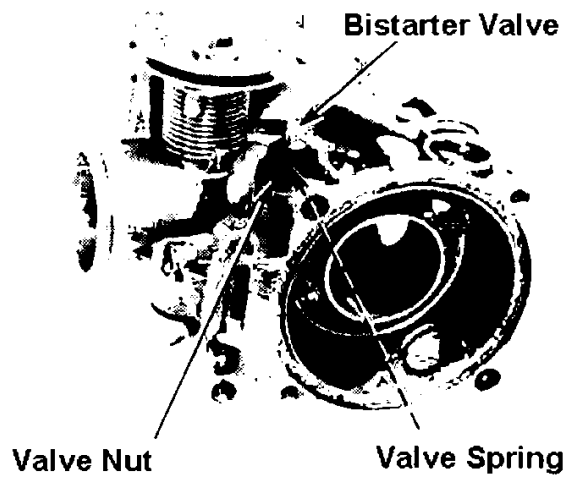

Attach the needle jet holder, main jet, slowjet, valve sheet and the pilot screw to the carburettor body.

Fully tighten the pilot screw and wind back number of turns recorded upon disassembly. Do not tighten hard or it may damage the seat surface.

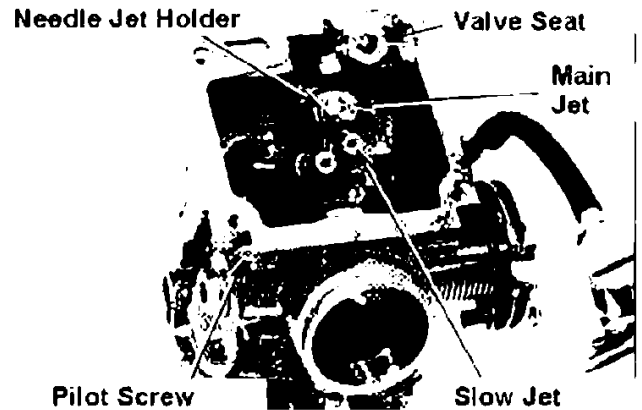

Attach the float and the float valve with the float pin to the carburetor body.

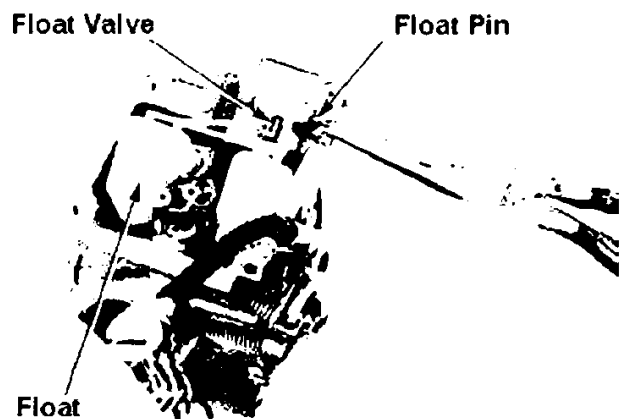

### Fuel Level

Set the float chamber attachment surface vertically.

Tilt the carburettor to forward 30° (the float valve and the float arm contact) and measure the fuel level.

Standard level : 7mm.

Bend the lip of the float arm to adjust the level.

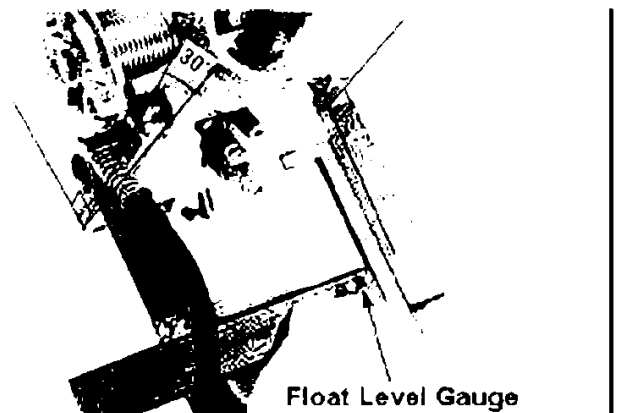

### Common Tool

Float level gauge

Use the gauge at a position for main jet and set perpendicular to the float chamber attachment surface.

Inspect the O-ring for wear.

Apply oil on the O-ring and attach the float chamber.

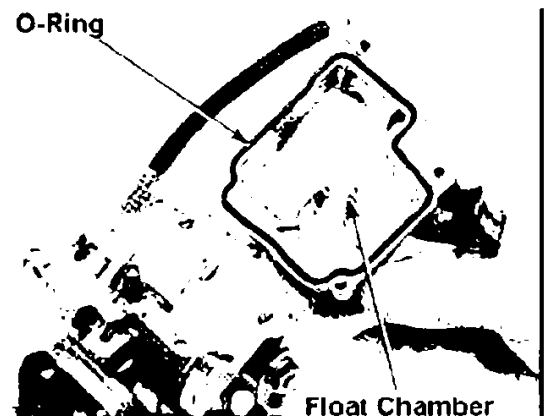

Tighten with four screws.

Tighten and attach the throttle stop screw holder to a carburettor body with 2 screws.



Attach the washer, jet needle and a spring to the vacuum piston. Push the jet needle holder in and rotate 45° to the right.

Jet Needle Holder

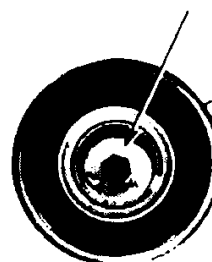

Push the bottom of the vacuum piston towards vacuum chamber side and make it nearly full open position.

Firmly fit the rib of the diaphragm to the slit on the body.

Attach the spring and align the hole on the diaphragm and the slit on the cover to attach the cover.

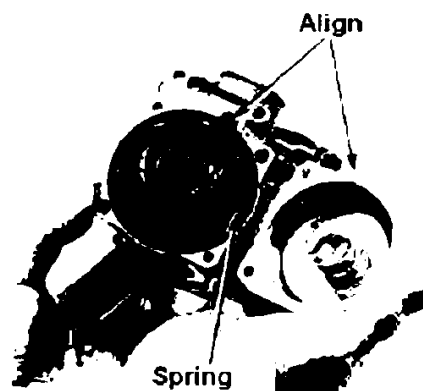

The cover should not catch the diaphragm.

Tighten the 4 screws.



Attach new O-rings to the air joint valves, fuel joint valves.

Apply small amount of oil to the O-rings.

Connect the carburetors via thrust springs, air and fuel joints.

Attach the synchronizing spring.

Set the springs, joints and tubes in accordance with the diagram.

Temporarily fix the front bracket with screws.

Place the carburetor on a flat plate with the rear side facing down.

Apply equal pressure on the carburetors and temporarily tighten the screws in the sequence shown.

Repeat this procedure 2~3 times to fix.

Fix the bistarter arm together.

Attach the dowel.

Set joints and tubes correctly as shown in the figure.

Attach the rear bracket.

Attach the new locking plates and temporarily fix with screws.

Place the carburettor on flat plate facing the front side down.

Apply equal pressure on the carburetors and tighten the screws in the sequence shown.

Repeat the procedure 2~3 times to fix.

Firmly tighten the screws for the front bracket.

Lock the screws by bending the catch of the locking plate.

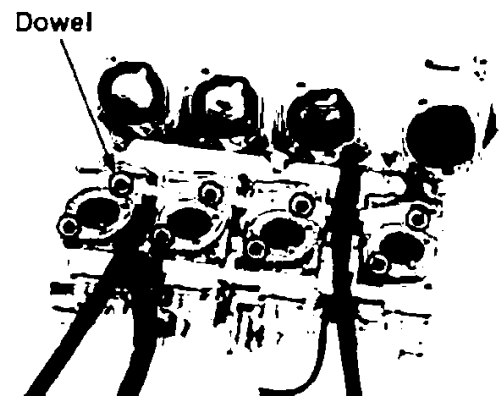
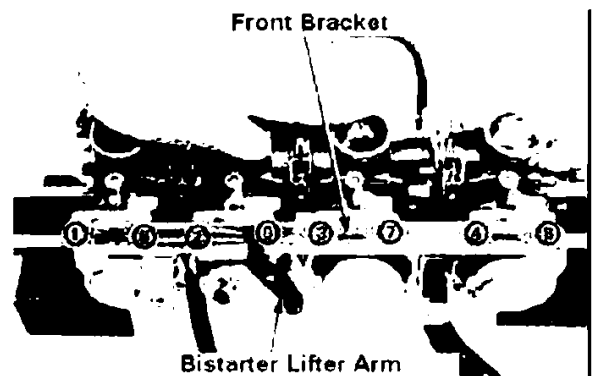
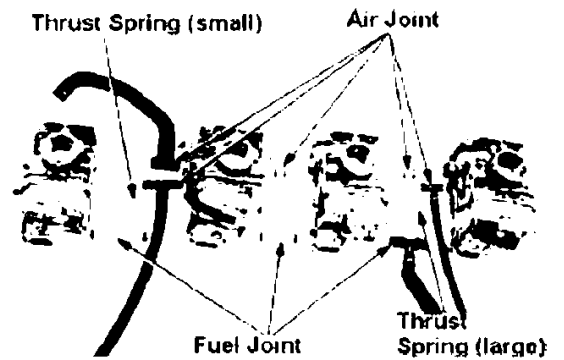



Attach the bistarter arms to bistarter valves.

Attach the spring and the arm shaft.

Fix the bistarter arms to the shaft.  
Move the bistarter lifter arm and ensure the movement of the bistarter valves.

Inspect the throttle movement by following the procedure:

- Push the throttle linkage and open the throttle a bit and ensure the throttle returns smoothly.
- Open and close the throttle and ensure the smooth movement.

Rotate the synchronizing adjust screw and align all carburettor bypass holes and the position of the throttle valve.

Use No.3 carburettor as a reference.

Attach insulator to carburettor.

Set the insulator screws to the direction indicated by arrow symbols.

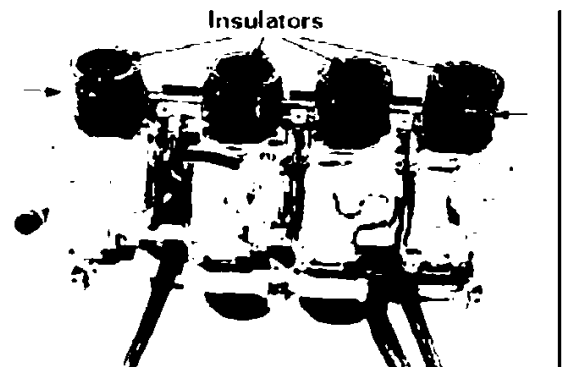
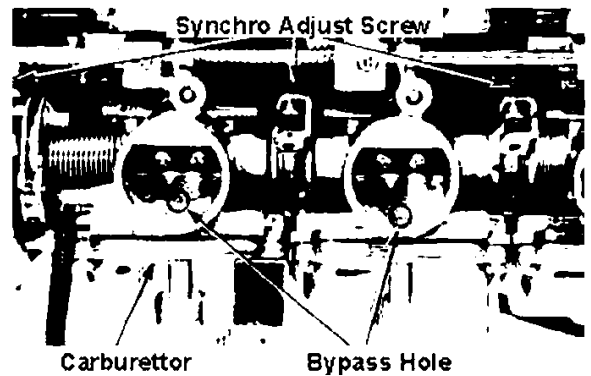
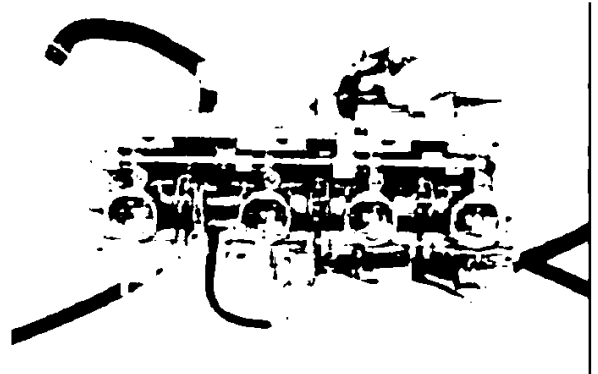
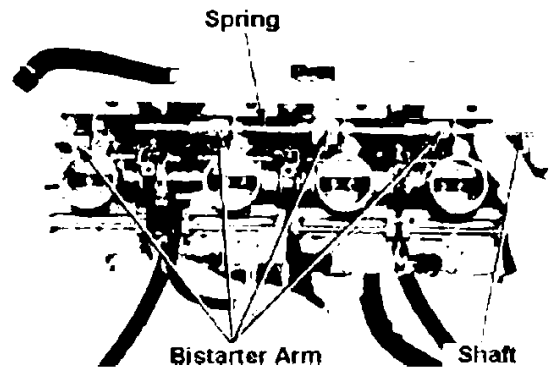

## Attachment

Connect the choke and throttle cables.

Attach the carburettor to the cylinder head.  
Tighten the insulator screw.  
Attach the air cleaner case. (4-7)  
Attach the fuel tank. (4-3)

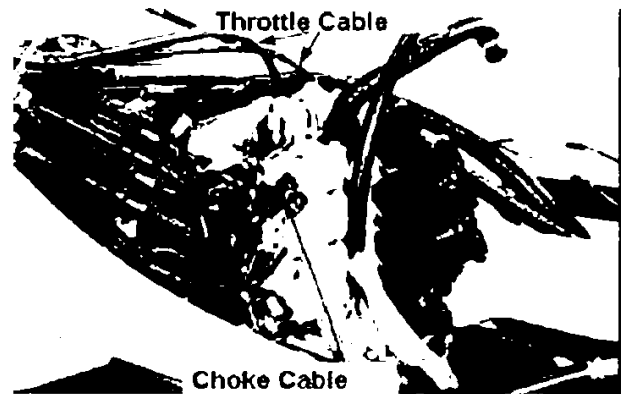

After attaching the above items, inspect/adjust the following items.

- Pilot screw                      Idling speed (2-11).
- Throttle grip (2-17)          Carburetor synchronizing (4-19)

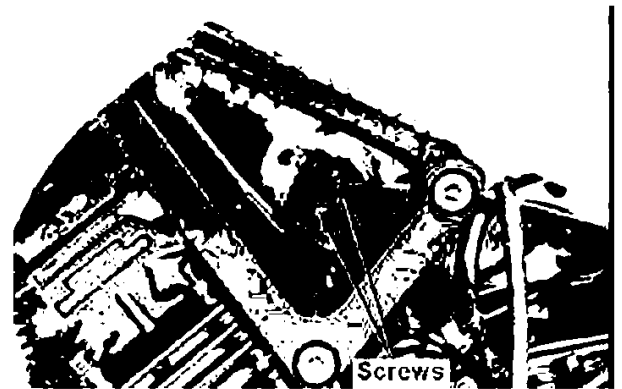

## Pilot screw adjustment

Screw the pilot screw in until it stops and rewind to the number of turns recorded when disassembling.

If the body or the pilot screw has been replaced, wind back to the standard setting.

**Standard rounds : 2 and ½ turns.**

Do not overtighten the pilot screw.  
It may damage the seat surface.

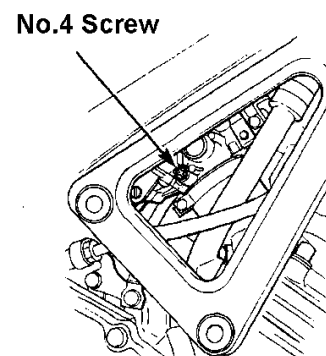
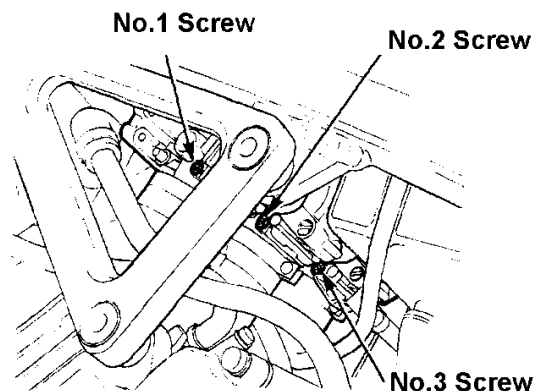

## Carburetor Synchronizing

Conduct after warming up.

Start the engine. Fix the vacuum tube on the fuel auto cock with the tube clip so as to apply vacuum to auto cock. Then stop the engine.

This procedure is not necessary if the vacuum pump is available. After removing the tank, apply negative pressure on the vacuum tube with the pump.

Remove the fuel tank with the tube attached and locate behind the vehicle.  
Remove plugs/washers from each cylinder head. (Remove vacuum tube for #3 cylinder).  
Attach the vacuum gauge adapter to each plug holes.  
Connect the rubber tubes on the vacuum gauge to the adapter. (Directly connect the rubber tube to #3 cylinder).

Start the engine and set to specific idling rpm.

**Idling rpm : 1500±100rpm.**

Measure the vacuum pressure difference between the cylinders.

**Vacuum pressure difference : 40mm Hg**

Measuring tool : Vacuum gauge 07404-0020000

If the number exceeds the above limit, adjust in the following way.

1. Confirm the individual carburetors' pilot screws are set to standard setting.
2. Adjust the synchronization by rotating the adjusting screw.

**#3 Carburetor is the standard.**

After adjustment re-check the synchronizing and adjust the idling.  
Reverse the procedure for re-assembly.

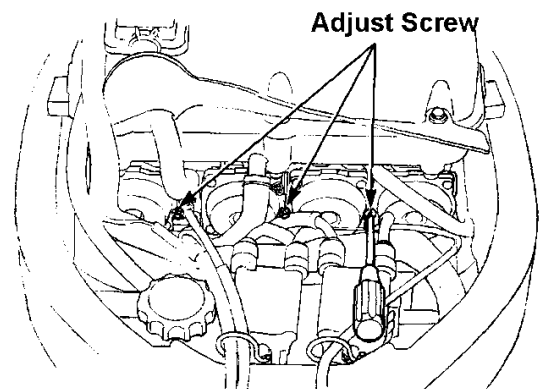
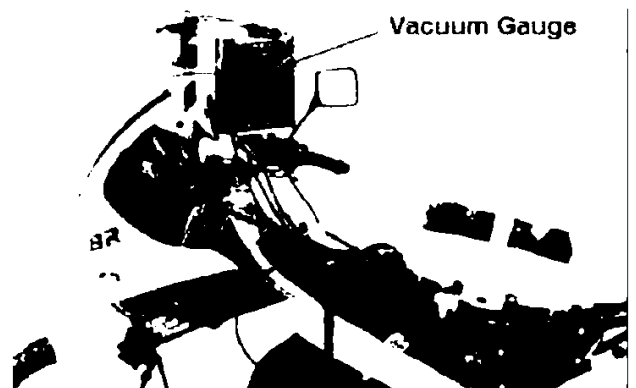
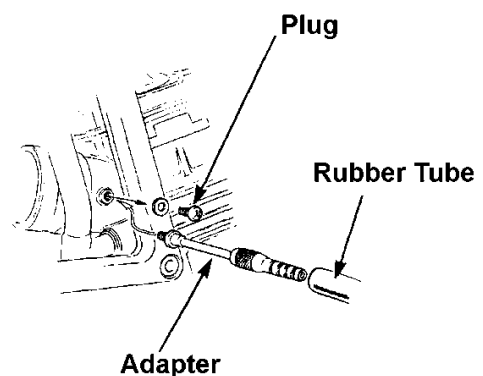
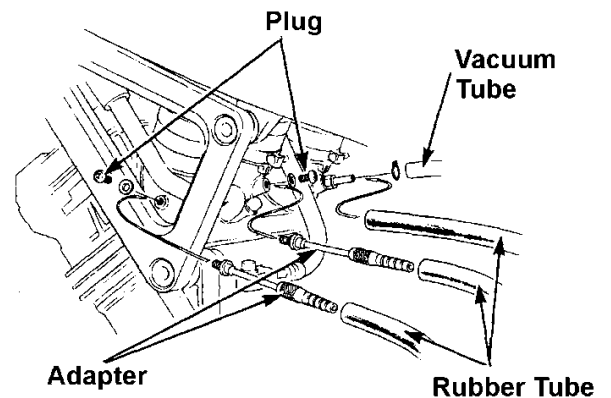

• Assembly

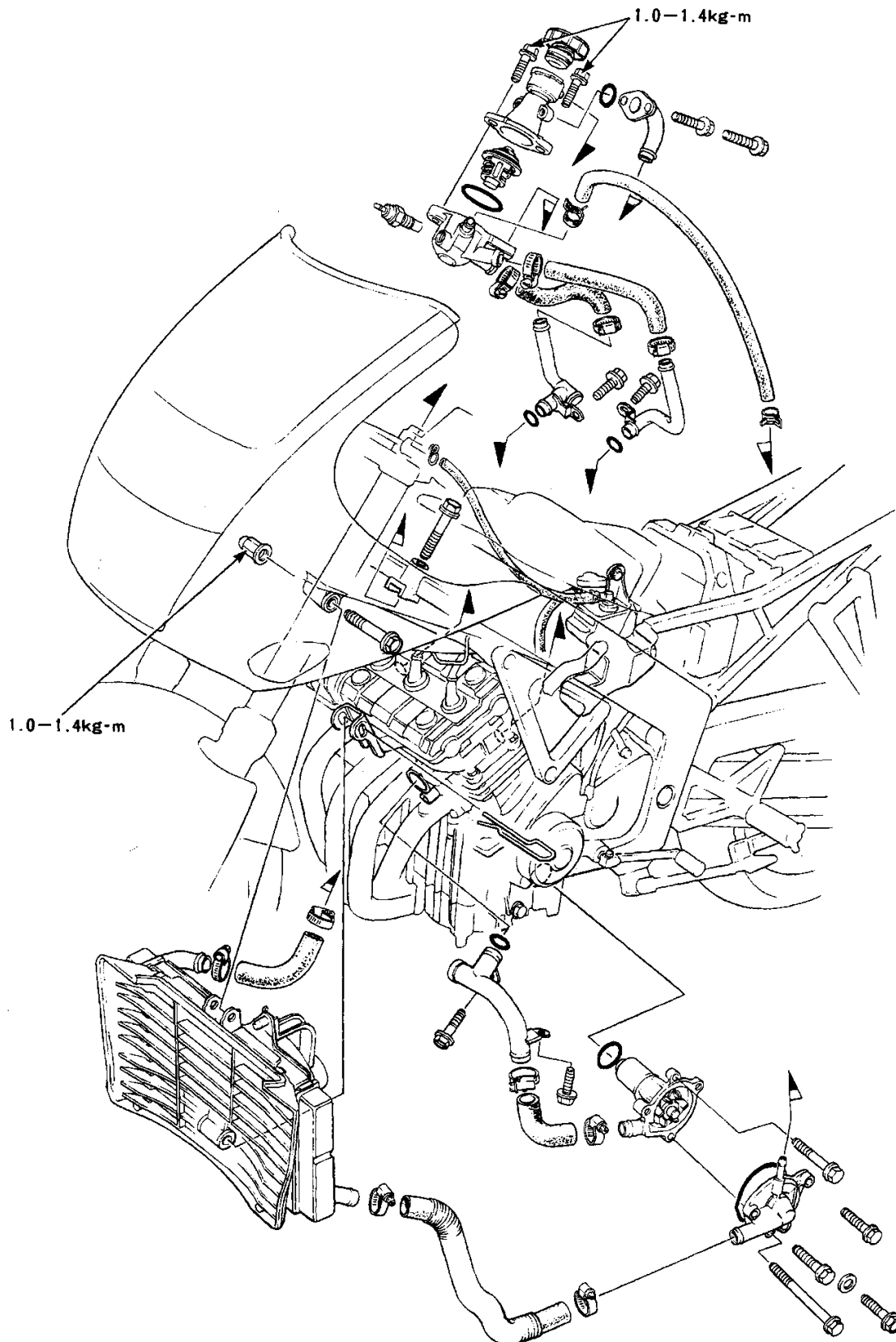

Assembly	5 - 0	Thermostat	5 - 6
Maintenance Information	5 - 1	Thermal Sensor	5 - 8
Troubleshooting	5 - 1	Water Pump	5 - 9
Radiator	5 - 3	Reservoir Tank	5 - 11

### • Maintenance Information

#### General Caution

- Conduct the maintenance while the engine is cool.
- Do not open the radiator cap when it is hot.
- All of the cooling system maintenance can be conducted on the vehicle.
- Refill of the radiator fluid should be done through the reservoir tank. Do not remove the radiator cap except for radiator fluid refill / drain purposes.
- Radiator coolant may damage the painted surface. Wash off with water immediately.
- After the work, inspect all joints / seals for water leak by using a radiator cap tester.

Maintenance Standard		Standard	Limitation
Radiator Cap	Valve Opening Press	0.75 – 1.05kg/cm <sup>2</sup>	≤0.75kg/cm <sup>2</sup> or ≥1.05kg/cm <sup>2</sup> → Replace
Thermostat Valve Opening Temperature	Initial Opening	80 – 84°C	-
	Full Open	95°C	-
	Full Open Lift	8mm or more	-
Cooling Water Capacity		Total Approx. 1.300cc	Radiator Side Approx 1.100cc Reservoir Tanked 200cc

### Tightening Torque

Radiator Upper Stay	1.0 – 1.4kg-m
Thermostat Cover	1.0 – 1.4kg-m
Radiator Grill	0.8 – 1.2kg-m

### Troubleshooting

Too High water temperature	Water Leak
• Water Temp indicator or the thermal sensor failure	• Mechanical seal failure
• Radiator Cap failure	• Worn out / damaged water hose
• Thermostat failure	• Worn out / loose O rings
• Radiator liquid level too low	
• Clogged water hose / jacket	<b>Water temp too low or slow rise</b>
• Bent Pin	• Temp indicator / thermal sensor failure
• Clogged radiator	• Thermal sensor failure
• Water pump failure	• Thermostat Failure

**Radiator Liquid Specific Gravity**

Density % Temp	0	5	10	15	20	25	30	35	40	45	50
5	1.009	1.009	1.008	1.008	1.007	1.006	1.005	1.003	1.001	0.999	0.997
10	1.018	1.017	1.017	1.016	1.015	1.014	1.013	1.001	1.009	1.007	1.005
15	1.028	1.027	1.026	1.025	1.024	1.022	1.020	1.018	1.016	1.014	1.012
20	1.036	1.035	1.034	1.033	1.031	1.029	1.027	1.025	1.023	1.021	1.019
25	1.045	1.044	1.043	1.042	1.040	1.038	1.036	1.034	1.031	1.028	1.025
<b>*30</b>	<b>1.053</b>	<b>1.052</b>	<b>1.051</b>	<b>1.049</b>	<b>1.047</b>	<b>1.045</b>	<b>1.043</b>	<b>1.041</b>	<b>1.038</b>	<b>1.035</b>	<b>1.032</b>
35	1.063	1.062	1.060	1.058	1.056	1.054	1.052	1.049	1.046	1.043	1.040
40	1.072	1.070	1.068	1.066	1.064	1.062	1.059	1.056	1.053	1.050	1.047
45	1.080	1.078	1.076	1.074	1.072	1.069	1.066	1.063	1.060	1.057	1.054
50	1.086	1.084	1.082	1.080	1.077	1.074	1.071	1.068	1.065	1.062	1.059
55	1.095	1.093	1.091	1.088	1.085	1.082	1.079	1.076	1.073	1.070	1.067
60	1.100	1.098	1.095	1.092	1.089	1.086	1.083	1.080	1.077	1.074	1.071

\* Standard

**Radiator liquid mixture table (anti-corrosion / ice-free)**

Minimum Temp	Mixture	Honda Ultra Radiator Liquid	Purified Water
-9c	20%	260cc	1.040cc
<b>-16c</b>	<b>30%</b>	<b>390cc</b>	<b>910cc</b>
-25c	40%	520cc	780cc
-37c	50%	650cc	650cc
-44.5c	55%	715cc	585cc

**General caution for the radiator liquid**

- Use Honda Ultra radiator liquid or equivalent
- Do not mix with the other product
- Toxic. Do not drink
- Apply 5°C allowance to the minimum temperature

- Radiator

### Inspection of radiator hoses

Remove the side cowl (13-4)  
Remove two bolts and detach the radiator grill.

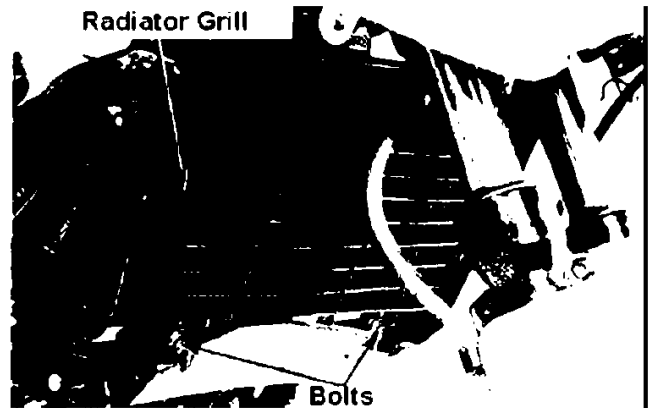

Inspect the hose/clamps for damage/wear.  
Check the radiator core for clogging and bending of the fins.

Adjust / replace the radiator if the clogging of the radiator core exceeds 20% of Total heat radiation area.

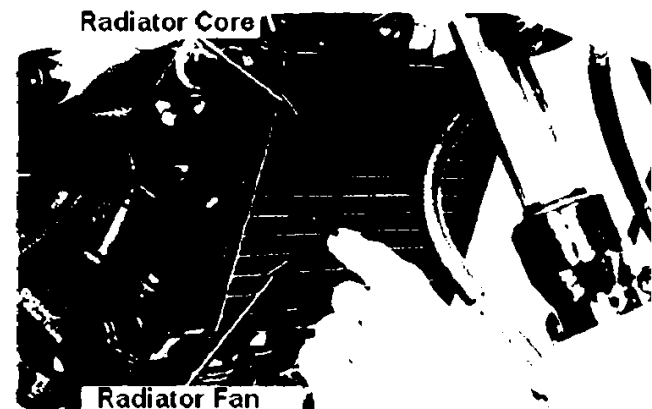

Adjust the bent fins with a screwdriver.

### Removal

Remove the drain bolt and drain the radiator liquid in the cylinders.

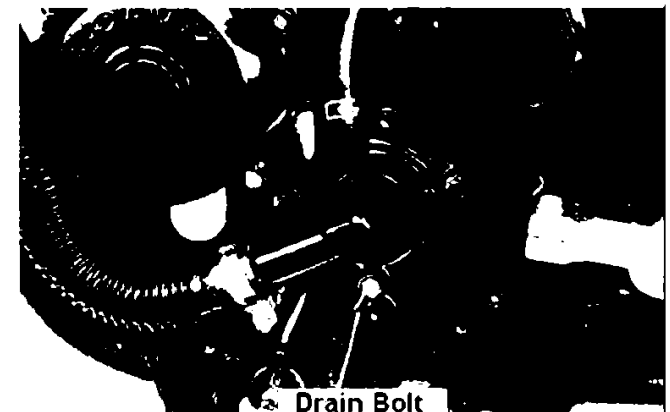

Remove the side cowl. (13-4)  
Remove the fuel tank. (4-3)  
Remove the #1, 4 ignition coil  
Attachment bolts and slide.  
Remove the radiator fan motor coupler.

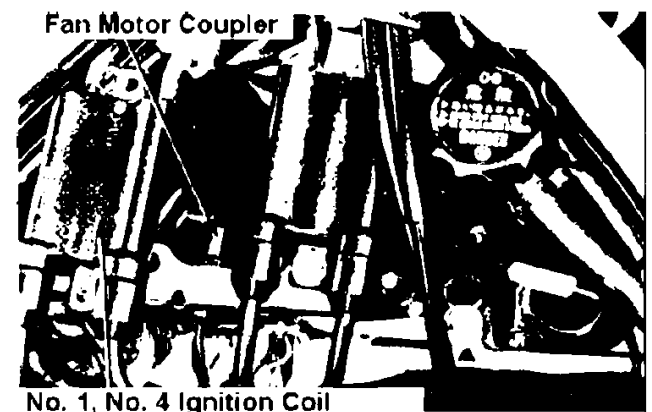

Remove the radiator attachment bolt.  
Remove the cooling fan switch wire connector.

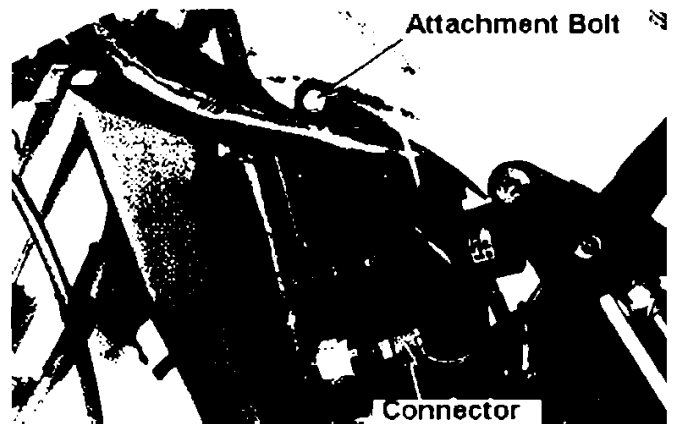

Remove the radiator set pin.  
Remove the lower radiator hose.

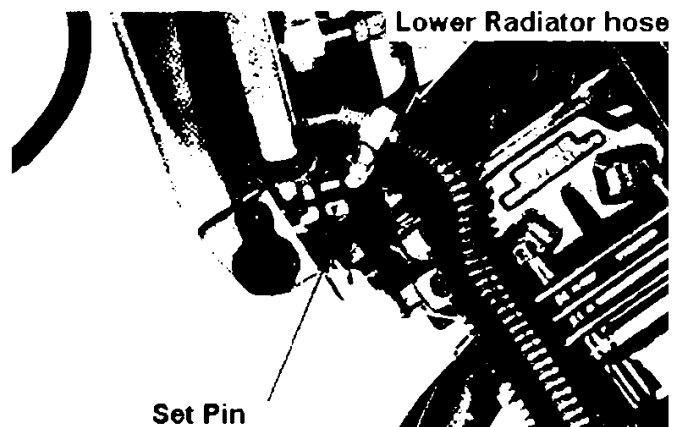

Pull the radiator forward.  
Disconnect the upper radiator hose and  
remove the radiator.

Do not damage radiator fins.

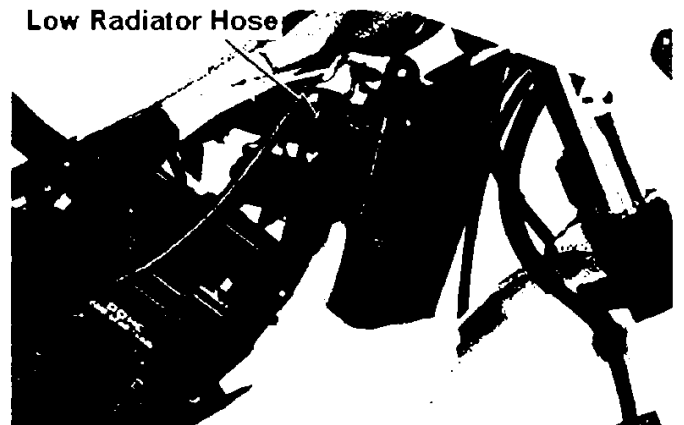

### Disassembly

Remove the two bolts and detach the  
radiator grill.

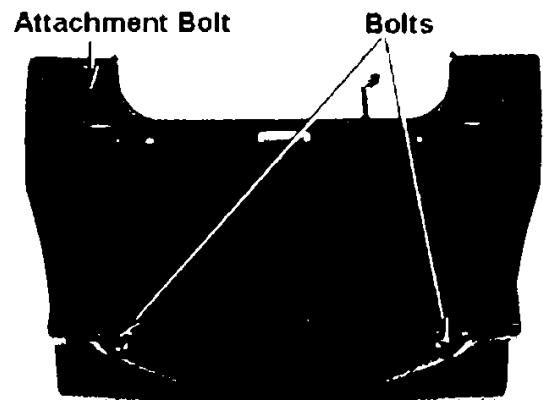



Remove the three bolts behind the radiator and detach the fan shroud and the fan motor at the ASSY.

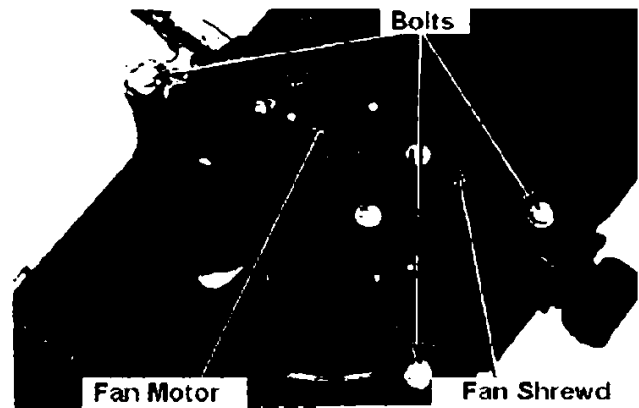

Remove nuts and remove the fan.

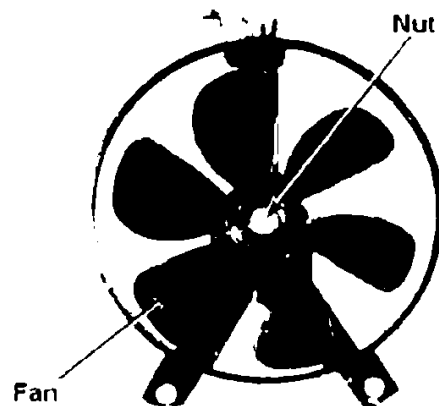

Detach the wire from the clamp. Remove three screws and detach the motor from fan shroud.

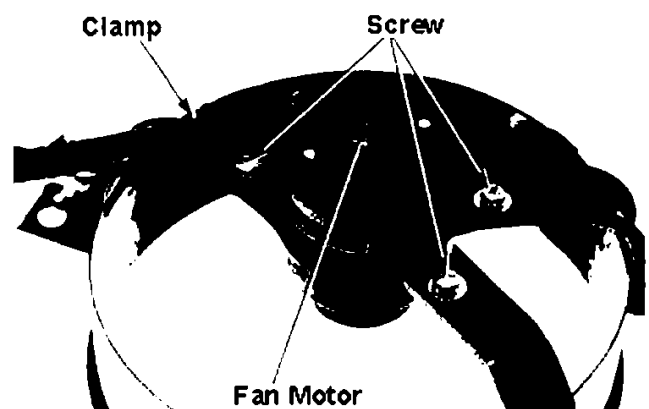

### Assembly

Inspect all parts for damage. Reverse the disassembly procedure for the assembly.

Align the fan motor axis and the slit on the fan when assembling the fan.

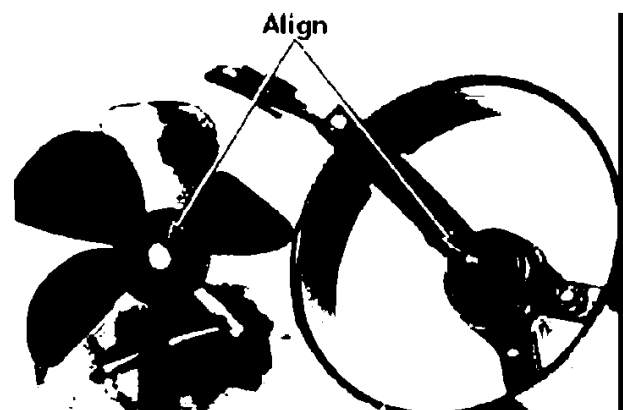

### Attachment

Reverse the detachment procedure.  
Tightening torque.  
Radiator upper stay: 1.0 ~ 1.4kg m  
Radiator grill : 0.8 ~ 1.2kg m  
Fill the radiator liquid. (2-19)  
Apply pressure to the radiator and  
inspect for water leak.

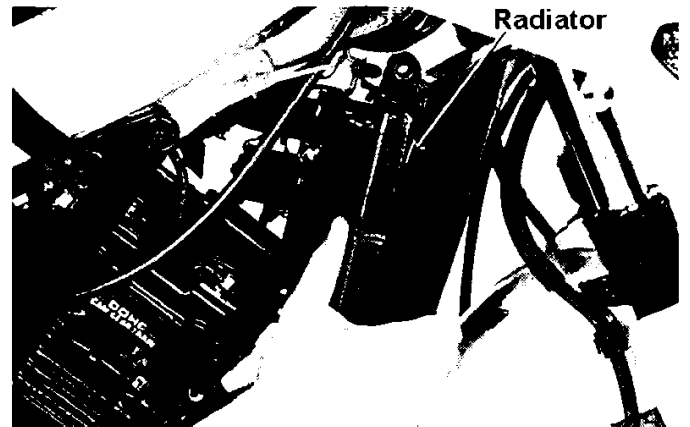

### Radiator cap inspection

Inspect the cap with a radiator cap tester.  
It should sustain 6 sec for standard pressure.

- Apply water on the seal surface of the cap when attaching the tester

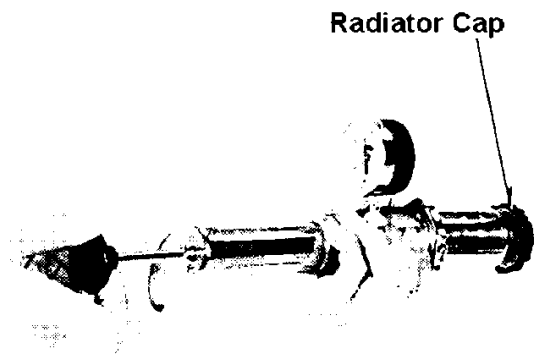

Radiator cap valve opening pressure: 0.9 kg/cm<sup>2</sup>

### Radiator pressurization test

Apply standard pressure with the tester.  
Should sustain for 6 sec.  
Standard pressure: 0.75 ~ 1.05kg/cm<sup>2</sup>

Inspect the hoses, each joint, bottom of the water pump for water leak.

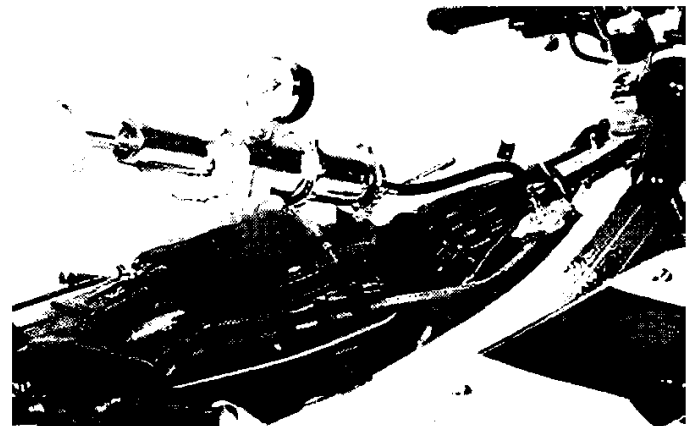

### Thermostat

### Removal

Remove the radiator cap.  
Drain radiator liquid (5-3)

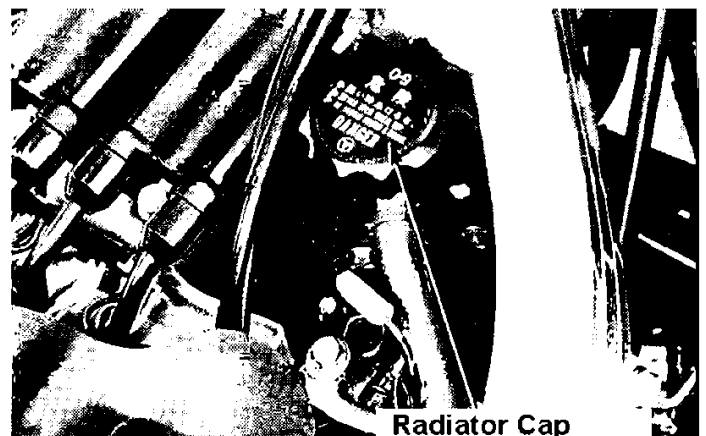

Remove two bolts and detach the pipe.

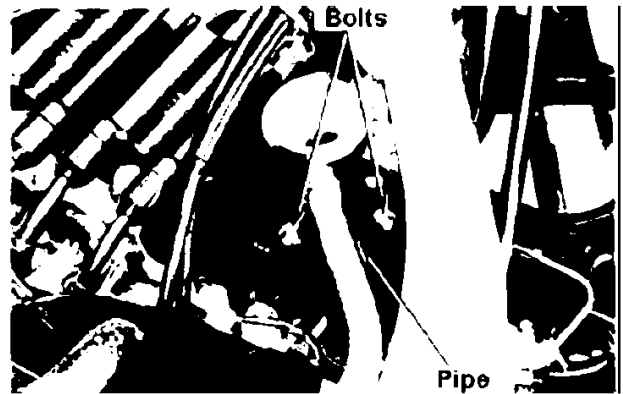

Remove O-Ring on the thermostat upper case.

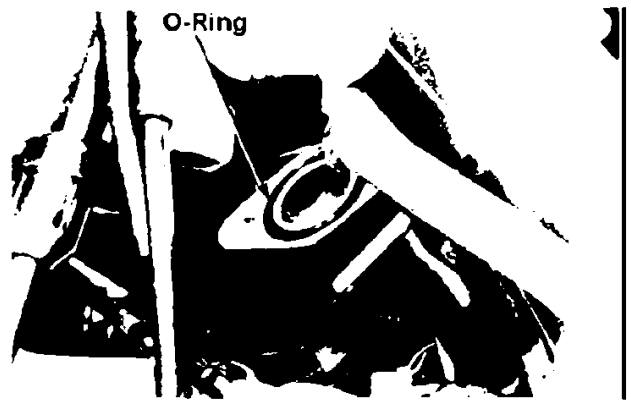

Disconnect the overflow tube.  
Remove two attachment bolts and detach the thermostat uppercase.

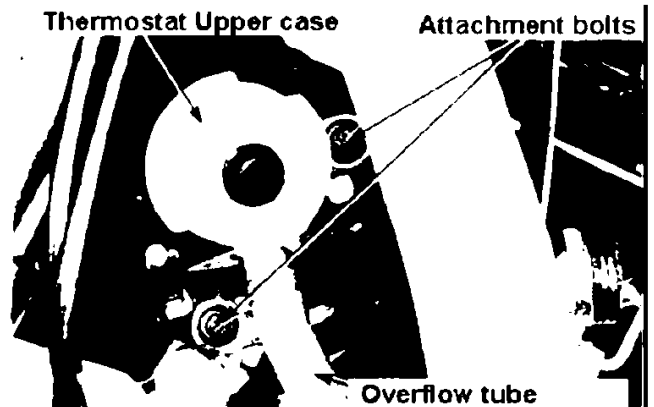

Remove the O-Ring and the thermostat.

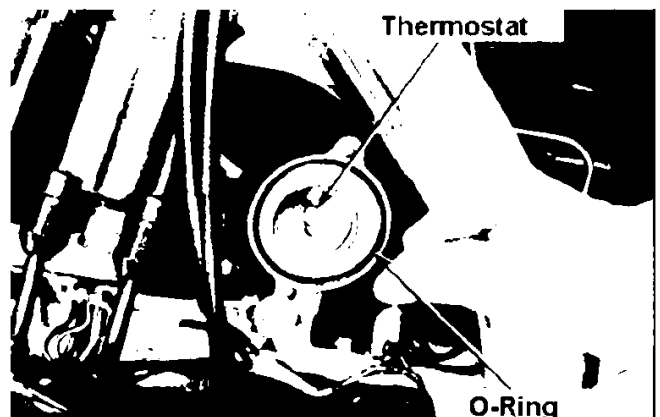

### Inspection

Put the thermostat into the testing container  
And gradually raise the temperature.

Thermostat specification

Initial opening temp	80~84c
Full open temp	95c
Full open lift	≥ 8mm

- The thermostat should not contact the container wall.
- Replace the thermostat if it is opened in room temperature.
- Measure the full open lift after applying 95°C for 5 min.

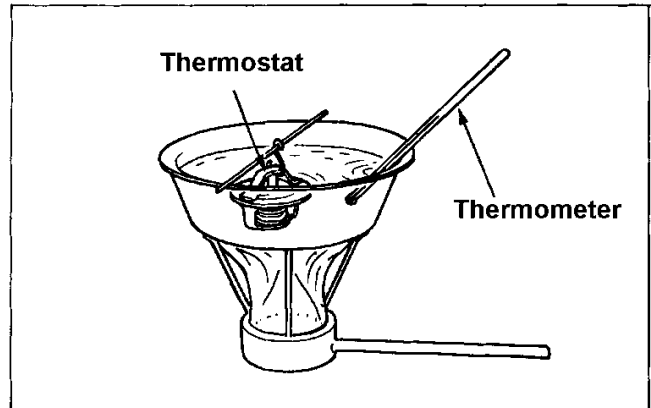

### Attachment

Attach an O-Ring to the thermostat body.  
Reverse the procedure for attachment.

Tightening torque.

Thermostat case: 1.0 ~ 1.4kg m

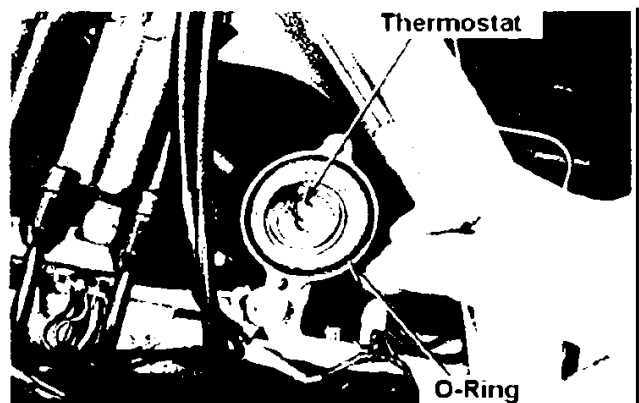

### Thermal Sensor

#### Detachment

Detach the wire from the thermal sensor.  
Remove the thermal sensor.

Place the thermal sensor in a test container filled with 50% radiator liquid.  
Gradually increase temperature and measure the resistance.

- The thermal sensor should not contact the container wall.

Thermal sensor specification.

Temp °C	50	80	120
Resistance Ω	153.9	51.9	16.1

Apply sealer to the screw of the thermal sensor  
and tighten to the thermostat case.

Connect the wires.

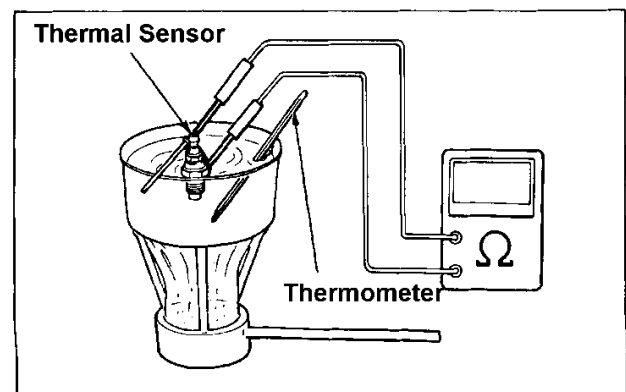
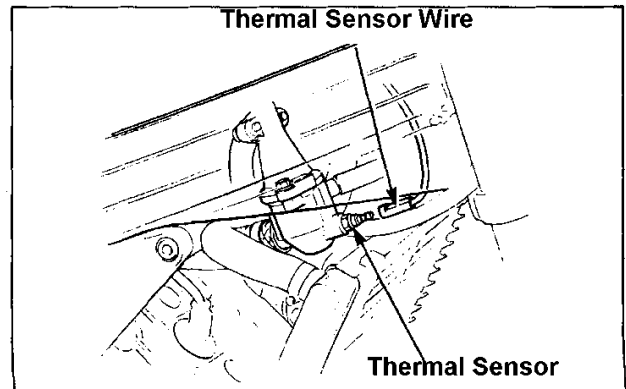

### Water Pump

#### Inspection of mechanical seals

Inspect the water pump inspection hole for radiator liquid leak. If leak was found, replace the water pump ASSY.

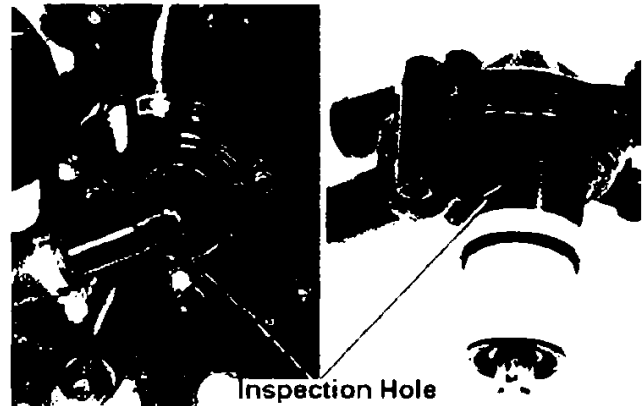

### Removal (Detachment)

Drain engine oil. (2 - 16)  
Drain radiator liquid. (5-3)  
Loosen the hose band and detach the radiator hose from the water pump cover. remove two attachment bolts and detach the Water pump ASSY.  
Remove O-Rings.

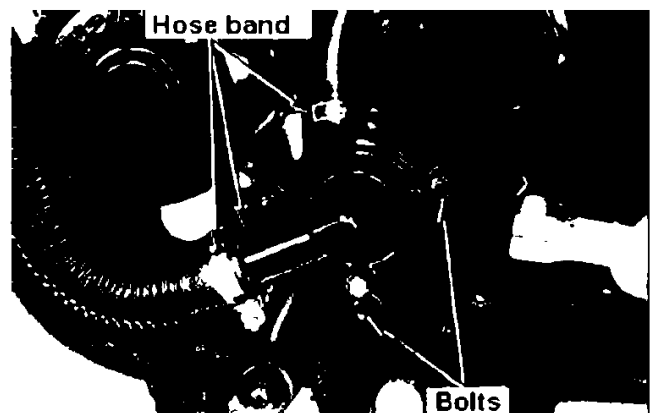

Remove the two bolts and separate the Water pump and its cover.

### Inspection

Inspect the pump for damage, replace as ASSY if damaged.

- Do not disassemble the water pump.
- Water pump replacement is considered to be ASSY replacement.

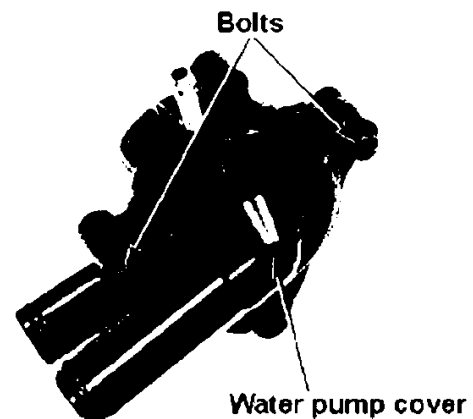

### Attachment

Attach O-Ring to the water pump cover.

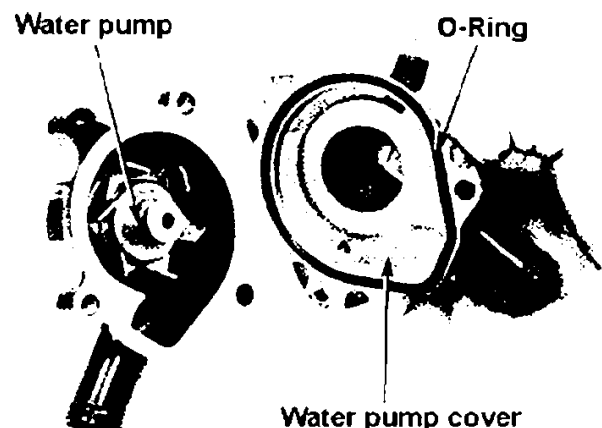

Attach cover to the pump and  
Tighten the two bolts.

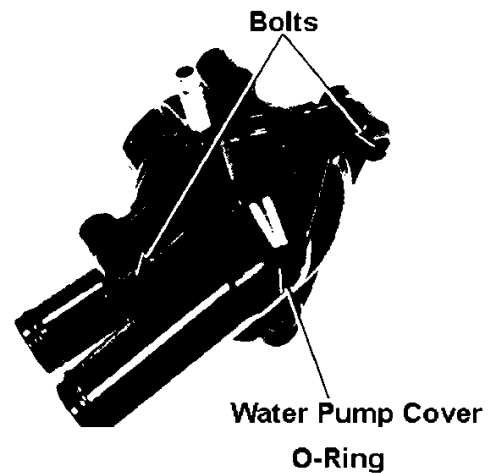

Attach the O-Ring to the water pump.

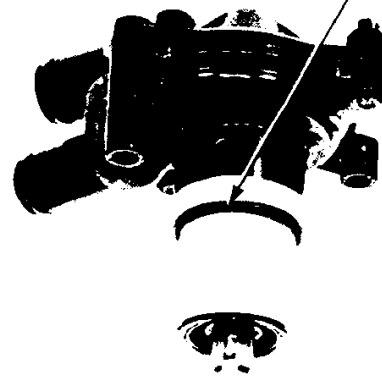

Align the oil pump shaft and the slit of  
the water pump shaft and attach the water  
pump ASSY to the crank case.

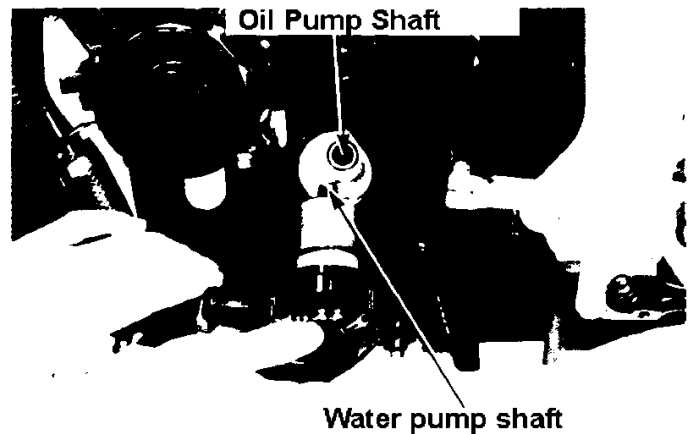

Tighten the two attachment bolts.  
Attach the radiator hose to the water  
pump cover and tighten the hose band.  
Fill the radiator liquid (2 – 19).  
Fill the engine oil (2 – 17)

Ensure there are no leaks after the work is  
completed.

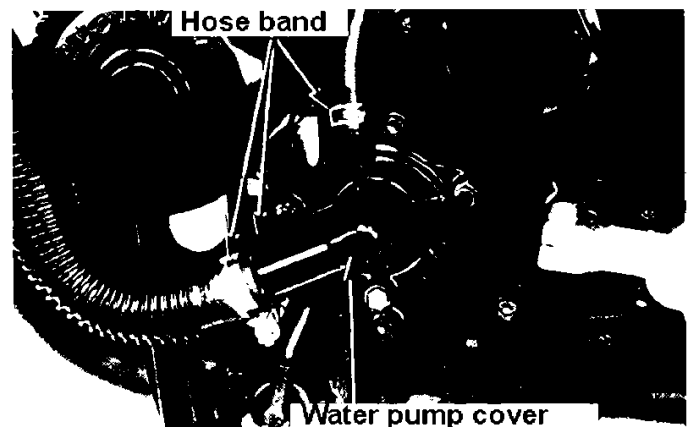

### Reservoir Tank

#### Detachment

Remove the seat side cover.  
Remove the fuel tank. (4-3)  
Disconnect the battery terminals and  
Remove the battery.  
Remove battery holder bolts.

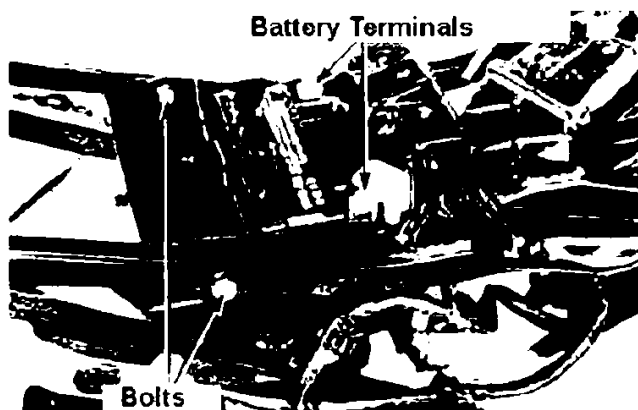

Tilt the battery holder backwards and  
Detach the spark units.  
Detach the dent part of the battery holder  
From the sub frame projection.

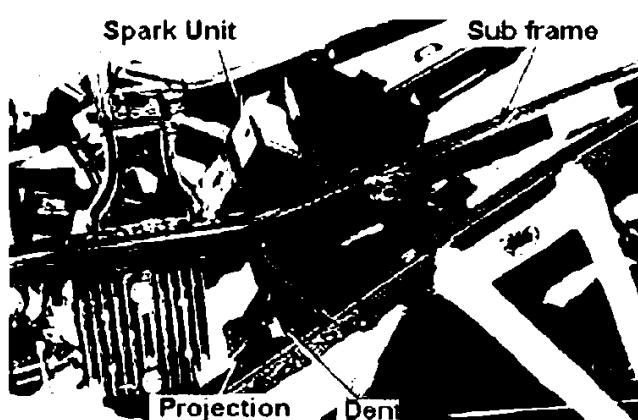

Remove the reservoir tank attachment bolt.

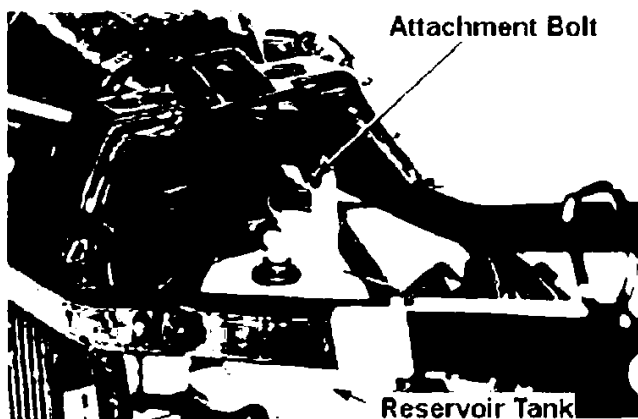

Disconnect the drain tube and overflow tube  
from the reservoir tank.  
Slide the projection on the bottom of the  
reservoir tank backwards and detach from  
the subframe.

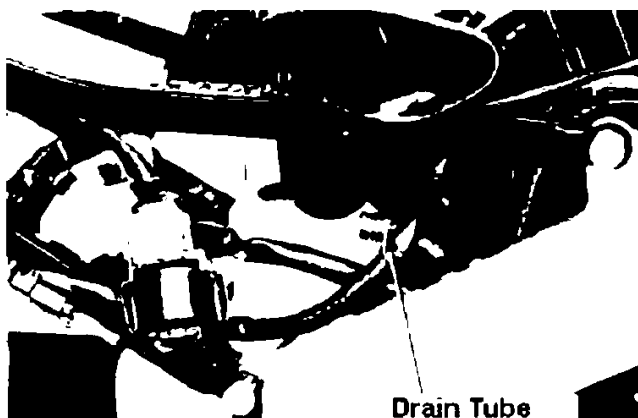

#### Attachment

Reverse the detachment procedure.

Put the tubes through designated parts.  
(1-22)

• Assembly

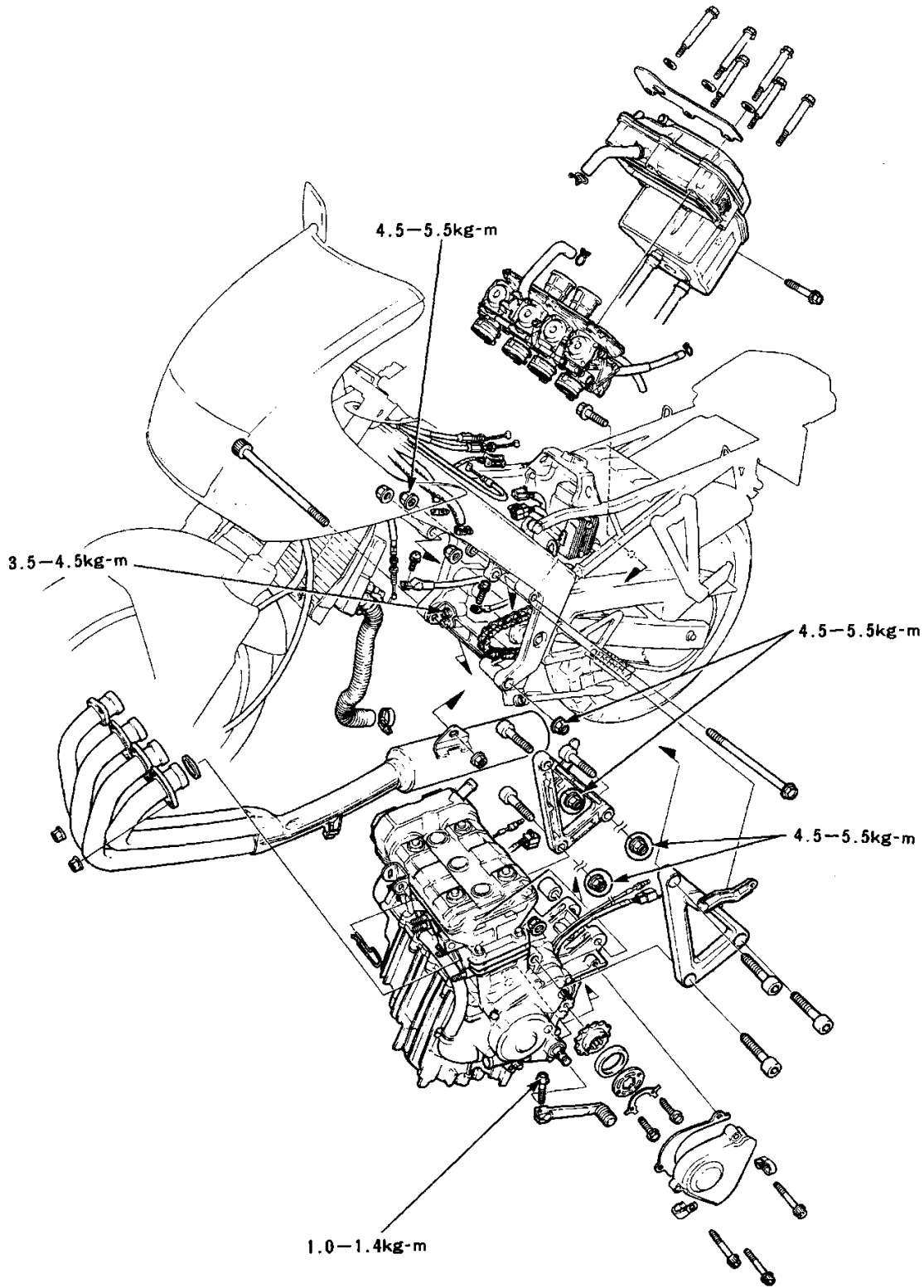



Assembly	6 – 0	Removal	6 – 2
Maintenance Information	6 – 1	Refit	6 - 5

### General Caution

The following items are to be serviced with the engine removed from frame.

- crank shaft, conrod, cylinder, piston
- transmission
- shift drum, shift fork (except for the shift linkage)

Support the bottom part of the engine with a garage jack for remove/refit.

### Maintenance Standard

Weight		49kg
Recommended Oil		Genuine Honda Ultra GP (4 cycle motorbike) SAE low 40 or SAE 20w-50 API – SE or – SF class oil (refer to 3-2 for viscosity)
Oil Capacity	Total	2.7 <sub>l</sub>
	Oil change	2.2 <sub>l</sub>
	Oil and filter change	2.4 <sub>l</sub>

### Torque:

Top engine mount bolt (10mm bolt, nut)	4.5 ~ 5.5kg m
Rear upper engine mount bolt (10mm bolt, nut)	4.5 ~ 5.5kg m
Rear lower engine mount bolt (10mm bolt, nut)	4.5 ~ 5.5kg m
Engine hanger bracket (8mm bolt)	3.5 ~ 4.5kg m
Change pedal	1.0 ~ 1.4kg m
Starter motor terminal cable	0.8 ~ 1.2kg m

Drain engine oil (2-16)  
Drain radiator fluid (5-3)  
Remove the seat and side covers.  
Remove the fuel tank (4-3)  
Disconnect the leads from the battery.  
Disconnect the two connectors and detach, the wire harness from an air cleaner case.  
Detach the air cleaner case by removing 7 bolts.

Remove the carburettor (4-8)

After detaching the carburettor, seal the intake manifold with adhesive tape.

Disconnect the two water hoses and four plug caps.

Disconnect the earth cable and the terminal cable.

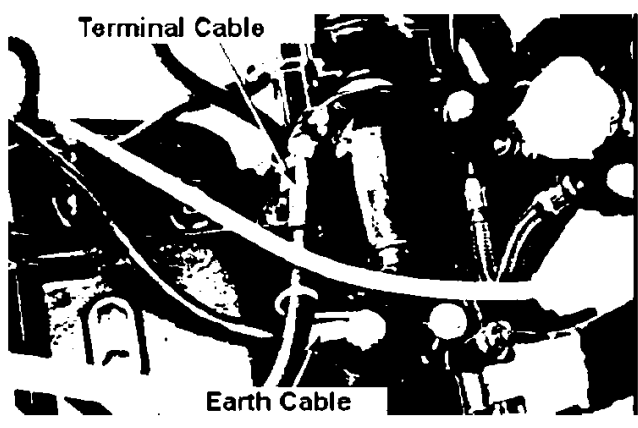
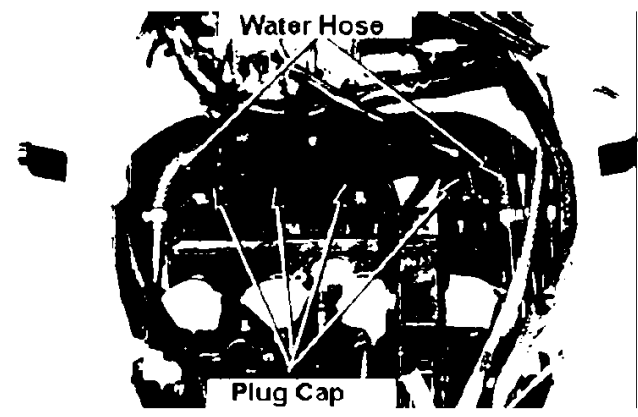
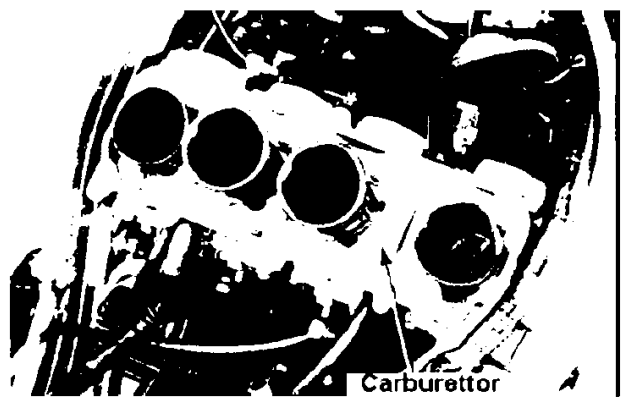
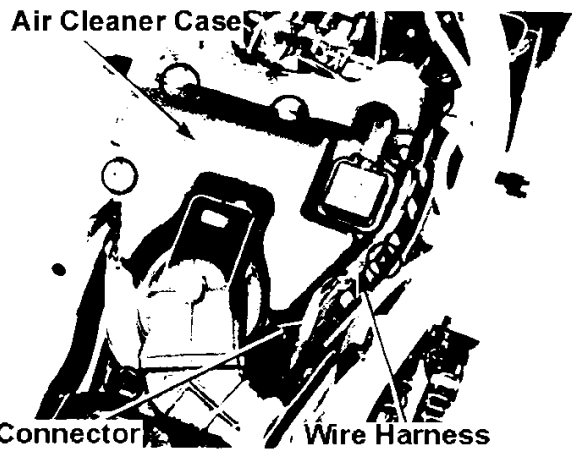

Disconnect the pulse generator coupler and the AC generator coupler.

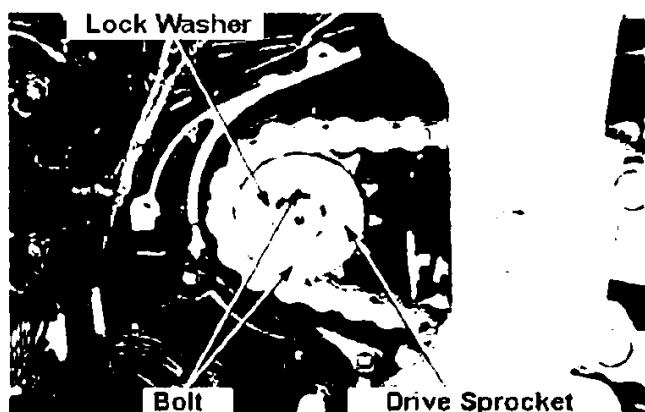

Disconnect the clutch cable.  
Disconnect the exhaust pipe.

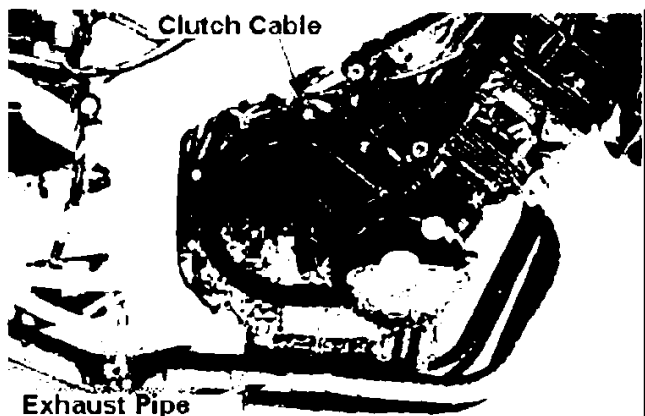

Disconnect the radiator hose and bypass tube.  
Remove the drive sprocket cover and remove the pulse generator wire and oil pressure switch wire from the clamp.

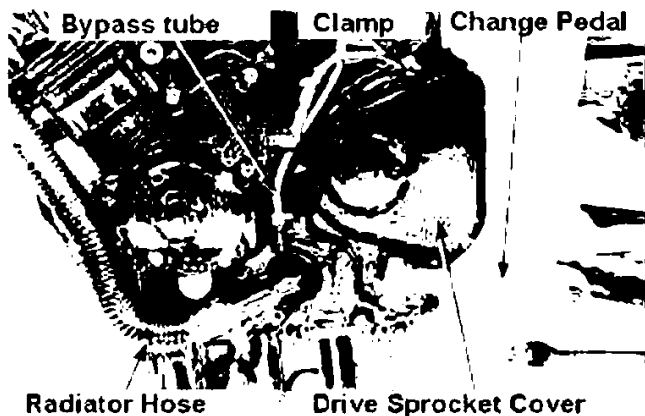

Loosen the rear axle nut and loosen the tension of the drive chain.  
Stretch the catch of the lock washer and remove the two bolts. Remove the lock washer and the drive sprocket.

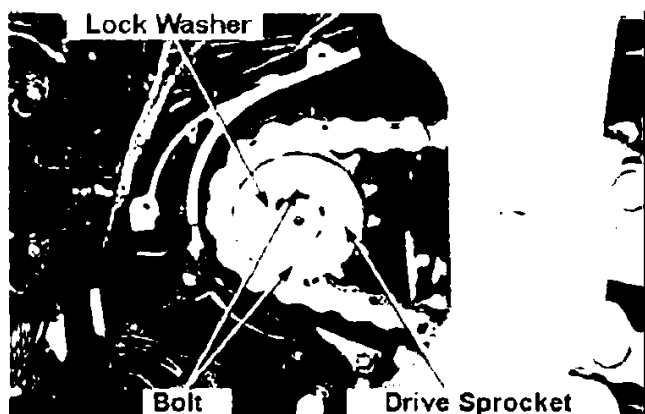

Remove the radiator set pin.  
Swing the radiator forward and fix to the frame.

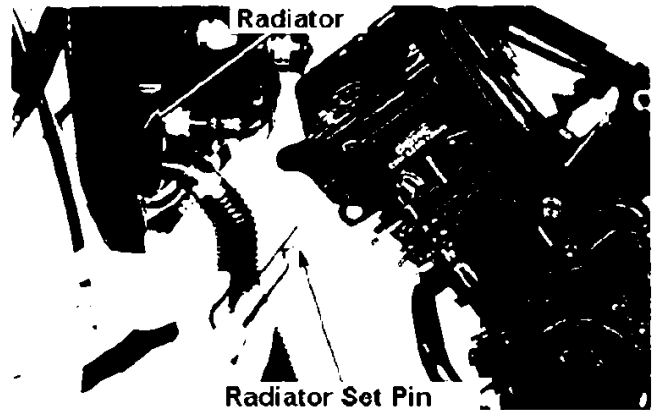

Remove three bolts and detach the engine hanger bracket.

Support the engine with a jack.

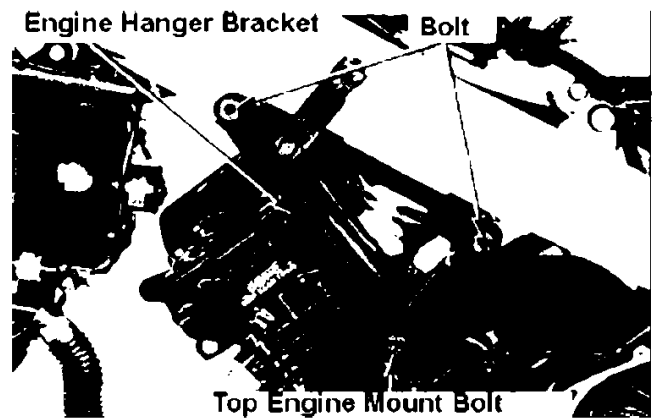

Remove the rear upper engine mount bolt and rear lower engine mount bolt.  
Remove the engine from the frame.

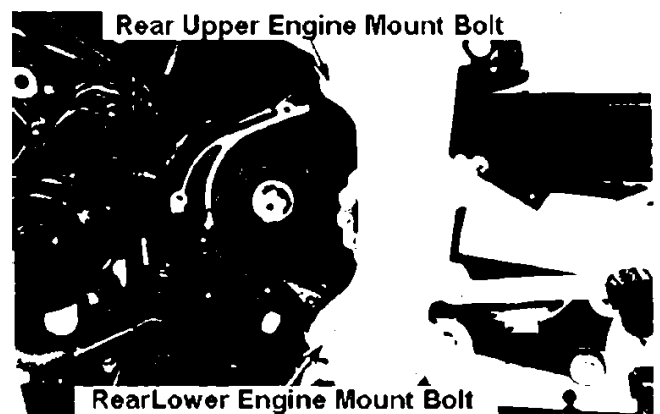

**Engine Refit**

Reverse the removal procedure for the refit.



- Do not damage the harness and cables.
- Do not damage the frame, bolts and screws.
- Firmly lock the drive sprocket bolt with a catch or a lock washer.
- Apply leads, tubes and hoses through the proper places (1-22)

**Torque:**

Top engine mount bolt	4.5 ~ 5.5kg m
Rear upper engine mount bolt	4.5 ~ 5.5kg m
Rear lower engine mount bolt	4.5 ~ 5.5kg m
Engine hanger bracket	3.5 ~ 4.5kg m
Change pedal	1.0 ~ 1.4kg m

After the refit, conduct the following inspections / adjustments.

- Free movement of the clutch lever (2-8)
- Free movement of the throttle grip (2-17)
- Drive chain (2-9)
- Brake pedal (2-5)
- Engine Oil (2-15)
- Choke lever (2-17)
- Radiator (2-18)

• Assembly

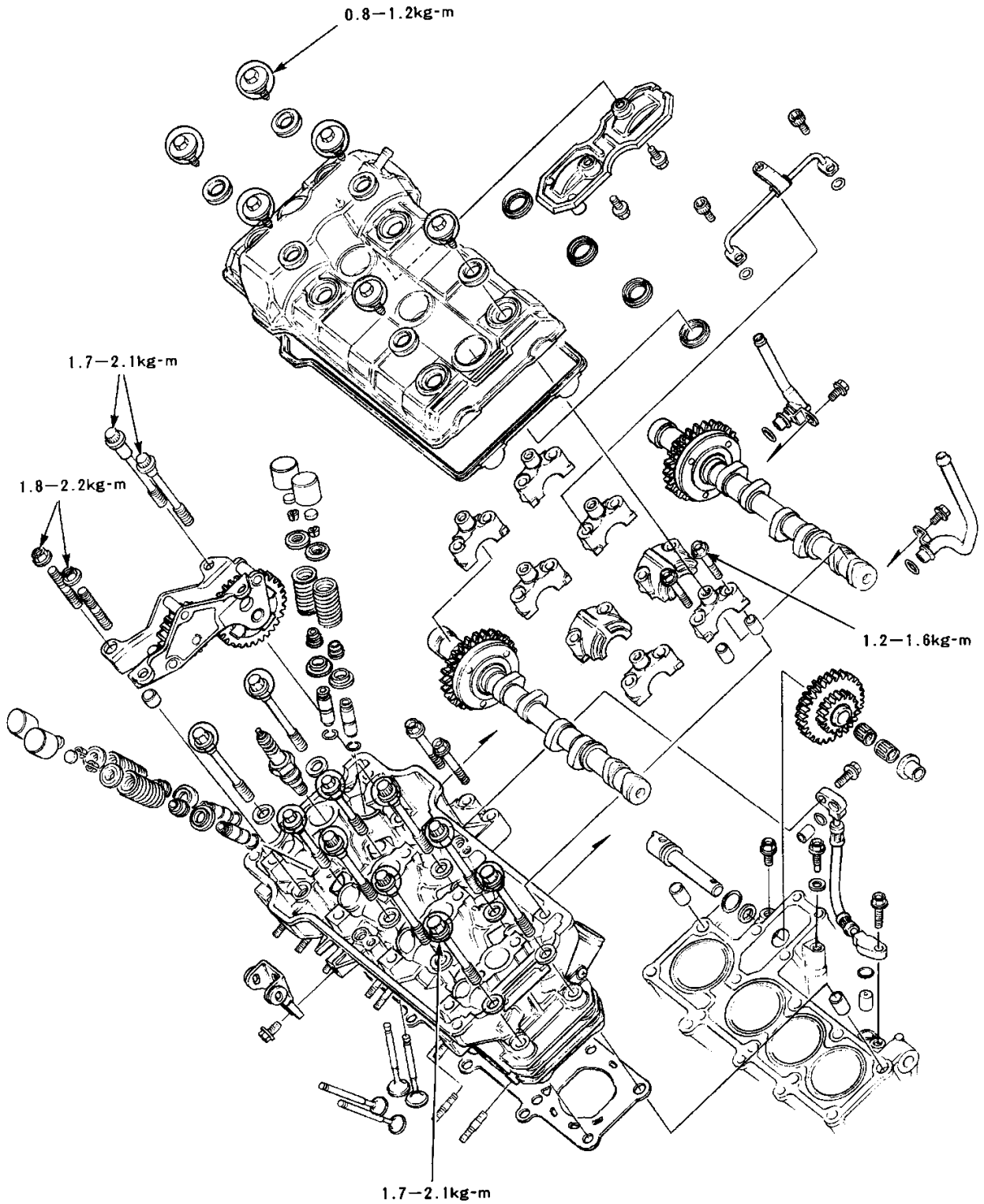

Assembly	7-0	Valve Seat Inspection/Adjustment	7-10
Maintenance Information	7-1	1 <sup>st</sup> Cam gear detachment	7-12
Troubleshooting	7-2	1 <sup>st</sup> Cam gear attachment	7-14
Cylinder head cover detachment	7-3	Cylinder head assembly	7-15
Cam shaft detachment	7-3	Cylinder head attachment	7-17
Cam gear train detachment	7-5	Cam gear train attachment	7-18
Cylinder head detachment	7-5	Cam shaft attachment	7-19
Cylinder head disassembly	7-6	Cylinder head cover attachment	7-21
Valve guide replacement	7-9		

## Maintenance Information

### General Caution

- Service related to the cylinder head and valves should be conducted on the vehicle.
- Oil is supplied to the camshafts through the oil pipe. Inspect the pipes for clogging.
- On assembly, apply MoS<sup>2</sup> grease on the cam shaft journals, cam surface and a valve lifter.
- Fill the oil pit on the cylinder head with clean oil.

### Maintenance Standard

			Standard	Limitation
Compression			13.0kg/cm <sup>2</sup> -400rpm	-
Cam shaft	Cam Lift	I N	29.3	29.15
		E X	29.0	28.85
	Oil Clearance	1	0.015-0.057	0.06
		2	0.015-0.057	0.06
		3	0.025-0.067	0.07
		4	0.015-0.057	0.06
Displacement		-	0.05	
Valve Spring	Relaxed Length		37.3	36.3
Valve,	Valve Stem Outer Dia.	I N	3.970-3.995	3.965
		E X	3.950-3.975	3.935
Valve guide	Valve Stem Inner Dia.	I N	4.000-4.012	4.065
		E X	4.000-4.012	4.065
	Stem guide clearance	I N	0.005-0.042	0.10
		E X	0.005-0.050	0.13
Valve lifter	Valve seat contact width	I N	0.8	1.3
		E X	1.0	1.5
Outer diameter			19.978-19.993	19.970
Cylinder head	Strain/Distortion		-	0.05
	Valve lifter contact surface dia.		20.010-20.026	20.035

## Torque

Cylinder head cover	0.8~1.2kg m	Cylinder head (7mm bolt, apply oil)	1.7~2.1kg m
Cam shaft holder	1.2~1.6kg m	Gear train holder (7mm bolt, apply oil)	1.7~2.1kg m
Engine mount bolt	4.5~5.5kg m	(8mm nut)	1.8~2,2kg m

## Tools

### Exclusive Tools

Valve guide reamer	07984-8840000
Valve guide remover	07GMD-KT70100
Valve Spring Compressor Attachment	07GME-KT70200
Tappet hole protector	07GME-KT70100
Socket wrench	07GMA-KT70100

### Common Tools

Valve Spring Compressor	07757-0010000
-------------------------	---------------

### Valve seat cutter

Seat surface cutter (20.5mm, 45° IN)	07780-0011000
Seat surface cutter (17mm, 45° EX)	07GMH-KT70500
Flat surface cutter (20mm, 32° IN)	07GMH-KT70100
Flat surface cutter (17mm, 32° EX)	07GMH-KT70200
Inner surface cutter (20.5mm, 60° IN)	07780-0014300
Inner surface cutter (17mm, 60° EX)	07GMH-KT70400
Cutter holder (4mm)	07GMH-KT70300

## Troubleshooting

Cylinder head related troubles are detected by compression measurement or a noise from the top part of the engine.

### Too low or unstable compression

- Valve
    - Inadequate valve clearance
    - Valve bent/heat deformation
    - valve spring failure
  - Cylinder Head
    - Head gasket leak
  - Cylinder / Piston failure (→ Sec. 9)
- valve timing failure
  - insufficient valve seat contact
  - Head distortion / crack

### Too high compression

- Carbon on pistons, combustion chambers.

## Noise

- Inadequate valve clearance
- Valve heat deformed or valve spring damaged / worn out
- Cam shaft damaged / worn out
- Cam gear train damaged / worn out
- Cam sprocket worn out



### Cylinder head cover detachment

Detach the side cowl (13-4)  
Remove the radiator set pin. Swing the radiator forward and fix it to the frame.

It can be easily removed by pushing the head of the radiator set pin down and pulling out.

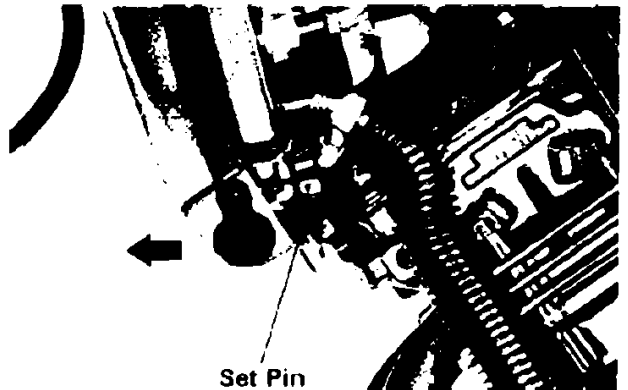

Disconnect the radiator holder from the cylinder head.  
Disconnect the breather tube from the cylinder head cover.  
Remove spark plug caps.

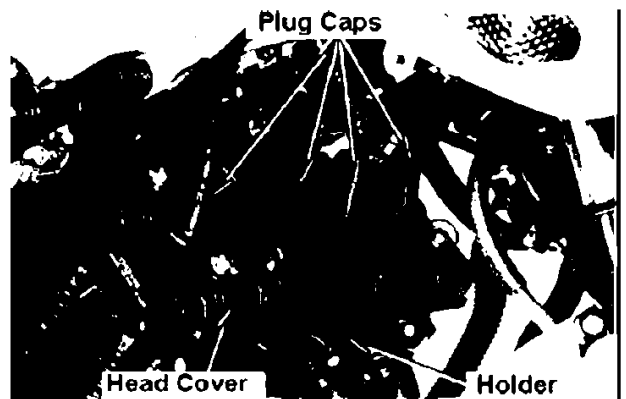

Inspect the cylinder head cover gaskets.

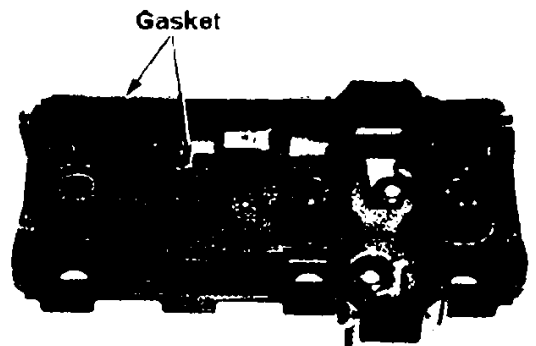

### Cam shaft detachment

Remove the cylinder head cover.  
Remove oil pipe attachment bolt.  
Remove the cam shaft holder attachment bolt and detach the oil pipe, O-Ring, and the cam shaft holder.

No need to remove the knock pin on the camshaft holder if it is difficult.

Detach the camshaft.  
Inspect the oil pipe for clogging, deformation and damage.

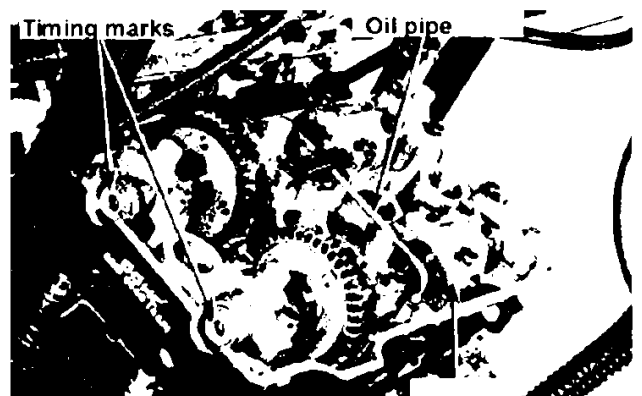

### Cam shaft inspection

Inspect the cam gear for damage.  
Inspect the journal surface for wear/damage.  
Support the both ends of the shaft and measure its bend with a dial gauge.  
Take half of the indicated valve.

More than 0.05mm → Replace

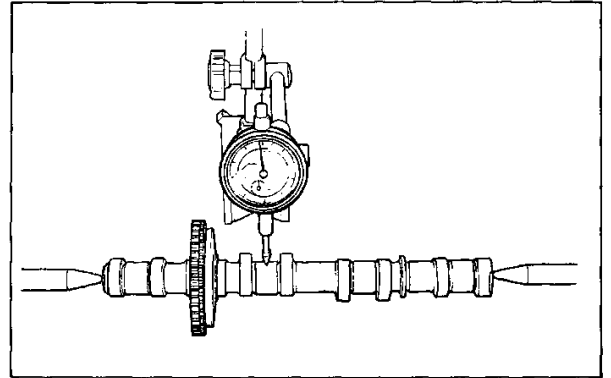

Inspect the cam surface for irregular wear/damage.  
Measure each cam lobe height.

IN: Less than 29.15mm → Replace

EX: Less than 28.85mm → Replace

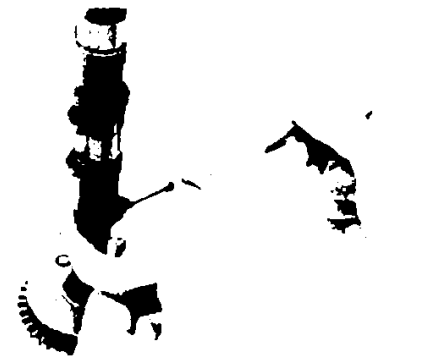

### Camshaft oil clearance inspection

Wipe off the oil from camshaft journal, camshaft holder and cylinder head journals.

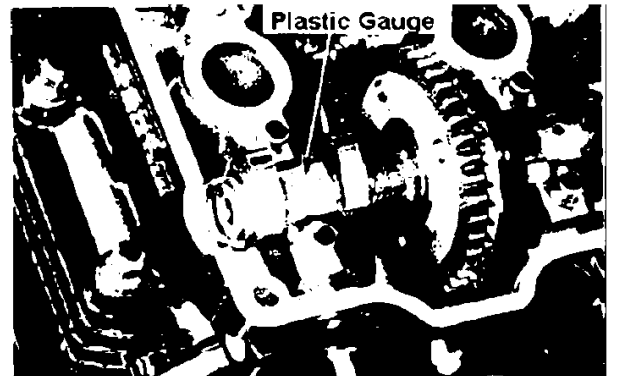

Attach the camshaft.  
Apply plastic gauges on each journal surface.

Attach the cam shaft holder and tighten the bolts.  
Torque: 1.2~1.6kg m

- Take caution with the cam gear contact.
- Ensure the camshaft will not spin.
- Tighten the bolts equally.



Remove the cam shaft holder and detach the camshaft.

Measure the widest plastic gauge on each journal surface.

Limitation: No. 1,2,4 equal to or more than 0.06→replace.  
No. 3 equal to or more than 0.07→replace.

If the figure is above the limit, replace the camshaft and re-measure the oil clearance.  
If the figure is still beyond the limit, replace the cylinder head and the holder.

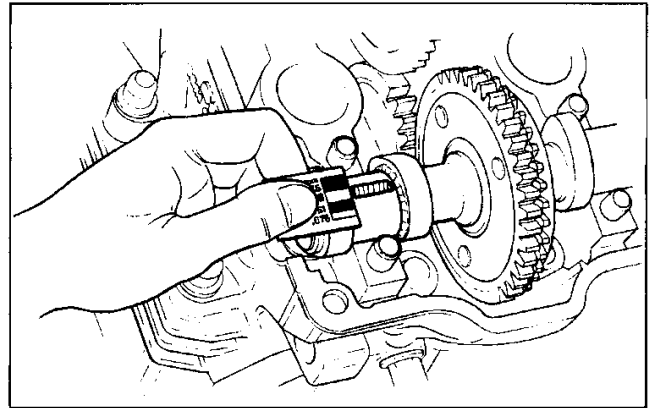

### Cam gear train detachment

Remove the two cam gear train attachment bolts, two nuts and detach the cam gear train.  
Remove the knock pin.

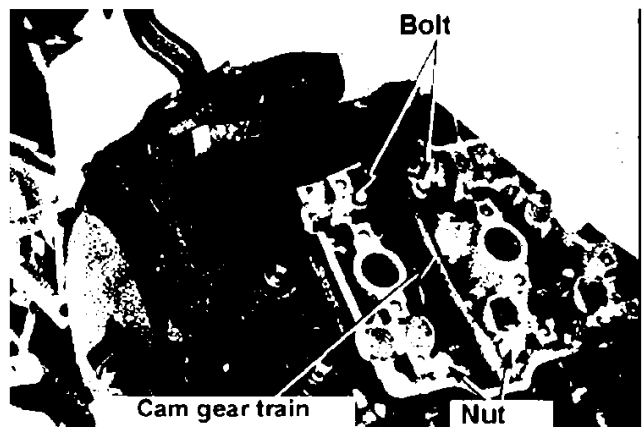

Inspect the gear on the gear train for smooth rotation and damage.



### Detachment of the cylinder head

Detach the cam shaft (7-3)

Detach the following parts:

- Fuel tank (4-3)
- Air cleaner case (4-6)
- Carburetor (4-8)
- Exhaust pipe (16-2)

Remove the oil pipe and the O-Ring, knock pin and oil orphis.

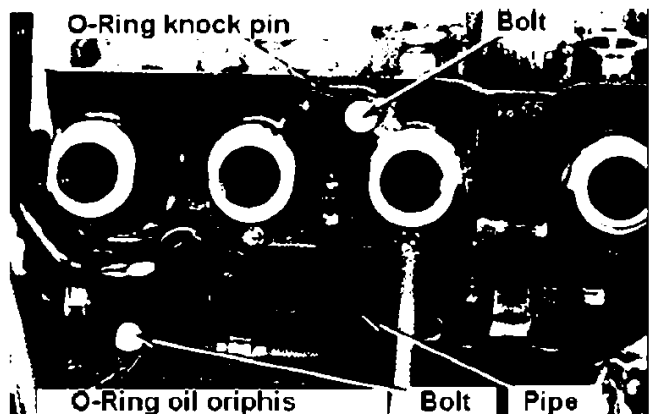

Disconnect the hoses from the water pipe on the cylinder head.

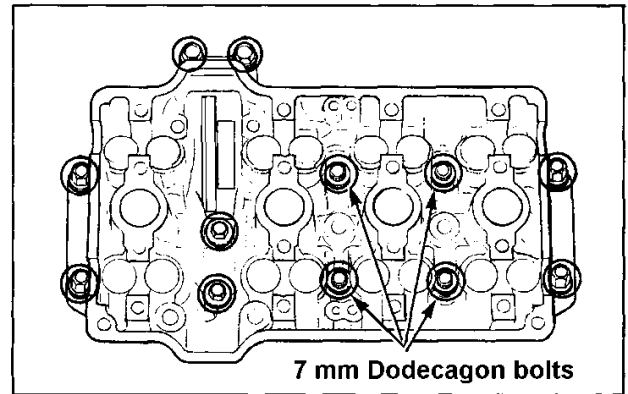

Remove the cylinder attachment bolts and detach the cylinder head.

- Loosen the bolts in two or three steps by opposite corners.
- Use of the exclusive tool is recommended to remove the bolts.
- Exclusive tool: Socket wrench 07GMAKT70100

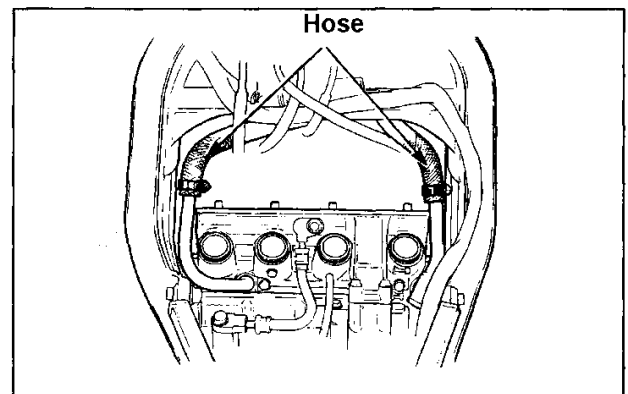

Remove gasket and knock pin.

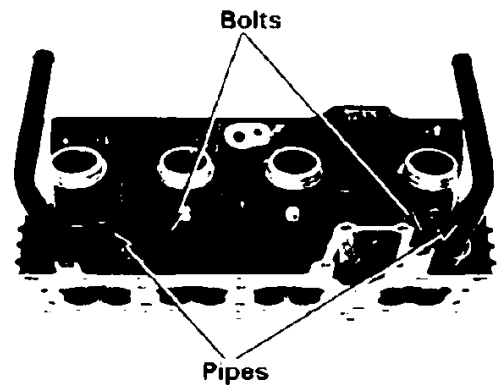

### Cylinder head disassemble

Remove O-Ring and water pipe from the cylinder head.

Remove valve lifters and shims.

Mark the attachment position on the lifters and shims.

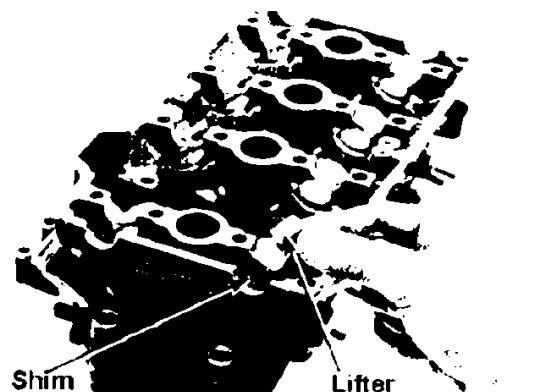

Attach the tappet hole protectors to the cylinder heads.

**Exclusive tool:** Tappet hole protector  
07GME-KT70100

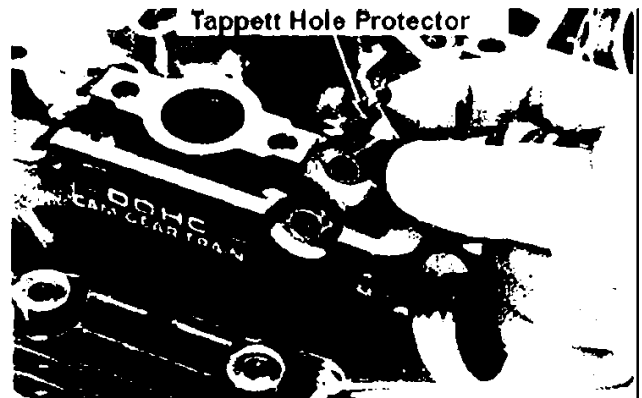

Remove the following items by using a valve spring compressor and the attachment.

⇒ cotter ⇒ valve  
⇒ retainer ⇒ valve stem seal  
⇒ spring ⇒ spring seat

**Common tool:** Valve spring compressor  
07757-0010000

**Exclusive tool:** Valve spring compressor attachment  
07GME-KT70200

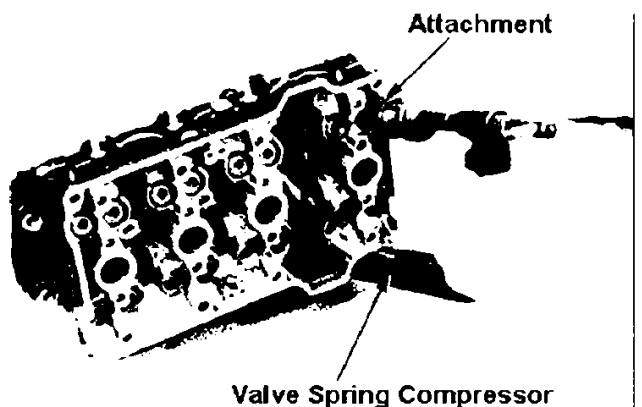

- Do not apply excess load on the valve springs.
- Mark the attachment position on each part.

### Cylinder head inspection

Remove carbon in combustion chambers.  
Remove the gasket pieces from the head gasket surface.

Do not damage the gasket surface

Inspect the spark plug hole and valve hole for cracks.

Measure the distortion of the cylinder head by using a straight edge and a thickness gauge.  
Equal to or more than 0.05mm→replace.

Inspect the oil path on the cylinder head for clogging.

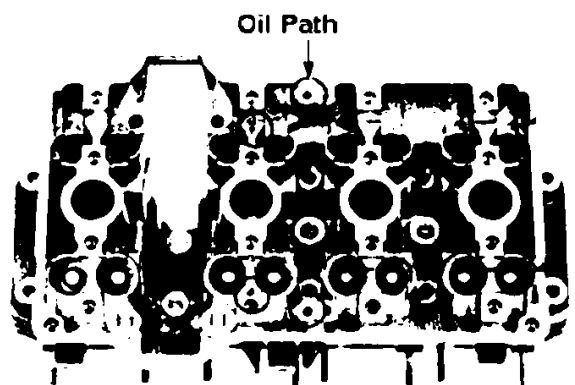
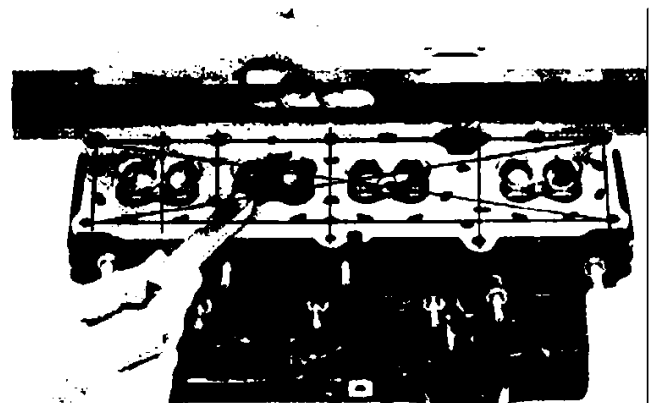

Inspect the valve lifter bore for damage and irregular wear.

Measure the inner diameter.

Equal to or less than 20.035mm → replace.

### Inspection of the valve lifter.

Inspect the lifter for damage/irregular wear.

Measure the out diameter

Equal to or less than 19.970mm → replace.

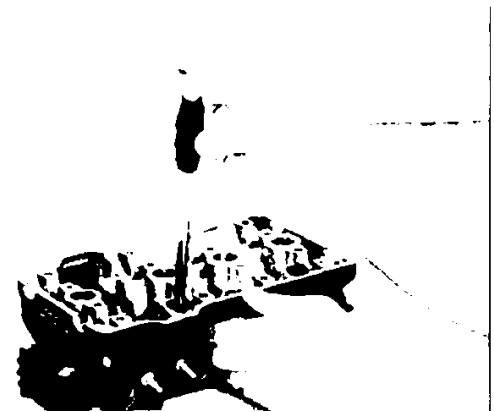

Valve Lifter

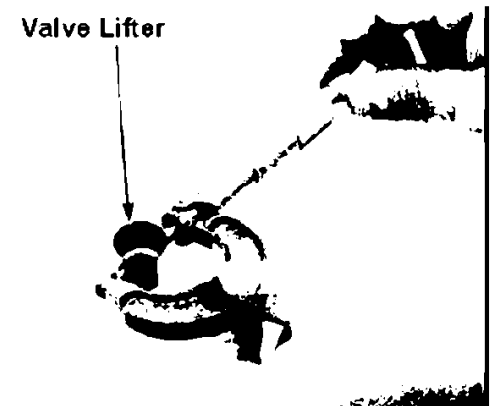

### Valve spring relaxed length

Equal to or less than 36.3mm → replace.



### Valve stem / valve guide inspection

Inspect each valve for bend, heat damage, damage, irregular wear at the stem edge.

Place the valve to a guide and check for smooth operation.

Measure the outer diameter of each valves stems.

IN:

Equal to or less than 3.965mm → replace.

EX:

Equal to or less than 3.9350mm → replace.



- Before measuring the valve guide, apply a reamer through a guide and remove carbon.

### Exc. Tool

Valve guide reamer - 07984 – 884000

Measure inner diameter of each guides.  
Equal to or greater than 4.065mm → replace.

(Stem-guide clearance)  
= (valve guide inner diameter) –  
(corresponding valve stem outer diameter).

### Stem to guide clearance

IN:

Equal to or greater than 0.10mm → replace.

EX:

Equal to or greater than 0.13mm → replace.

If the figure is beyond the limit, calculate the clearance assuming the guide is the new one. If the assumption falls into the acceptable range, replace the guides only.

If the assumption still exceeds the limit, replace both the guide and the valve.

Cut the valve seat when the guide is replaced.

### Valve guide replacement

Hit the valve guide through the cylinder head.

Do not damage the cylinder head.

### Exc, Tool

Valve guide remover  
07GMD – KT70100

Hit the oversized valve guide in.

### Exc. Tool

Valve guide remover  
07GMD – KT70100

Valve Guide Remover

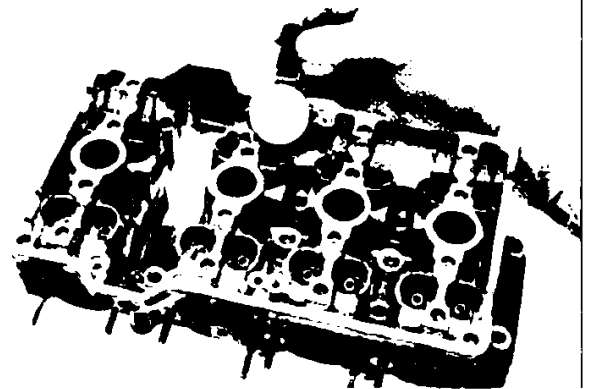

Valve Guide Remover

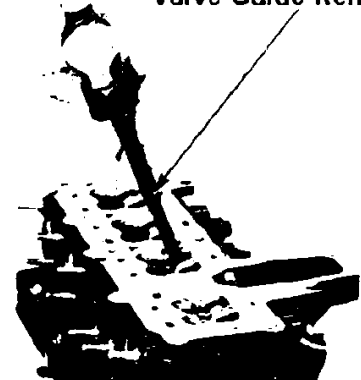

Valve Guide Remover



Finish the valve guide with a reamer.

Use lubrication when reaming.

**Exc. Tools**

Valve guide reamer  
07984 – 8840000

Clean the cylinder head and remove all debris.  
Adjust the contact of the valve seat.

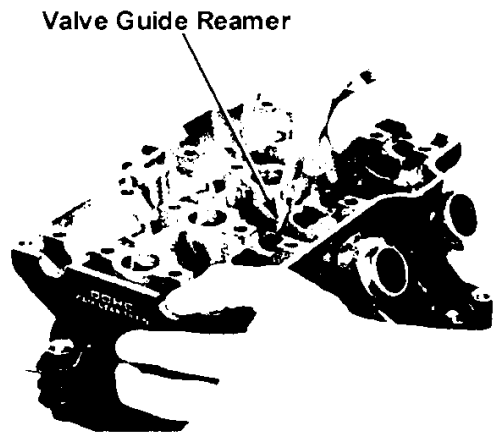

Valve seat inspection / adjustment

Valve seat inspection

Remove carbon from valves.  
Apply lead (red dye) powder over the contact surface. Contact the valve by using a valve lapping stick.

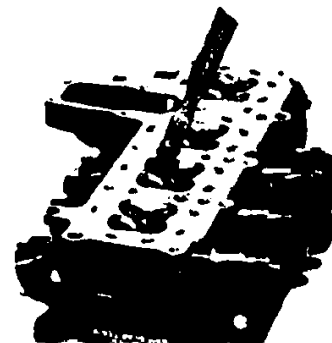

Detach valves and inspect the valve faces.

Replace if you discover irregular wear or roughness on the surface.

**Standard:** IN: 0.8mm  
EX: 1.0mm

**Circuit:** IN: Equal to or above 1.3mm  
→ adjust

EX: Equal to or above 1.5mm → adjust

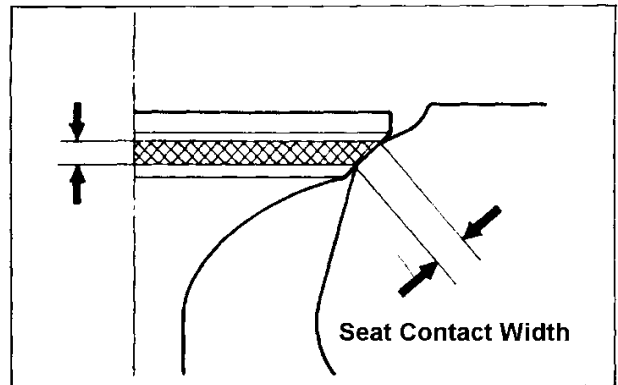

If the contact span is unequal, too wide, too narrow, contacting only at the top or bottom, adjust the valve seat with a valve seat cutter.

Valve seat adjustment

See the valve seat cutter manual.

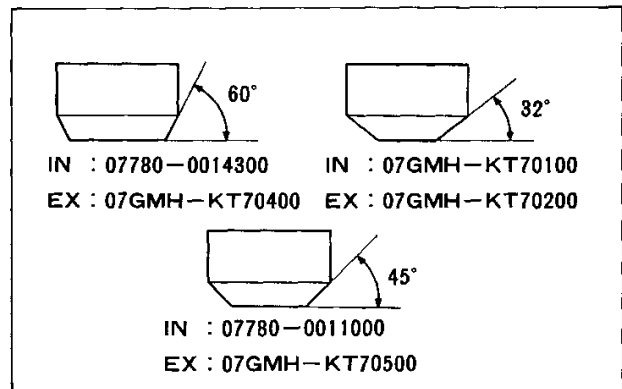



Apply 4 ~ 5kg pressure by hand and rotate the cutter for the adjustment.

Apply engine oil to the cutter to remove the debris

Use 45° cutter to grind the surface until the roughness or pin holes disappear from the seat surface.

Do not grind too much.

Use 32° cutter for flat surface adjustment.

Use 60° cutter for inner surface adjustment.

Use 45° cutter to adjust the seat surface until it reaches to the specific width.

Standard valve seat width

IN: 0.8mm  
EX: 1.0mm

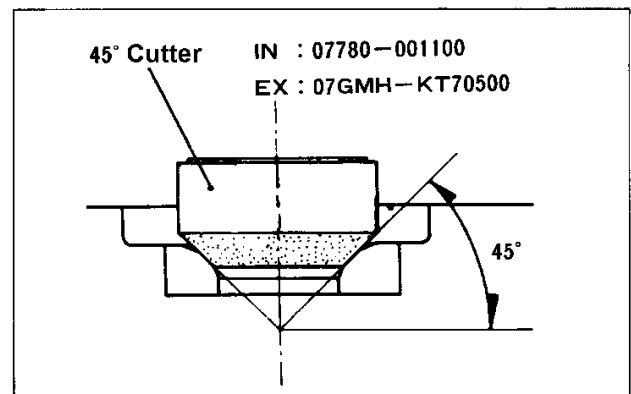
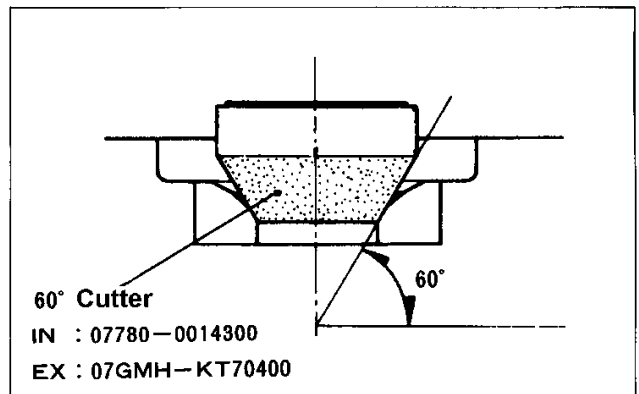
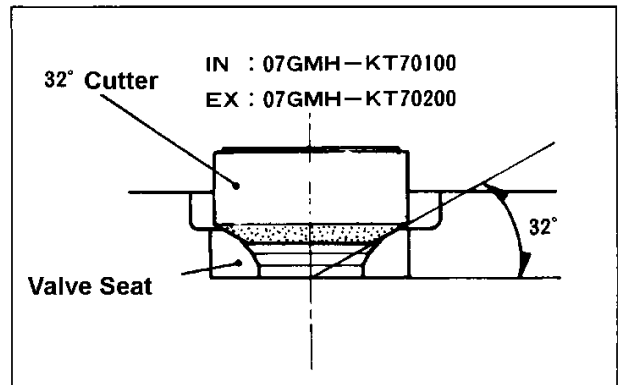
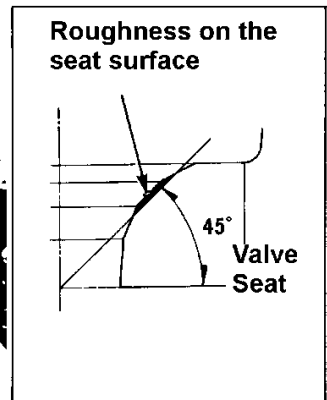

Apply the red dye on the valve seat.  
Attach the valve. Confirm the contact position by gently pushing and rotating the valve.

If the contact position is too high, grind with a 32° cutter and adjust to the standard width with a 45° cutter.

If the position is too low, use 60° cutter and adjust to standard with a 45° cutter.

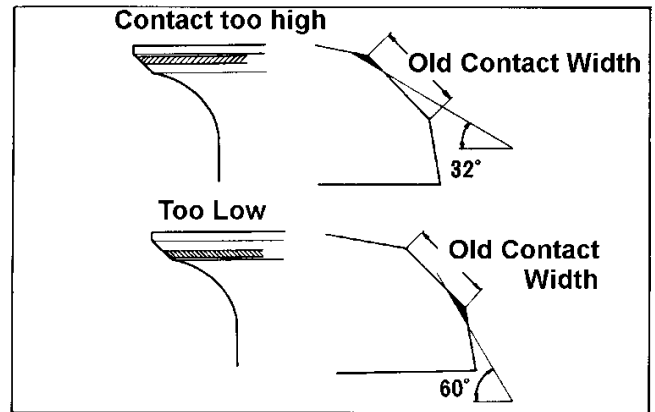

After the adjustment, apply compound over the valve face and chafe with a valve lapping stick. Clean and wash the cylinder head and valve.

- Do not press the valve hard as it scratches the surface.
- The compound should not go into the stem or the guide.

After the adjustment, use the red dye to check the 45° seat surface contacts with the valve equally on it's centre.

### First Cam gear detachment

Remove the right engine hanger bracket.

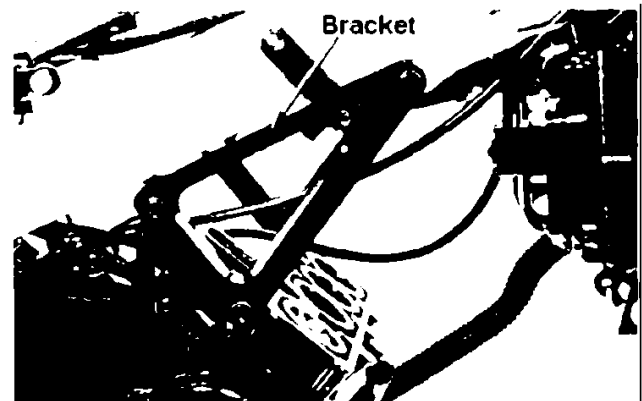
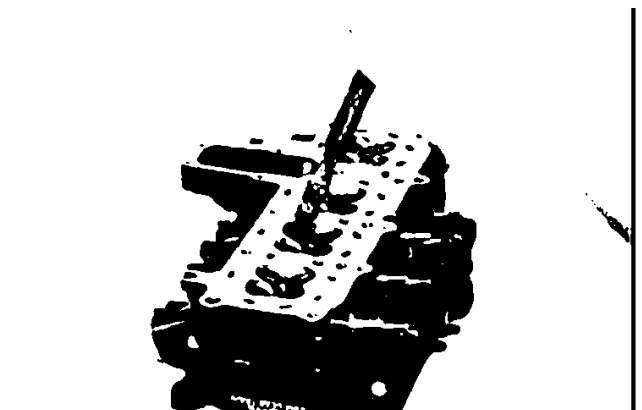

Remove two bolts.  
Pull out the shaft.  
Detach the 1<sup>st</sup> cam gear and the collar.

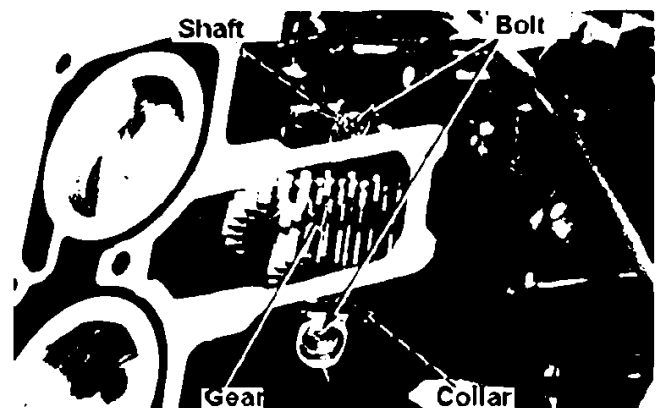

Inspect each part for damage or wear.

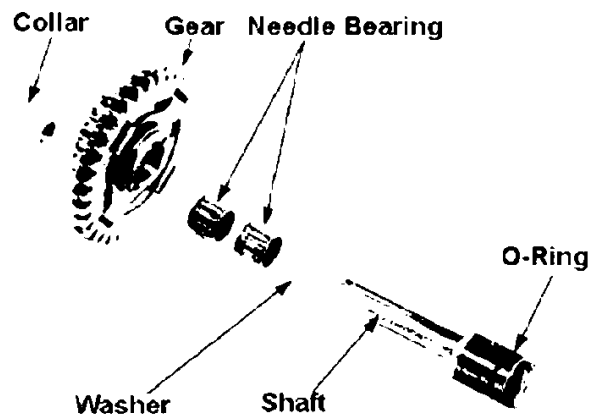

### First cam gear disassembly

Remove the snap ring.  
Detach the wave spring, first gear plate.

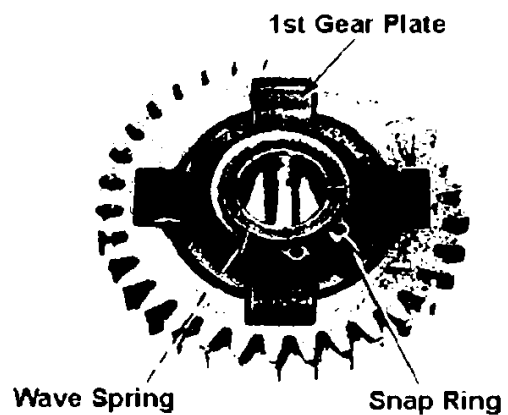

Remove the sub gear and springs.

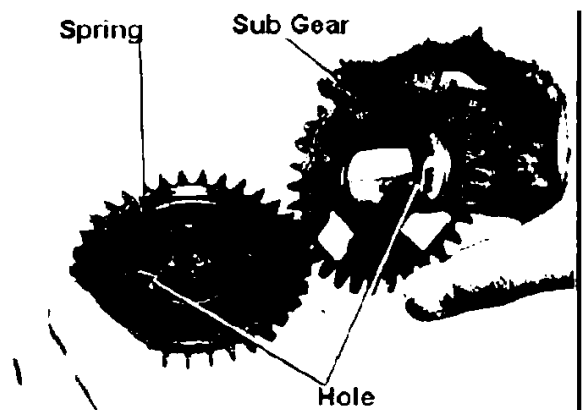

### First cam gear assembly

Attach the four springs to the first cam gear.  
Align the holes on the sub gear and the first gear and attach.

Install the wave spring.

Face the concave side of the wave spring to the gear side when installing.

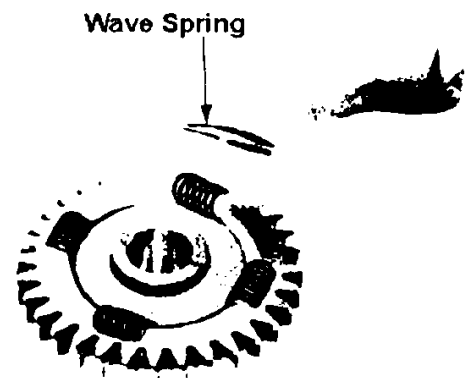

Attach the first gear plate.

Firmly attach the snap ring to the slit on the first cam gear.

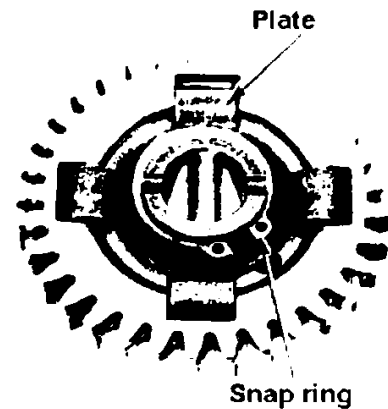

### First cam gear attachment

Attach the collar to the hole in the cylinder block. Attach two needle bearings to the first cam gear and attach it to the cylinder block.

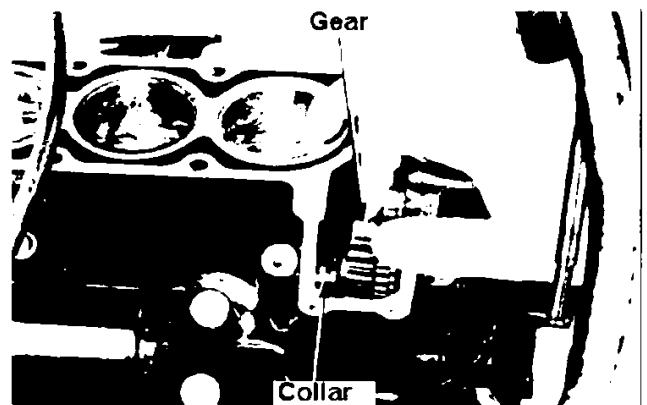

Attach the washer to the shaft and apply engine oil to the O-Ring. Match the first cam gear and sub gear and insert the shaft.

- Do not damage the gear.
- Align the carved line parallel to the cylinder block top surface.

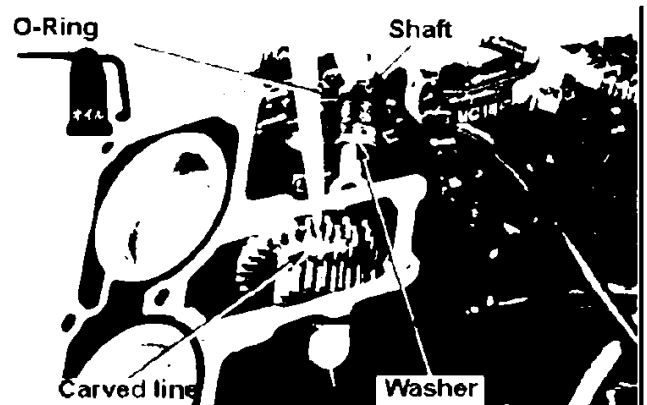

Fix the shaft with two bolts and sealing washers.

Tighten in accordance with the order shown in the figure.

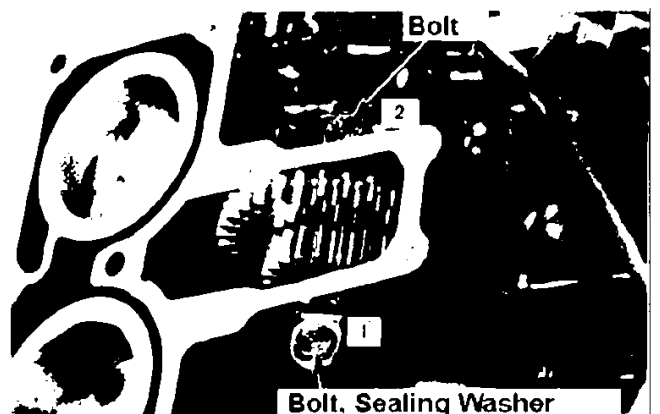

Attach the rear engine hanger bracket and tighten the bolts / nuts.

Torque: 4.5 ~ 5.5kg m

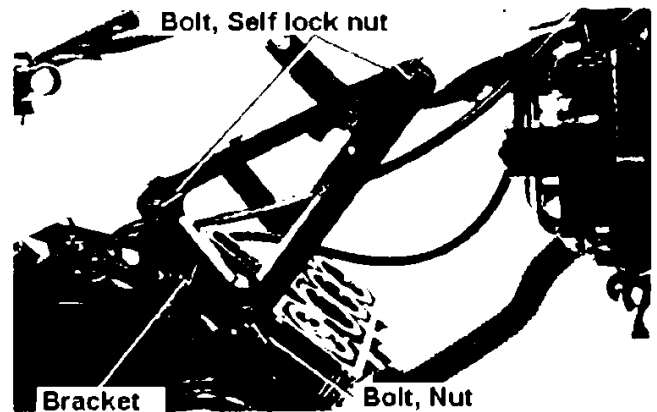

### Cylinder head assembly

Attach the spring seats, new stem seals.  
Apply small amounts of MoS<sup>2</sup> grease to the valve stems and insert to the guides.  
Attach the valve springs and retainers.

- The narrow pitch of the valve springs come to the head side.
- Replace with new valve stem seals if they were detached.
- Slowly turn the valve stem and insert to the guide.

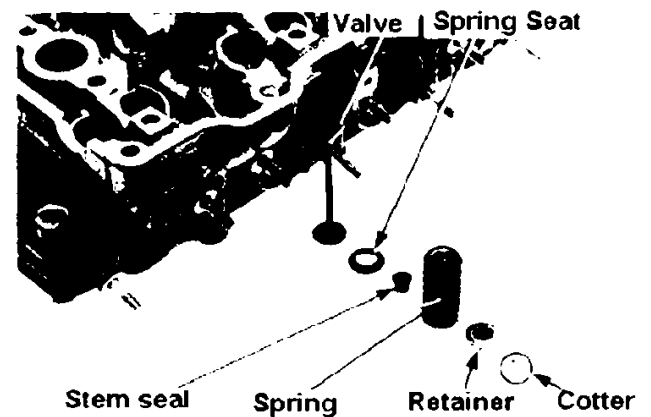

Attach tappet hole protectors.

#### Exc. tools

Tappet hole protectors  
07GME – KT70100

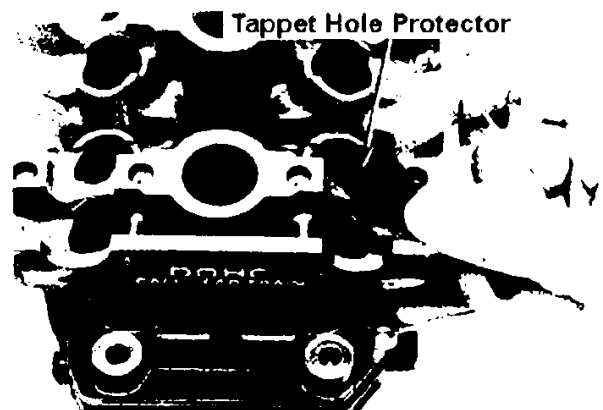

Attach the valve cotter by using a valve spring compressor and an attachment.

#### Common tools

Valve spring compressor  
07757 - 0010000

#### Exc. tools

Valve spring compressor attachment  
07GME – KT70200

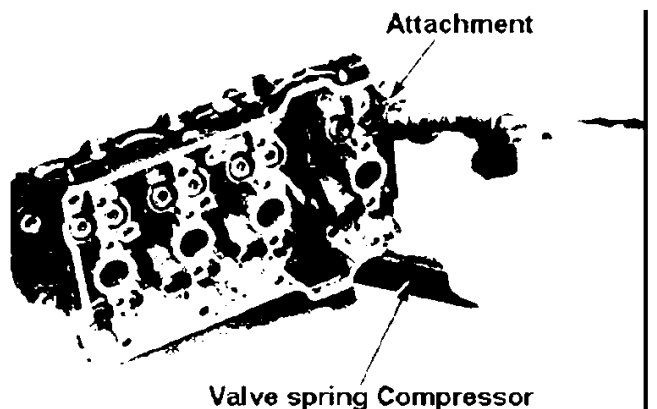

Do not over compress the valve spring

Gently hit the valve stem end a few times and let the valve and the cotter match.

Do not damage the valve

Attach new O-Rings to the water pipes.  
Attach the pipes to the cylinder head.  
Tighten the bolts.



Water pipe

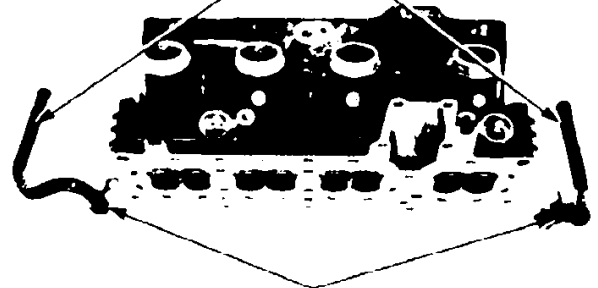

O-Ring

Attach the lifter shim in to it's original position.

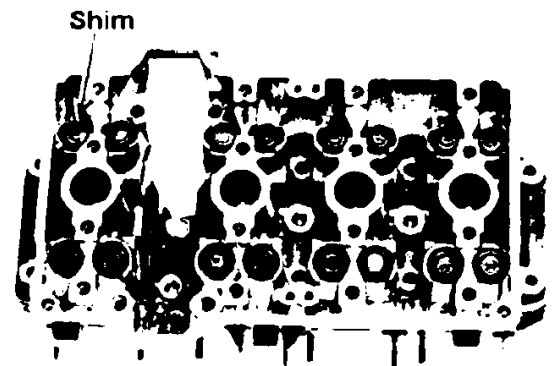

Shim

Apply grease on the contact surface over the outer surface of the lifter.  
Place the lifter in to it's original position.

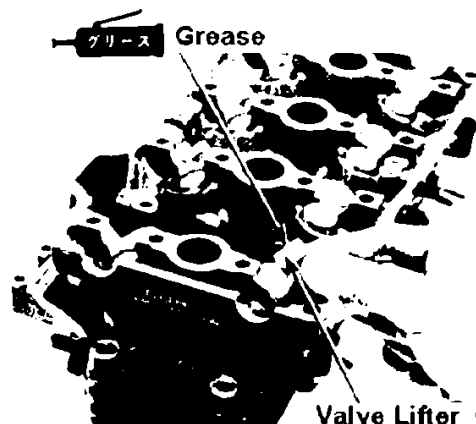

Grease

Valve Lifter

### Cylinder head attachment

Inspect the oil orphis on the cylinder block for clogging.

Apply engine oil to the O-Ring and attach it.

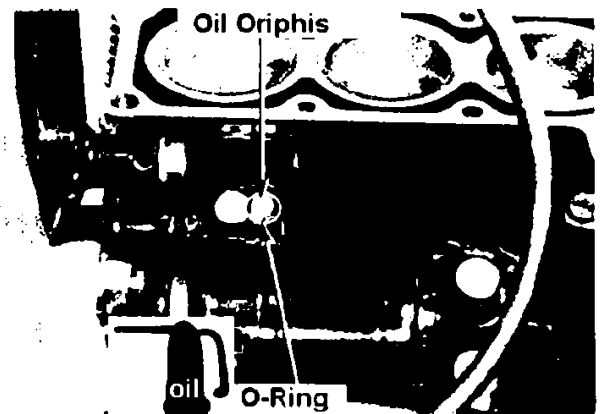

Connect the oil path pipe to the cylinder block.

Apply sealer to the thread of the attachment bolt and tighten.

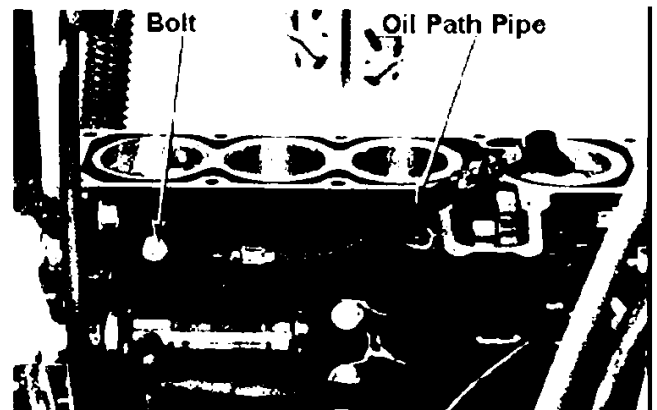

Attach knock pins and a new gasket.

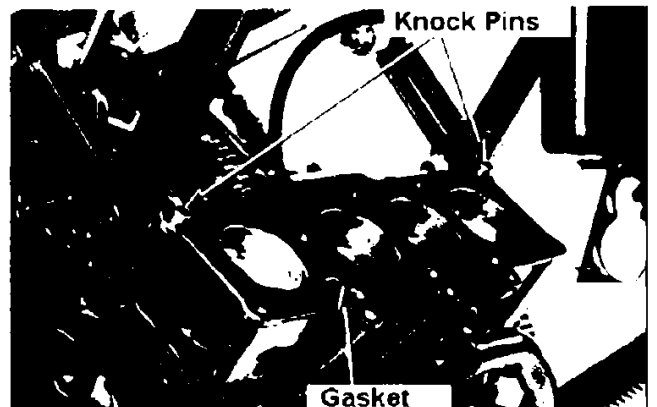

Attach cylinder head.

Apply engine oil to the cylinder head attachment bolts and washers.

Attach them to the cylinder heads and tighten.

Torque: 1.7 ~ 2.1kg m (7mm bolt)

- Tighten from inner corners to opposite outer corners. Do not tighten at once.
- Use of an exclusive tool is recommended.

Socket wrench - 07GMA – KT70100

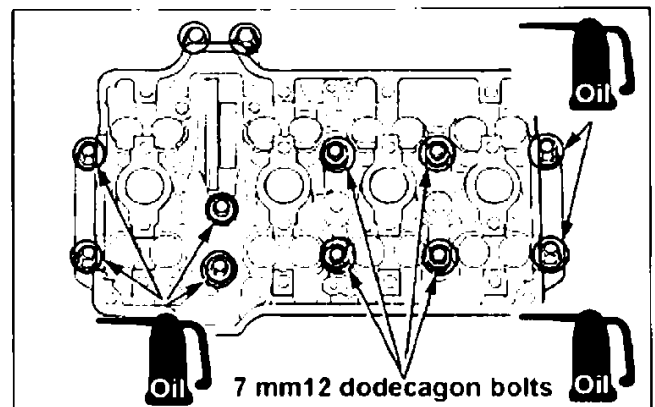

Apply engine oil to the new O-Ring and install it to the cylinder head.  
Attach the knock pin.  
Attach the oil path pipe to the cylinder head.

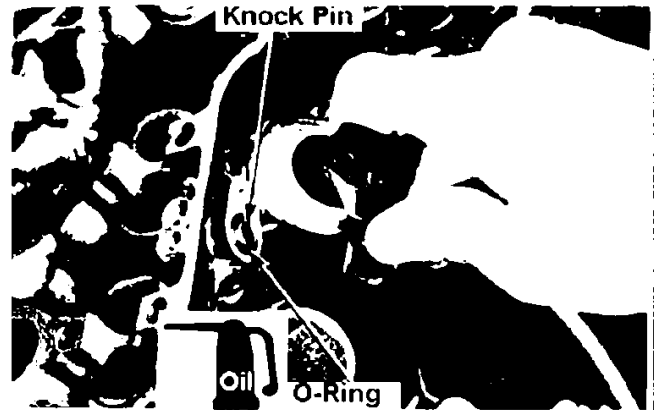

Connect water hoses to water pipes.

Tighten the hoses with clamps.

Attach the following parts:

- exhaust pipe (16-2)
- carburetor (4-18)
- air cleaner case (4-7)
- fuel tank (4-3)

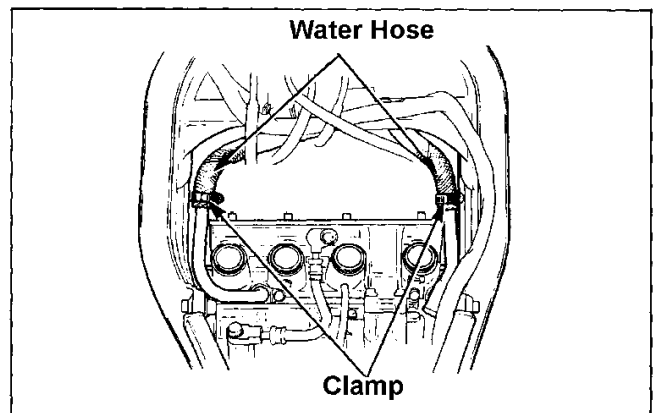

### Cam gear train attachment

Attach the knock pin to the cylinder head.

When replacing the stud bolt, apply screw locker (sealer) to the head attachment bolts before attachment.



Be aware that there are two different 7mm bolts.

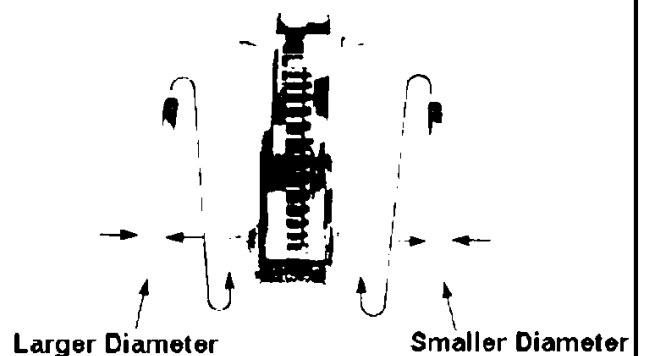



Attach the cam gear train. Tighten the bolts and nuts.

Torque:      7mm bolts:    1.7 ~ 2.1kg m  
                  8mm nuts:    1.8 ~ 2.2kg m

Ensure the proper gear match.

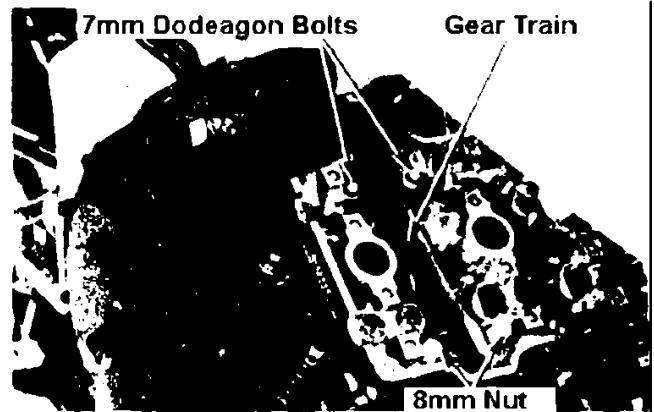

### Cam shaft attachment

Remove the crankshaft hole cap and the timing hole cap. Rotate the crankshaft clockwise and align the "T" mark on the fly wheel with the alignment mark.

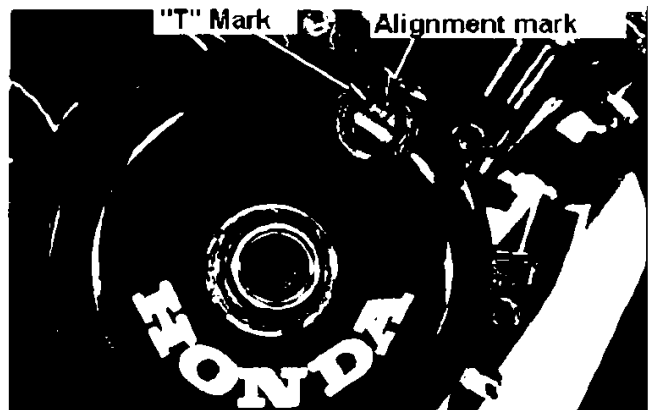

There are "IN" "EX" identification marks on the camshafts.

Apply grease on the journal and the cam surface of the camshaft.

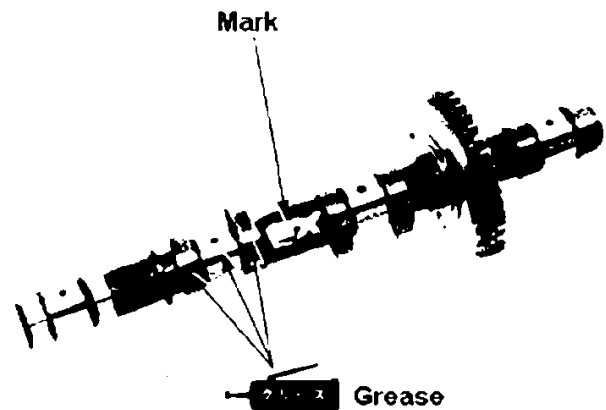

Apply grease on the journal or the cylinder head.

Attach the camshaft to the cylinder head.

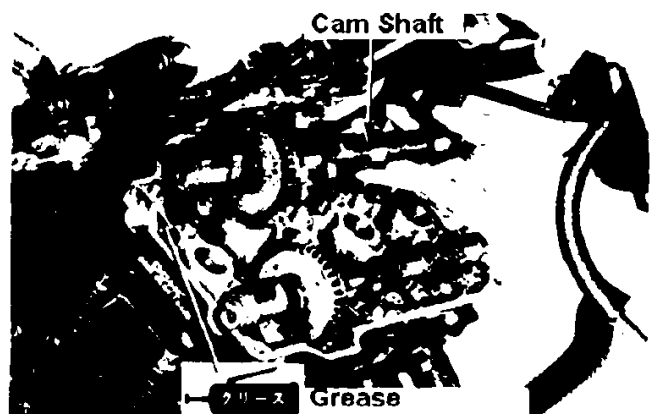

Place the cam shafts so as the two carved marks face each other and the lines are parallel to the cylinder head top surface.

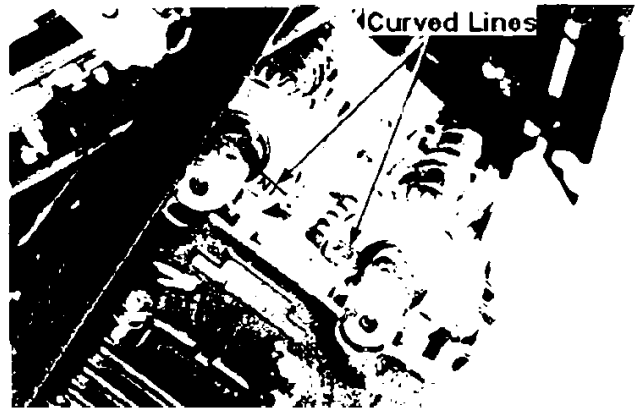

Apply grease on the journal or the cam shaft holder.  
Place it in it's original place.

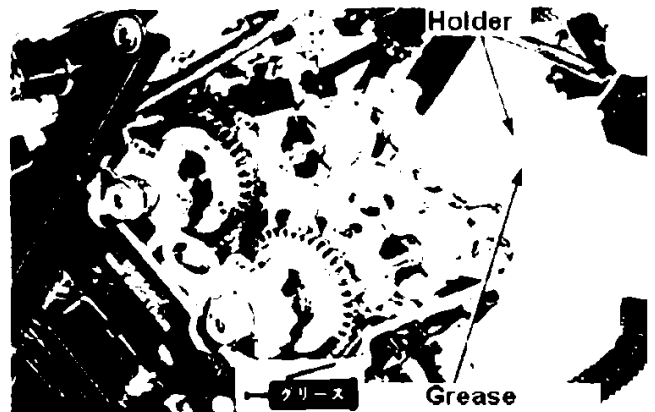

Attach a new O-Ring to the oil pipe and apply engine oil.  
Temporarily fix the oil pipe to the cylinder head with attachment bolts.

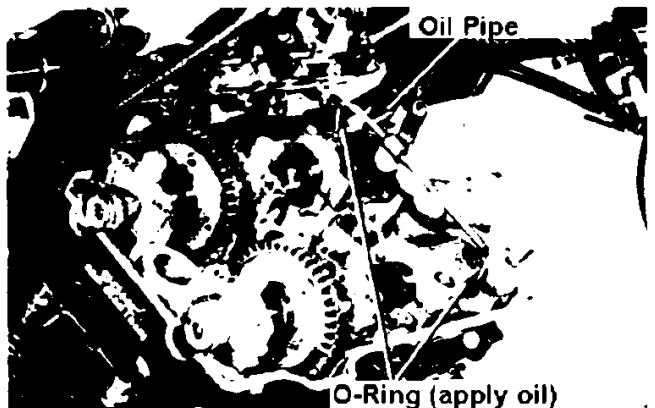

Evenly tighten the cam shaft holder attachment bolts in several steps.

Ensure the cam gear is matching

Torque: 1.2 ~ 1.6kg m

Apply locker (sealer) to oil pipe attachment bolts and tighten them up.



Ensure the "T" mark is aligned with the alignment mark.



Confirm that the "IN", "EX" marks face each other and they are parallel to the head top surface.

Adjust the tappet clearance (2 – 13)

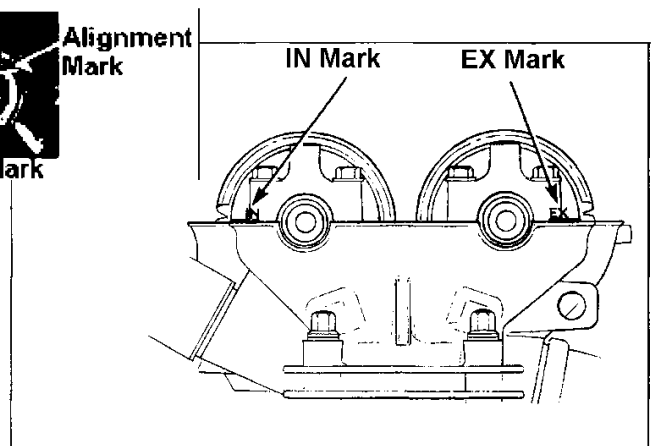

### Cylinder head cover attachment

Apply screw locker to the attachment bolts when tightening if the breather separate place has been removed.

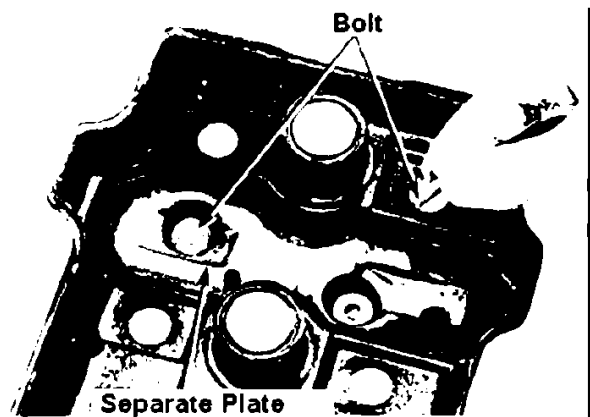

Attach the cylinder head cover gasket to the head cover.

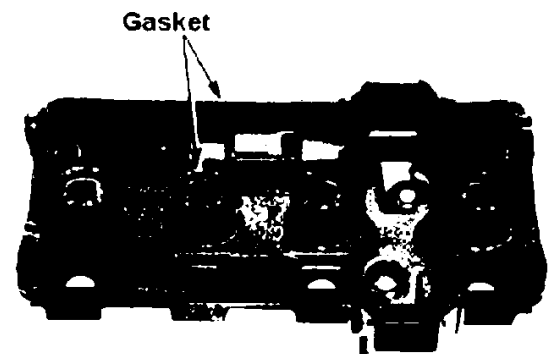

Attach the cylinder head cover to the cylinder head.

Be aware of "UP" mark on washers.

Apply washer and tighten the attachment bolts.  
Torque: 0.8 ~ 1.2kg m  
Connect the breather tube to the cylinder head cover.  
Attach the radiator holder to the cylinder head.

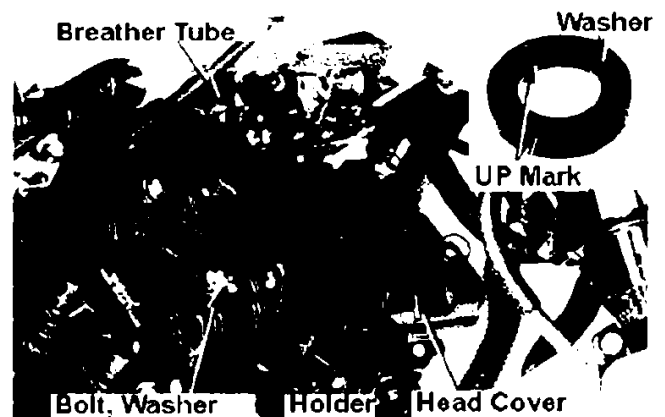

Attach the spark plug caps.

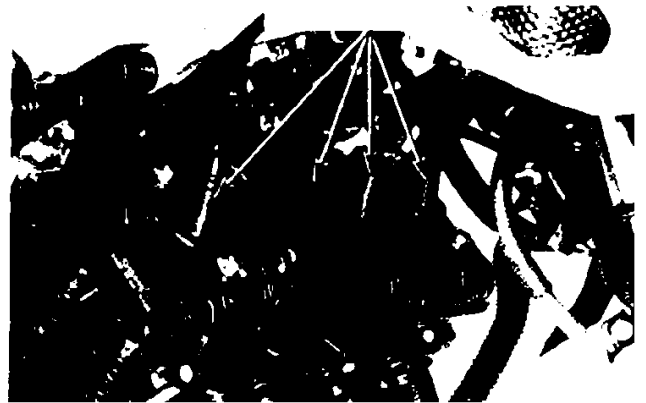

Fix the radiator to the lower holder on the cylinder head with the set pin.

Attach the side cowl.

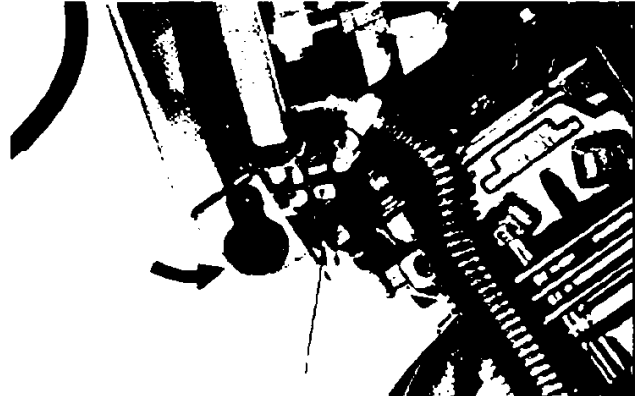

• Assembly

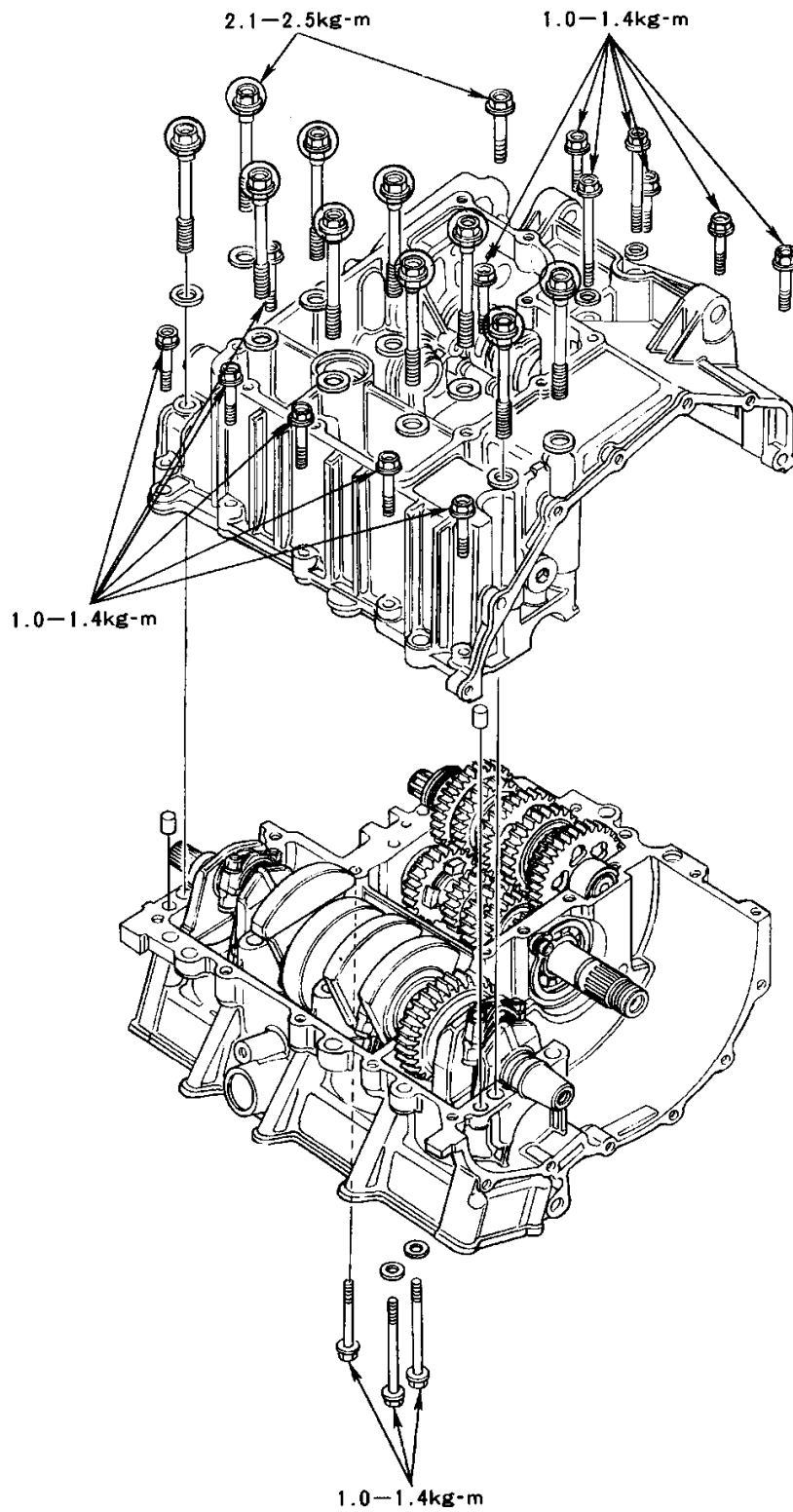

Assembly	8 - 0	Replacing bearings	8 - 3
Maintenance Information	8 - 1	Crank case assembly	8 - 3
Separating the crankcase	8 - 2		

## Maintenance Information

### General caution

- Service the crankshaft, conrod, cylinder, piston and transmission (including shift fork drum) after separating the crankcase.
- The following parts should be detached before separating the crankcase.
- Procedures / photos in this section are after the detachment.

Parts to be serviced	Parts to be detached
Conrod, cylinder block, piston	Cam shaft (Sec.7), Clutch outer (Sec.10), Oil pump (Sec.3)
Crankshaft	Fly wheel (Sec.10), Starter clutch (Sec.19), Camshaft (Sec.7), Oil pump (Sec.3)
Transmission	Clutch (Sec.10), gear shift linkage (Sec.11), Oil pump (Sec.3)
The main shaft and the counter shaft can be serviced without disconnecting the linkage.	

### **Torque**

8mm Bolt		2.1 – 2.5kg m
Crankcase	6mm	1.0 – 1.4kg m

### **Tools**

Exclusive		Common	
Bearing remover	07936-3710300	37x40mm	07746-0010200
Remover handle	07936-3710100	(17mm)	07746-0040400
Remover sliding weight	07741-0010201	Driver handle A	07749-0010000
		Outer driver (37 x 40mm)	07746-0010200
		Pilot (17mm)	07746-0040400

### Separating the crankcase

Detach the items specified in the maintenance information (8-1)

Remove the cylinder block tightening bolt.

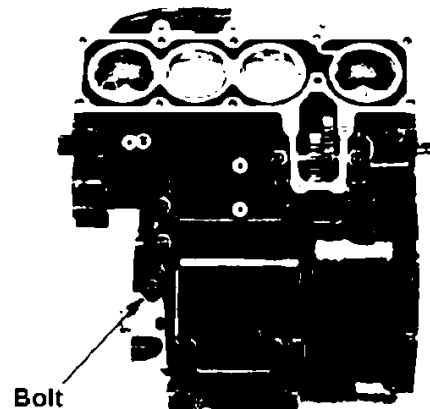

Face the cylinder head side downwards and remove the lower crankcase bolt.

Loosen the bolts in opposite angles so as to avoid distortion. Split into 2~3 sequences.

Detach the lower crankcase.

**CAUTION:**  
Do not insert a screwdriver to the contact slit.

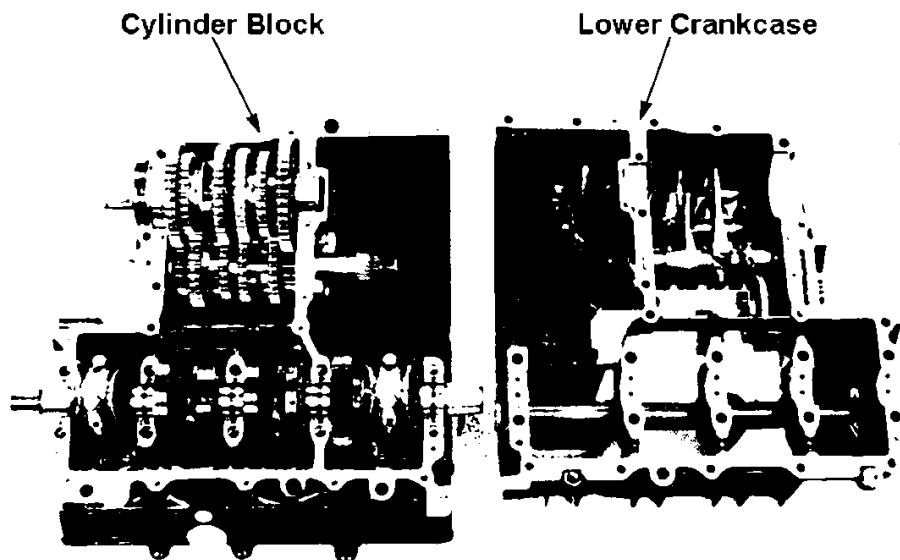
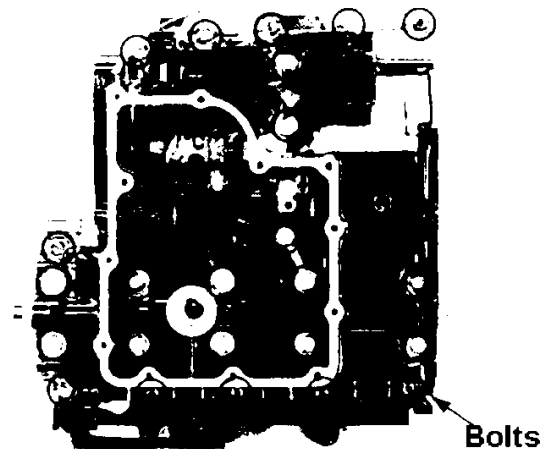

### Replacing bearings

Detach the following items from the cylinder block.

- Crankshaft (9-3)
- Piston (9-3)
- Counter shaft (12-3)
- Main shaft (12-3)

Replace the main shaft bearing if it fails to rotate smoothly.

Remove the bearing.

**Excl. tools**

Bearing remover	07936-3710300
Remover handle	3710100
Remover sliding weight	07741-0010201

### Install new bearing

**Common Tools**

Driver handle A	07749-0010000
Outer driver (37 x 40mm)	07746-0010200
Pilot (17mm)	07746-0040400

Insert the bearing horizontally.  
Face the marked side downward.

Attach the following parts to the cylinder block.

- piston (9-9)
- crankshaft ((9-9)
- main shaft (12-7)
- counter shaft (12-7)

### Crank case assembly

Clean the crankcase contact surface.  
Attach the knock pin and oil orifice.  
Apply liquid sealer to the contact surfaces on the cylinder block and a lower crankcase.

- Do not apply near the main bearing.
  - Ensure the orifice is not jammed.
  - Face the larger hole outward.

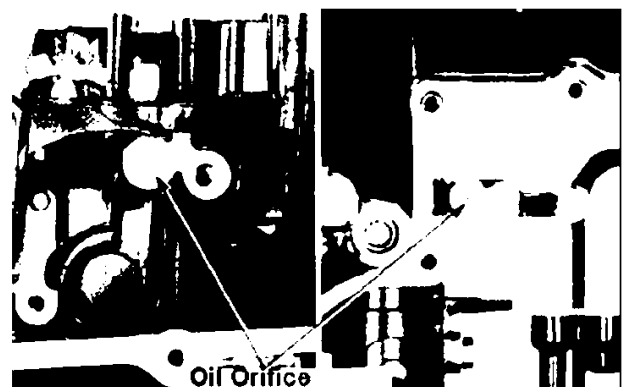
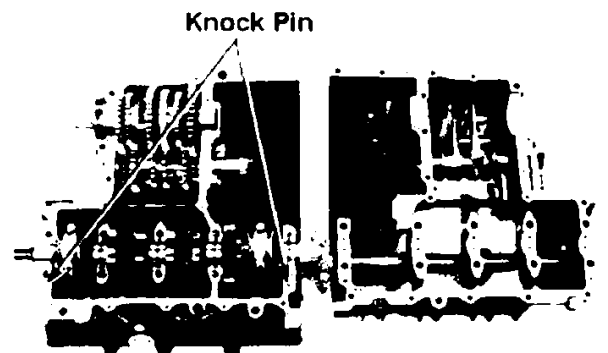
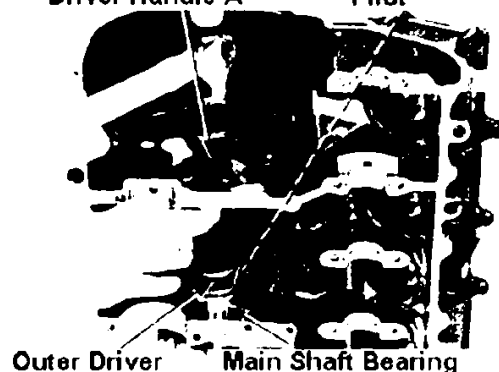
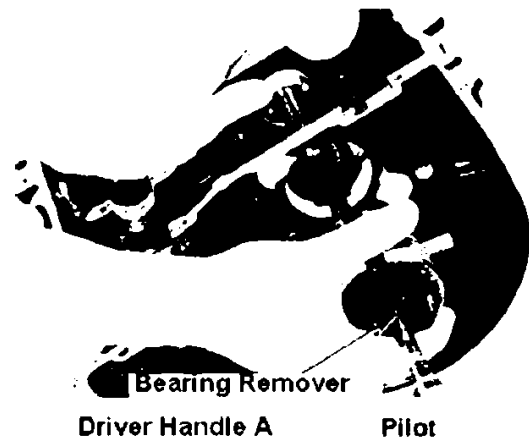



Do not apply the sealer near the oil passage.

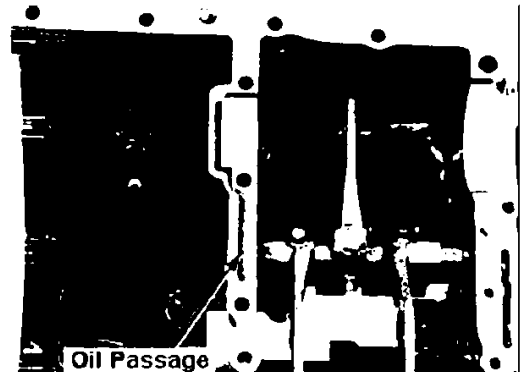

Set the transmission gear to neutral.  
Align the shift fork to the gear slit and attach the two crankcases.

Ensure there is no slit along the contact surfaces.

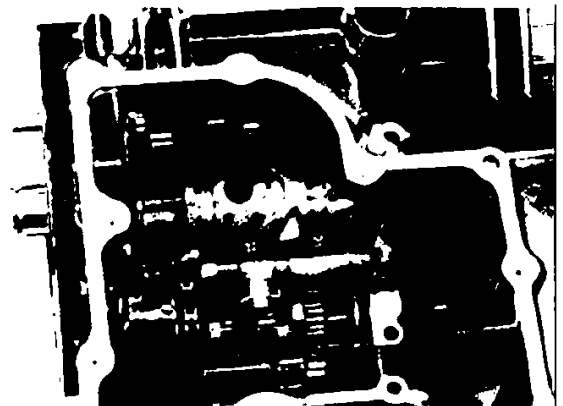

Tighten the lower crankcase bolts in the following order.

Do not tighten in one step.

Torque: 8mm bolt → 2.1 ~ 2.5kg m  
1-2-3-4-5-6-7-8-9-10 – with washers  
21 – without washers

6mm bolt → 1.0 ~ 1.4kg m  
11-12-13-14-15-16-17-18-19-20-22-23-24

- Place the sealing washers to the 6mm bolts specified as 12-13.
- Apply engine oil to the thread and flange on 8mm bolts before tightening.

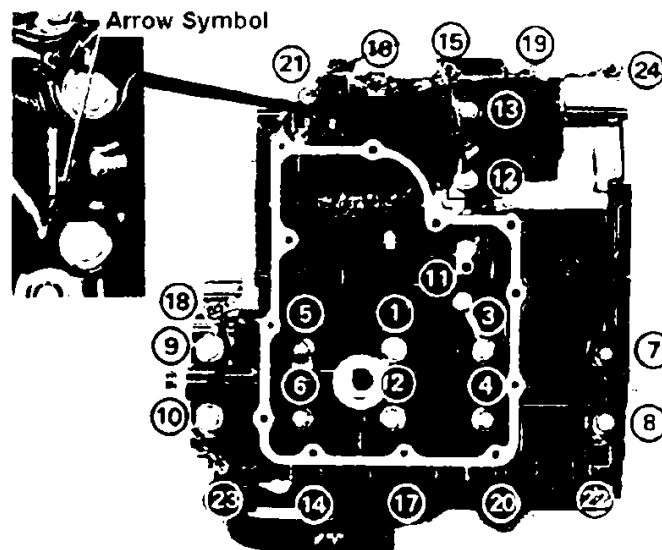

Tighten the cylinder block bolt to specified torque.  
(Torque: 1.0 ~ 1.4kg m)

Re-attach the detached items

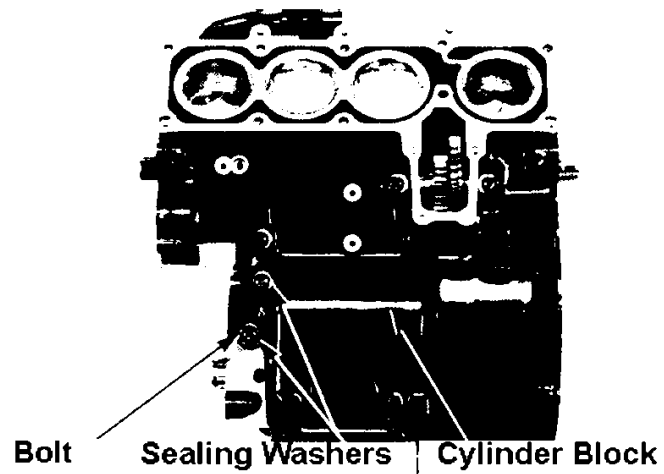

• Assembly

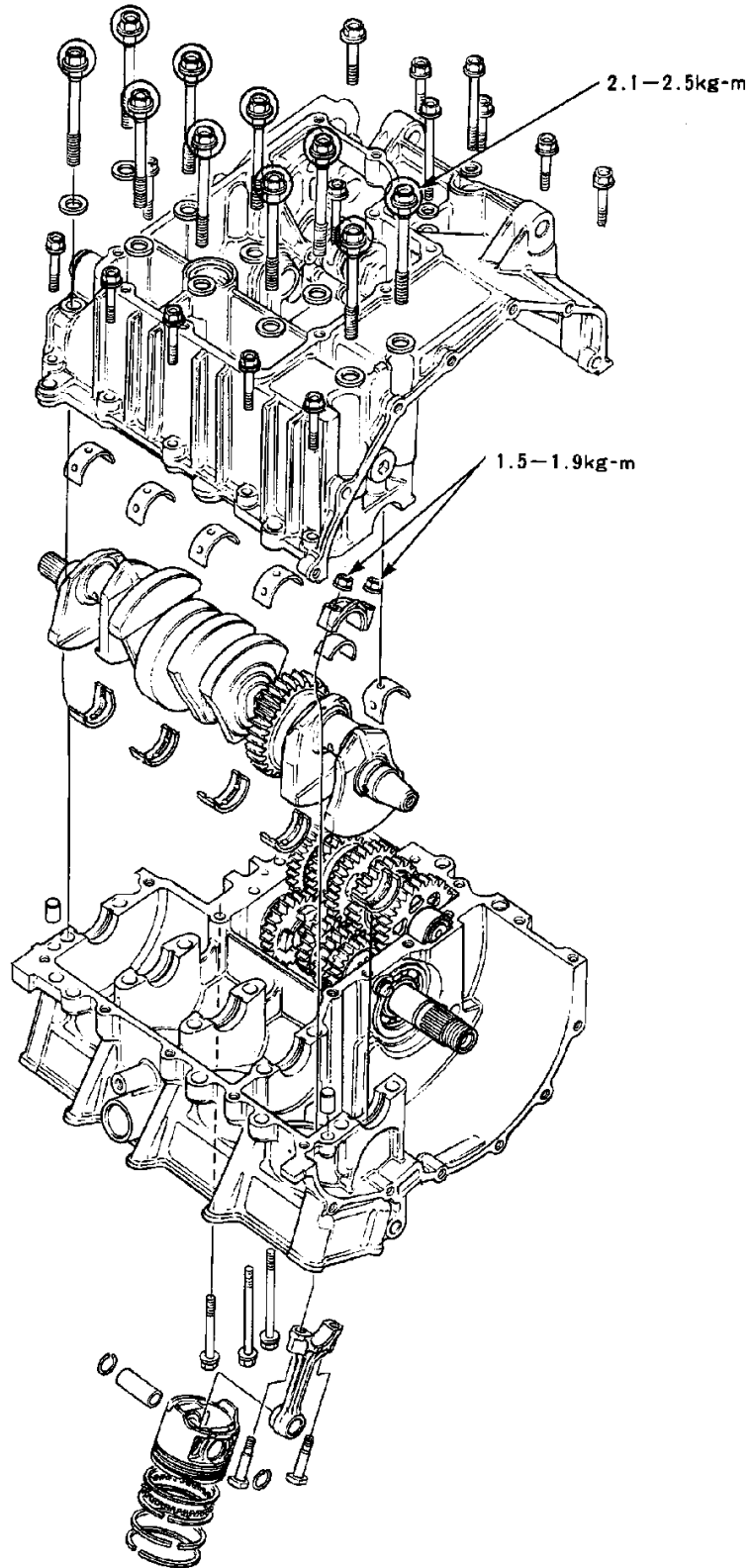

Assembly	9-0	Bearing inspection/selection	9-6
Maintenance Information	9-1	Attachment	9-9
Troubleshooting	9-2	Piston Installation	9-10
Crankshaft removal/Inspection	9-3		

**CAUTION**

- Select the proper crank pin and main journal from the coloured code. Select replacement bearings from the code table.
- After replacing the bearings, check the oil clearance with a plastic gauge.
- Apply MoS<sup>2</sup> and grease on main journal bearing and conrod bearings on assembly.
- Remove carbon and sludge on the cylinder before removing the piston and the conrod.
- Maintenance of piston, conrod and crankshaft should be done after disassembly of the crankcase.

Item		Standard	Limit	
Crankshaft	Conrod side clearance (edge)	0.05-0.2	0.30	
	Crankshaft deviation	-	0.05	
	Crank pin oil clearance	0.020-0.044	0.05	
Conrod	Main journal oil clearance	0.021-0.054	0.06	
Cylinder	Internal diameter	48.500-48.510	48.60	
	Upper surface distortion	-	0.05	
	Circular distortion	-	0.005	
	Cylindrical distortion	-	0.005	
Piston Ring	Ring and ring slit clearance	Top	0.015-0.050	0.10
		Second	0.015-0.050	0.10
	Ring alignment slit clearance	Top	0.1-0.25	0.45
		Second	0.1-0.3	0.50
		Oil (side rail)	0.2-0.8	1.00
Piston	Piston external diameter	48.47-48.49	48.35	
	Piston and cylinder clearance	0.01-0.04	0.10	
	Piston pin hole diameter	13.002-13.008	13.02	
	Piston pin external diameter	12.994-13.000	12.98	
	Piston and piston pin clearance	0.002-0.014	0.04	
	Conrod edge internal diameter	13.016-13.034	13.05	
	Piston pin and conrod clearance	0.016-0.040	0.06	

**Tightening Torque**

1.5 ~ 1.9kg m  
2.1 ~ 2.5kg m

Conrod bearing cap nut  
Crankcase attachment 8mm bolt

**Tools**

Exclusive Tool      07955-ZG00000      Piston ring compressor

**Troubleshooting****Engine Noise**

- Main journal bearing worn out
- Crank pin bearing worn out
- Piston, cylinder worn out
- Piston pin, piston pin hole, conrod little end worn out
- Piston ring worn out / stuck/ damaged.

**Low compression, failure to start, rough idling**

- Piston ring worn out / stuck / damaged
- Cylinder, piston worn out / damaged

**High Compression**

- Carbon on the cylinder head or piston top

**Overheat**

- Carbon on piston top
- Blocked cooling system

**Smoke from a muffler**

- Cylinder, piston, piston ring worn out
- Inadequate installation of the piston ring
- Piston / cylinder damaged

### Removal of the piston, conrod and crankshaft

Separate the crankcase (8-2)

Remove the counter shaft (12-3)

Inspect the conrod side clearance

More than 0.30mm → replace

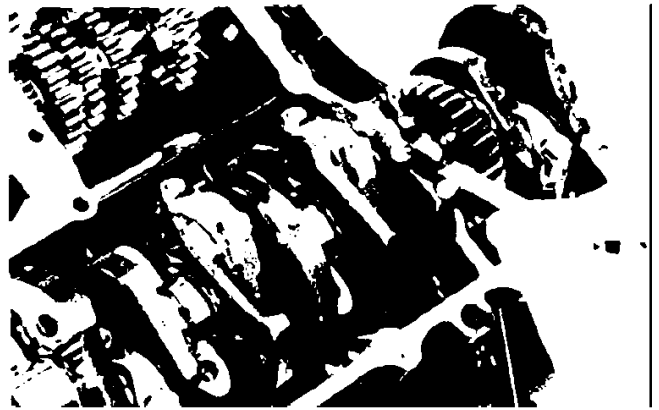

Remove the bearing cap nut and remove the bearing cap.

Push the piston and pull the piston and the conrod out.

Mark the removed parts so as to remember the original place.

Remove the crankshaft.

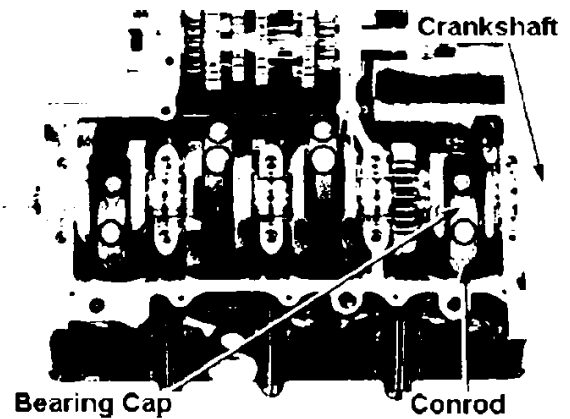

### Crankshaft inspection

Support both sides of the shaft and measure the displacement of the journal.

Greater than 0.05mm → replace

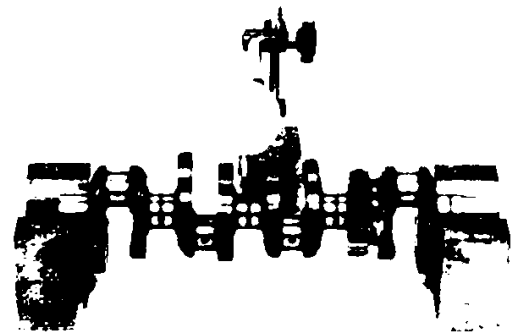

### Disassembly of piston

Remove the piston pin clip and pull out the piston pin.

Remove the piston from the conrod.

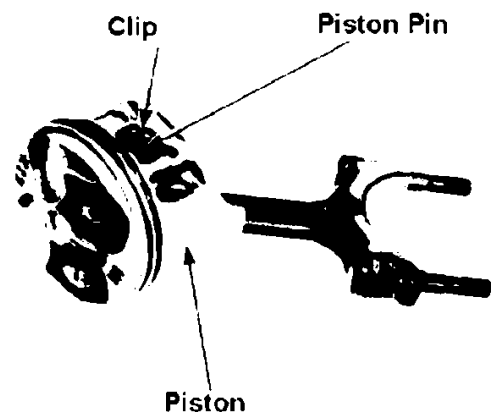

Remove the piston rings.

Separate rings for individual cylinders / pistons.

Remove sludge from the piston head.

Inspect the piston for scratch, crack, unequal ring groove and carbon.

Inspection of Piston, Piston ring, conrod

Measure the clearance between the piston ring and the groove.

Top  $\geq 0.10\text{mm}$  → replace

Second  $\geq 0.10\text{mm}$  → replace

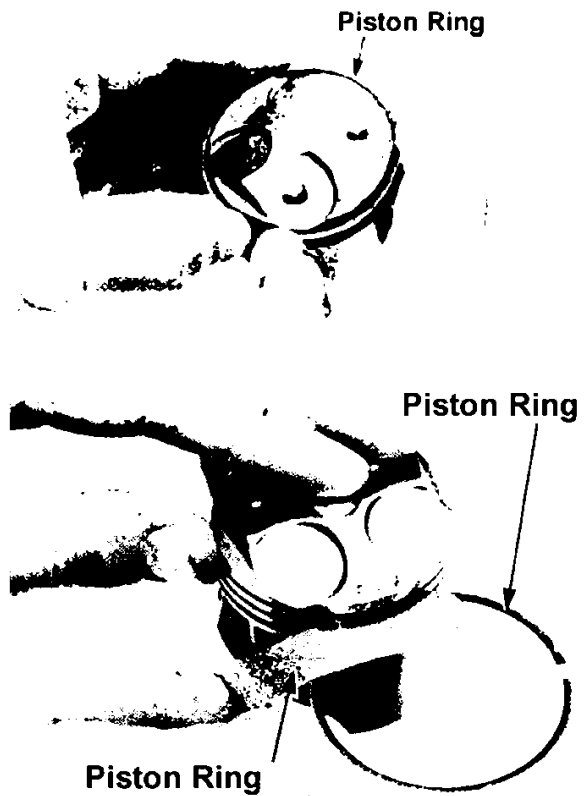

Attach each ring with piston head to the bottom of the cylinders so as to be horizontal.

Measure the clearance.

Top  $\geq 0.45\text{mm}$  )  
Second  $\geq 0.50\text{mm}$  ) Replace  
Oil (Side rail)  $\geq 1.00\text{mm}$  )

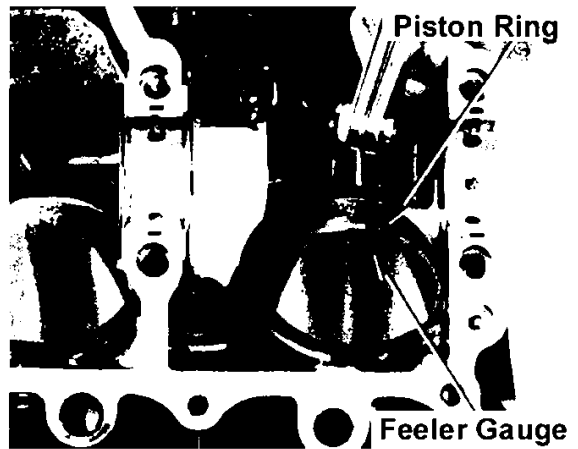

Measure the inner diameter of the piston pin hole.

Greater than 13.02mm → replace

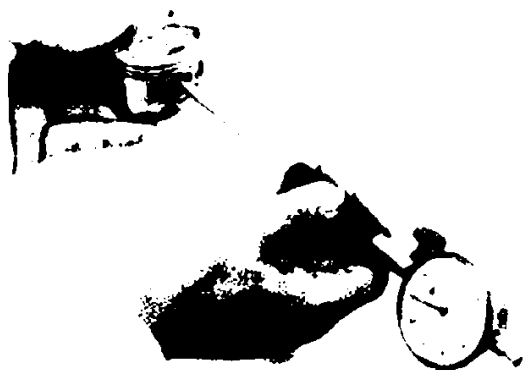

Measure the inner diameter of conrod little end.

Greater than 13.05mm → replace



Measure the outside diameter of the piston pin.

Smaller than 12.98mm → replace

Calculate the clearance between the piston and piston pin.

Greater than 0.06mm→replace



Measure the outside diameter of a piston

Measure at 14mm from the bottom end of the skirt and perpendicular to the piston pin hole.

Smaller than 48.35mm → replace



Cylinder Inspection

Measure the distortion of the cylinder top surface.

Greater than 0.05mm → Adjust or replace





Inspect the inner surface of the cylinder.  
 Measure the inner diameter for X – Y direction at upper, middle, lower part of the cylinder, and record the six numbers.  
 The maximum number is considered as an inner diameter.

Greater than 48.60mm → adjust or replace

Calculate the clearance between the cylinder and a piston by measuring the outside diameter of a piston. Take the maximum value.

Greater than 0.10mm → adjust or replace

Calculate the following parameters and take maximum number:

Circular distortion:

- = (X – direction diameter)
- = (Y – direction diameter)

Cylindrical distortion:

- = (Difference in X or Y direction Diameter between three parts).

**Both parameters should be  $\leq 0.05\text{mm}$**

**If greater → adjust / replace**

**Inspection / Selection of bearings**

Crank pin bearing

Inspect the bearing for scratch, or separation.  
 Wipe off the oil on the bearing and the crank pin.  
 Attach the crankshaft.  
 Avoid oil hole and apply plastic gauge.

Attach the conrod bearing caps to individual crank pins and tighten the bolts.  
 Tightening Torque: 1.5 ~ 1.9kg m

Ensure the crankshaft and conrod do not rotate while measuring.

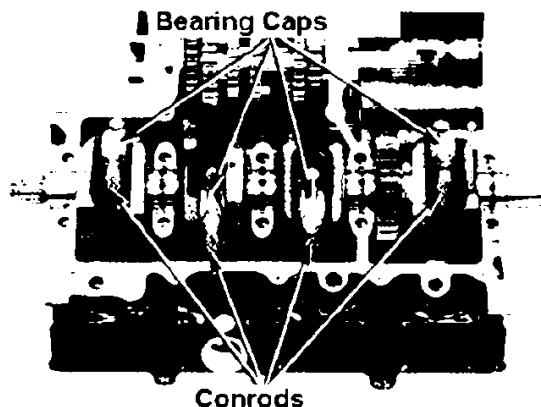
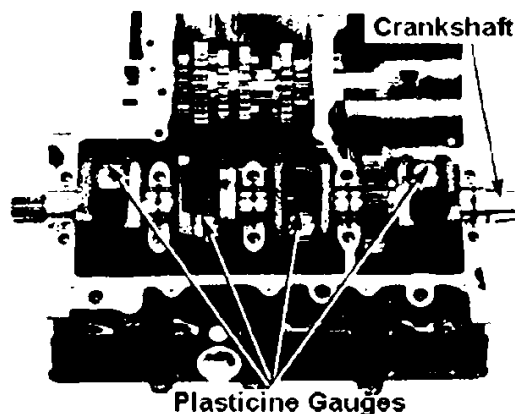
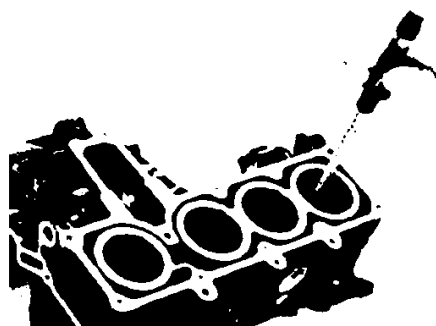

Remove the bearing cap and measure the width of plasticine gauges.

Oil clearance  $\geq 0.05\text{mm}$  → replace

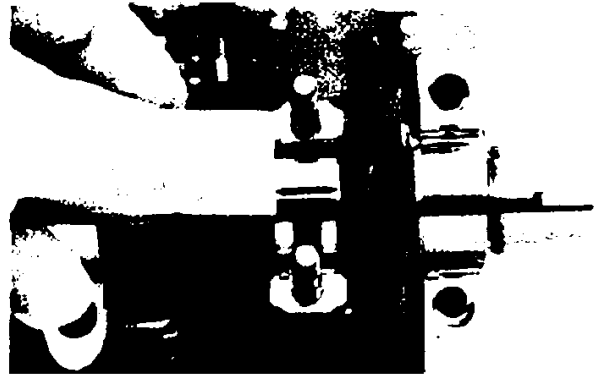

If the oil clearance is beyond the limit, replace the bearing.

Follow the procedure for bearing selection. Record the conrod internal diameter code number.

The 2 mark on the conrod is the internal diameter code number.



**Internal Diameter Code**

Record the crank pin external diameter code number (or measure it).

A or B on the crank weight is the code.



**External Diameter Code**

From the crankpin and conrod code numbers, find the colour code for the bearing.

**Colour Code**

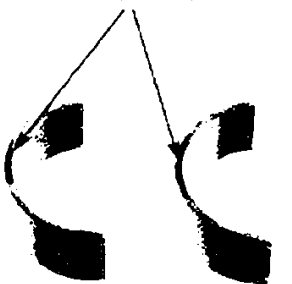

**Bearing Metal Thickness**  
 A (Brown): 1.502~1.506mm  
 B (Green): 1.498~1.502mm  
 C (Yellow): 1.494~1.498mm

			Conrod Internal Dia code	
			1	2
Crank pin external diameter code	A	26.992 ~27.000mm	30.000 ~30.00mm	30.008 ~30.016mm
	B	26.984 ~26.992mm	C (Yellow)	B (Green)
			B (Green)	A (Brown)

Main Bearing

Inspect for scratch or separation.

Wipe the oil off on the bearing and journal surface.  
Place the plastic gauges avoiding the oil holes.

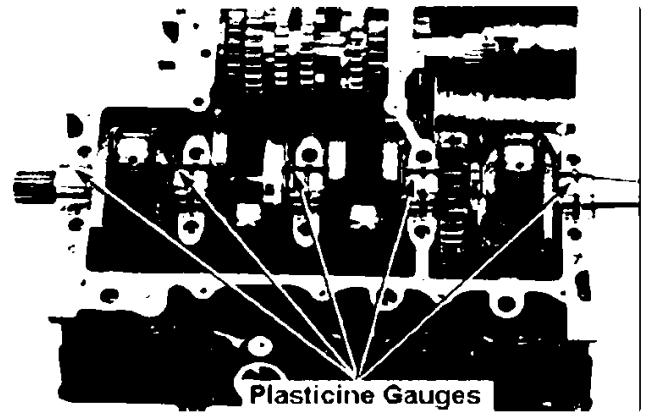

Attach the lower crankcase and fix with 8mm attachment bolts (x10).

Tightening torque: 2.1 ~ 2.5kg m

Ensure the crankshaft will not turn while measuring.

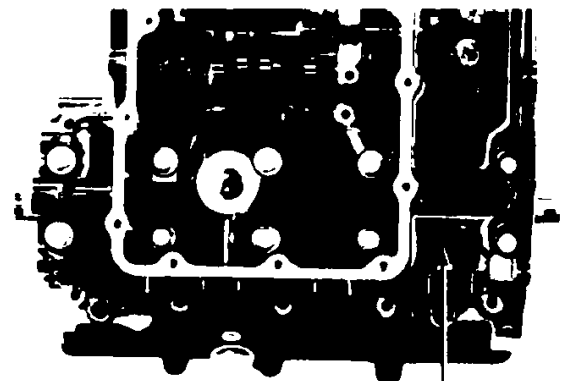

Lower Crankcase

Remove the lower crankcase and measure the width of the plasticine gauges.

Oil clearance  $\geq 0.06\text{mm}$  → replace

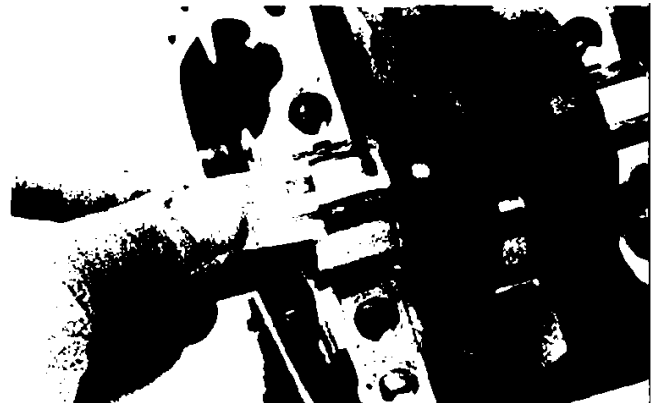

Record the crankcase internal diameter code.

The A, B or C mark on the rear part of the upper crankcase.

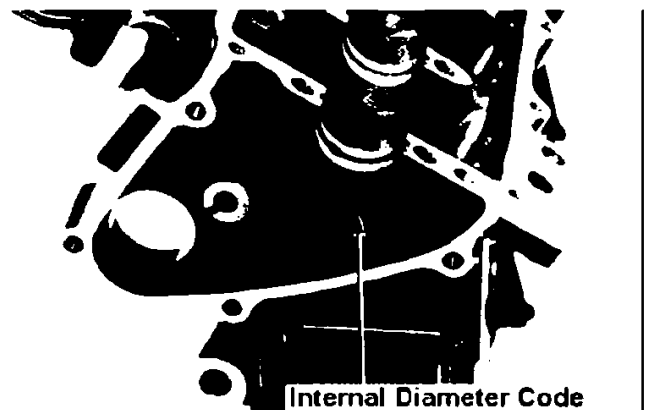

Internal Diameter Code

Record the crankshaft main journal external diameter code (or measure it).

The symbol 1,2 on the crankweight

Find out the corresponding bearing colour code from the crankcase and the crankshaft code numbers.



**External Diameter Code**

Bearing metal thickness

A	1.507 – 1.511mm	Brown
B	1.503 – 1.507mm	Green
C	1.499 – 1.503mm	Yellow
D	1.495 – 1.499mm	Pink



**Colour Code**

			Case Internal Diameter Code		
			A	B	C
Main journal external diameter code	1	27.992-28.000mm	D (Pink)	C (Yellow)	B (Green)
	2	27.984 – 27.992mm	C (Yellow)	B (Green)	A (Brown)

**Piston, conrod, crankshaft attachment**

Attach the main bearing to the cylinder block, lower crankcase.

Apply MoS<sup>2</sup> Grease on the main bearing surface.

Align the key on the bearing to the key slit on the cylinder block and lower crankcase.

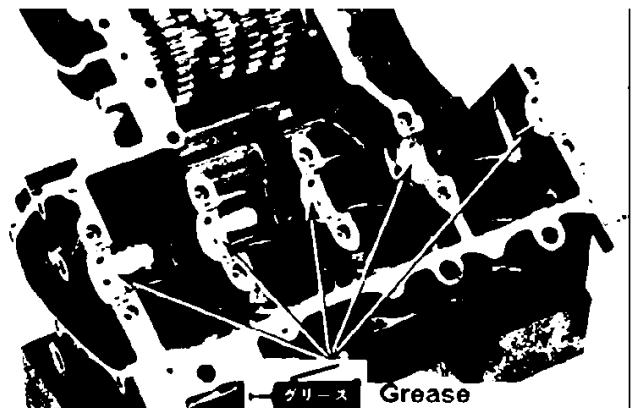

**Piston Ring**

Remove the carbon on the piston head and ring slits.

Attach the piston rings.

- Exercise caution not to damage the piston or the ring.
- Marked face on the ring should face up.
- Ensure 120° offset between the alignment slit.
- Avoid attaching the ring on piston pin hole direction and perpendicular to the pin.
- Offset the alignment slits on side rails to left and right.
- After attaching the rings, confirm the smooth movement of the rings.

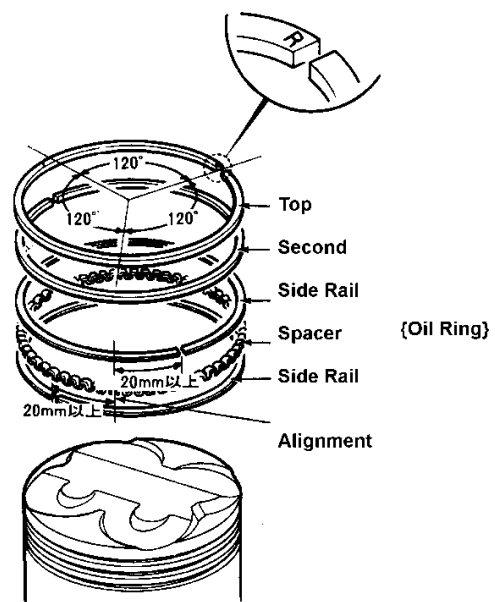
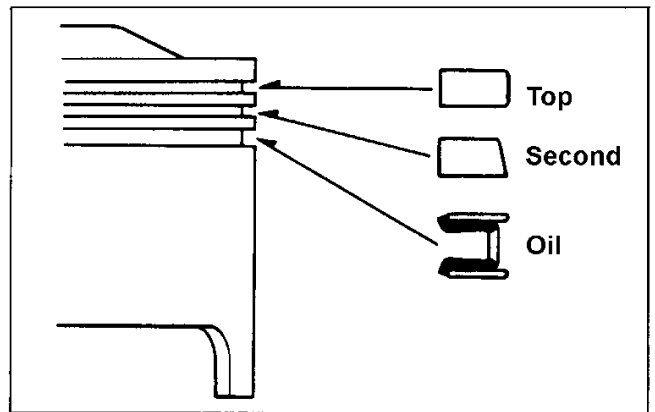

**Assembly of the piston and the conrod**

Attach the bearing to the conrod and bearing cap.

- Align the key on the bearing to the key slit on the conrod and bearing cap.
- Apply MoS<sup>2</sup> Grease on the bearing surface.

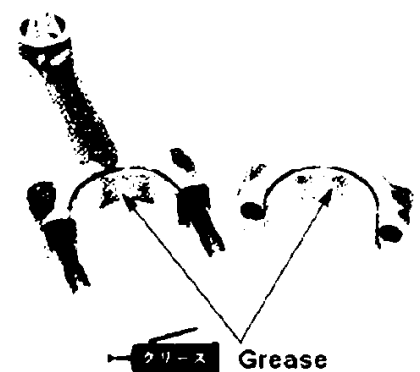

Apply oil to the conrod little end, piston pin external surface and piston pin hole surface.  
 Attach the piston to the conrod.  
 Attach the piston pin and set the piston pin clip to the piston slit firmly.

- Face the IN mark on the piston to the slit on the conrod.
- Align the marks which were made on disassembly

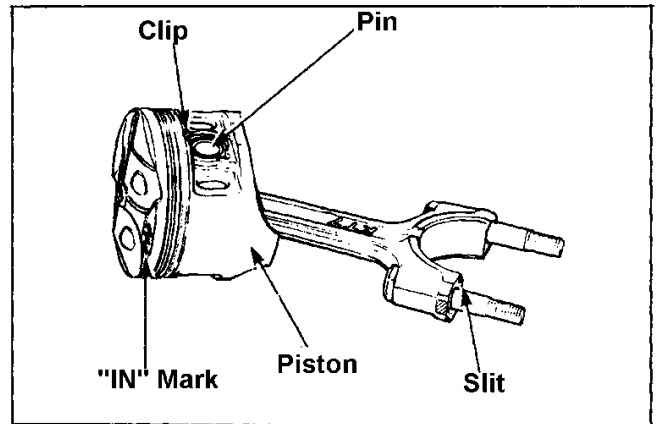

**Attachment of the piston and the conrod**

Apply oil on external surface of the piston.  
 Insert the conrod and piston to the top of the cylinder on the crankcase.  
 Compress the piston ring by using a piston ring compressor and insert the piston to the cylinder by lightly pushing the piston head.

Beware of damaging the piston and piston ring

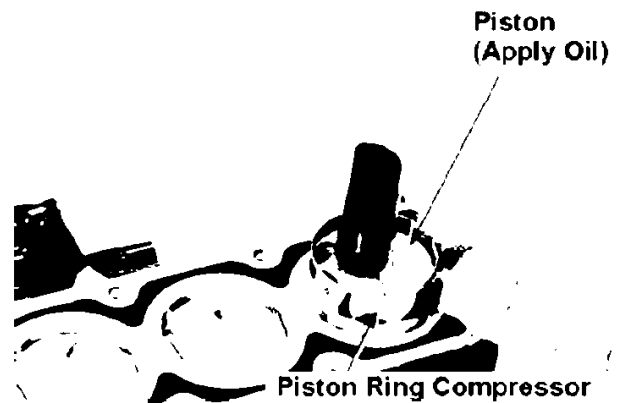

**Exclusive tool:**

Piston ring compressor 07955 – ZG0000

Confirm the IN marks are facing towards the intake side.

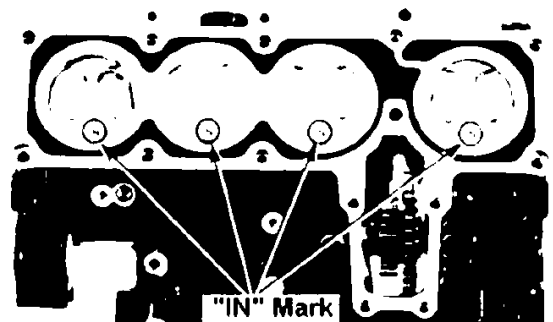

**Attachment of the crankshaft**

Apply MoS<sup>2</sup> grease to the journal of the crankshaft and the crankpin and attach to the cylinder block.

In order to avoid damaging the crankshaft with the conrod, align the larger edge of the conrod to the crankpin.

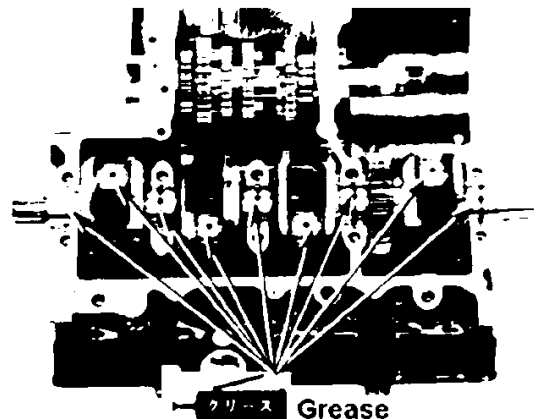

Attach the conrod bearing cap.

Ensure the bearing cap is attached in the direction the same as before disassembly.

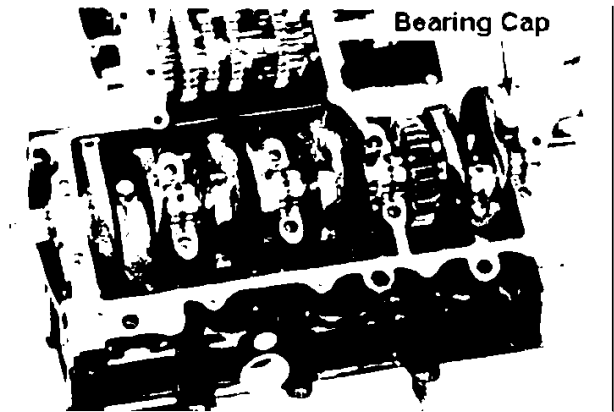

Attach cap nuts and tighten.  
Tightening Torque: 1.5 ~ 1.9 kg m

Tighten the nuts in parallel so as to have equal torque among the nuts.

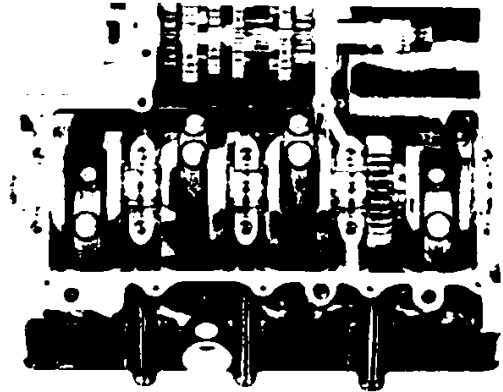

After tightening the nuts, confirm the smooth movement of the conrods by rotating the crankshaft.

• Assembly

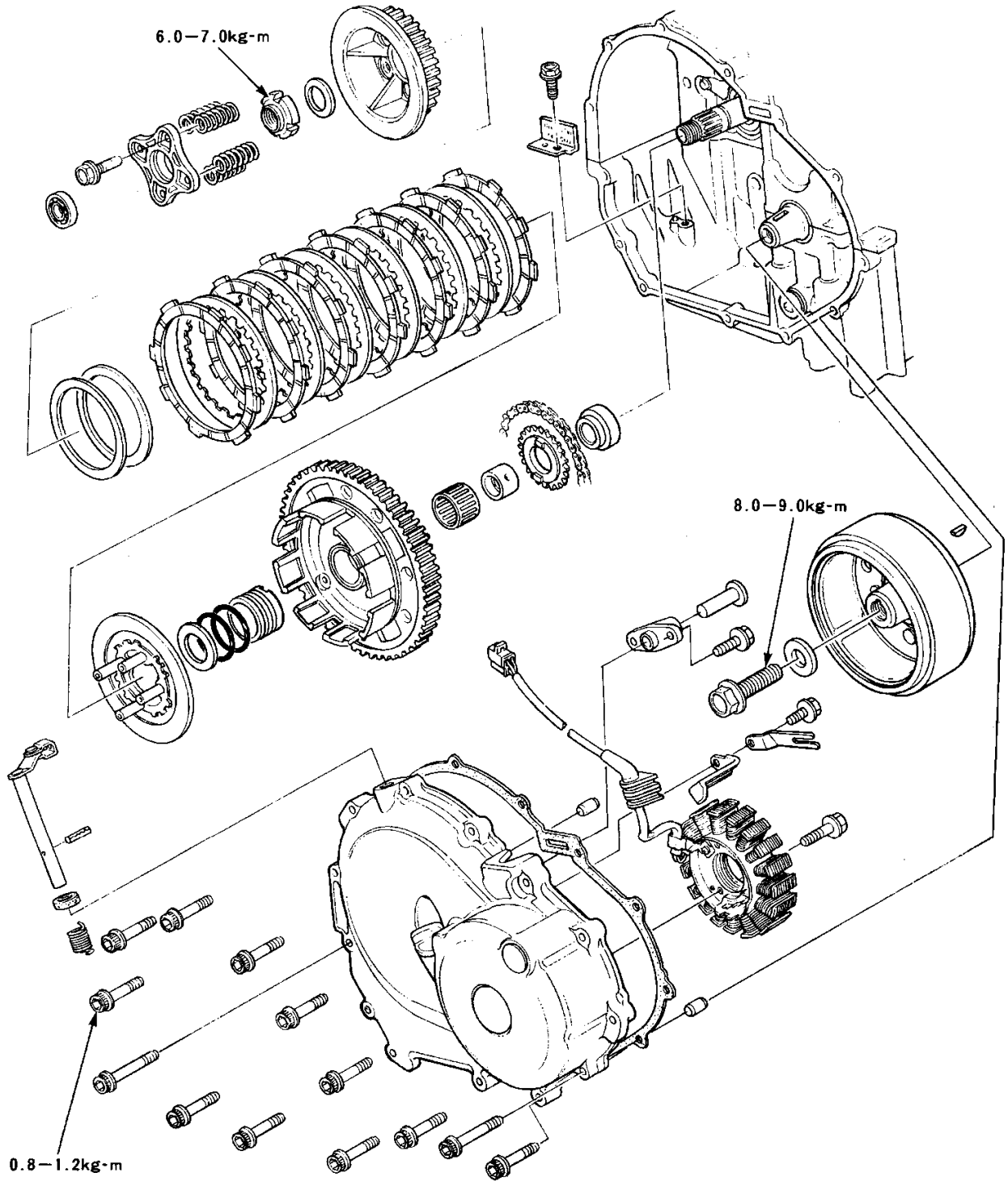



Assembly	10-0	AC Generator detachment	10-4
Maintenance Information	10-1	Clutch	10-5
Troubleshooting	10-2	AC Generator attachment	10-12
Right crankcase cover detachment	10-3		

- Engine detachment is not required for the works in this chapter.
- Remove gasket materials on the attachment surfaces of the case.
- Keep the engine away from debris / mud.
- Do not damage the attachment surface when disassembling.
- AC generator troubleshooting (→ Sec. 17,18)
- Refer to 1-27 for AC generator total system troubleshooting.

### Standard

Item		Standard	Limitation
Clutch	Free movement of the clutch lever	10-20	-
	Clutch spring resting length	34.79	33.79
	Clutch disk thickness	2.9-3.0	2.6
	Clutch plate distortion	-	0.3
	Clutch out guide inner diameter	21.995-22.015	22.03
Oil pump drive sprocket inner diameter		30.025-30.075	30.09
Oil pump drive gear collar	Inner dia	21.995-22.015	22.03
	Outer dia	29.987-30.000	29.97
	Height	22.300-22.400	22.20
Main shaft outer dia (clutch outer guide contact area)		21.980-21.990	21.97

### Torque

Oil pump driven sprocket bolt	1.3-1.7kg m	apply screw locking fluid
Clutch lock nut	6.0-7.0kg m	
Flywheel bolt	8.0-9.0kg m	
Right crankcase cover bolt	0.8-1.2kg m	

### Tools

#### **Exclusive Tools**

Clutch centre holder                      07GMB – KT70100

#### **Common tools**

Flywheel holder	07725 - 0040000
Rotor puller	07733 - 0020001
Lock nut wrench (26x30mm)	07716 - 0020203
Extension Bar	07716 - 0020500

**Clutch, AC Generator****Troubleshooting**

Majority of the clutch troubles, come from inadequate free movement of the clutch lever. Inspect and adjust this before disassembling the clutch.

**The clutch slips when accelerating**

- Too small free movement of the lever.
- Clutch disks worn out.
- Clutch springs weak/sagged.

**Unable to part the clutch**

- Too much free movement of the lever.
- Distorted / bent clutch plate.

**Unstable clutch movement**

- Clutch outer slit worn out.

**The lever is stiff**

- Clutch cable damaged or clogged with mud.
- Lifter mechanism failure.
- The cable is not going through the proper places.

## Crankcase detachment

- Drain engine oil (2-16)
- Detach the seat
- Remove the side cover
- Remove regulator / rectifier attachment nuts.

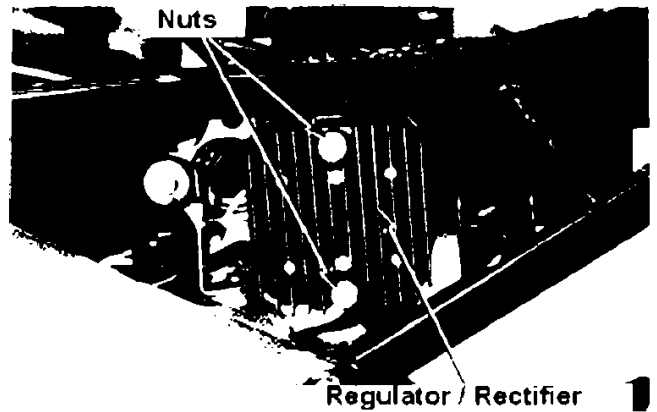

- Disconnect the 3P coupler on the regulator / rectifier.

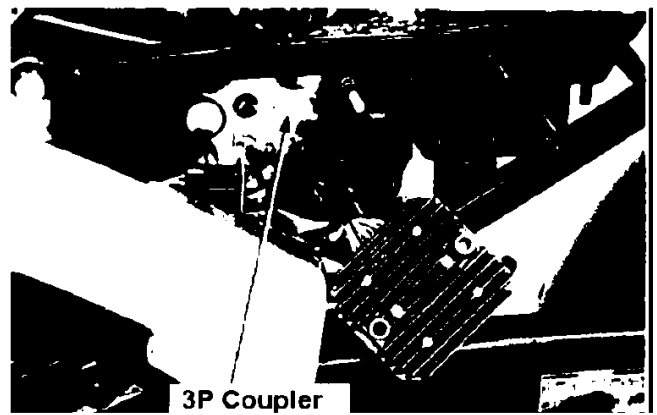

- Loosen the clutch cable adjust nut and lock nut.
- Remove the clutch cable.

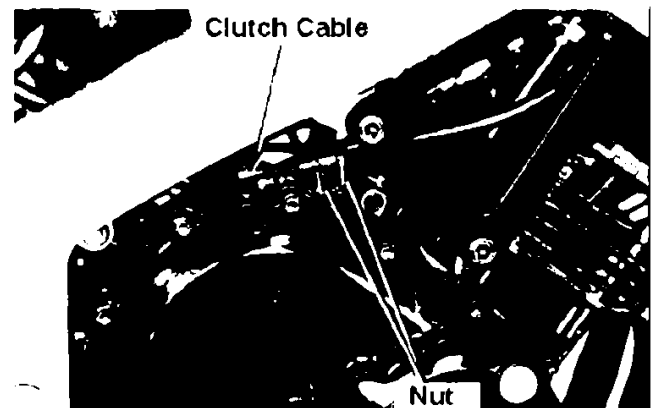

- Remove the right crankcase cover attachment bolts and detach the crankcase cover.

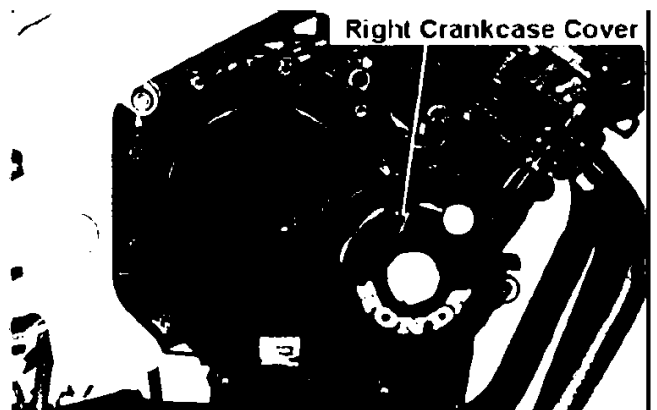

Remove gasket and knock pins.

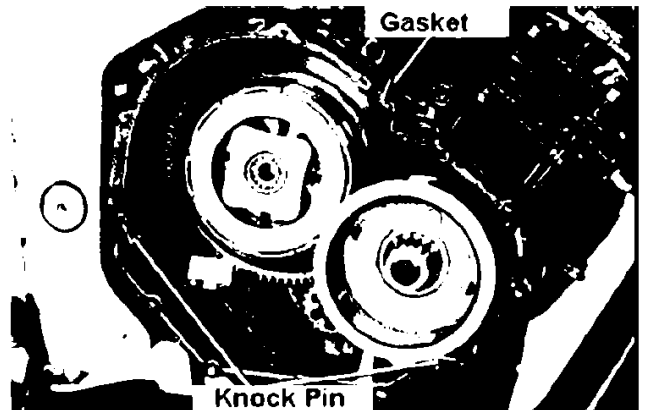

### Inspection of the clutch lifter

Remove the lifter pin and the spring.  
Remove the spring stopper and detach the clutch lifter arm.  
Inspect the lifter pin and the clutch lifter arm for damage.  
Inspect the spring for stretch.

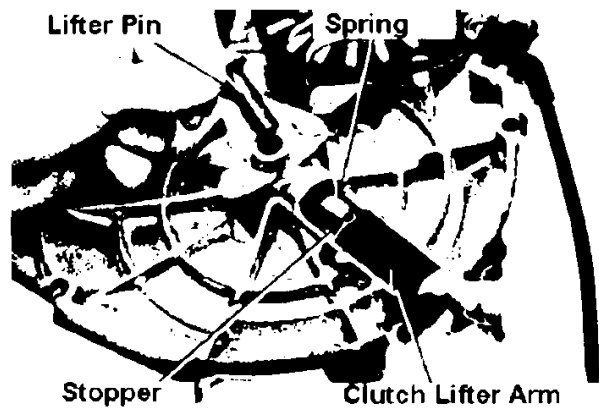

Inspect the needle bearing for wear, damage and loose attachment. Inspect the oil seal for wear and deformation.

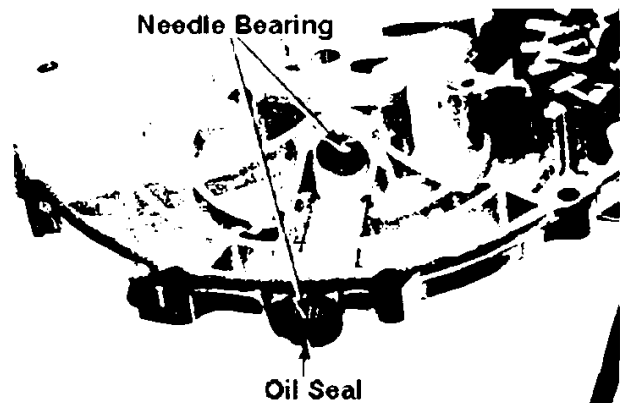

### AC Generator Detachment

Remove the grommet.  
Remove the AC Generator wire clamp.  
Remove the stator attachment bolt and detach the stator from the right crankcase cover.

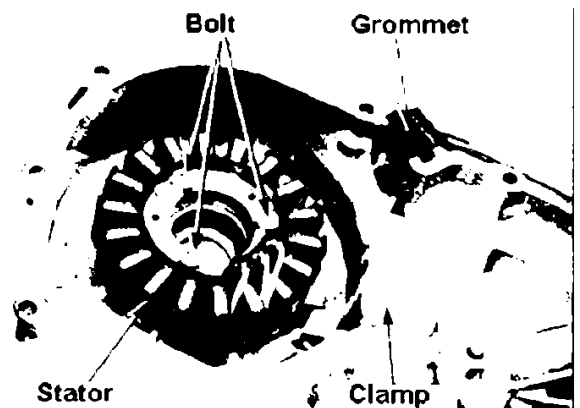

Fix the flywheel with a flywheel holder and remove the bolt.

**Common Tool:**  
Flywheel holder 07725-0040000

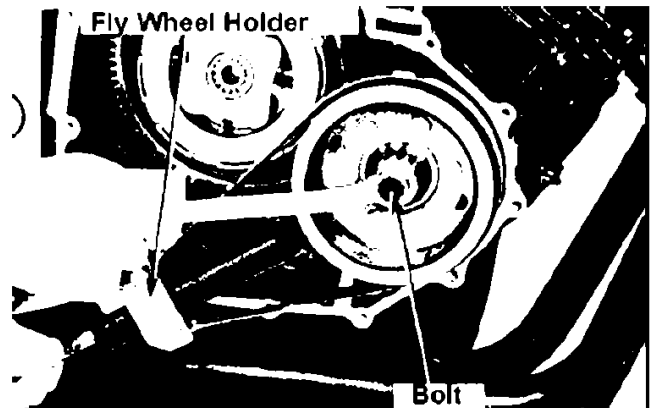

Use a rotor puller to detach the flywheel.

**Common Tool:**  
Rotor puller 07733-0020001

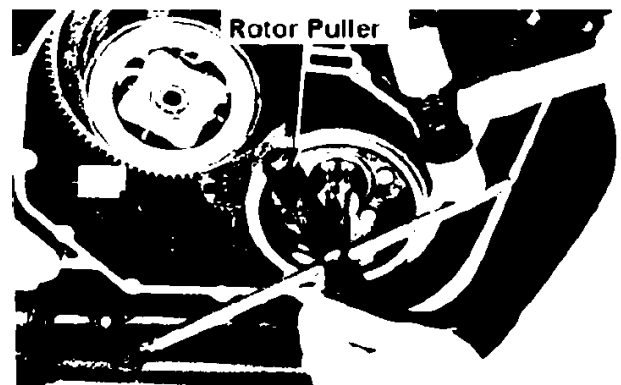

Remove the wood ruff key from the crankshaft.

Do not lose the woodruff key

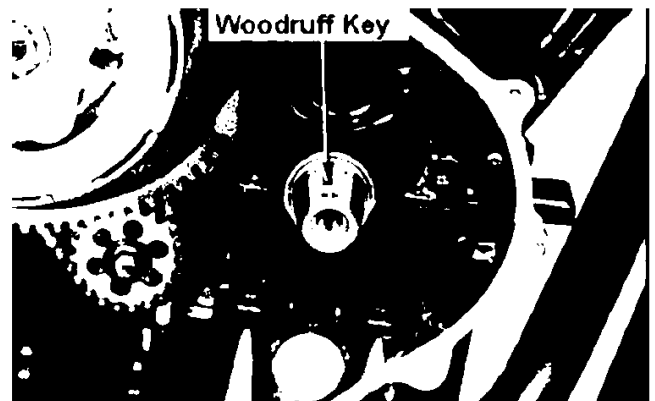

## Clutch

Detachment

Detach the right crankcase cover (10-3).  
Remove bolts and detach the clutch lifter plate and clutch springs.

Loosen the clutch lifter attachment bolts by each opposite corner.

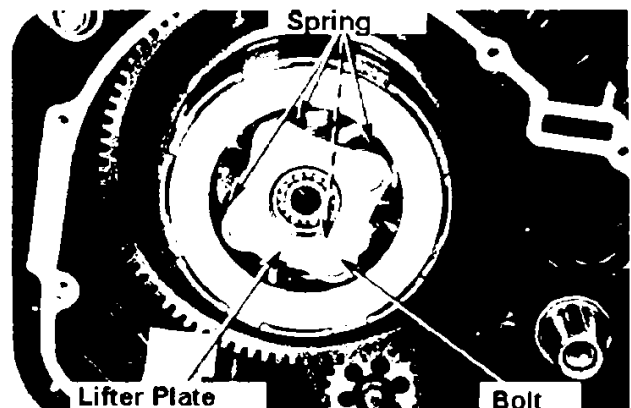

Fix the clutch with the clutch centre holder and remove the clutch centre lock nut.

**Exclusive Tool:**

Clutch centre holder 07GMB-KT0100

**Common Tool:**

Lock nut wrench (26 x 30mm)

07716-0020203

Extension bar

07716-0020500

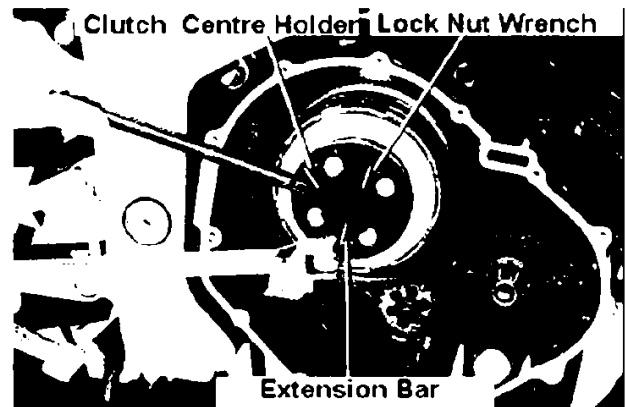

Detach the clutch centre holder. Detach the lock washer, clutch centre, shudder spring, disc, plate and the pressure plate.

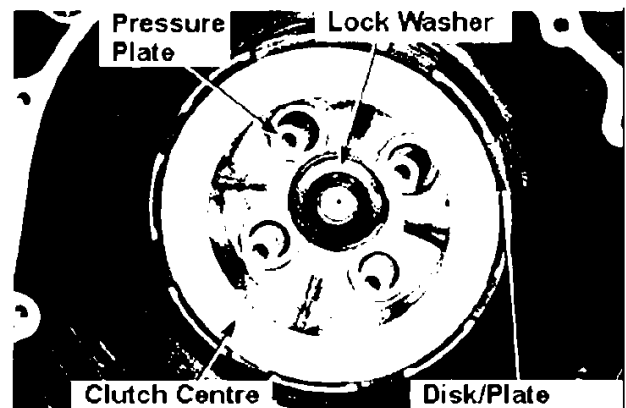

Remove the thrust washer

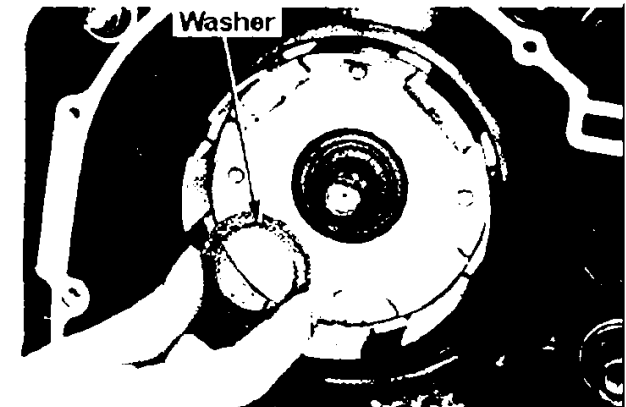

Attach the woodruff key to the crankshaft and attach the flywheel. Rotate the flywheel clockwise until the weight and conrods on the crankshaft do not obstruct when detaching the primary driver gear.

Paint the engaging part between the primary driver gear and a primary drive gear, first cam gear as shown in the photo on the right.

Wipe off oil when painting

Detach the stopper plate.  
Detach the flywheel and the clutch outer.

Do not rotate the crankshaft while detaching the clutch outer.

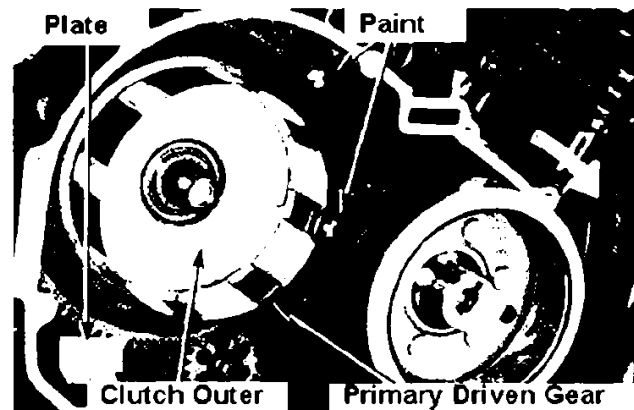

Detach the needle bearing and the clutch outer guide.

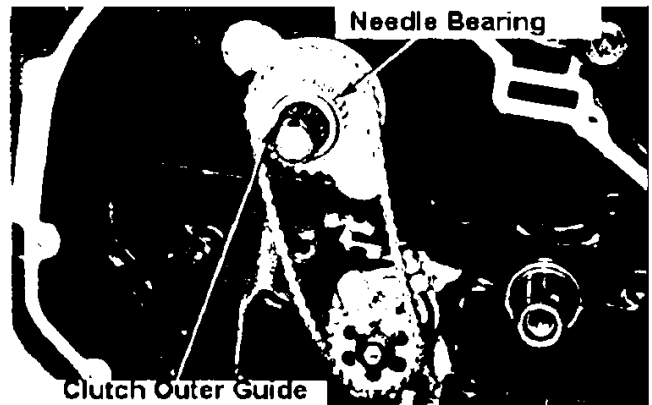

Remove bolts and washers. Detach oil pump drive sprocket, collar, chain and the oil pump driven sprocket.

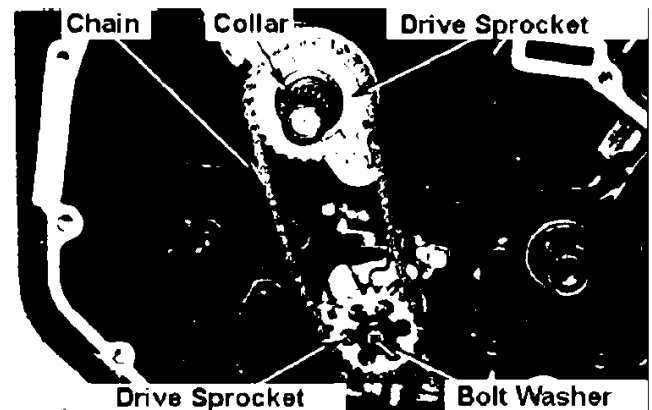

Detach the clutch outer collar from the clutch outer.

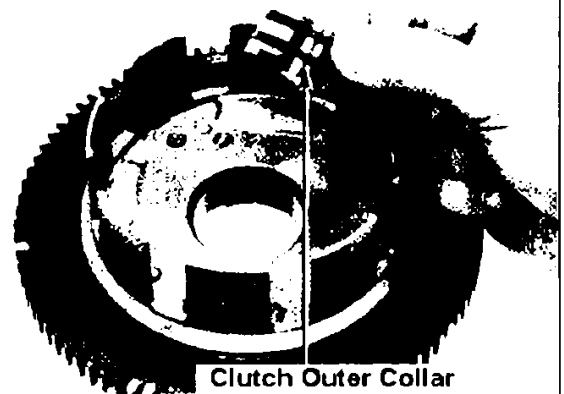

**Lifter plate bearing inspection**

Rotate the inner surface of the bearing by hand. Inspect for loose attachment or any abnormal noise.

Inspect the slit between the outer surface of the bearing and the lifter surface of the bearing and the lifter plate for any loose parts.

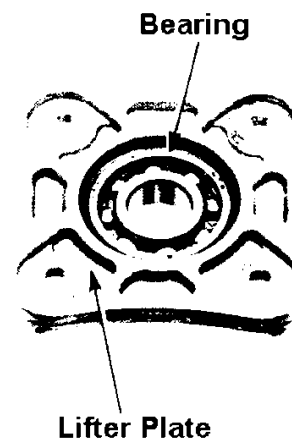

**Clutch Springs Inspection**

Measure the resting length of the spring

$\leq 33.79 \rightarrow$  replace

Replace all springs at the same time

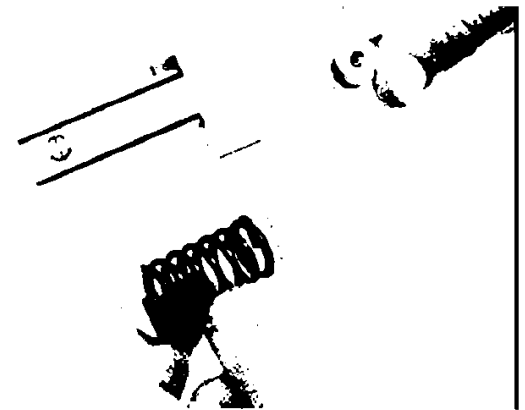
**Clutch Disc Inspection**

Replace the disc if there is any damage or irregular colour.

Measure the thickness of the disc.

$\leq 2.6\text{mm} \rightarrow$  replace

Replace both disc and the plate at the same time.

**Clutch Plate Inspection**

Place the plate on a working table.  
Measure the distortion of the plate with a thickness gauge.

$\geq 0.3\text{mm} \rightarrow$  replace

**Clutch Centre and the Spring Seat Inspection**

Inspect the slits on the clutch centre for stop wear, damage or cracking.  
Inspect the spring seat for deformation, wear and damage.

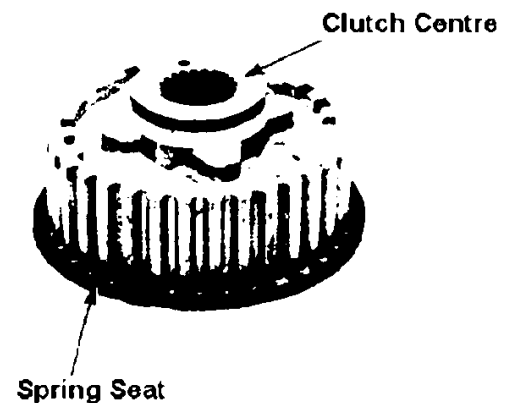



**Shudder Spring Inspection**

Inspect the spring for deformation, distortion, damage or wear.

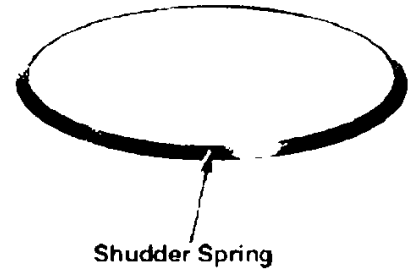

**Clutch Outer Inspection**

Inspect the clutch outer for damage, cracking or irregular wear caused by the disc. Inspect the creeks for wear and damage. Inspect the primary driven gears for wear and damage.

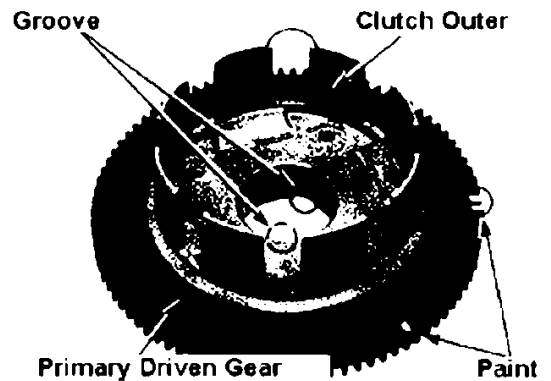

Paint the new clutch outer/primary driven gear on the same place as the old one when it needs to be replaced.

**Clutch outer guide, clutch outer collar and needle bearing inspection**

Measure the inner diameter of the clutch outer guide.

$\geq 22.03\text{mm} \rightarrow \text{replace}$

Inspect the O-Ring on the clutch outer collar for deformation. Inspect the creek for wear and damage. Inspect the roller on the needle bearing for wear and damage.

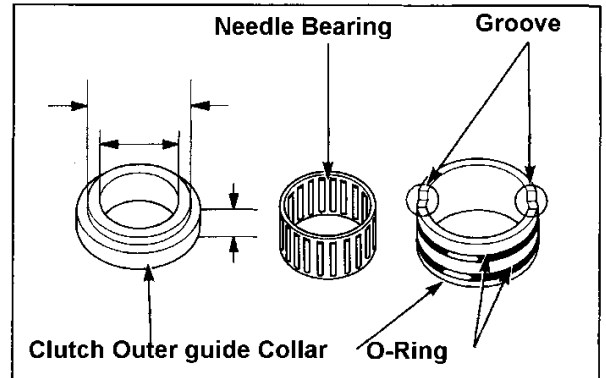

**Oil pump drive sprocket and collar inspection**

Measure the inner diameter of the oil pump drive sprocket.

$\geq 30.09\text{mm} \rightarrow \text{replace}$

Measure the dimension of the collar.

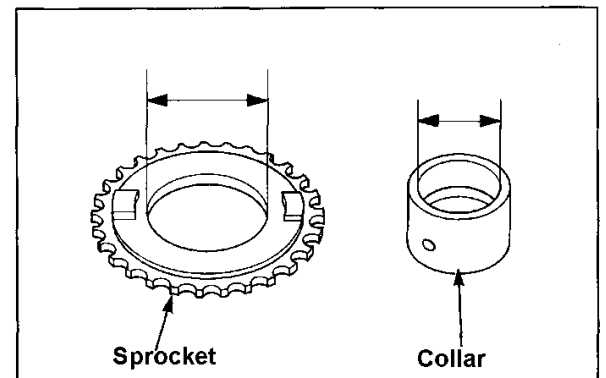

- Inner Diameter:  $\geq 22.03\text{mm}$  )
- Outer Diameter:  $\leq 29.97\text{mm}$  ) replace
- Height:  $\leq 22.20\text{mm}$  )

**Main Shaft Inspection**

Measure the clutch outer guide, drive sprocket collar contact surface.

$\leq 21.97\text{mm}$  → replace

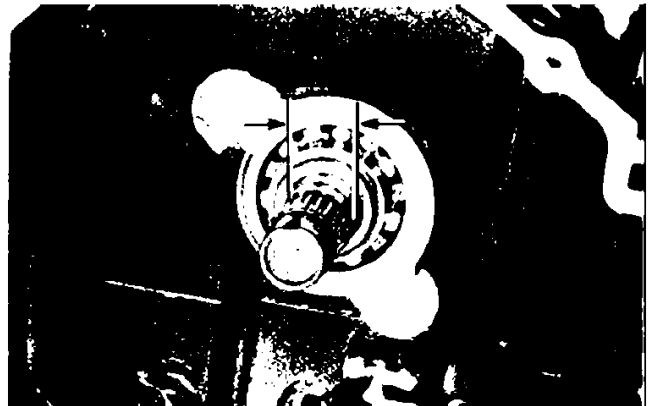

**Attachment**

Attach the oil pump drive sprocket collar to the main shaft.

Attach the oil pump drive gear, chain and oil pump driven sprocket as an ASSY.

Apply screw-locking fluid to the thread of the driven sprocket attachment bolt and tighten with the washer to torque.

**Torque:** 1.3 ~ 1.7kg m

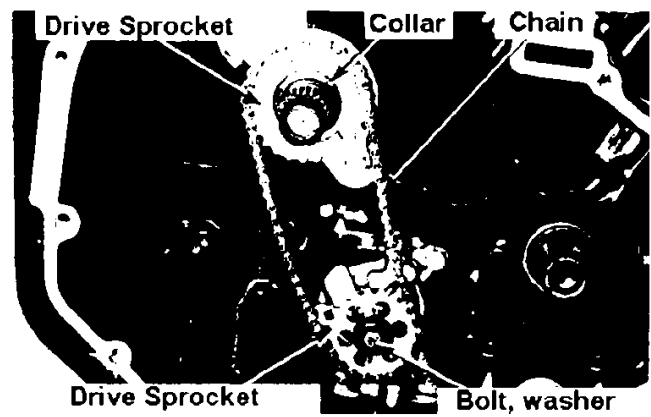

Apply oil to the bearing on the clutch outer. Apply oil to the O-Ring and attach the clutch outer collar to the clutch outer.

- As shown in the photo, the collar should be attached from the clutch outer side.
- Align the dent on the collar and the dent on the gear.

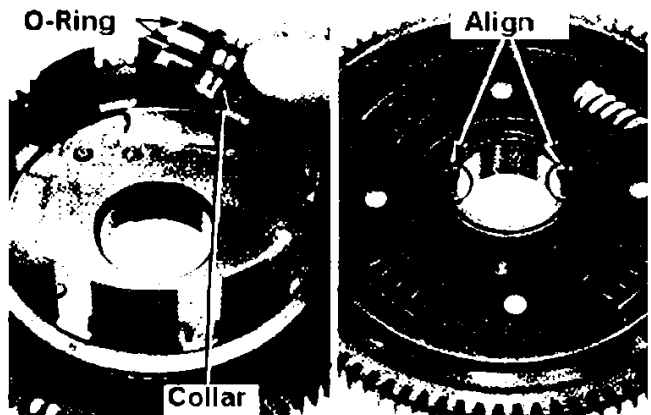

Align the painted marks and attach the gear to the shaft.

Align the projection on the oil pump drive sprocket and the dent on the primary driven gear.

Match the primary driven gear to the first cam gear.

Attach the needle bearing.

Attach the clutch outer guide.

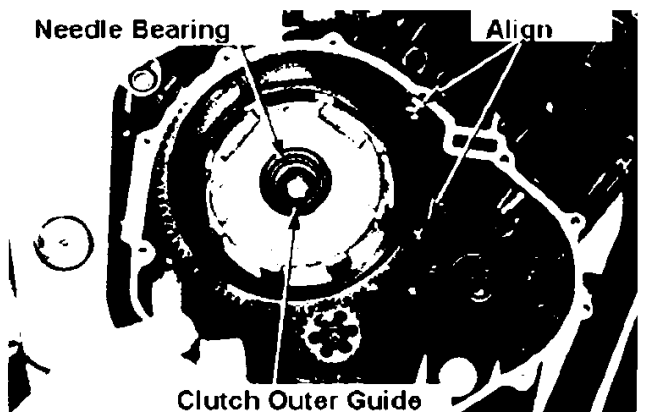

Firmly attach the stopper plate.

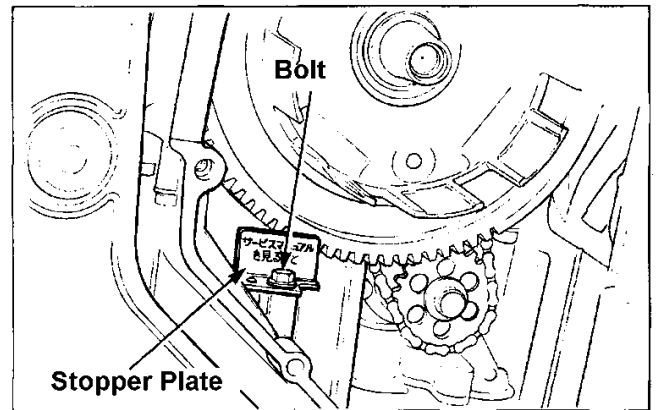

Attach the thrust washer to the main shaft.

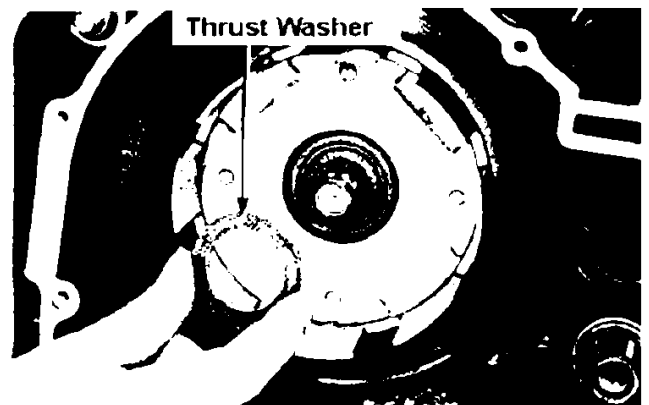

Apply engine oil to the clutch disc and the clutch plate. Attach the shudder spring seat, shudder spring, disk, plate and the washer plate to the clutch centre.

Refer this figure to install a shudder spring, shudder spring seat and the clutch disc A.

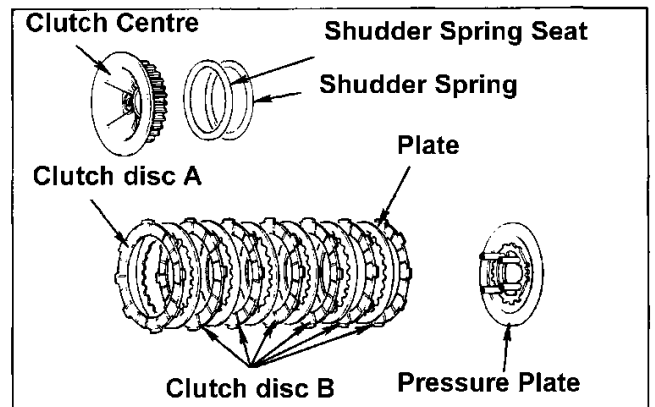

Attach the clutch centre, spring seat, shudder spring, disc, plate and the pressure plate as an ASSY to the clutch outer.

Attach the lock washer.

Attach the new lock nut.  
 Attach the clutch centre holder.  
 Fix the clutch and tighten the lock nut.

**Torque: 6.0 ~ 7.0kg m**

**Excl. Tool** Clutch centre holder:  
 07GMB – KT70100

**Common Tool** Locknut wrench  
 (26 x 30mm)  
 07716-0020203

Extension Bar 07716-0020500

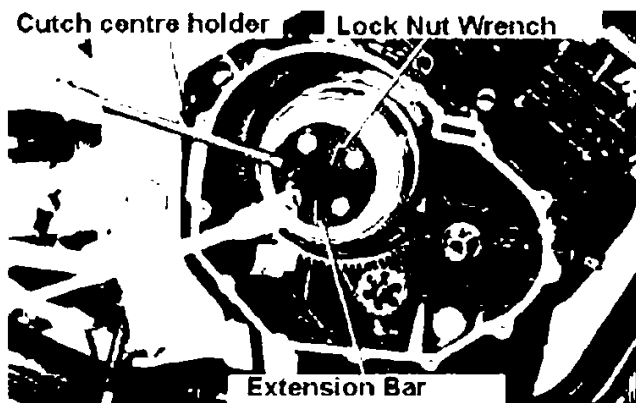

Firmly tighten the remaining thread of the locknut.

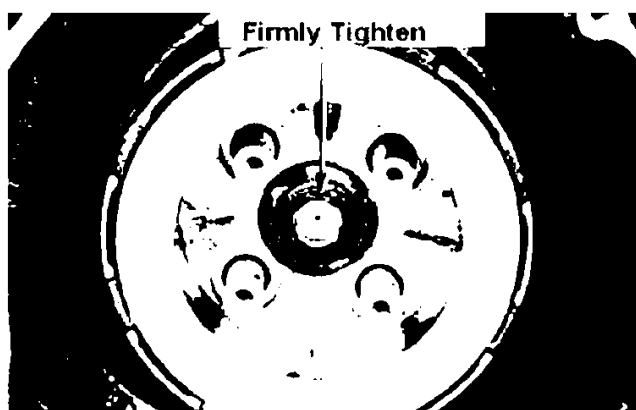

Install the clutch spring.  
 Attach the clutch lifter plate, tighten with bolts.

Tighten the opposite corner bolts each time.

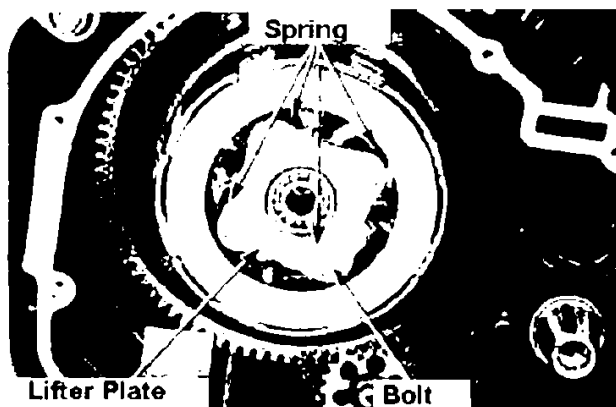

**AC Generator Attachment**

Attach the woodruff key to the crankshaft.

It is already attached if the clutch was disassembled.

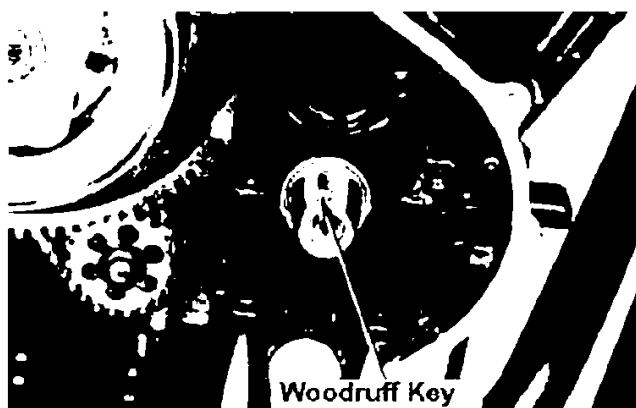

Attach the flywheel to the crankshaft.  
Fix the flywheel with the flywheel holder and tighten the bolt.

**Torque: 8.0 ~ 9.0kg m**

**Common Tool** Flywheel holder:  
07725-004000

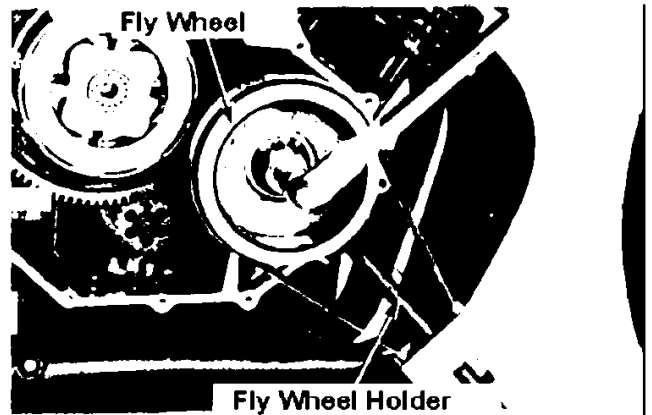

Attach the stator to the right crankcase cover.  
Apply screw locking fluid to the thread on the bolts and attach the AC Generator wire clamp.  
Install the grommet correctly.

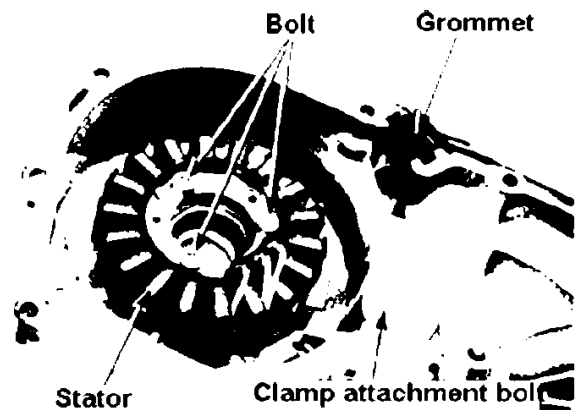

### Right crankcase cover attachment

#### Assembly

Install the clutch lifter arm and attach the spring stopper.

Check the free rotation of the arm after installing the stopper.

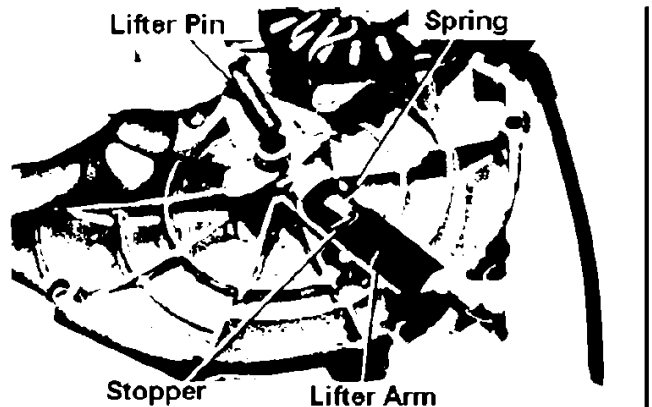

Install the spring, then the lifter pin.

- One side of the stopper attachment hole on the lifter arm has a round edge. The spring is supposed to be attached.
- Align the lifter pin to the dent on the lifter arm. Push the pin and firmly set.

Attach knock pins and the gasket.

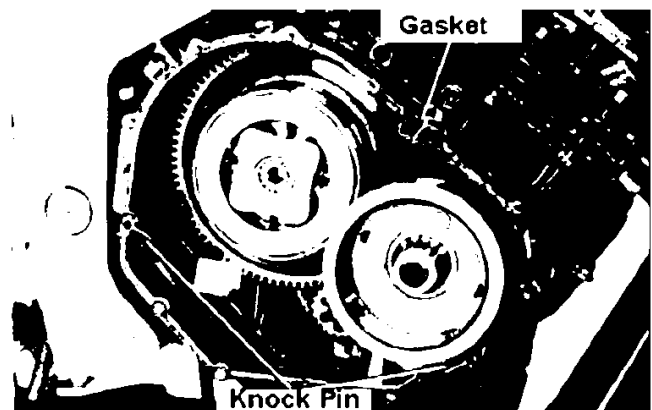

Apply oil to the right crankcase cover attachment bolts and attach the cover.

Torque: 0.8 ~ 1.2kg m

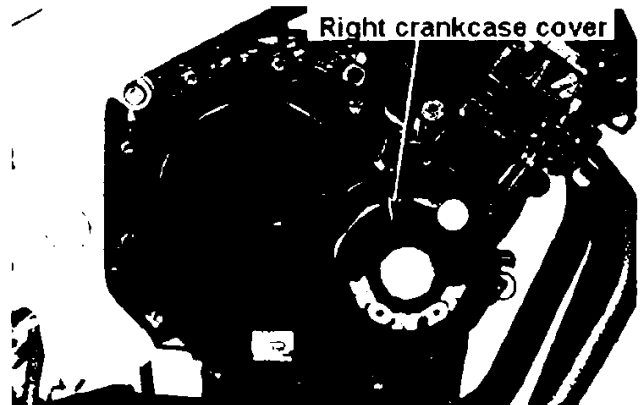

Connect the clutch cable to the lifter arm.

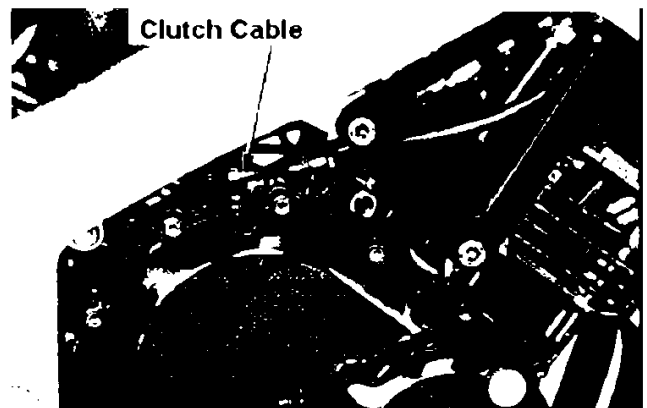

Place the AC generator wires correctly (1-22).

Connect the 3P coupler of regulator/rectifier and attach with nuts.

Attach the side cover, and the seat (21-42)

Fill with recommended engine oil (2-15).

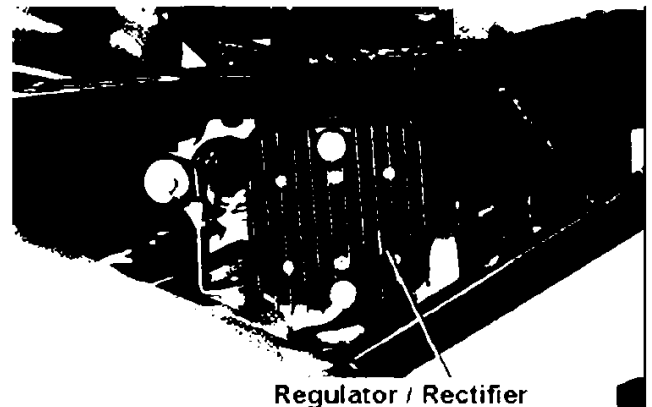

• Disassembly

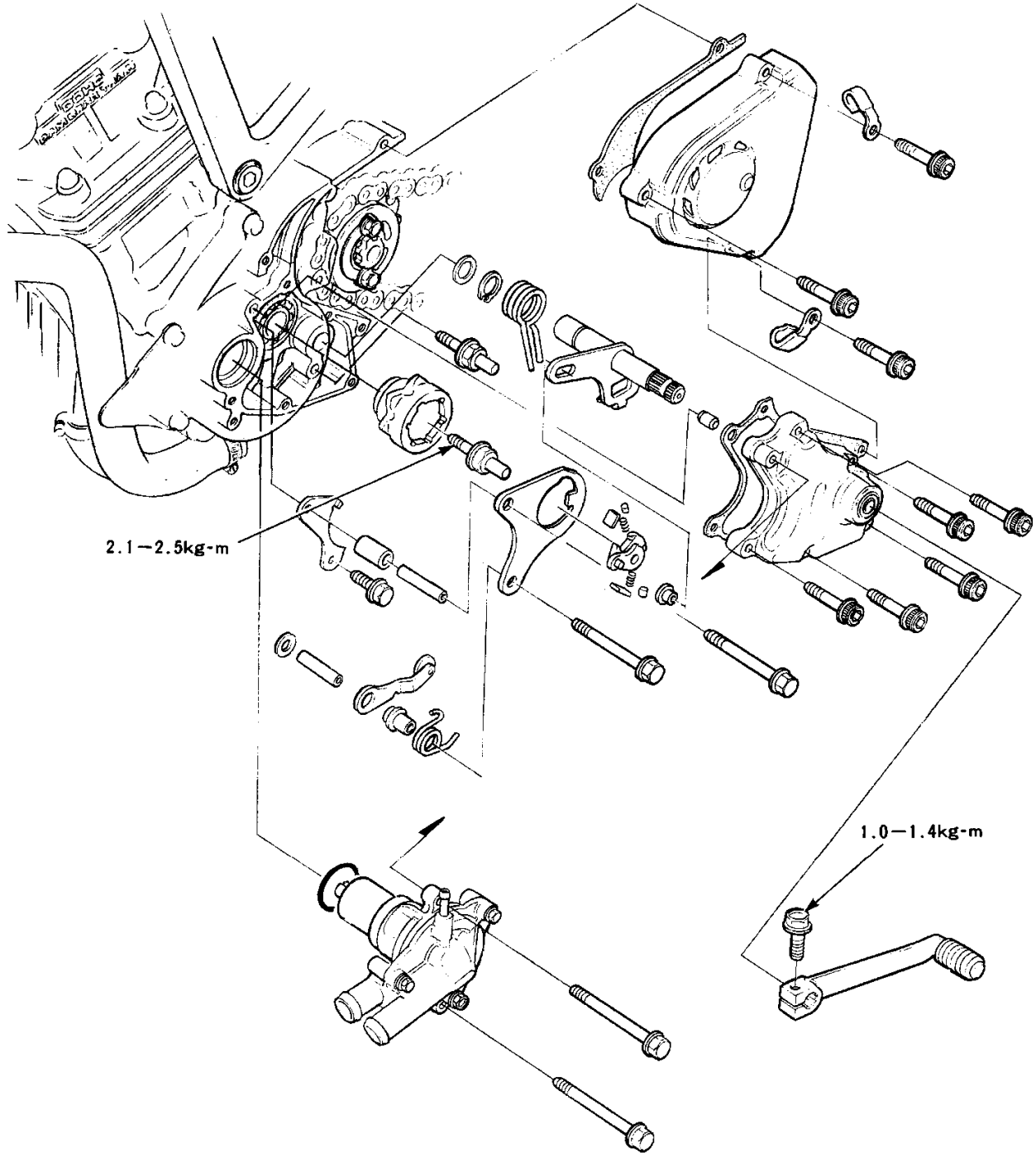

Disassembly	11-0	Gear shift linkage detachment	11-2
Service information	11-1	Gear shift linkage attachment	11-4
Troubleshooting	11-1		

### **Service Information**

#### **General Caution**

- The gear shift linkage can be serviced without dismounting from the vehicle.
- When the transmission, shift drum and the shift fork need to be serviced, disassemble the crankcase.

#### **Torque**

- Change Pedal 1.0 – 1.4kg-m
- Drum centre bolt 2.1 – 2.5kg-m (apply screw locker)

### **Troubleshooting**

#### **Difficult to shift the gear**

- Inadequate clutch adjustment
- Shift fork deformed
- Cam slit on the shift drum damaged
- A catch on the gear shift spindle bent

#### **The gear disconnects**

- Gear dog worn
- Shift shaft bent
- Stopper arm damaged
- Shift fork bent / damaged



### Gear Shift Linkage Detachment

Remove the water pump (5-9)  
Remove the change pedal  
Detach the drive sprocket cover

**Note:**

Set the gear to neutral before removing the change pedal.

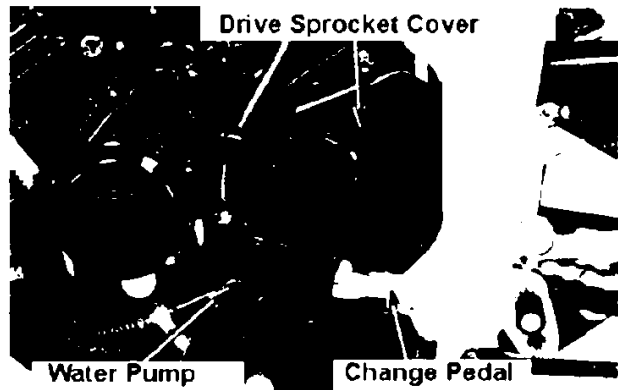

Remove the five change cover attachment bolts.  
Push the shift spindle in and remove the change cover.

Remove the gasket and knock pins.

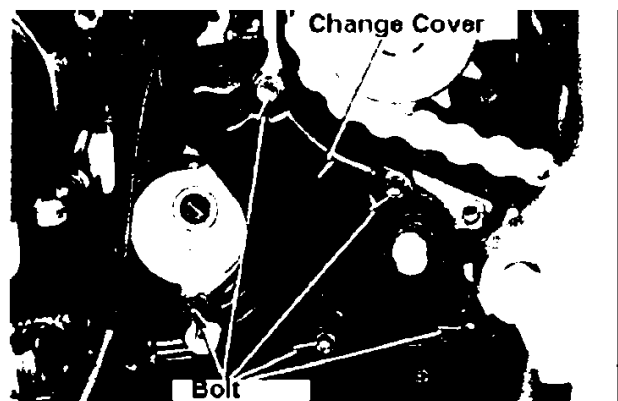

Remove the gear shift spindle and washer.  
Remove the shifter collar.

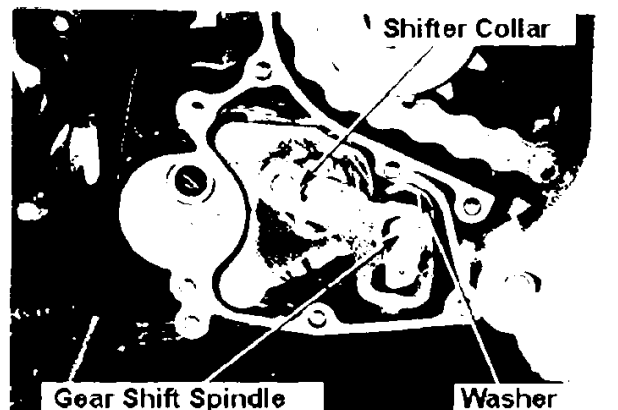

Remove the two bolts and detach the guide plate with the drive shifter.

**Caution:**

A ratchet pole may pop out.

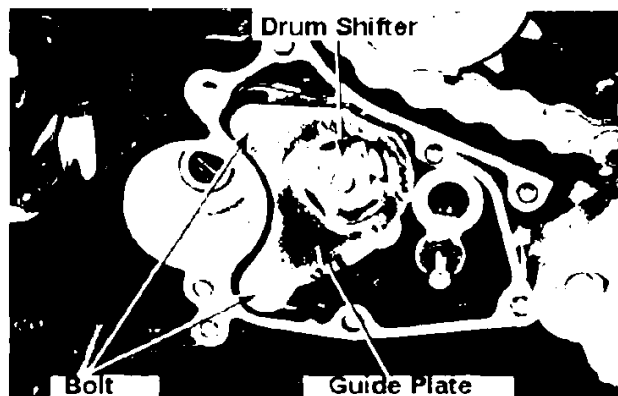

Detach the stopper arm, spring, shaft and the washer.

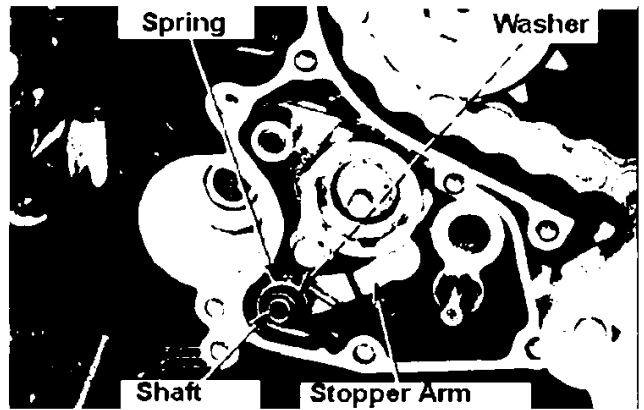

Remove the drum centre bolt and detach the drum centre.

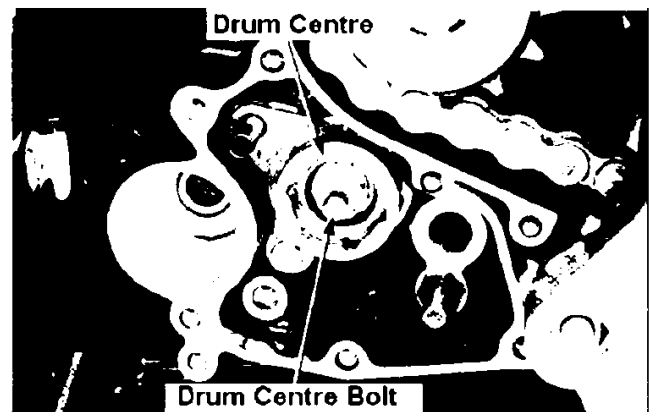

**Gear Shift Spindle**

### Gear shift spindle inspection

Inspect the gear shift spindle for wear / damage.  
Inspect the spring for permanent deformation / damage.

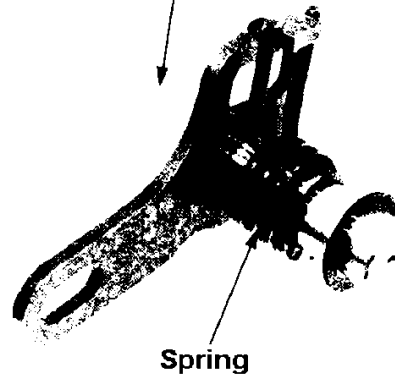

### Guide plate assembly

Apply clean engine oil to the drum shifter, pole flanges, ratchet poles and springs.

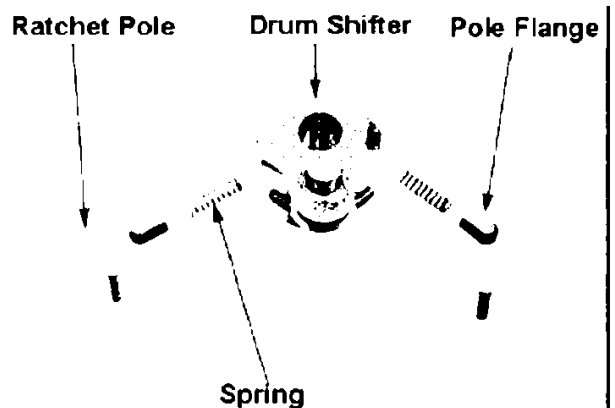

Attach the drum shifter, pole flanges, springs and ratchet poles to the guide plate.

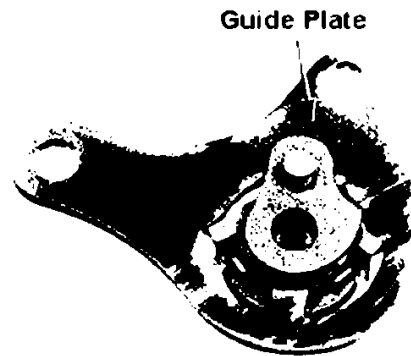

### Gear shift linkage attachment

Align the key slit on the drum centre to the drum pin and attach.

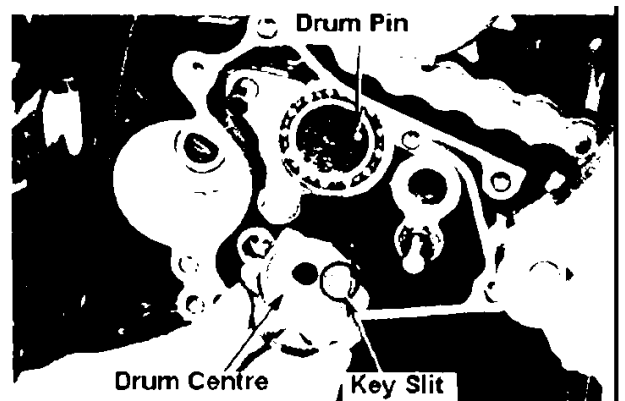

Apply screw locker to the thread and tighten the drum centre bolt.

**Torque: 2-1 ~ 2.5kg-m**

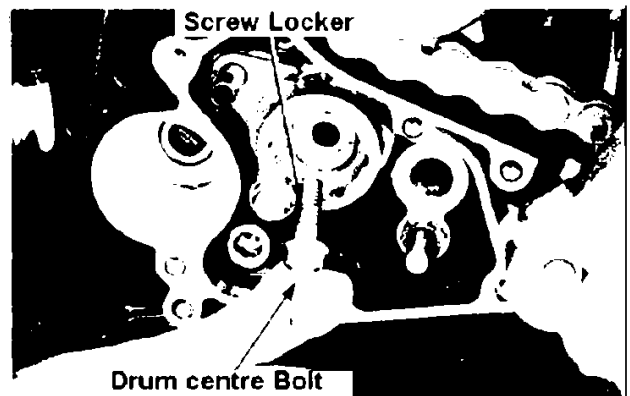

Attach the stopper arm shaft and the washer.

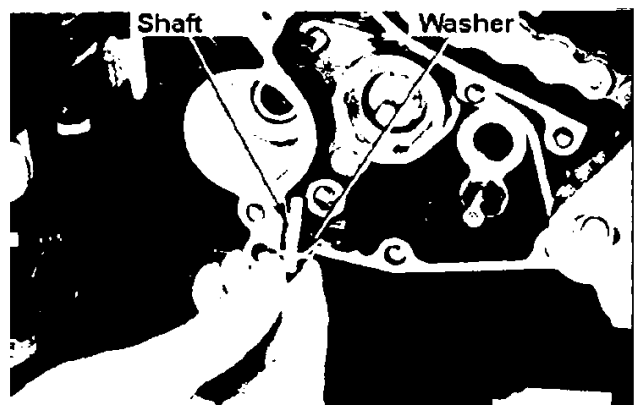

Attach the stopper arm and the spring to the stopper arm shaft.

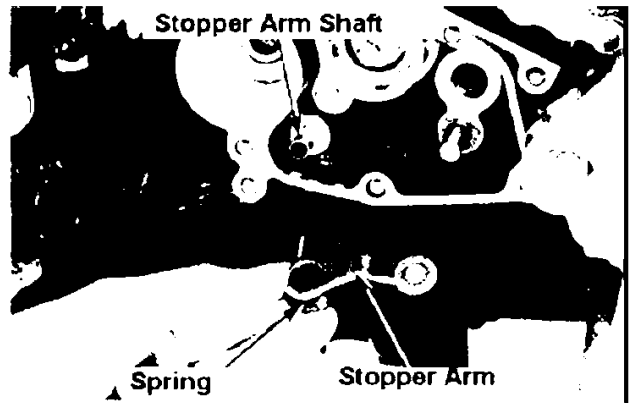

Attach the drum shifter and the guide plate.

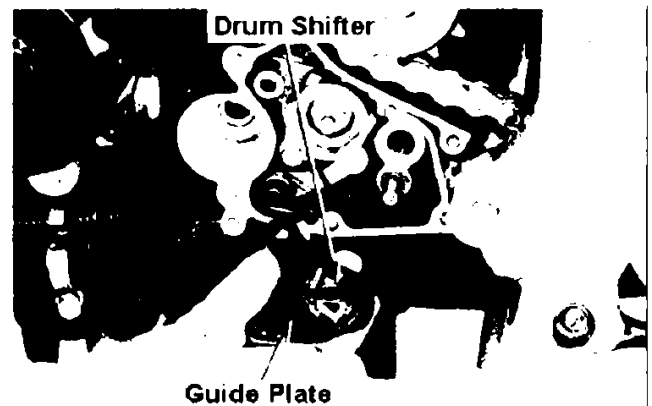

Firmly tighten the two guide plate attachment bolts.

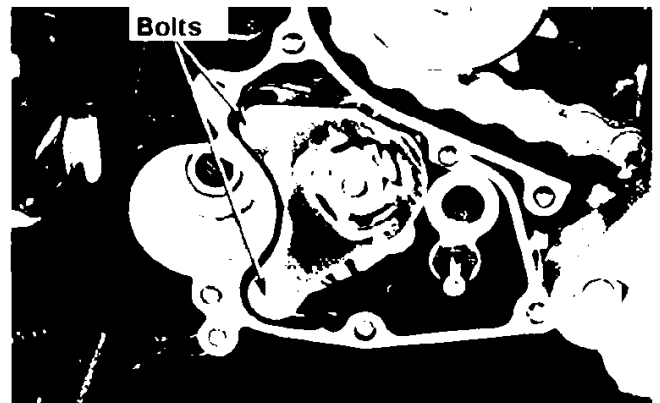

Cover the projection of the drum shifter with the shifter collar.

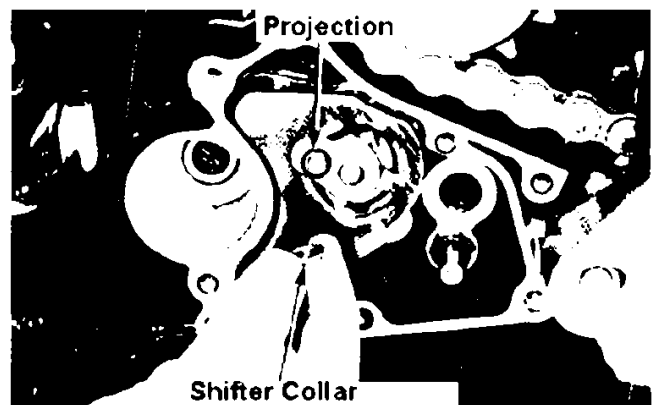

Attach the gear shift spindle and the washer.

After attaching them, rotate the spindle and check the linkage movement.

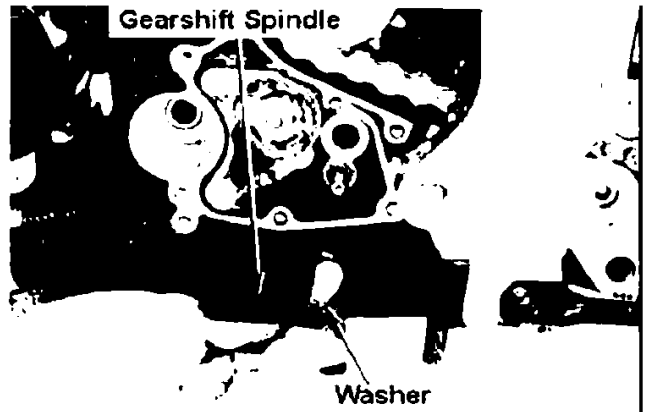

Attach the change cover with a new gasket and knock pins.

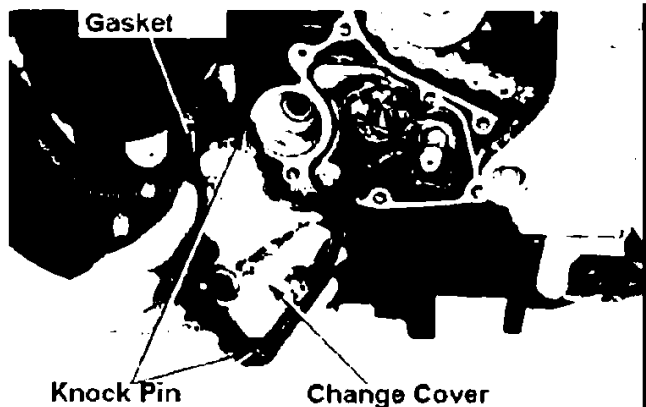

Tighten the five change cover attachment bolts.

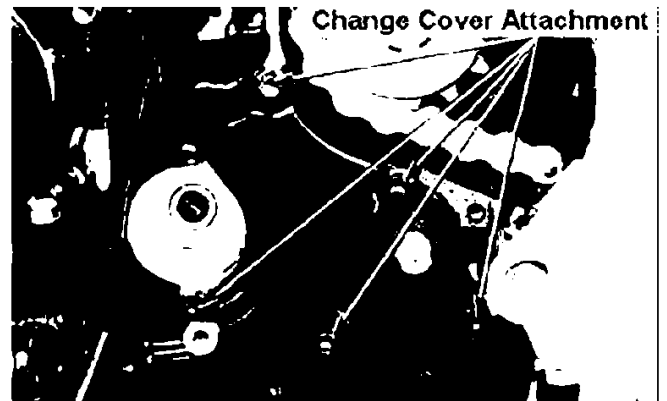

Attach the gasket to the drive sprocket cover.

When the cover plate is removed, apply screw locker to the plate bolt and attach it.

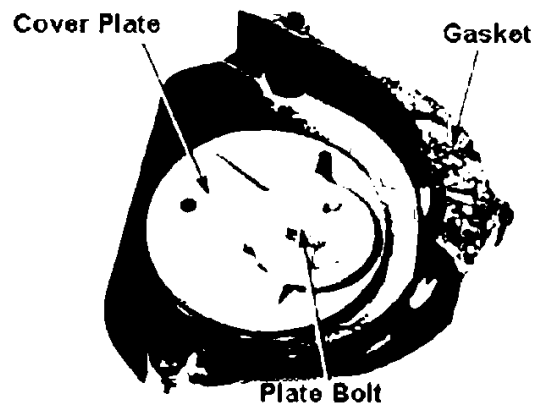

Attach the drive sprocket cover and tighten the three attachment bolts.

Attach the change pedal

**Torque: 1.0 ~ 1.4kg-m**

Attach the water pump (5-9)

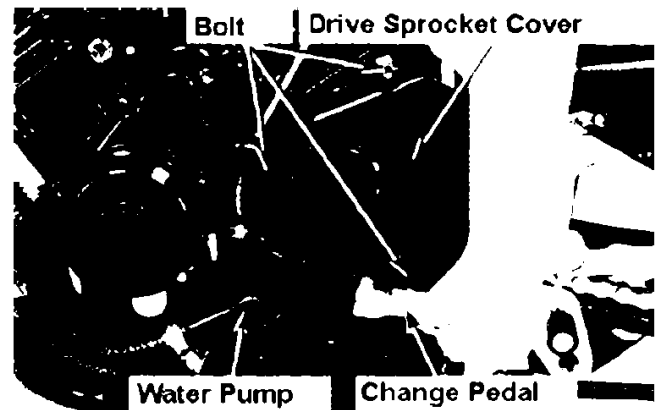

- **Disassembly**

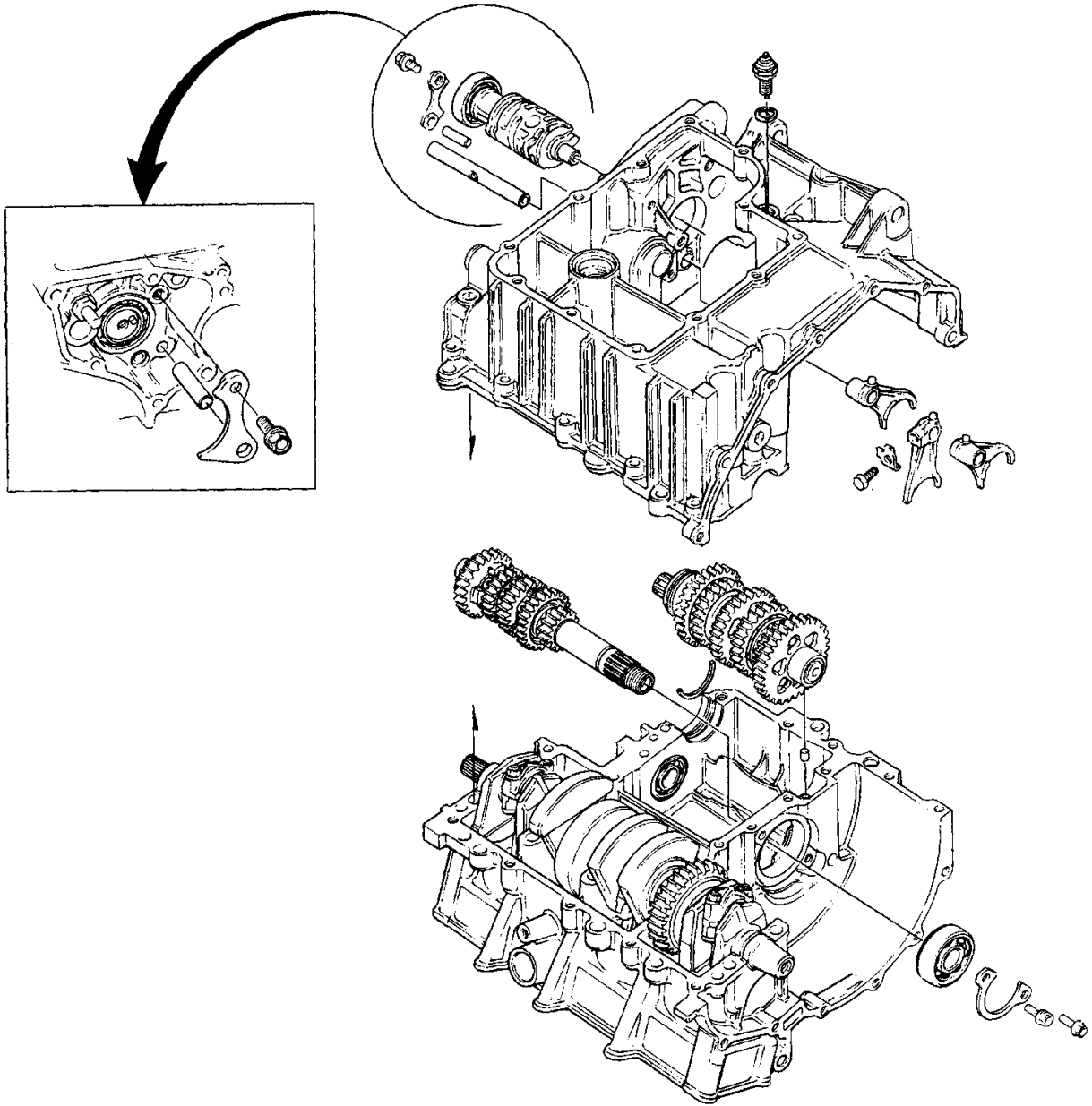

## Transmission

Disassembly	12-0	Transmission Disassembly	12-3
Service Information	12-1	Transmission Inspection	12-5
Troubleshooting	12-2	Transmission Assembly	12-7

## Service Information

### General Caution

- Inspection of the transmission inside the crankcase should be conducted after separating the case.
- Separation of the crankcase → Sec. 8

## Service Standard

Unit: mm

Item		Standard	Limitation	
Transmission	Backlash	0.044-0.140	0.3	
	Gear inner diameter	M5	25.000-25.021	25.05
		M6	25.000-25.021	25.05
		C1	23.000-23.021	23.05
		C2	28.000-28.021	28.05
		C3	28.000-28.021	28.05
		C4	28.000-28.021	28.05
	Gear Bush	M5 inner dia	21.985-22.006	22.07
		M5 outer dia	24.959-24.980	24.92
		M6 outer dia	24.959-24.980	24.92
		C1 outer dia	22.959-22.980	22.92
		C1 inner dia	20.007-20.028	20.10
		C2 outer dia	27.959-27.980	27.92
		C3 outer dia	27.959-27.980	27.92
	Main shaft outer diameter	M5 at M5	21.959-21.980	21.92
		At clutch outer guide	21.980-21.990	22.20
	Counter shaft outer dia	C1 at C1	19.987-20.000	19.77
	Gear-bush or Bush-shaft clearance	M5 – bush	-	0.10
		M5 bush – shaft	-	0.15
		M6 – bush	-	0.10
		C1 – bush	-	0.10
		C1 – bush-shaft	-	0.15
C2 – bush		-	0.10	
C3 – bush		-	0.10	
Shift fork	Thickness of a catch	-	5.60	
	Inner dia	-	12.04	
Shift fork shaft	Outer dia	-	11.90	



**Troubleshooting****Difficult to select a gear**

- Inadequate clutch setting (too much free movement)
- Shift fork bent
- Shift fork shaft bent
- Gear shift spindle damaged
- Shift drum guide slit damaged
- Guide pin damaged

**The gear disengages**

- Gear dog worn out
- Shift fork shaft bent
- Shift drum stopper damaged
- Shift fork bent
- Shift drum guide slit worn out

## Transmission disassembly

Separate the crankcase (Sec. 8)  
Measure the backlash of each gear

**Backlash > 0.3mm → replace**

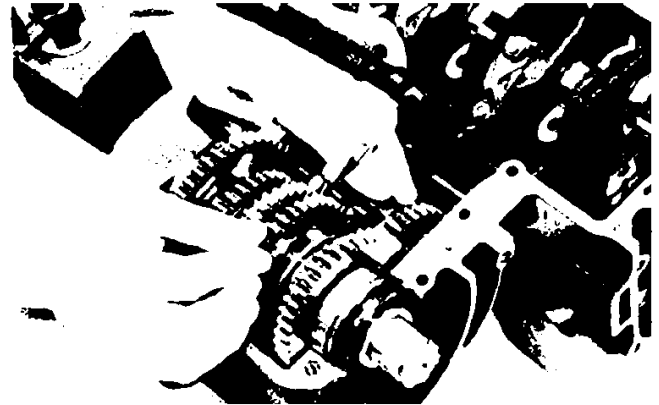

Remove the countershaft.

Detach the knock pin and the bearing set ring.

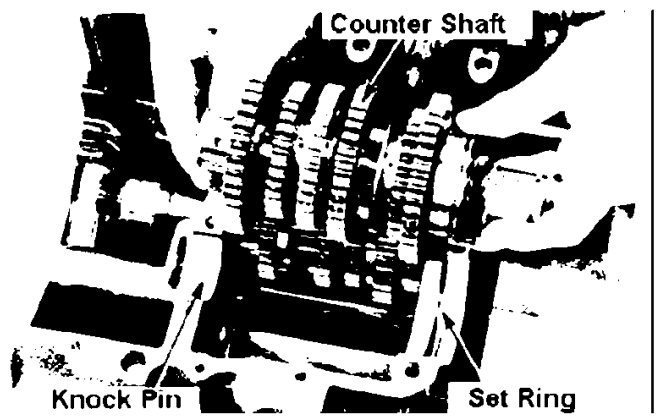

Remove two bolts and detach the stopper plate.

Pull out the bearing.

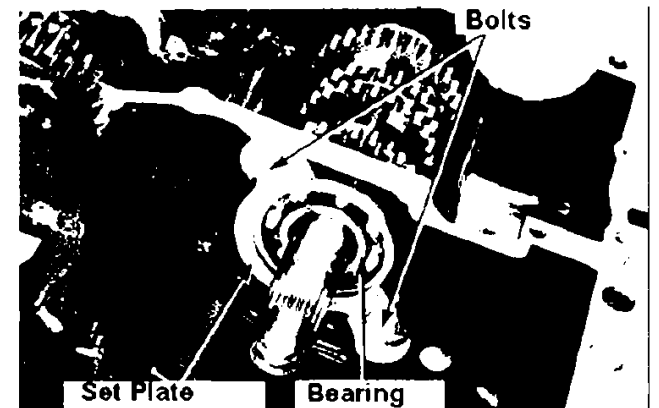

Remove the main shaft.

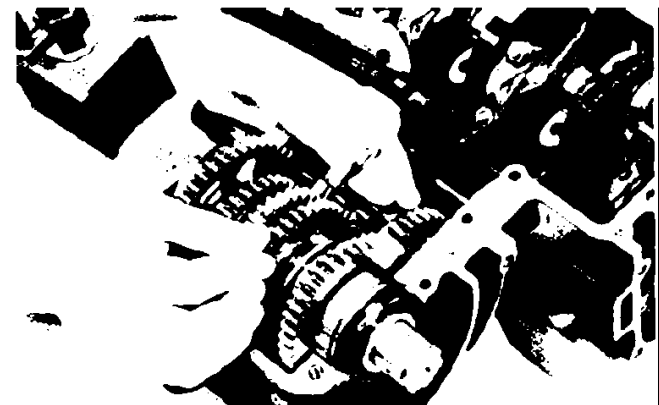

Fold the catch on the lock washer and remove the bolt and washer.

Pull out the shift fork shaft and detach shift forks.

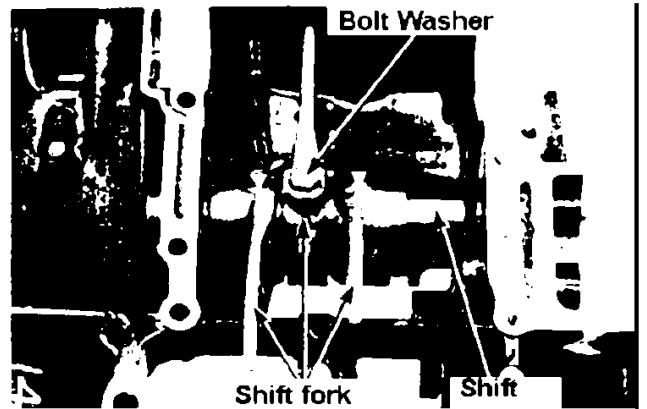

Remove the bolt to detach the set plate and knock pin.

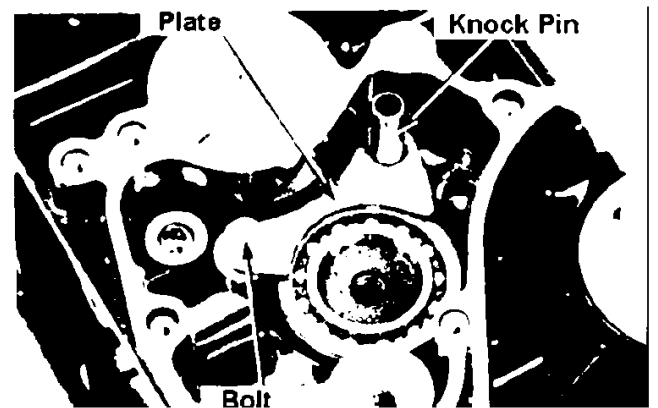

Detach the shift drum.

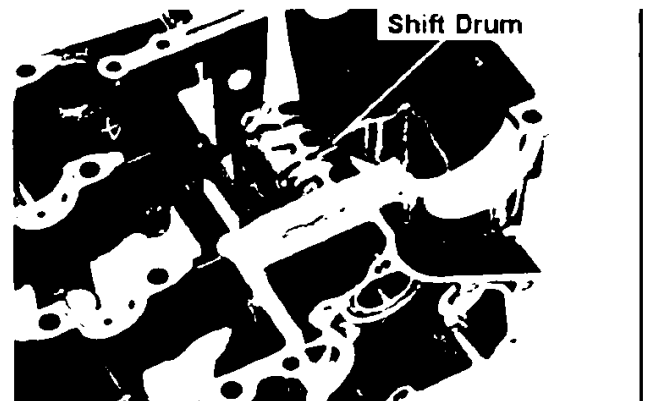

Inspect bearings for the shift fork shaft and the shift drum.

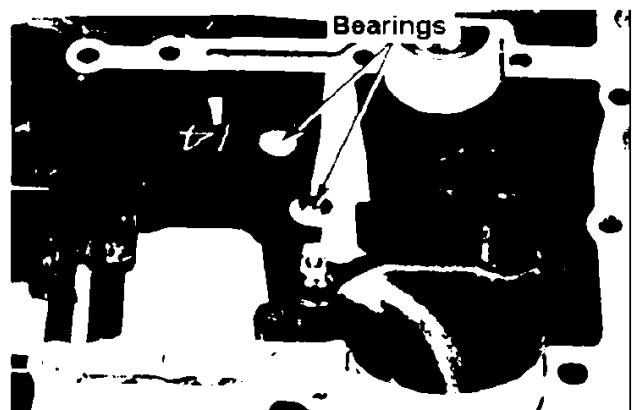

## Transmission Inspection

Inspect the shift drum bearing for smooth rotation or any loose fit.  
Inspect guide slits on the drum for damage or wear.

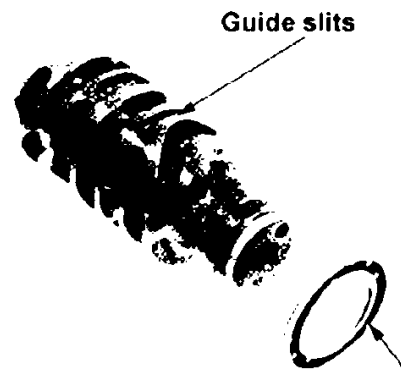

Inspect the shift fork for damage.  
Measure the inner diameter and the thickness of the catch of the fork.

Inner diameter:  $\geq 12.04\text{mm}$  )  
Thickness of the catch:  $< 5.60\text{mm}$ ) Replace

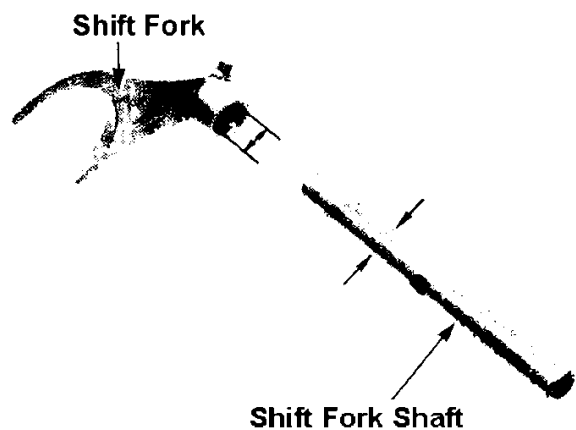

Inspect the shift fork for bend and damage.  
Measure the outer diameter of the shaft.

Outer diameter  $< 11.90\text{mm}$  → replace

Inspect the main shaft bearing for smooth rotation or loose fit.

Disassemble the main shaft and the counter shaft.

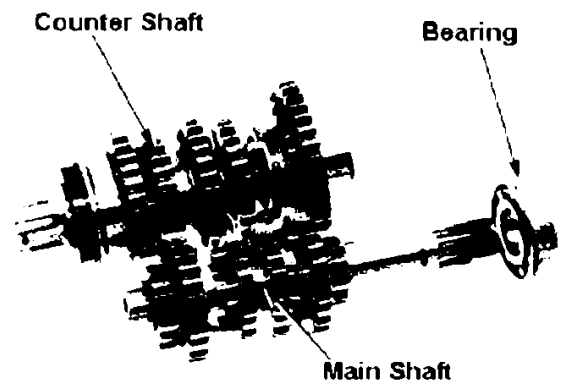

Inspect the needle bearing and the outer race on the counter shaft bearing for damage.

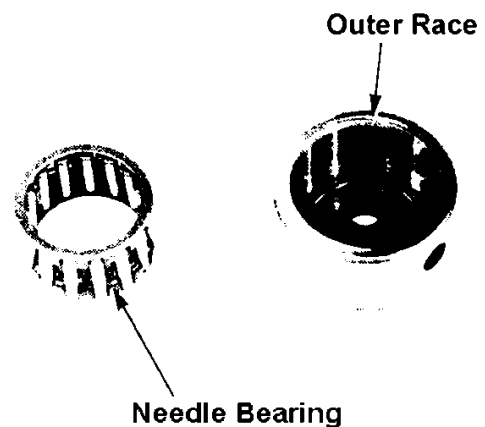

Inspect the main shaft and the counter shaft for damage.

Inspect the countershaft bearing for smooth rotation and loose fit.

Measure outer diameter of each shaft.

M5 part:	$\leq 21.92\text{mm}$	)	
Clutch outer guide:	$\leq 21.95\text{mm}$	)	Replace
C1 part:	$\leq 19.97\text{mm}$	)	

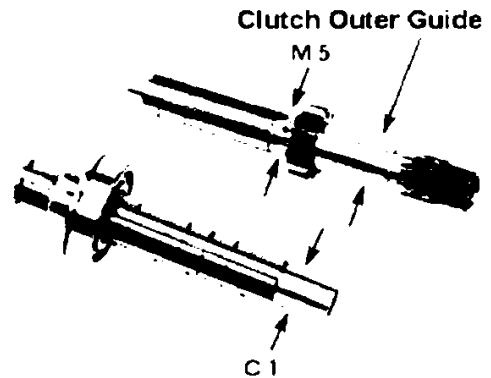

Inspect each gear for damage.

Measure the inner diameters.

M5:	$\geq 25.05$	)	
M6:	$\geq 25.05$	)	
C1:	$\geq 23.05$	)	Replace
C2:	$\geq 28.05$	)	
C3:	$\geq 28.05$	)	
C4:	$\geq 28.05$	)	

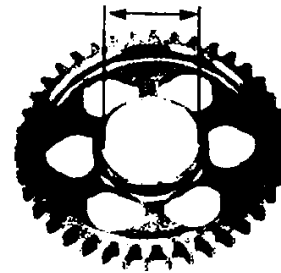

Inspect each bush for damage.

Measure inner / outer diameter for each bush.

M5 inner:	$\geq 22.07\text{mm}$	)	
M5 outer:	$\leq 24.92\text{mm}$	)	
M6 outer:	$\leq 24.92\text{mm}$	)	
C1 inner:	$\geq 20.10\text{mm}$	)	Replace
C1 outer:	$\leq 22.92\text{mm}$	)	
C2 outer:	$\leq 27.92\text{mm}$	)	
C3 outer:	$\leq 27.92\text{mm}$	)	
C4 outer:	$\leq 27.92\text{mm}$	)	

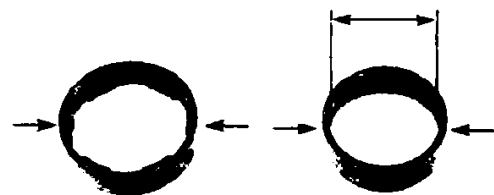

Calculate the clearance between the bush and the gear or the shaft.

Bush – gear	$\geq 0.10\text{mm}$	)	
Bush – shaft	$\geq 0.15\text{mm}$	)	Replace

## Transmission Assembly

Apply engine oil to all contact parts.

Apply grease on shift fork slits of M3/4, C5 and C6 gears.

Apply grease and engine oil to the bush on C1.

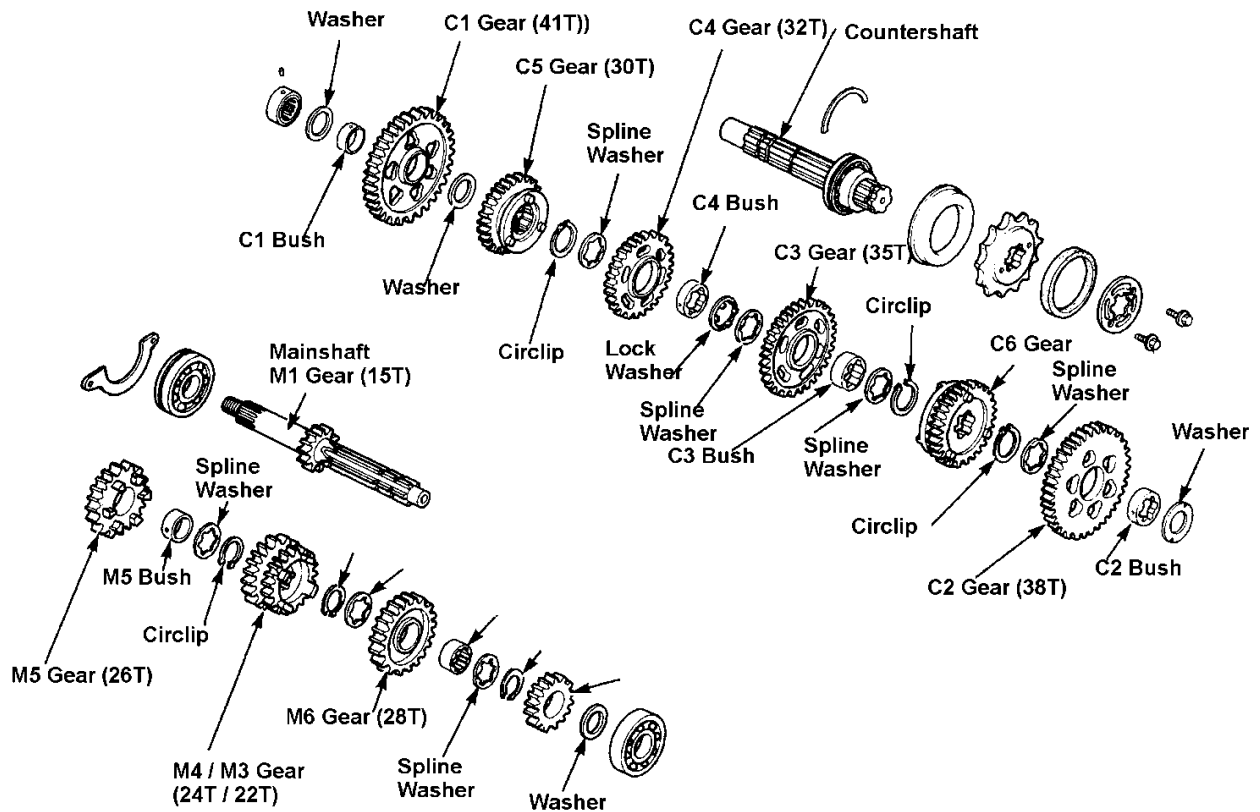

### Important

Align an oil hole on the bush with an oil hole on the shaft.

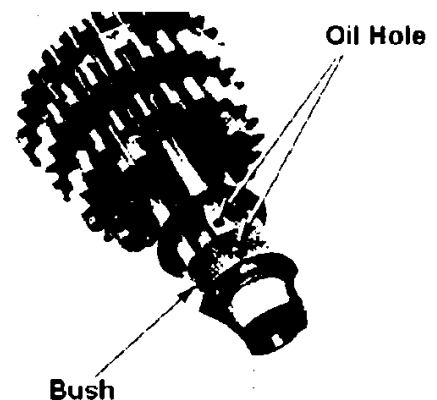

Attach the mainshaft.

Face the marked surface of the bearing outward.

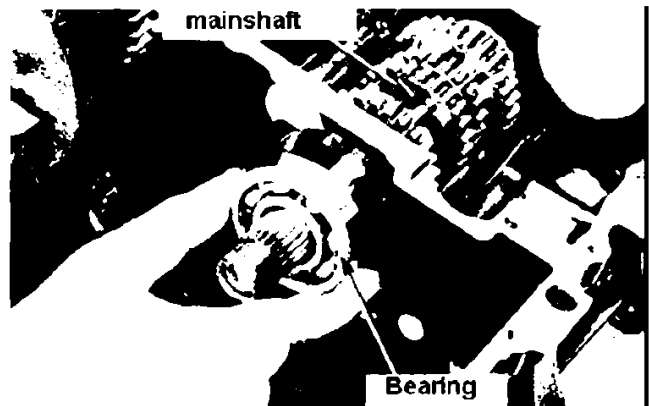

Apply screw holder on bolts and tighten the set plate.

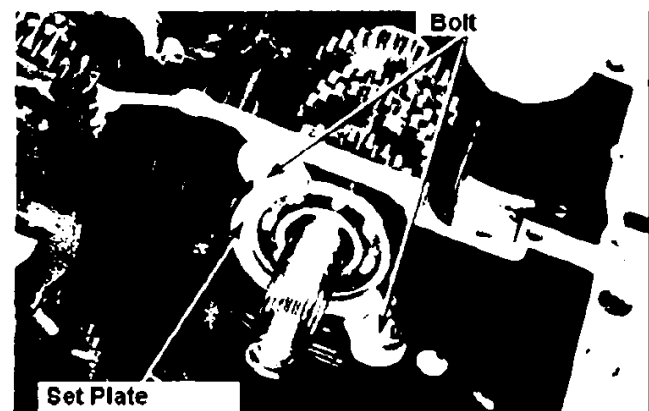

Attach the bearing set ring and the knock pin to the cylinder block.

Align the slit of the bearing with the ring, hole on the collar with knock pin, attach the countershaft.

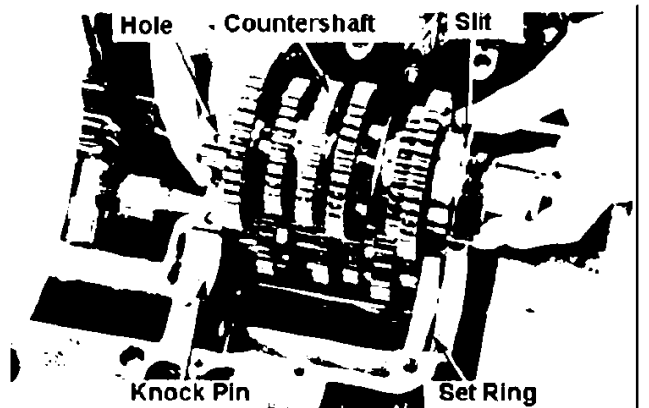

Attach the shift drum and bearing.

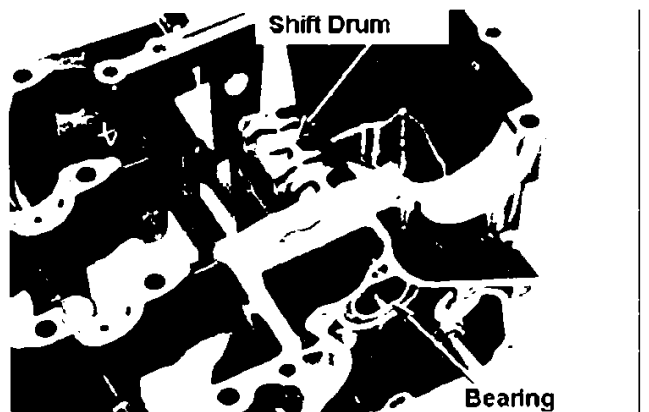

Install the knock pin.

Attach the set plate.

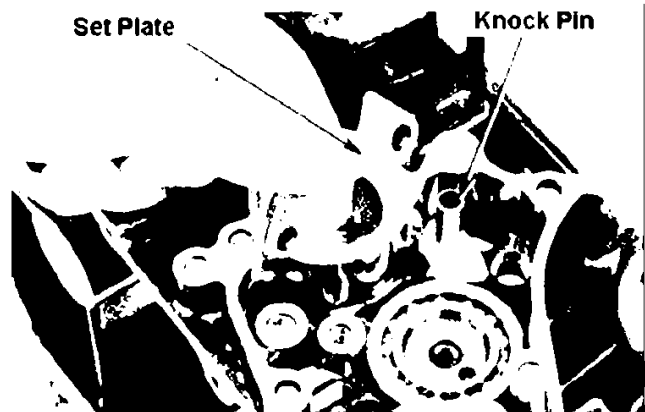

Tighten the bolt.

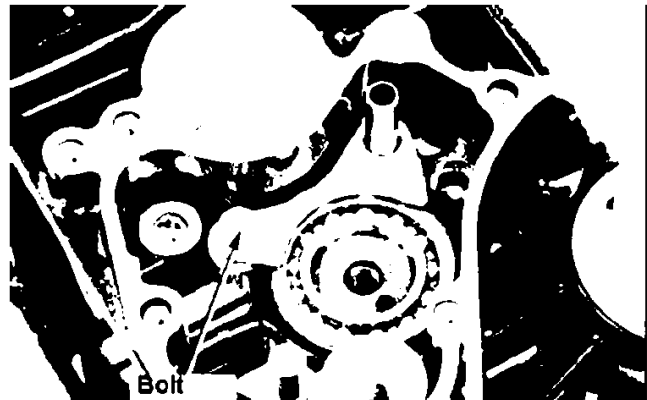

Install the shift fork and the shift fork shaft.

Install the fork so as to face "R", "C", "L" markings towards drive sprocket.

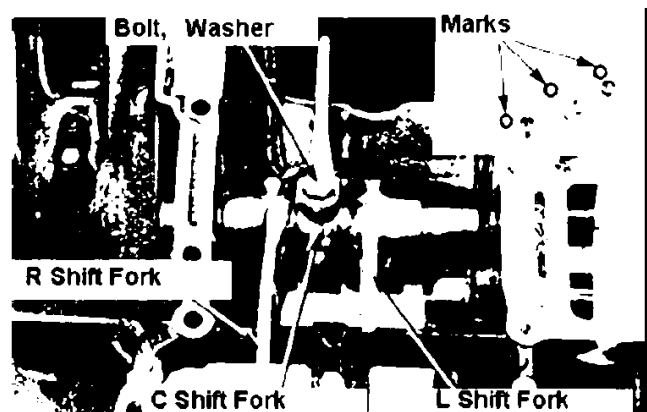

Align the hole on the shift fork shaft and the hole on the C. shift fork, install bolt with the new washer and tighten it.

Bend the catch of the lock washer and lock the bolt.

Assemble the crankcase (Sec. 8).



# CBR250R,RR 13. Front Wheel Suspension Steering

- Disassembly

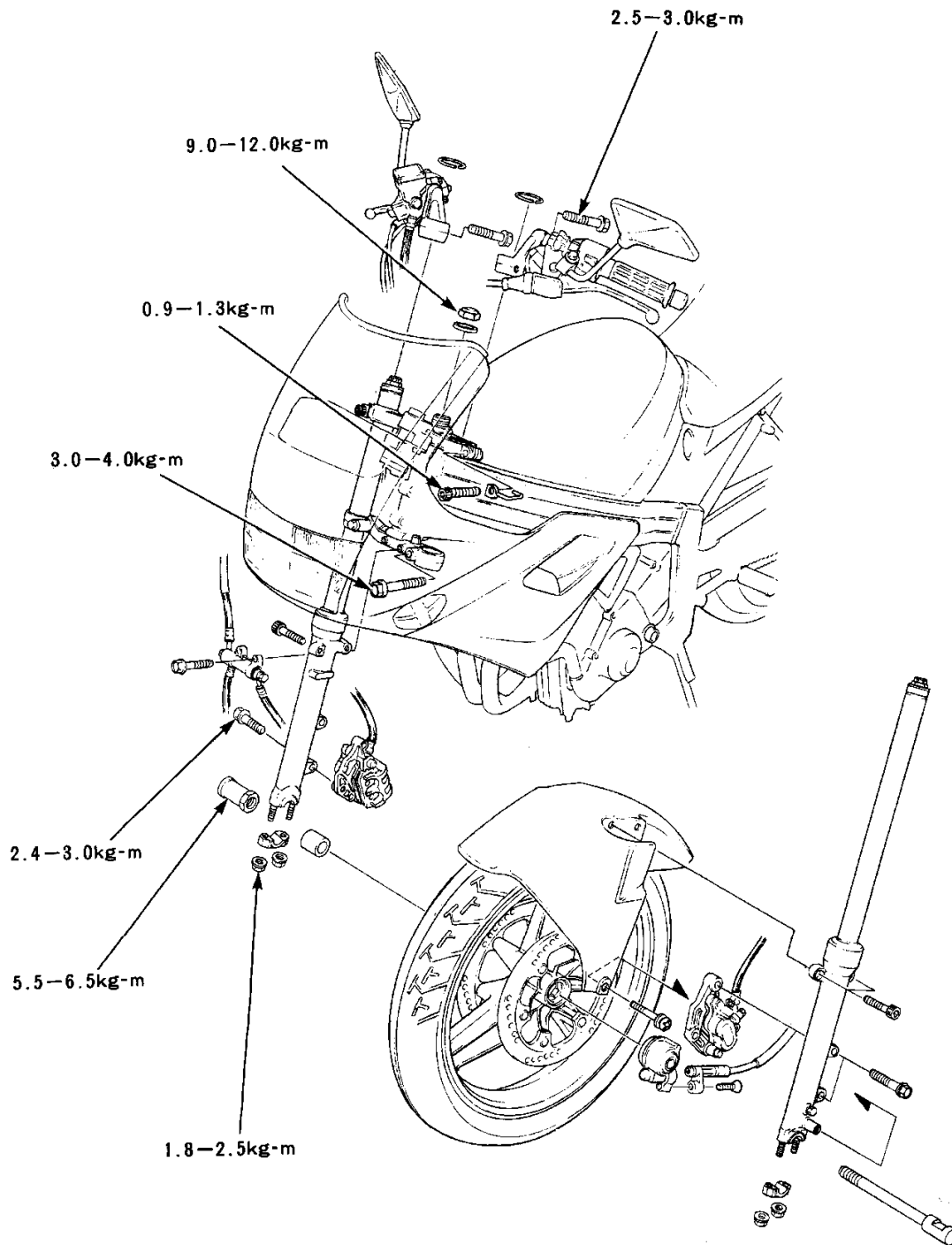

# CBR250R,RR 13. Front Wheel Suspension Steering

---

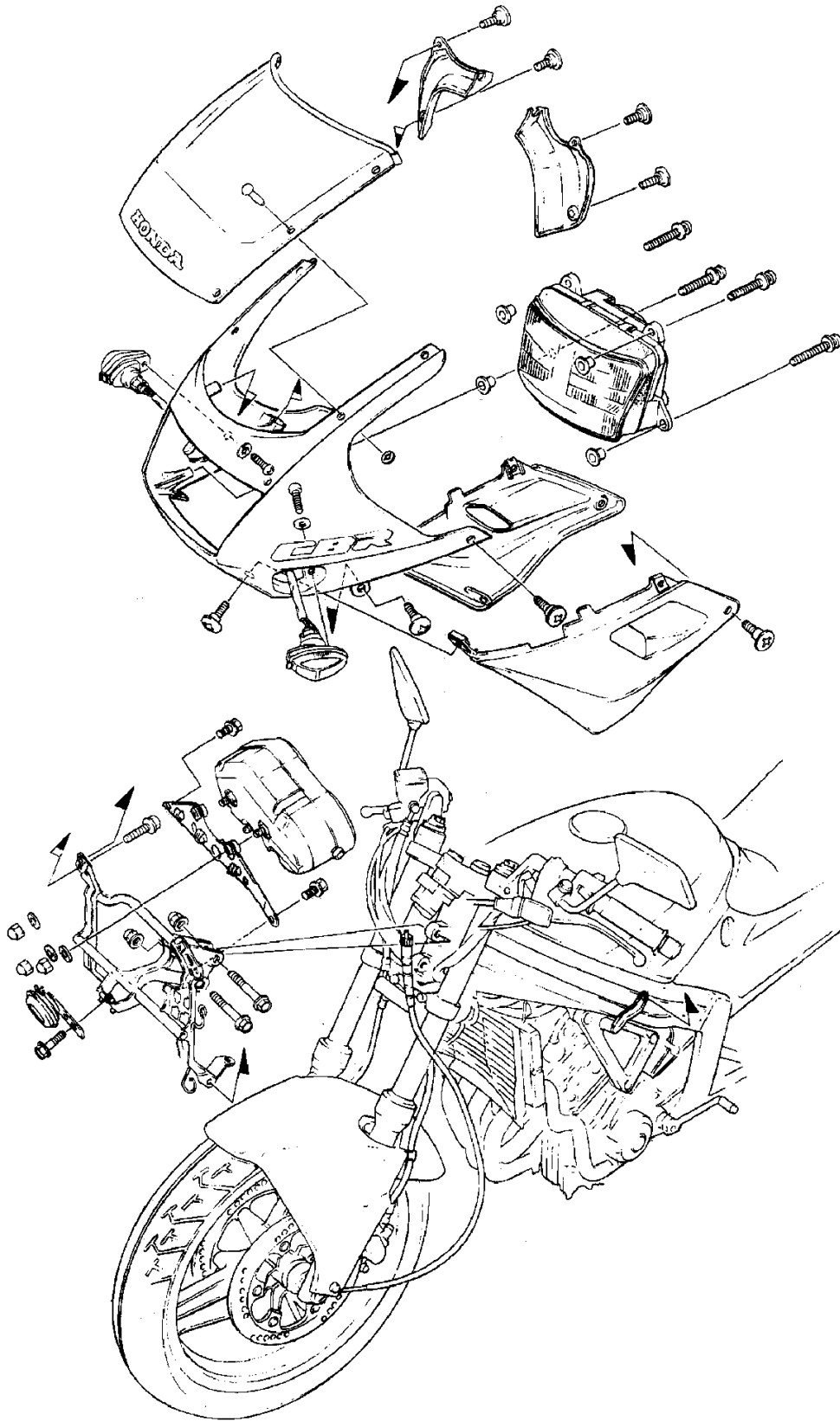

# CBR250R,RR 13. Front Wheel Suspension Steering

Disassembly	13-0	Steering handle	13-6
Service information	13-2	Front wheel	13-10
Troubleshooting	13-3	Front fork	13-16
Fairing	13-4	Steering stem	13-25

- **Service Information**

- **General caution**

- Avoid applying excess force to the wheel. Do not step on it.
- As a tubeless tyre is equipped, handle the tyre and the rim carefully.
- When detaching the tyre from the rim, use exclusive "Tyre lever" and "Rim protector".
- Refer to "Honda Motorcycle tubeless tyre service manual (No. 6041551)" for the tubeless tyre handling.

- **Service**

		Standard	Limitation
Deformation of the front axle		-	0.2mm
Front wheel Deformation	Radial direction	-	2.0mm
	Side direction	-	2.0mm
Front cushion spring natural length		419.9mm	411.5mm
Front fork pipe deformation		-	0.2mm
Front fork Oil	Standard	290 ± 2.5cc	-
	Fully compressed	114mm	-
Front fork air pressure		0-0.4kg / cm <sup>2</sup>	-

- **Torque**

Handle attachment Bolt	2.5-3.0kg-m	Front fork socket bolt	1.5-2.0kg-m
Brake disk bolt	3.7-4.3kg-m	Bottom bridge bolt	3.0-4.0kg-m
Front axle nut	5.5-6.5kg-m	Top bridge bolt	0.9-1.3kg-m
Axle holder nut	1.8-2.5kg-m	Fork bolt	1.5-3.0kg-m
Caliper bracket bolt	2.4-3.0kg-m	Steering adjustment	2.0-2.4kg-m
Master cylinder Holder nut	1.0-1.4kg-m	Steering stem nut	9.0-12.0kg-m
Fairing	0.7-1.1kg-m	Fairing stay	3.0-4.0kg-m
Fairing inside cover	0.6-1.0kg-m	Front fender 6mm bolt	0.8-1.2kg-m
Ignition switch	2.5-3.0kg-m	6mm biss	0.7-1.1kg-m

- **Tools**

- **Exclusive Tools**

Steering stem socket	07916-3710100	1. Driver shaft Assy	07946-KM90300
Fork seal driver	07947-KA20200	2. Assembly base	07946-KM90600
Attachment	07946-MB00000	3. Driver attachment A	07946-KM90100
Steering stem driver	07946-KM90000	4. Driver attachment B	07946-KM90200
Ball race remover set	(1-6 inclusive)	5. Bearing remover A	07946-KM90400
		6. Bearing remover B	07946-KM90500

# CBR250R,RR 13. Front Wheel Suspension Steering

---

## • Common tool

Fork seal driver	07747-0010100	Driver handle A	07749-0010000
Extension bar	07716-0020500	Pilot (15mm)	07746-0040300
Lock nut wrench (30 x 32mm)	07716-002400	Outer driver (42 x 47mm)	07746-0010300
Bearing remover Shaft	07746-0050100	Outer driver (32 x 35mm)	07746-0010100
Bearing remover Head (15mm)	07746-0050400		

## • Troubleshooting

### Heavy Steering

- Steering adjust nut excessively tightened.
- Steering bearing damaged.
- Interference between wires and cables
- Tyre pressure too low.

### Too Light Steering

- Front fork bent.
- Front axle bent, tyre tilted.
- Rear axle bent.

### Front wheel track unstable

- Rim deformed.
- Loose attachment of the front wheel bearing.
- Poor quality tyre.
- Inadequate tightening around the axle.

### Noise from the front cushion

- Contact between a fork pipe and the bottom case.
- Lack of fork oil.
- Cushion attachment bolts loose.

### Front cushion too soft

- Spring distorted.
- Lack of fork oil.
- Inadequate fork air pressure.
- Improper viscosity of oil.

### Front cushion too hard

- Inadequate fork oil.
- Inadequate fork air pressure.
- Fork pipe bent.
- Oil path jammed.
- Inadequate viscosity of oil.

# CBR250R,RR 13. Front Wheel Suspension Steering

- Fairing
- Fairing detachment

Remove attachment screw on a side cowl.

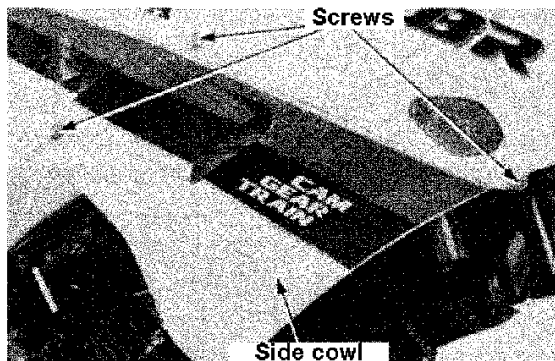

Slide the projection of the side cowl to the position lower than the alignment marking of the radiator and detach the side cowl.

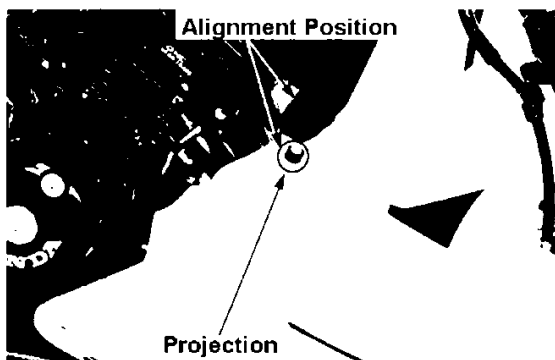

Remove the screw and detach fairing inside cover.

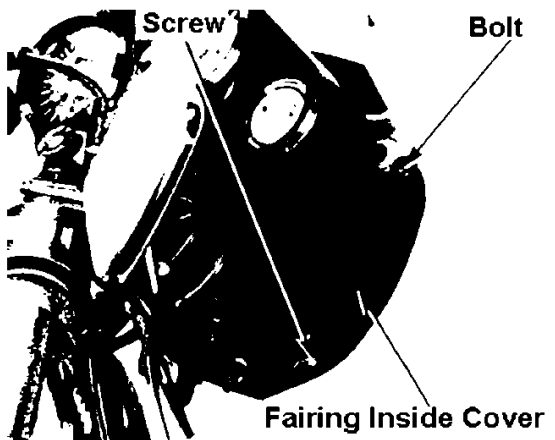

Remove the fairing attachment bolt and the screw from the meter stay.

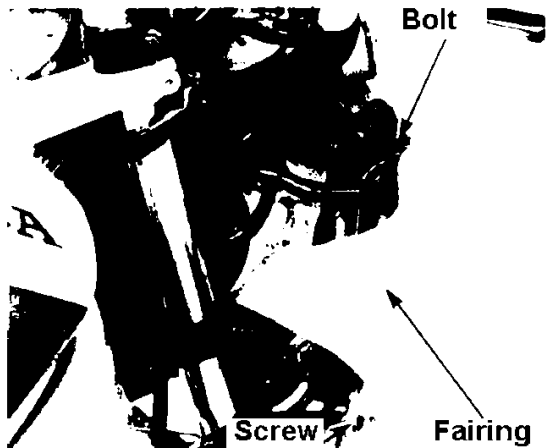

# CBR250R,RR 13. Front Wheel Suspension Steering

---

Remove two screws on lower part of the fairing.  
Pull the fairing forward

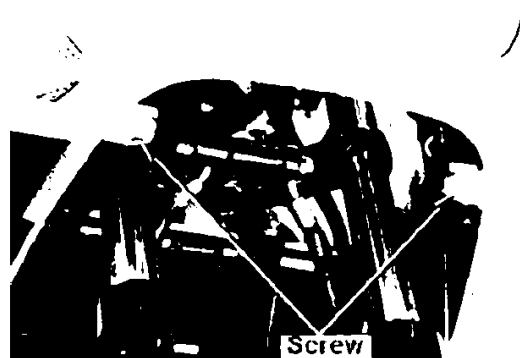

Slide the headlight cover and disconnect the socket.  
Disconnect blinker couplers.

## Fairing attachment

Reverse the detachment procedure.

Torque: Fairing 0.7 ~ 1.1kg-m  
Fairing inside cover 0.6 ~ 1.0kg-m

Align the slit on a fairing inside cover to the steering stay when attaching the cover.

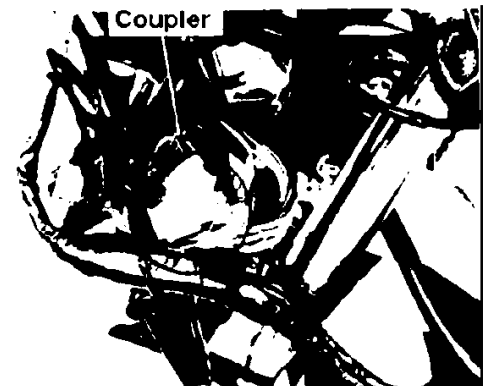
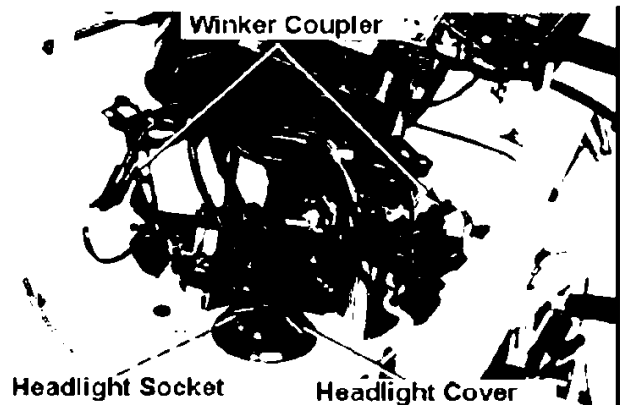

## Steering stay detachment

Detach the fairing (13-4)  
Disconnect the indicators and fuse couplers.  
Detach the indicators (20-3).

Detach the harness from steering stay clamps.  
Disconnect the horn switch wirings.

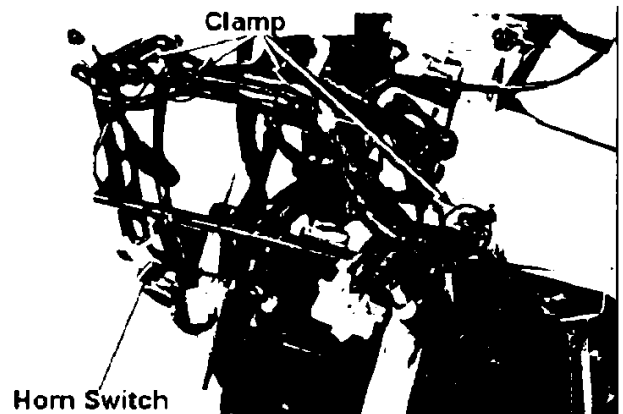

# CBR250R,RR 13. Front Wheel Suspension Steering

Disconnect ignition wires and right handle switch wires from the clamp.  
Remove steering stay attachment bolt/nut and detach the steering stay.



## Steering stay attachment

Reverse the detachment procedure.

Torque: 3.0 ~ 4.0kg-m

Attach the fairing (13-5)

Connect wires, harnesses and couplers correctly (1-22).

## Caution

- Do not suspend the master cylinder by the brake hose.
- Do not turn the master cylinder upside down as it may let air go into the hydraulic systems. Maintain the original position and fix to the body.

## Steering Handle

### Detachment

Detach the following parts:

- Right handle weight
- Handle switch case
- Throttle grip
- Rearview mirror
- Master cylinder
- Left handle lever bracket

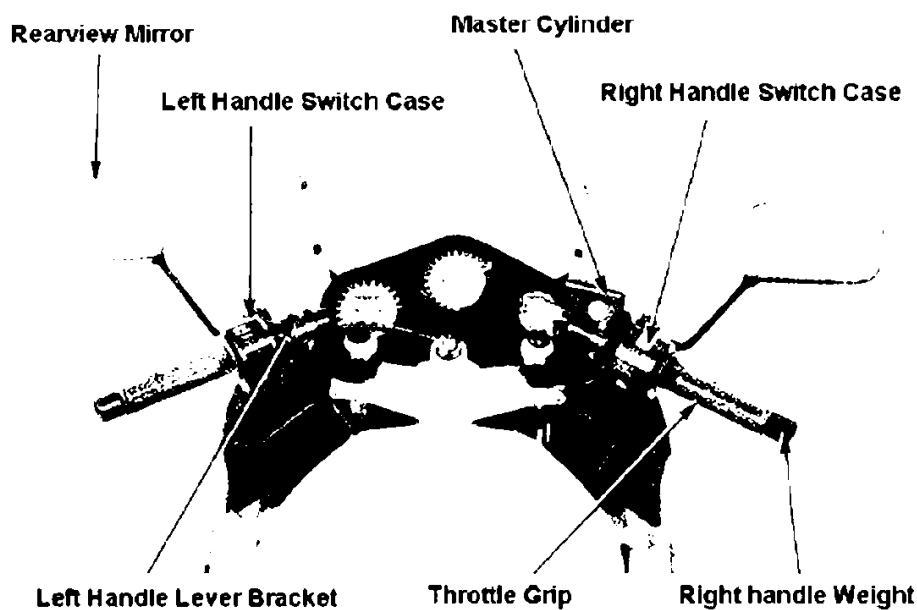

13-6

# CBR250R,RR 13. Front Wheel Suspension Steering

## Left hand detachment

Remove the handle weight and detach the grip and choke lever.  
Detach the stopper ring and remove the handle attachment bolt.  
Detach the left handle from the fork pipe.

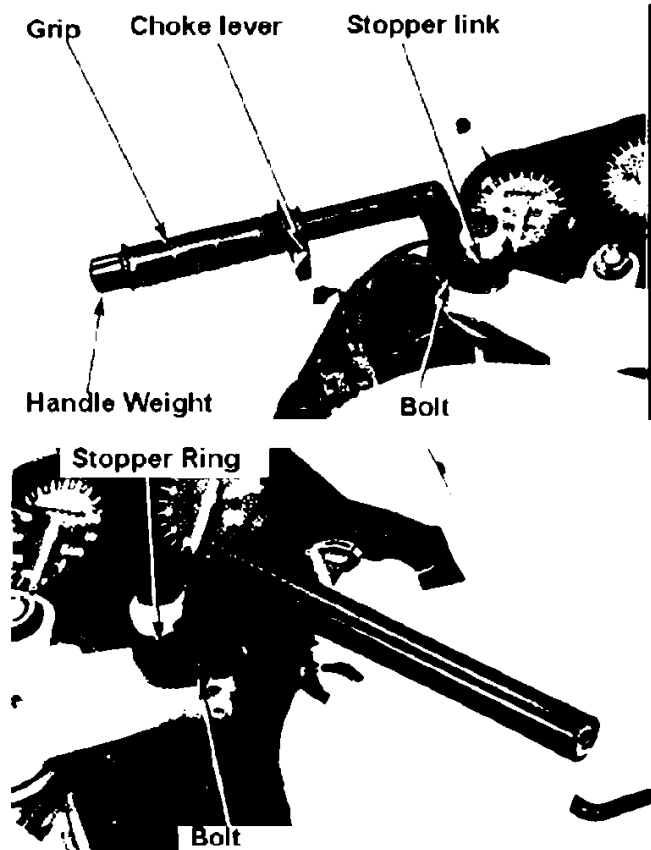

## Right handle detachment

Detach the stopper ring and remove the handle attachment bolt.  
Detach the right handle from the fork pipe.

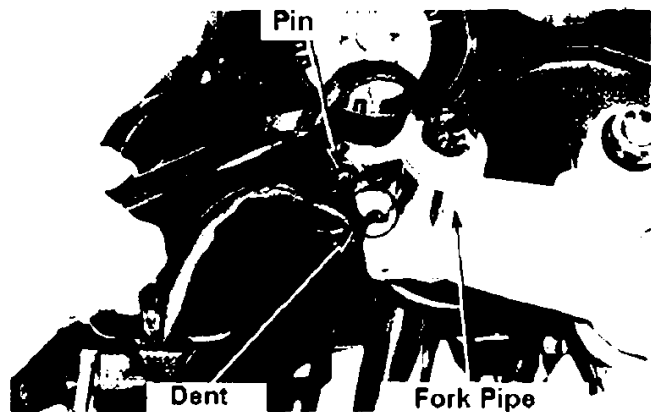

## Left handle attachment

Align the handle position fixing pin with the dent on the top bridge and attach the pin to the fork pipe.

Firmly set the stopper ring to the slit on the fork pipe and tighten the handle attachment bolt. Torque: 2.5 ~ 3.0kg-m

Attach the choke lever to the handle.  
Remove dirt, oil from the left handle grip bonding surface and let it dry.  
Apply genuine Honda "Honda bond A" or "Cemedyne #540" to bonding surface and attach the grip by twisting it.

Allow a couple of hours for bond to dry.

Attach the handle weight.

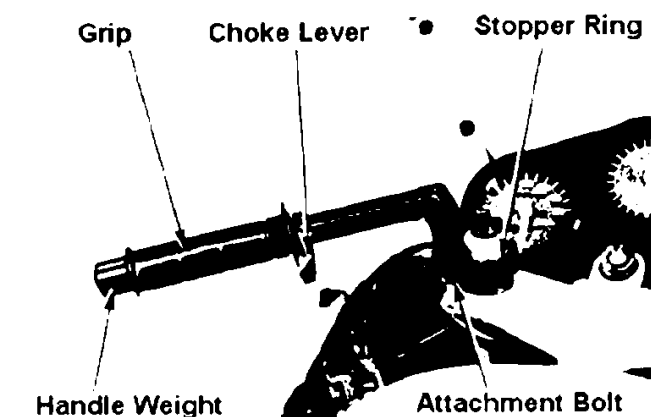



# CBR250R,RR 13. Front Wheel Suspension Steering

Connect the choke cable to the choke lever.

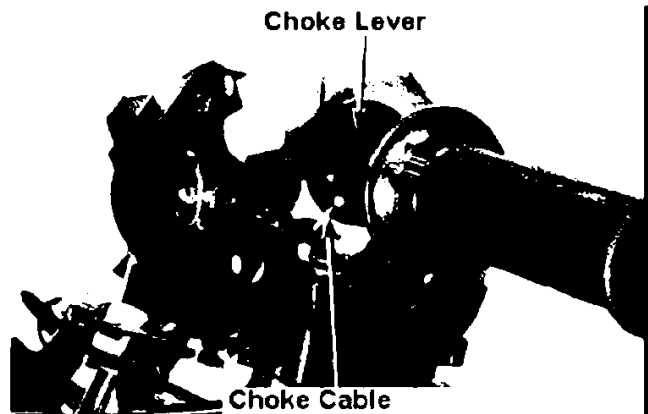

Align the projection on the left switch case with the hole on the handle and attach it.

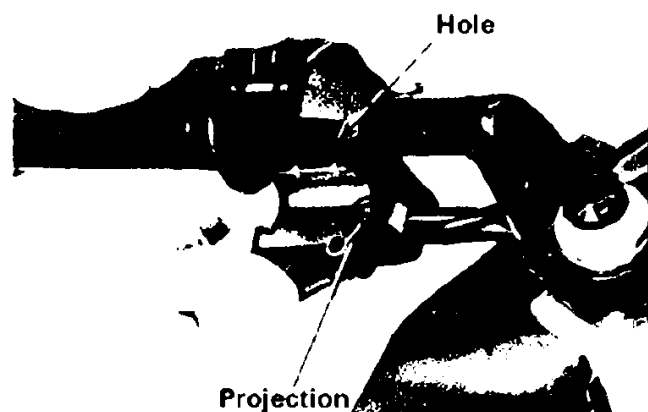

Fix the switchcase with two screws.

Front screws first, then the rear screws second to tighten.

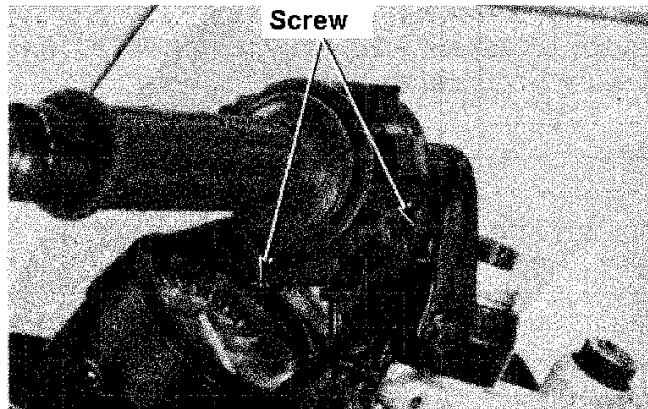

Attach the left handle over bracket and the holder and tighten the bolts.

- Align the alignment surface of the holder to the punched mark on the handle.
- Face the "UP" mark on the holder upwards.
- Tighten the top bolt first, then the bottom one.

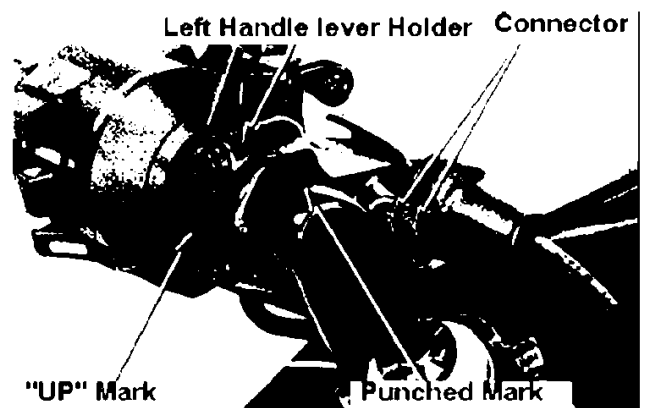

# CBR250R,RR 13. Front Wheel Suspension Steering

## Right handle attachment

Align the handle positioning pin with the slit on the top bridge and attach the pin to the fork pipe.

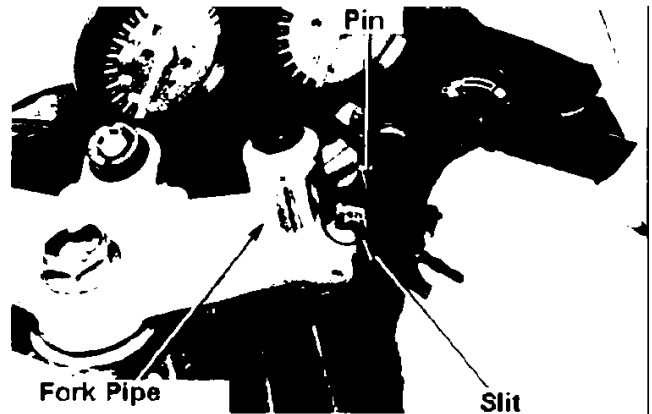

Firmly attach the stopper ring to the slit on the forkpipe.

Tighten the handle attachment bolt.  
Torque: 2.5 ~ 3.0kg-m

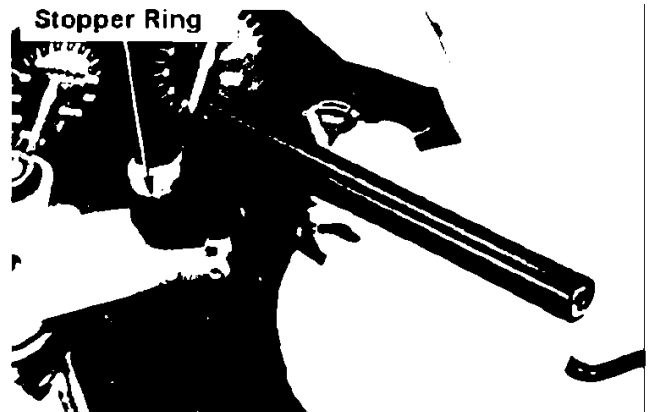

Clean the contact surface for the throttle grip on the handle. Attach the throttle grip.

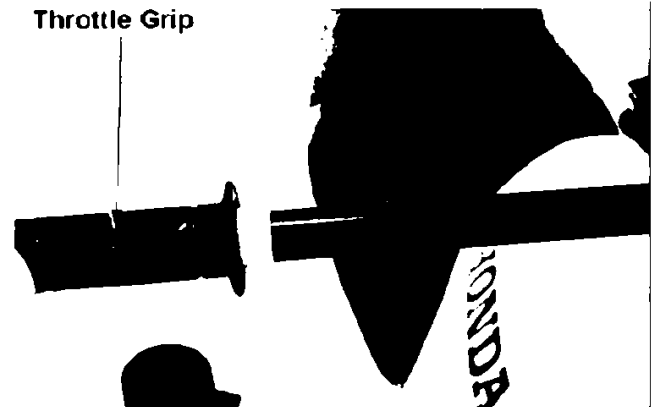

Attach the handle weight.

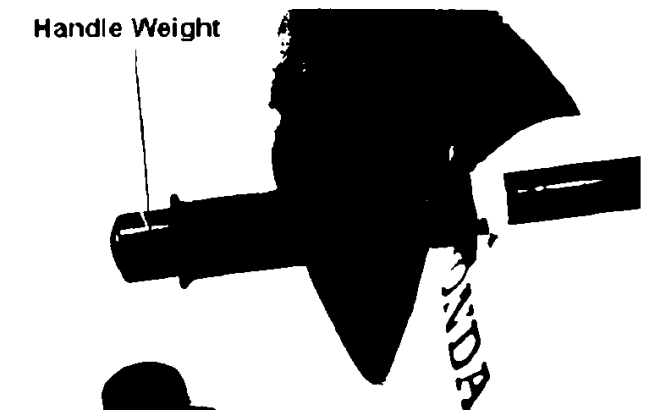

# CBR250R,RR 13. Front Wheel Suspension Steering

Connect throttle cables to the grip.

Align the projection of the right handle switch case and the hole on the handle.

Attach the case to the handle.

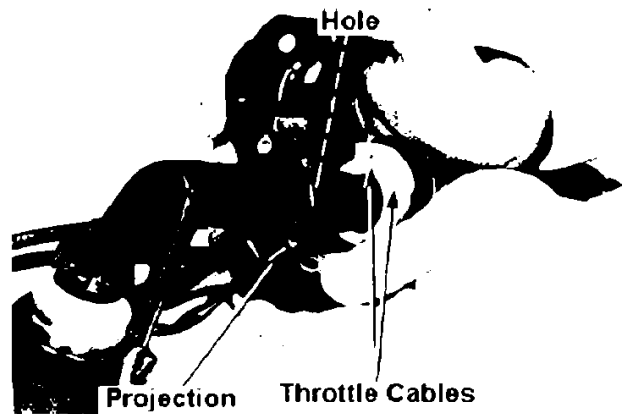

Tighten the front screw for the right handle switch case, then tighten the rear screws.



Face the "UP" making on the holder upwards, attach the master cylinder to the handle.

Align the alignment surface of the master cylinder and the holder with the punched mark on the handle. Tighten the top bolt first, then the bottom one.

**Torque: 1.0 ~ 1.4kg-m**

Connect wires to the front stop indicator switch. Adjust free movement of the throttle grip (2-17).

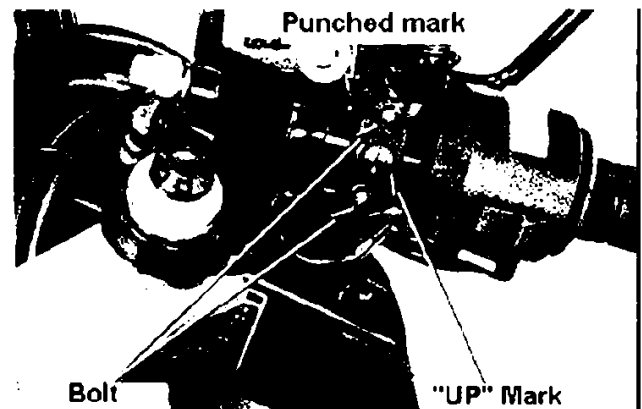

## **Front Wheel Detachment**

Support bottom of the engine and float the wheel.

Remove screws and disconnect speed indicator cables from the gear box.

Remove the brake caliper with the bracket.

Remove nuts and detach right and left axle holders.

Remove the front wheel.

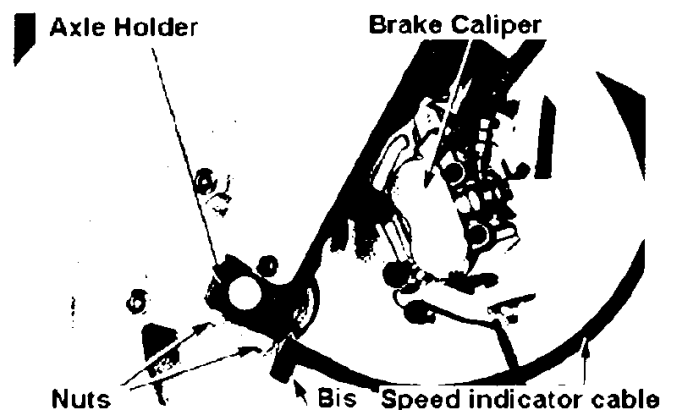

# CBR250R,RR 13. Front Wheel Suspension Steering

## Front axle detachment

Support the axle from speed the indicator gear box side and remove axle nut.  
Detach the front axle and the speed indicator gear box.

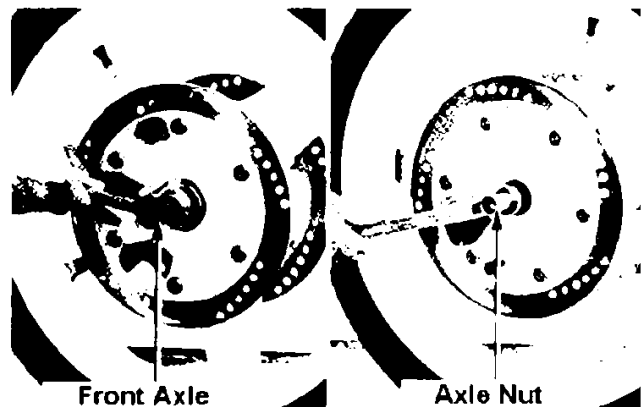

## Inspection

Inspect the front axle for deformation.  
Place the axle on V-blocks and measure with a dial gauge.  
Take half of the indicated value.

$\geq 0.2\text{mm} \rightarrow$  replace

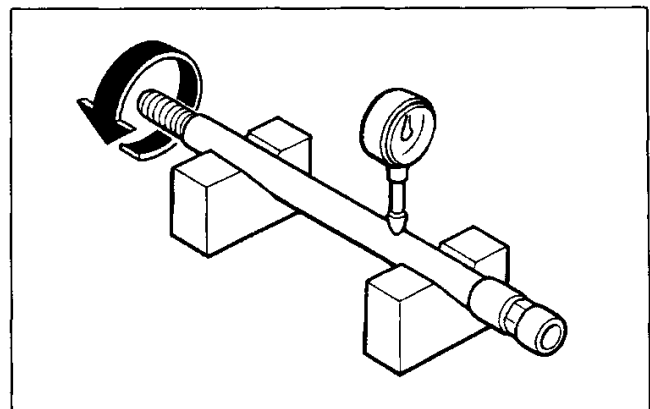

Inspect the wheel for deformation.

Radial:  $\geq 2.0\text{mm}$  )  
Side:  $\geq 2.0\text{mm}$  ) Replace

- You cannot adjust a cast wheel.
- Replace with new wheels, if the limit is exceeded.

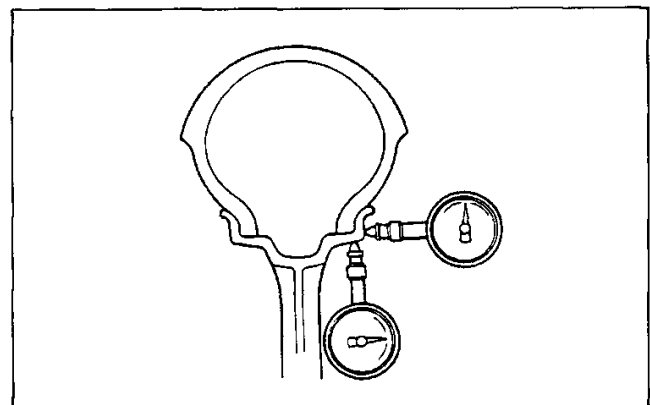

Rotate the bearing inner race by finger and replace if there is a noise or loose fit.

Always replace both sides at the same time.

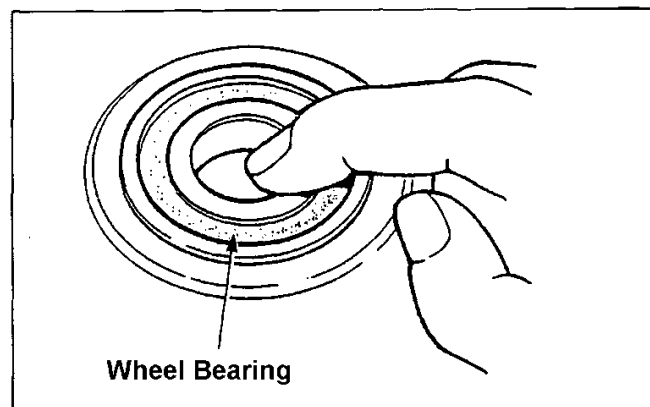

# CBR250R,RR 13. Front Wheel Suspension Steering

## Wheel Balance

### Note:

- Check the balance whenever removing a tyre from the wheel, as the wheel balance does affect the stability, steering and total safety of the vehicle.
- Check the tyre balance mark is aligned with the valve.

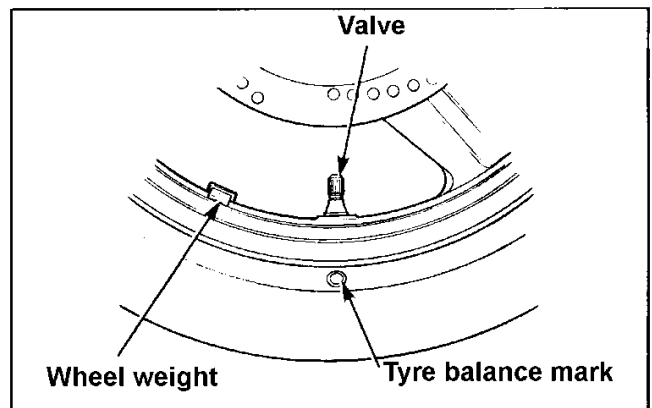

Remove the collar and the speed indicator gear box.

Attach the wheel, tyre and brake disc to an inspection stand.

Spin the wheel and mark the lowest (heaviest) part of the wheel with chalk once it has stopped.

Repeat this for two or three times and find the heaviest part. If the wheel is in balance, there is no specific heaviest part. Temporarily attach a wheel weight to the highest (lightest) part. If the weight is adequate, the wheel will not stop at any particular position.

After confirming the balance, fix the weight.

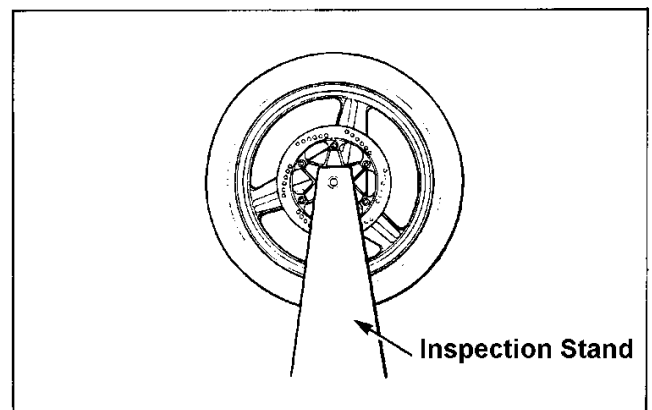

### Caution:

Weight should not exceed 60g for each wheel.

## Disassembly

Remove the speed indicator gear box, dust seal and gear box retainer.

Remove socket bolts and detach the left brake disc.

Remove the wheel collar and the dust seal from right side.

Remove socket bolts and detach the right brake disc.

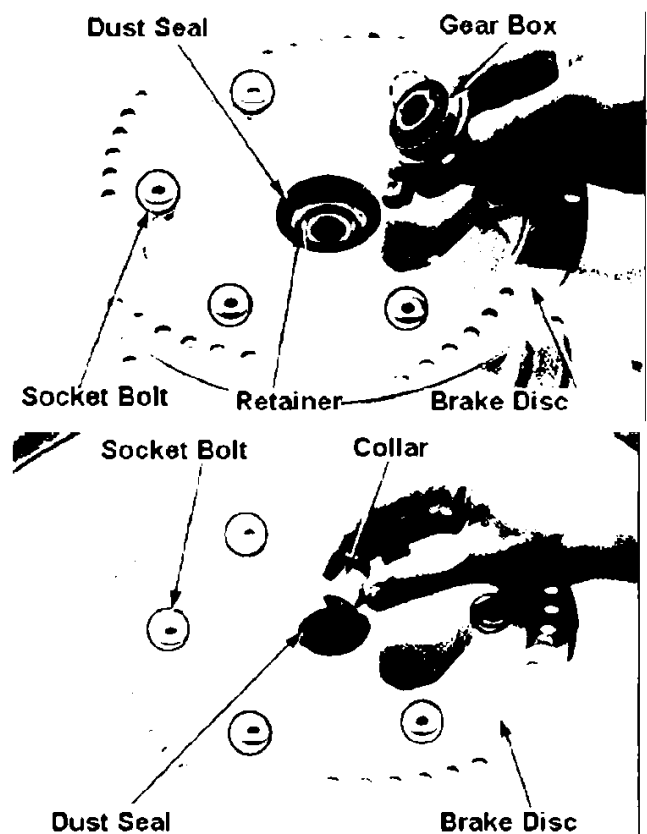

## Bearing detachment

# CBR250R,RR 13. Front Wheel Suspension Steering

Detach the bearing and the distance collar.

### Common Tools

- Bearing remover shaft 07746-0050100
- Bearing remover head 07746-0040300

### Assembly

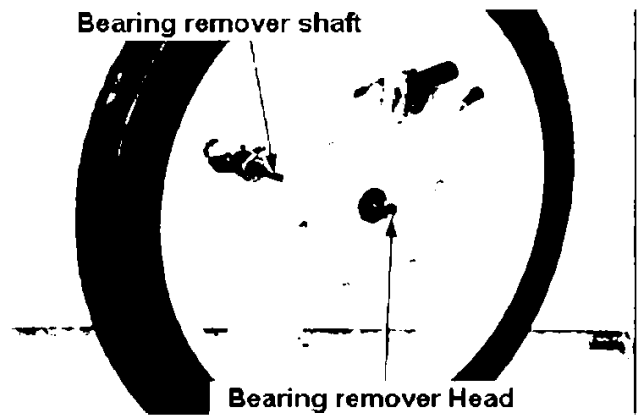

Never let oil/grease touch the brake disk as it may result in reducing break performance. Wipe any dirt off from the disk.

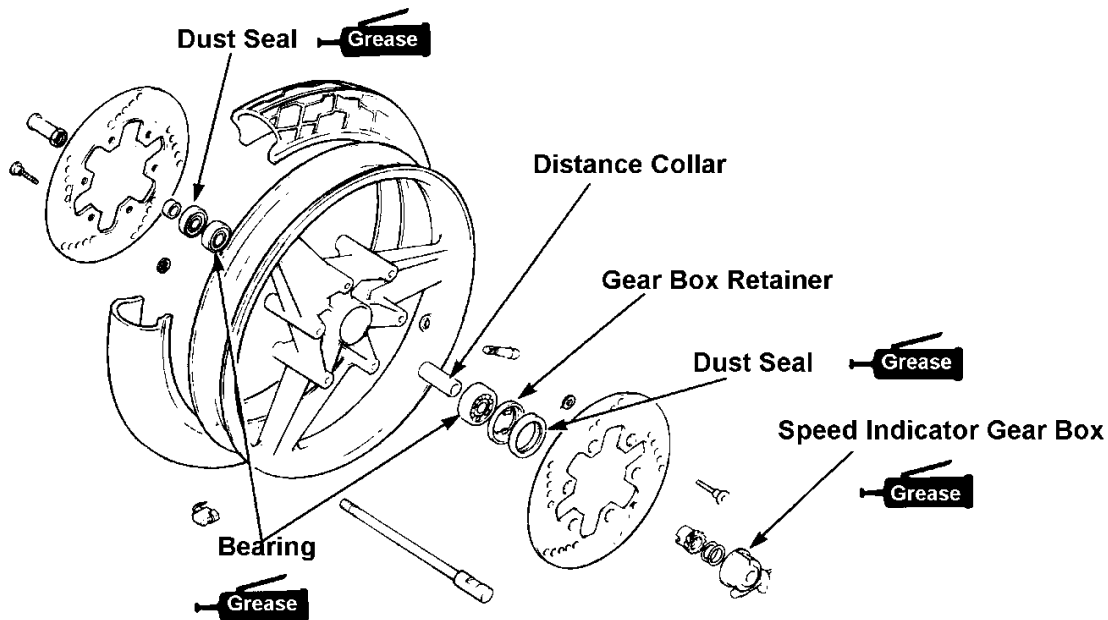

Bearings should be set parallel.  
Set the right bearing and attach the distance collar.

Check the position of the distance collar before attaching the bearings.

Set the left bearing.

### Common tools

- Driver handle A 07749-0010000
- Pilot (15mm) 07746-0040300
- (L) Outer driver (42x47mm) 07746-0010300
- (R) Outer driver (32x35mm) 00746-0010100

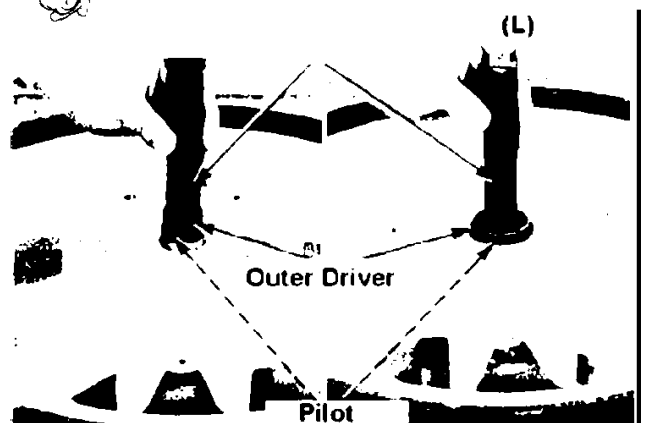

# CBR250R,RR 13. Front Wheel Suspension Steering

Attach brake disc shims to the right wheel hub.

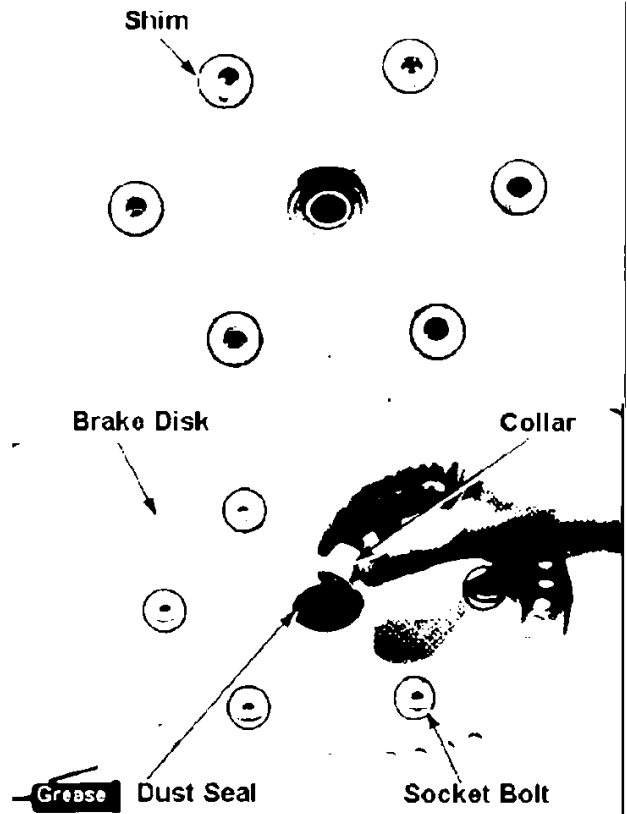

Attach the right brake disc with six socket bolts.

**Torque: 3.7 ~ 4.3kg-m**

Attach the dust seal and wheel collar to the right hub.

Attach the gear box retainer to the left wheel hub by aligning the projection on the retainer with the slits on the hub.

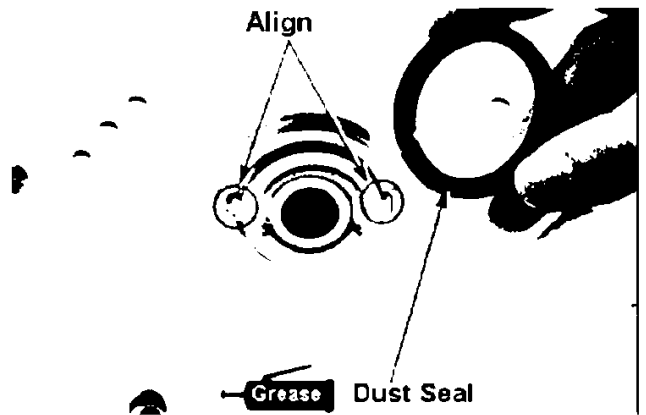

Attach the dust seal.

Attach brake disc shims to the left wheel hub.

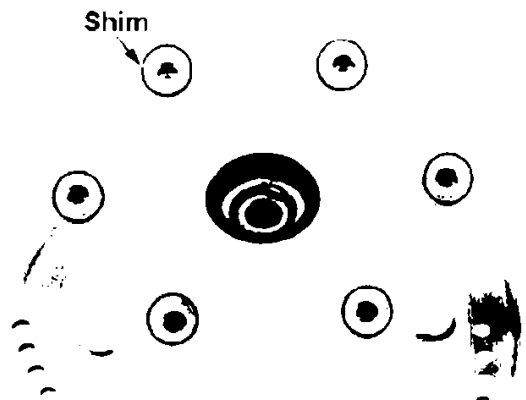

# CBR250R,RR 13. Front Wheel Suspension Steering

Apply grease to the speed indicator gear box, washer and gear.

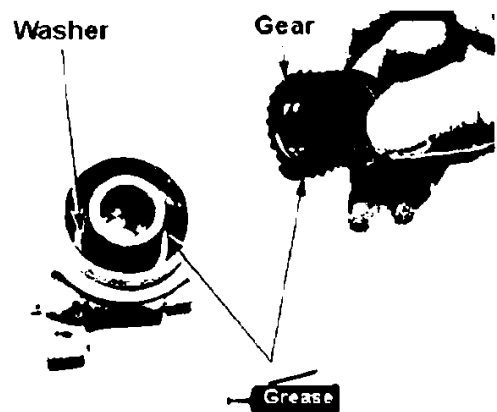

Attach the left brake disc with six socket bolts.

**Torque: 3.7 ~ 4.3kg-m**

Attach the speed indicator gear box and the retainer to the gear by aligning the projection of the box and the retainer with the slits on the gear.

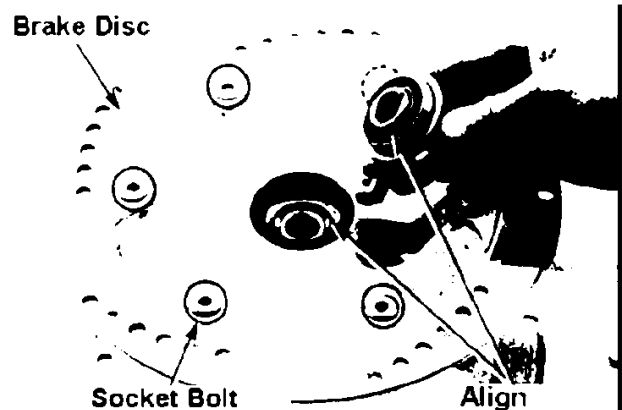

Insert the front axle from the speed indicator gear box side and tighten axle nut.

**Torque: 5.5 ~ 6.5kg-m**

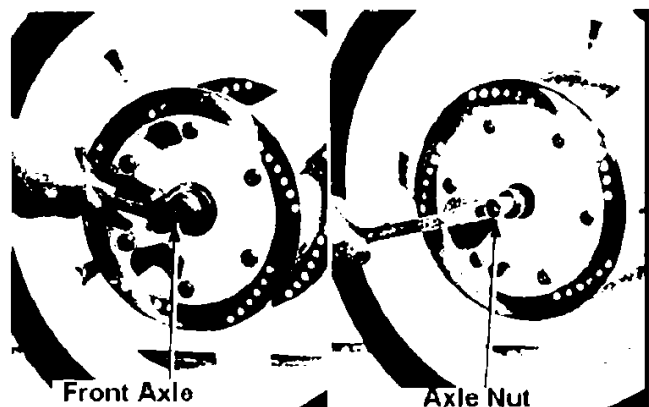

## Attachment

Set the brake disc between brake pads and set the front wheel.

Align the stopper of the speed indicator gear box with the rear part of the stopper on a left fork bottom case.

Set the arrow symbol on the axle holder forward and attach.

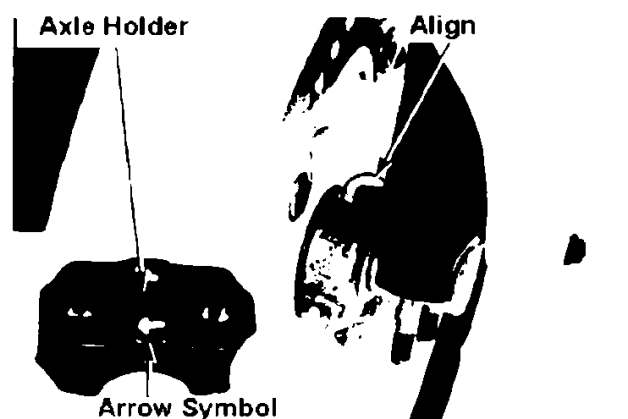



# CBR250R,RR 13. Front Wheel Suspension Steering

Tighten the front nut on the right axle holder and then tighten the rear nut.

**Torque: 1.8 ~ 2.5kg-m**

Attach the caliper and tighten the caliper bracket bolt.

**Torque: 2.4 ~ 3.0kg-m**

Do not damage the brake pads.

Connect the speed indicator cable to the gear box and tighten the screw.

Measure the clearance between the left brake disc and the caliper bracket with a 0.7mm thickness gauge.

If you cannot insert the gauge, pull the left fork outward until the gauge fits in. Check the clearance is at least 0.7mm on both sides of the left brake disc. Tighten the front nut on the left axle holder first, then the rear nut.

**Torque: 1.8 ~ 2.5kg-m**

Operate the brake lever for several times and inspect the clearance between the caliper bracket and the disk on both sides.

Insufficient clearance may damage the disc.

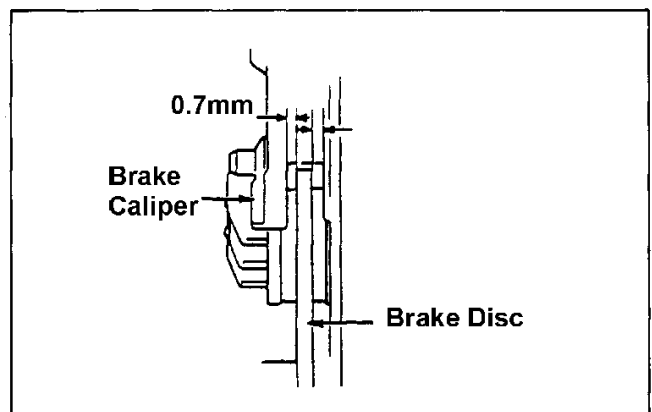
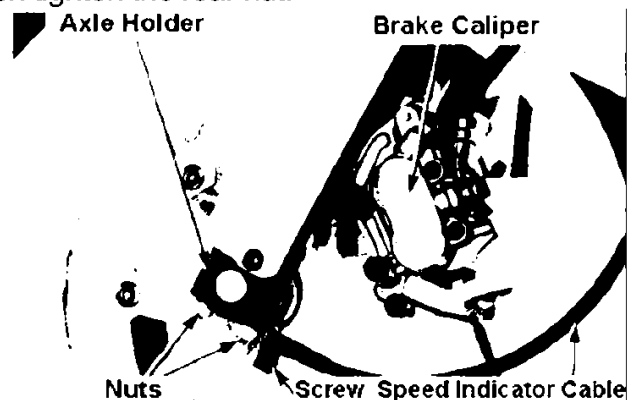

## Front Fork

### Detachment

Remove the front wheel (13-10)

Remove the brake caliper with the bracket.

Remove front fender attachment bolts and screws.

Detach the front fender.

Detach the steering handle (13-6)

### Caution

- Do not suspend the front brake master cylinder with the brake hose.
- Do not turn the master cylinder upside down. It may let air enter the hydraulic system. Maintain the attached position and fix to the body.

Remove the air valve cap. Push the air valve to drain air in the front fork.

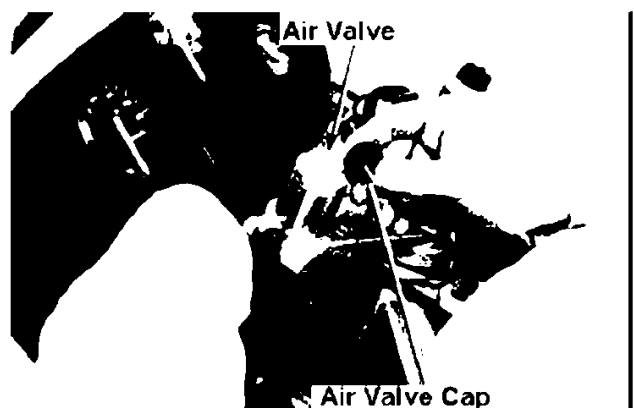
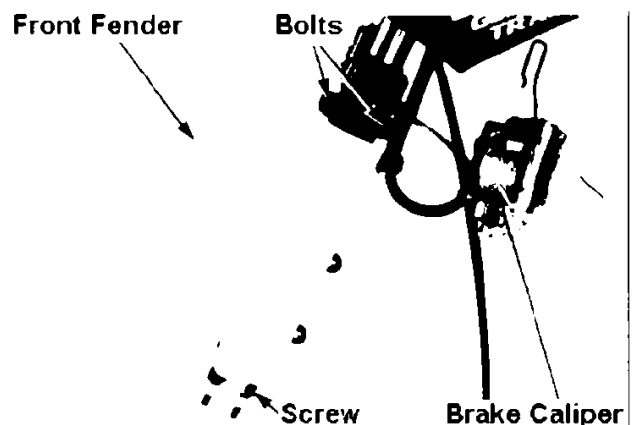

# CBR250R,RR 13. Front Wheel Suspension Steering

---

Loosen the fork bolt.  
Loosen the top bridge bolt.

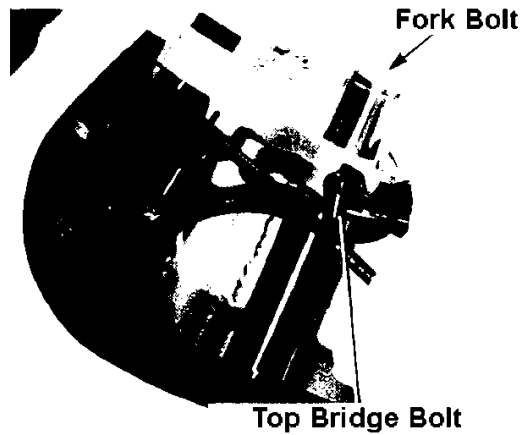

Loosen the bottom bridge bolt.  
Remove the front fork.

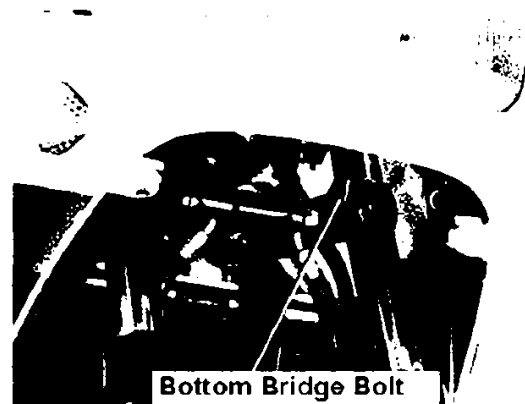

## Disassembly

Remove the fork bolt.

- When using a vice, use a cloth to avoid damaging the fork pipe.
- Avoid the contact area of the pipe when setting to a vice.

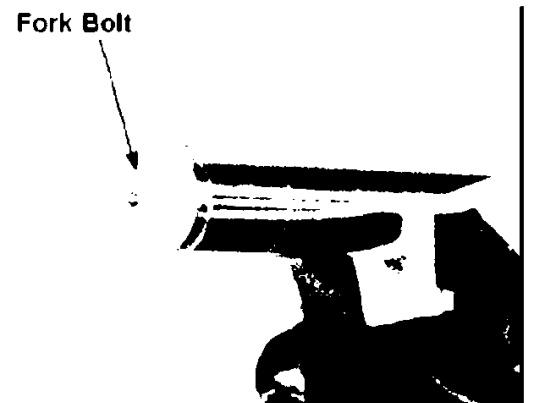

Remove the spacer, spring seat and the spring.  
Drain oil by compressing the front fork for several times.

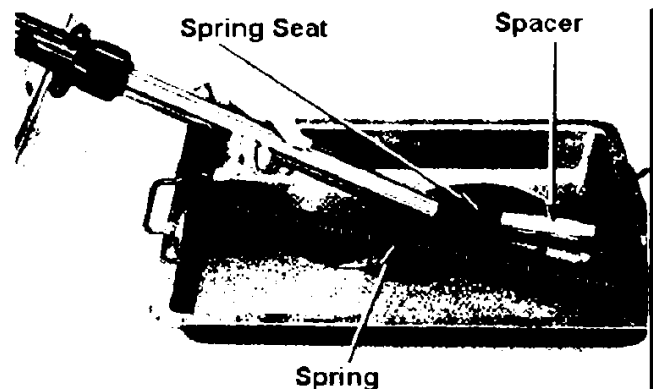

# CBR250R,RR 13. Front Wheel Suspension Steering

Fix the fork bottom case to a vice by applying a cloth. Remove the socket bolt.

- If the socket bolt is spinning and won't come out, temporarily attach the spring and a fork belt.

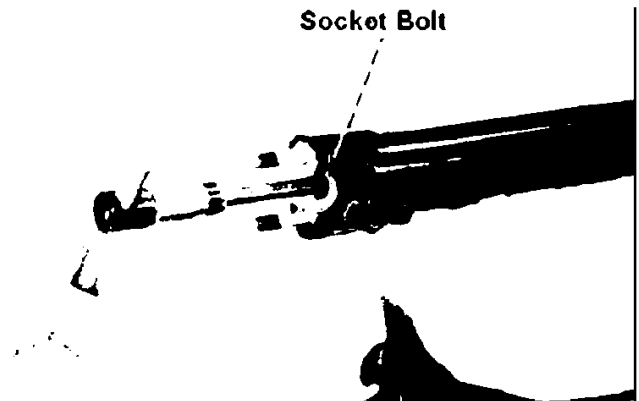

Detach the dust seal and the snap ring.

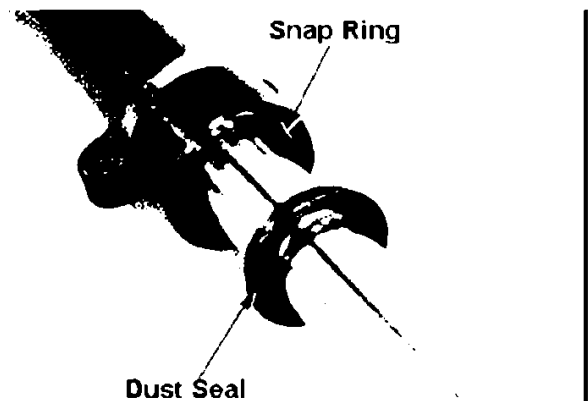

Pull the fork pipe out from the bottom case.

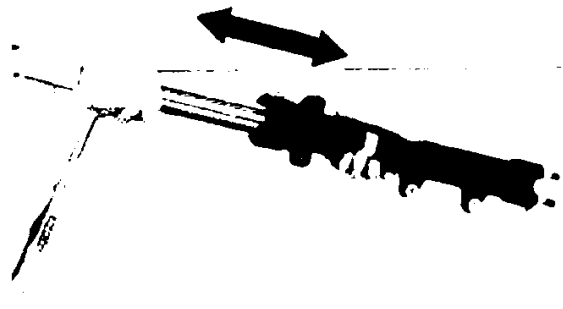

Remove the oil lock pin from the bottom case. Detach an oil seal, back up ring and the guide bush from the fork pipe.

Do not detach the fork pipe bush unless replacing with a new one.

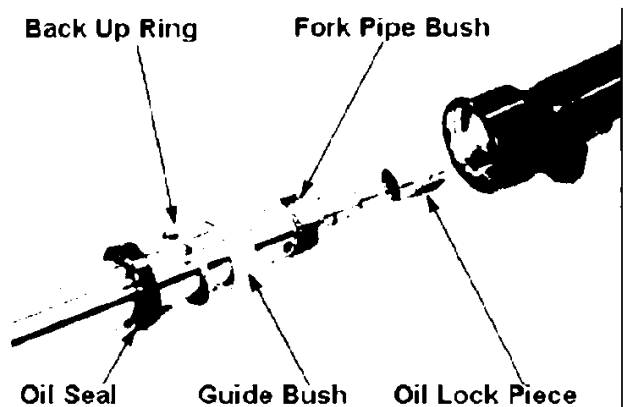

# CBR250R,RR 13. Front Wheel Suspension Steering

Remove the stopper ring.  
Detach the seat pipe from the fork pipe.

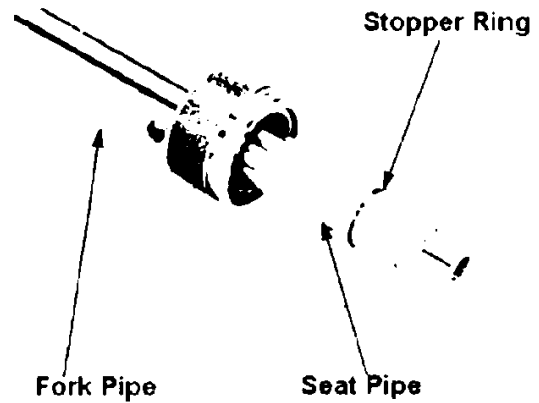

## Inspection

Measure the relaxed length of the fork spring.

$\leq 411.5\text{mm}$  → Replace

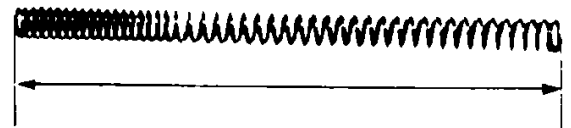

Inspect each part for damage, unusual wear and replace as required.

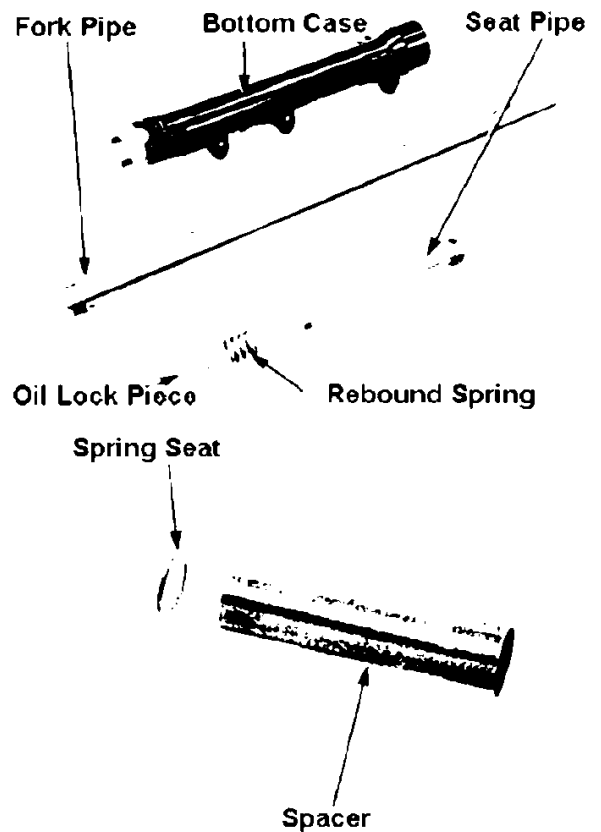

Inspect the spacer and the spring seat for damage and replace if necessary.

# CBR250R,RR 13. Front Wheel Suspension Steering

Place the fork pipe on V-blocks and measure the bend of the pipe with a dial gauge.

Take half of the indicated value.

$$\leq 0.2\text{mm} \rightarrow \text{Replace}$$

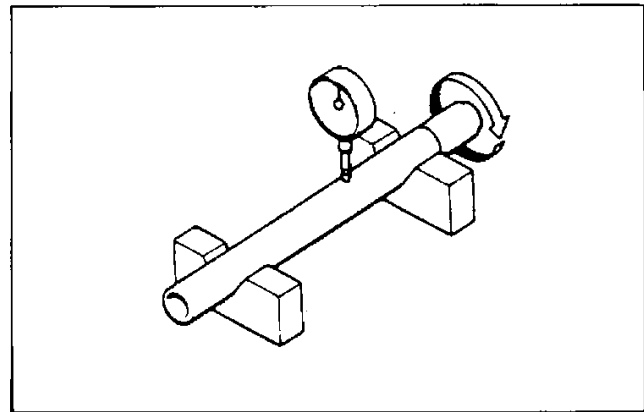

Visually inspect the contact part of the guide bush and the fork pipe bush. Replace if the surface coating has peeled off for more than  $\frac{3}{4}$  of the contact area. The peeled area can be identified as an area if copper is exposed.

Replace where subsequent scratch is found as well.

Inspect the backup ring and replace if deformation is found.

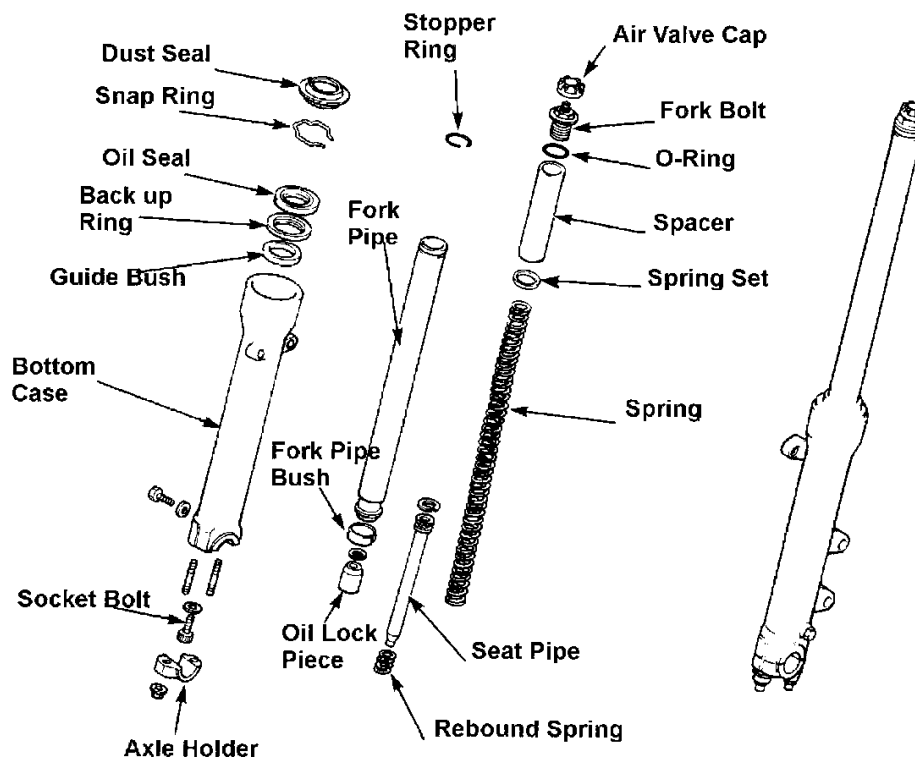
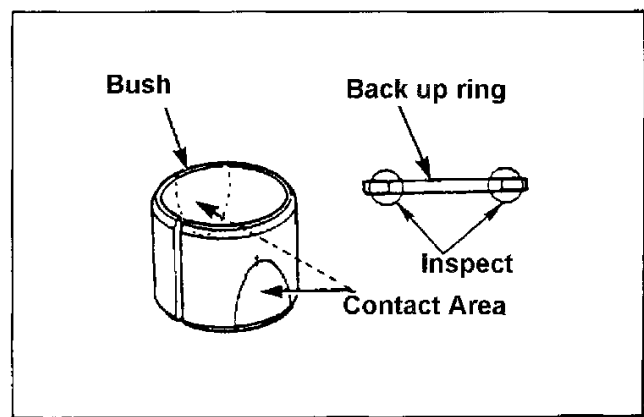

# CBR250R,RR 13. Front Wheel Suspension Steering

Insert the rebound spring and the seat pipe to the fork pipe.

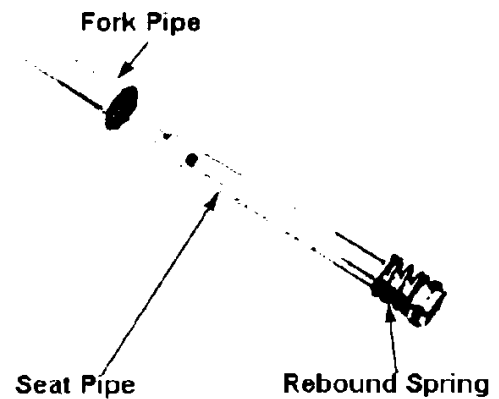

Attach the stopper ring to the seat pipe.

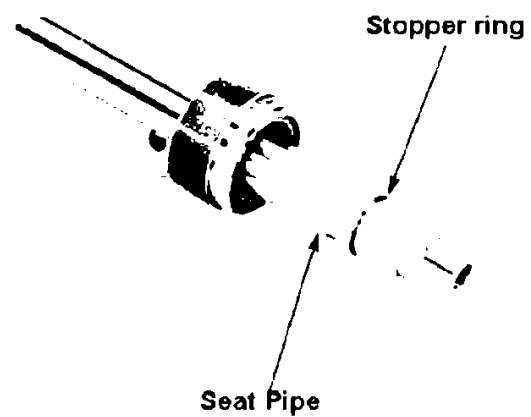

Attach the guide bush and the backup ring to the fork pipe.

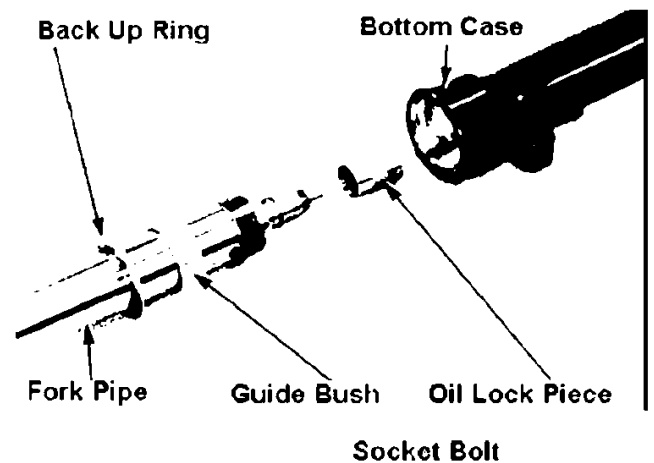

Attach oil lock piece to the seat pipe.  
Insert the fork pipe to the bottom case.

Apply cloth around the bottom case and fix the case to a vice.

Tighten the socket bolt to the seat pipe.

**Torque: 0.5 ~ 2.0kg-m**

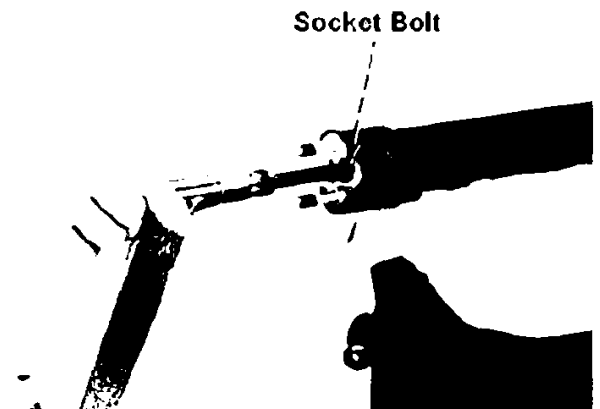

# CBR250R,RR 13. Front Wheel Suspension Steering

Apply ATF to the lip of the oil seal.

- When installing the oil seal, apply vinyl tape to the top end of the fork pipe in order to avoid damaging the oil seal lip.
- Manufacturer's name on the seal should face up.

Fork Seal Driver Body

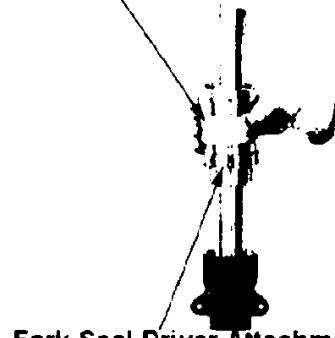

Fork Seal Driver Attachment

Install the guide bush and the oil seal to the bottom case at the same time by using a fork seal driver.

**Exc. tool** Fork seal driver attachment  
07947-KA20200

**Common tool** Fork seal driver body  
07747-0010100

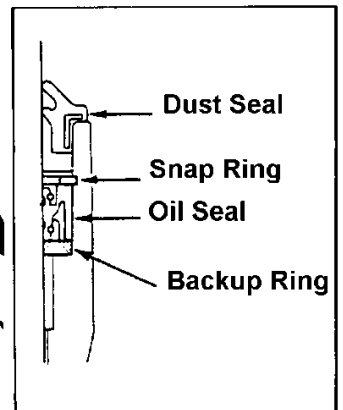
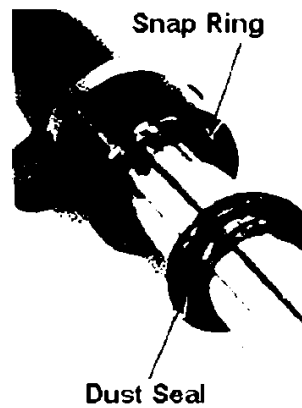

Attach the snap ring.  
Attach the dust seal.

Firmly set the snap ring to the slit of the bottom case.

Fully compress the fork pipe and fill with ATF to the standard level.

**Standard level:** 114mm  
**Capacity:** 290 ± 2.5cc

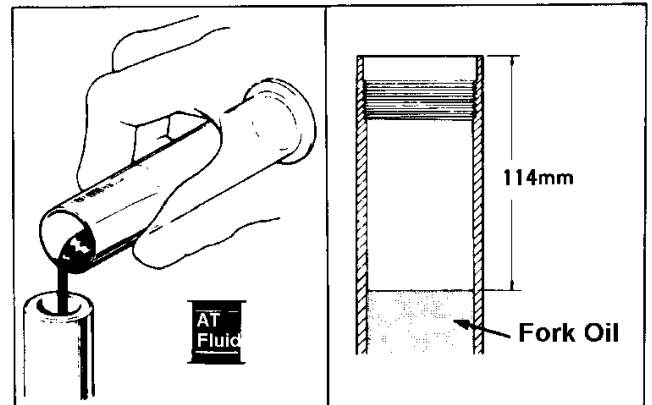

Attach the cushion spring to the fork pipe.

- Wipe all ATF off from the spring before attaching.
- The narrow pitch is the bottom.



# CBR250R,RR 13. Front Wheel Suspension Steering

Attach the spring seat and the spacer to the fork pipe.

Install O-Ring to fork bolt and temporarily attach to the fork pipe.

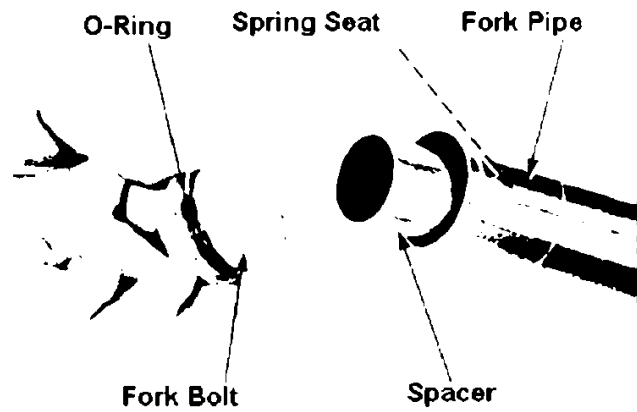

## Attachment

Attach the front fork.

Align the slit on the lower part of the fork pipe with the top surface of the top bridge.

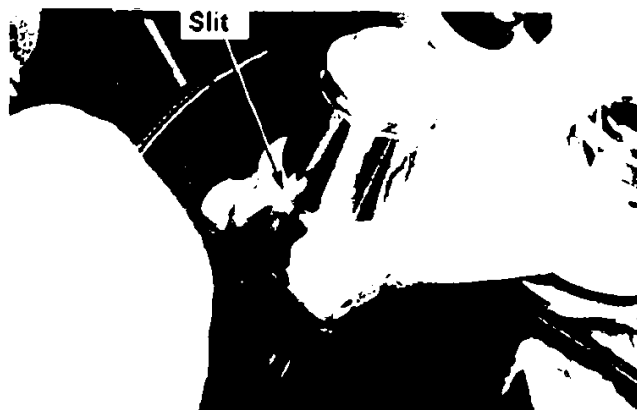

Tighten the top bridge bolt.

Torque: 0.9 ~ 1.3kg-m

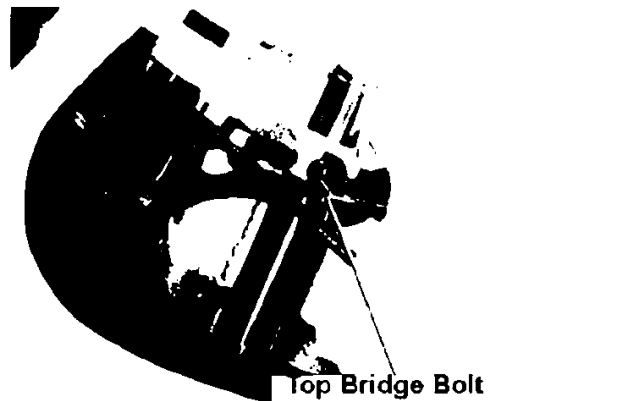

Tighten the bottom bridge bolt.

Torque: 3.0 ~ 4.0kg-m





# CBR250R,RR 13. Front Wheel Suspension Steering

Tighten the fork bolt.

Torque: 1.5 ~ 3.0kg-m

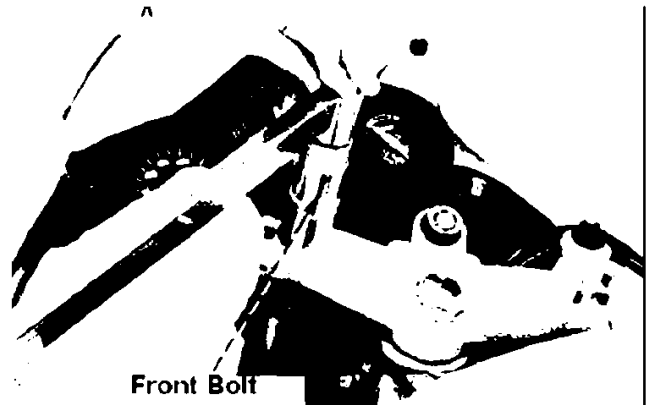

Adjust the air pressure of the front fork (2-7).  
Attach the air valve cap to the fork bolt.

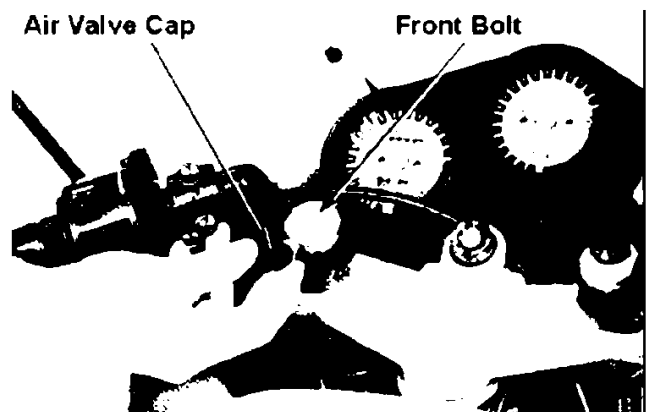

Tighten the screw and fix the front fender with the front fork.

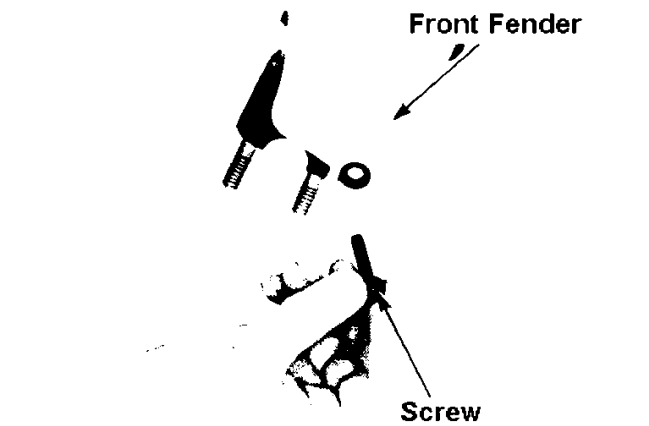

Tighten the front fender attachment bolt.

Torque: 6mm bolt 0.8 ~ 1.2kg-m  
6mm screw 0.7 ~ 1.1kg-m

Attach the brake caliper

Torque: 2.4 ~ 3.0kg-m

Attach the front wheel (13-15).

Attach the steering handle (13-7).

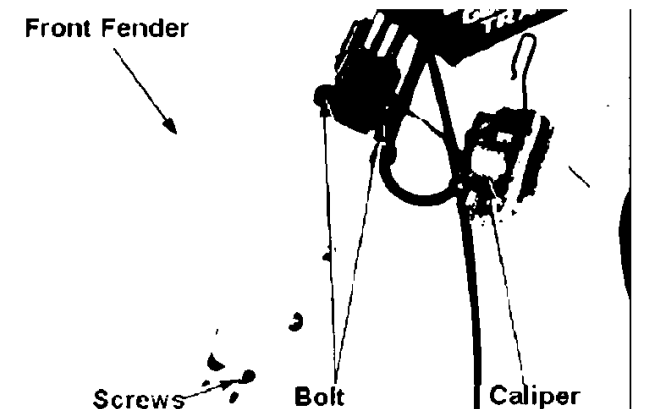

# CBR250R,RR 13. Front Wheel Suspension Steering

- **Steering Stem**

## Detachment

Detach the steering handle (13-6).  
Remove the front wheel (13-10).  
Remove two attachment bolts and detach the ignition switch.

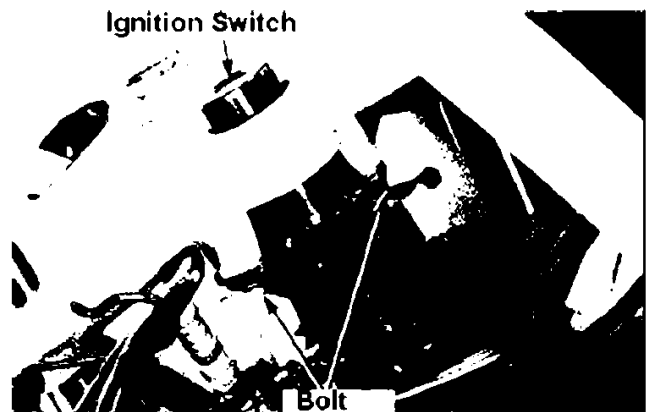

Detach the steering stem nut and the washer.

### Common tool

Lock nut wrench 30 x 32mm  
07716-0020400

Extension bar  
07716-0020500

Remove front forks (13-16).

Detach fork top bridge.

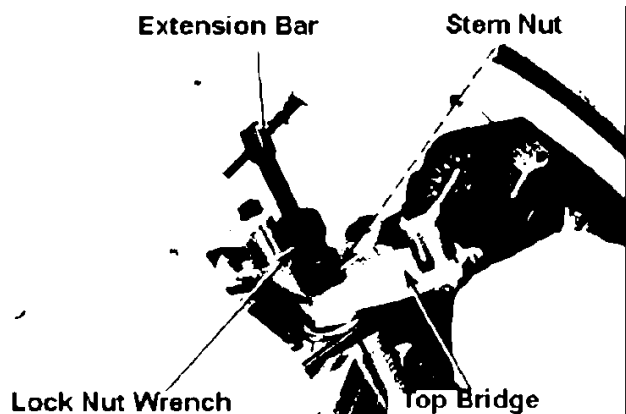

Straighten the catch of the lock washer.

Remove the lock nut and the lock washer.

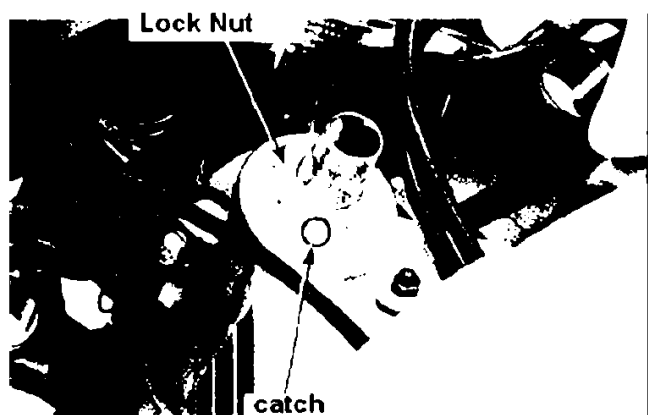

Remove the steering adjust nut.

### Exc. tool

Steering stem socket  
07916-3710100

### Common tool

Extension bar  
07716-0020500

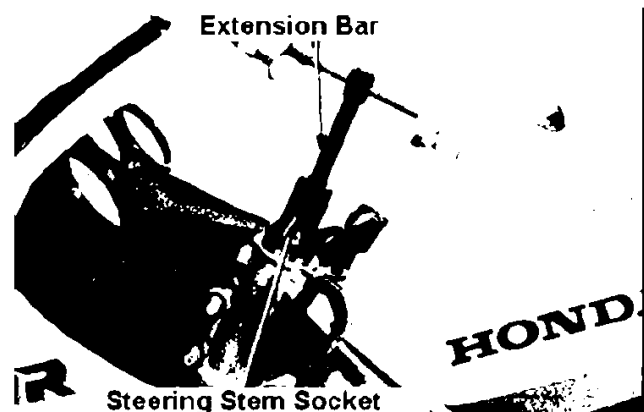

# CBR250R,RR 13. Front Wheel Suspension Steering

Detach the front brake two-way joint.



Remove the steering stem, dust seal, upper bearing inner race and an upper bearing.

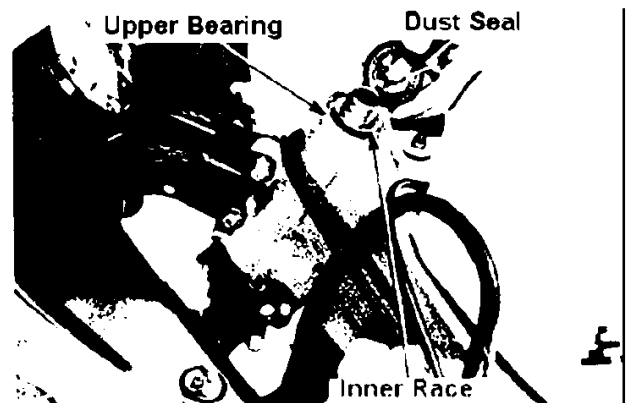

Detach the lower bearing from the stem.

## Inspection

Inspect upper and lower bearings for wear and damage.

Inspect the inner race and the dust seal on lower bearing for wear and damage.

Inspect the bearing outer race of the steering head pipe for wear and damage.

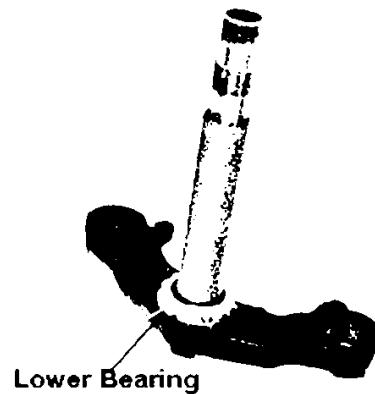

## Bearing Replacement

Replace inner and outer races together with the bearing.

Detach the lower bearing inner race.

- Attach the stem nut to the stem to protect the thread.
- Do not damage the stem.

Remove the dust seal.

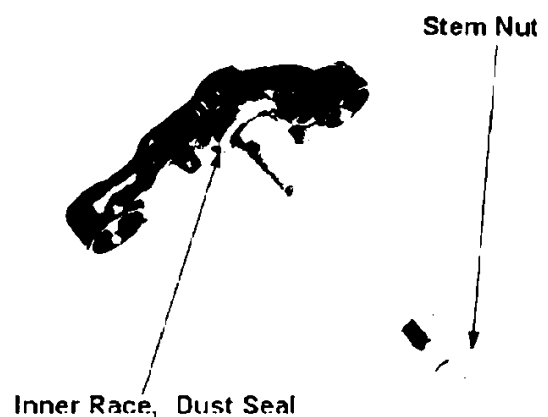

# CBR250R,RR 13. Front Wheel Suspension Steering

Attach the new dust seal to the steering stem and press the inner race in.

Exc. tool      Steering stem driver  
07946-MB00000

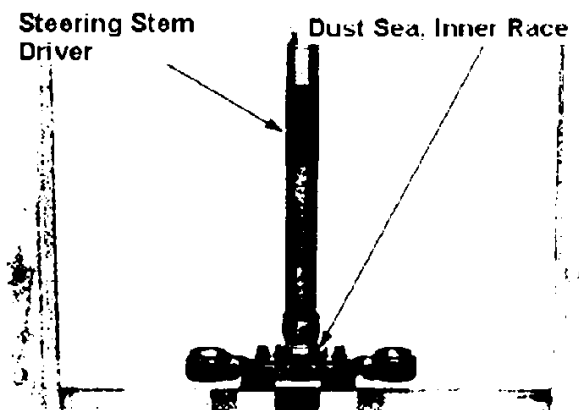

## Ball Race Replacement

Exc. tools

Ball race remover set (incl. 1-6)  
07946-KM90000

- |  |               |
|--|---------------|
| 1. Driver shaft Assy<br>(incl. Nuts A&B) | 07946-KM90300 |
| 2. Assembly base                         | 07946-KM90600 |
| 3. Driver attachment A                   | 07946-KM90100 |
| 4. Driver attachment B                   | 07946-KM90200 |
| 5. Bearing remover A                     | 07946-KM90400 |
| 6. Bearing remover B                     | 07946-KM90500 |

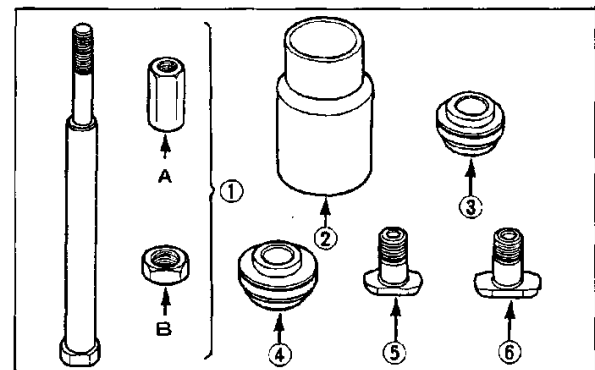

Set a ball race remover to head pipe as shown in the figure.

- Align the bearing remover A with the slit on the head pipe.
- Lightly tighten the nut B.
- Watch out the direction of an assembly base.

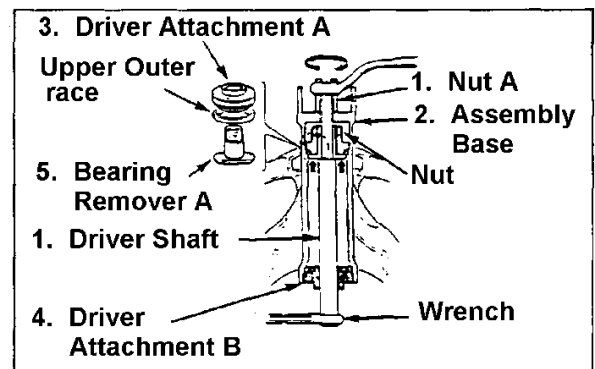

Hold the driver shaft with the wrench and remove the upper outer race by loosening the nut A.

Remove the lower outer race in same manner.

- Align the bearing remover B with the slit on the head pipe to attach.

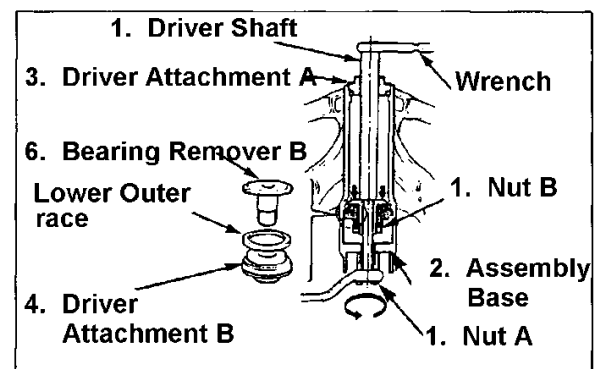

Set the upper outer race and the ball race remover to the head pipe as shown in the figure.

# CBR250R,RR 13. Front Wheel Suspension Steering

Hold the driver shaft with a wrench and attach the upper outer race by gradually rotating the nut A.

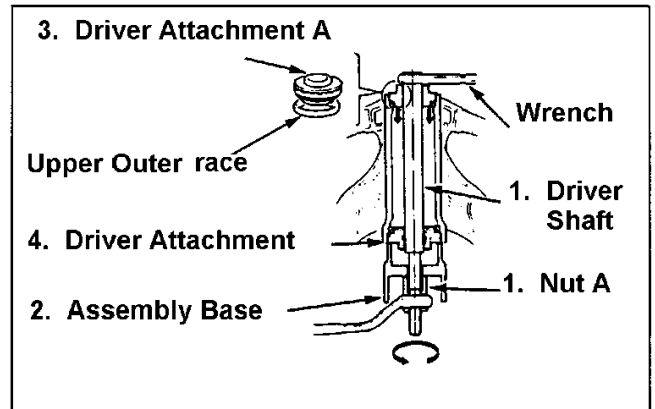

Attach the lower outer race in the same manner.

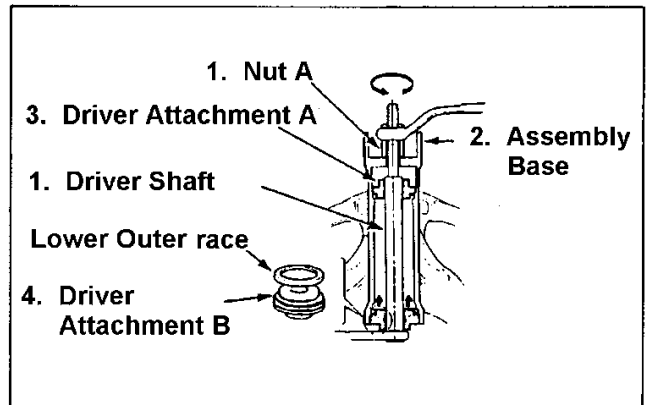

## Attachment

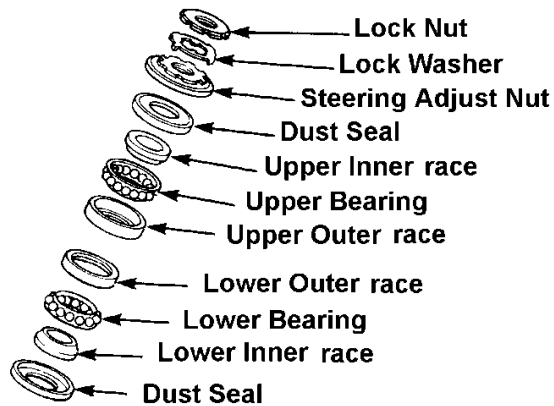
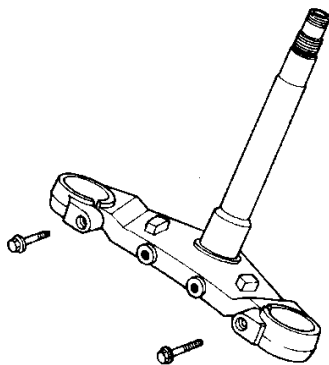

Apply enough grease to the bearing.

Attach the lower bearing to the steering stem.



# CBR250R,RR 13. Front Wheel Suspension Steering

Attach the steering stem to the steering head.

Attach the upper bearing, inner race and the dust seal.

Tighten the steering adjust nut.

**Torque: 2.0 ~ 2.4kg-m**

Exc. tool

Steering stem socket  
07916-3710100

Common tool

Extension bar  
07716-0020500

Steer full deflection both ways 5 ~ 6 times to smooth the bearings on the stem.

Re-tighten the steering adjust nut to specified torque.

Attach the front brake two-way joint.

Attach the catch of the new lock washer to the slit of the steering, adjust nut and attach the washer.

Tighten the lock nut until it touches the lock washer by hand.

Hold the steering, adjust nut and tighten the lock nut enough to align the catch of the lock washer with the slit on the lock nut.

Bend the catch of the lock washer to the slit of the lock nut.

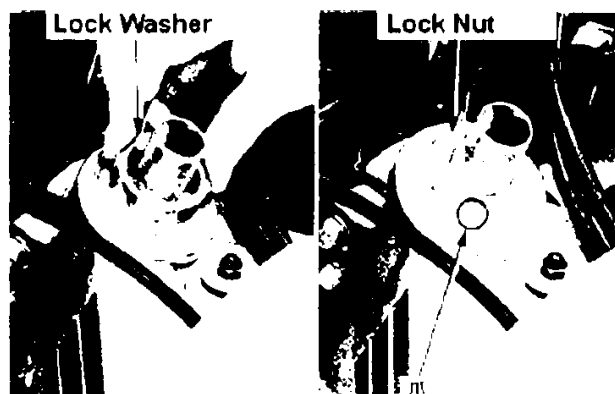
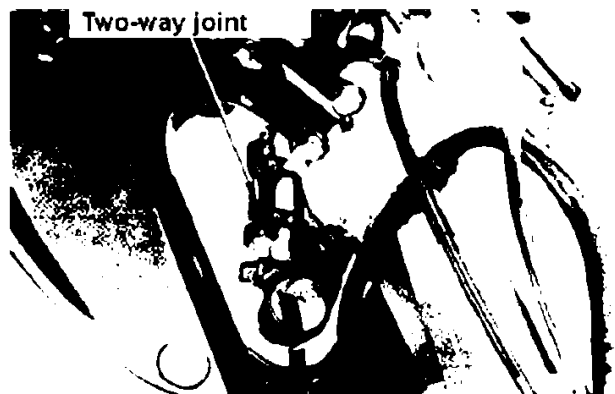
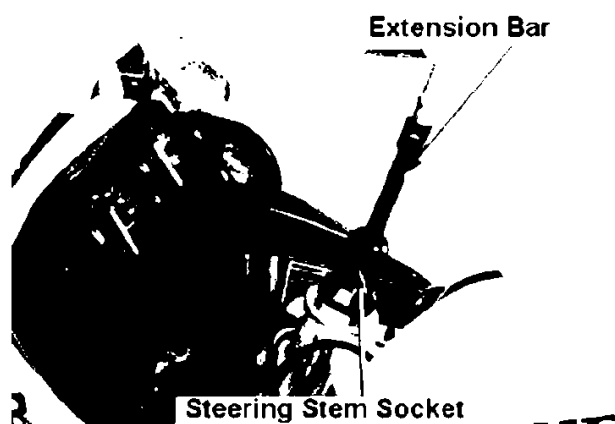
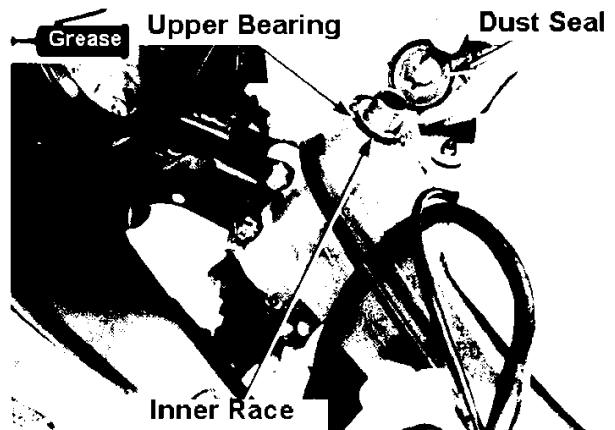

# CBR250R,RR 13. Front Wheel Suspension Steering

Attach the front fork temporarily.  
Attach the fork top bridge.  
Attach the washer and the stem nut and tighten.

**Torque: 9.0 ~ 12.0kg-m**

Attach the front fork correctly (13-23).

Common  
tool

Lock nut wrench (30 x 32mm)  
07716-0020400

Extension bar  
00716-0020500

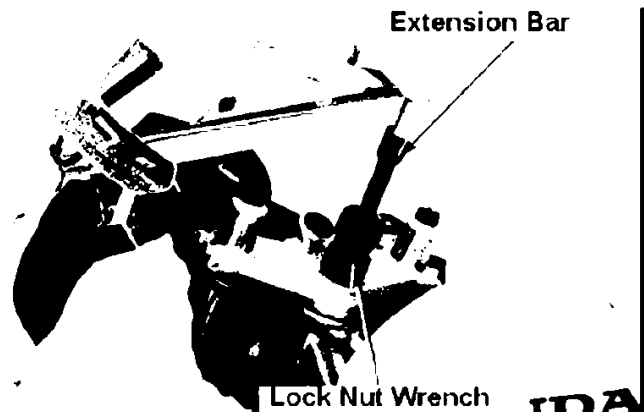

Attach the ignition switch to the top bridge and tighten the two bolts.

**Torque: 2.5 ~ 3.0kg-m**

Attach the front wheel (13-15)  
Attach the steering handle (13-7).

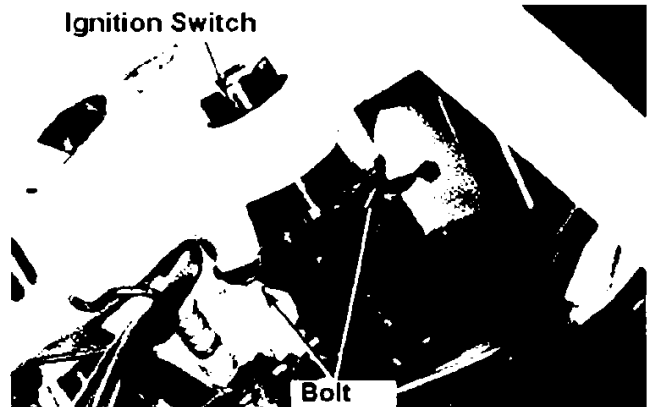

## Steering Load

Support the bottom of the engine and lift the front wheel off.

Straighten the steering stem.

Apply a spring scale to the front fork pipe and measure the load when the steering begins to move.

- Do not obstruct cables, wires or harnesses with the stem.
- Pull perpendicular to the steering top bridge.

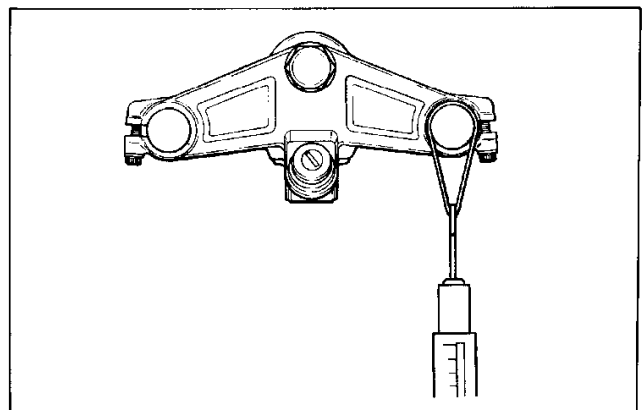

Adjust the tightening of the steering bearing adjustment nut to bring the average of both left / right forks of 1.1kg ~ 1.6kg.

# CBR250R,RR 14. Rear Wheel, Brake & Suspension

- Disassembly

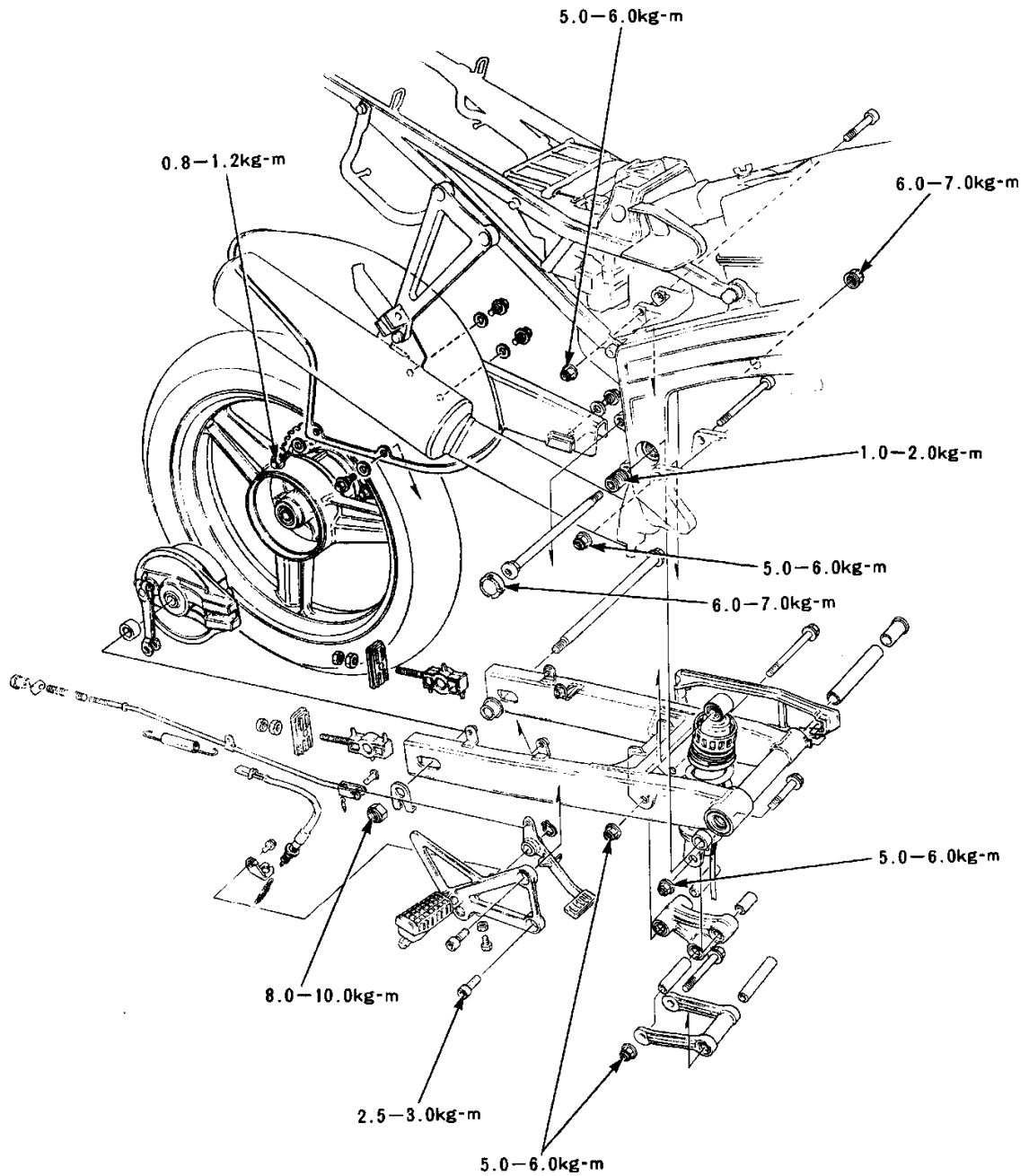



# CBR250R,RR 14. Rear Wheel, Brake & Suspension

Disassembly	14-0	Brake pedal	14-10
Service information	14-1	Rear cushion	14-11
Troubleshooting	14-2	Suspension linkage	14-15
Rear wheel	14-3	Rear fork	14-18
Rear brake	14-7		

## Caution

- Follow the safety instructions as the damper unit of the shock absorber is filled with highly pressurized nitrogen gas.
  - Do not heat or disassemble the damper unit or it may explode or spill the oil.
  - Drain the gas from the damper unit when disposing of the shock absorber.
  
- Do not step on the wheel or apply excess force on the wheel.
- Exercise caution not to damage the wheel.
- Exercise caution not to damage the tyre or rim as a tubeless tyre is equipped.
- When detaching the tyre from the rim, use “tyre lever” and “rim protector”.
- Refer to “Honda Motorcycle Tubeless Tyre Service Manual” (No. 6041551) when detaching / attaching the tubeless tyre.
- Use only specified products for the rear suspension linkage and the rear cushion attachment bolts / nuts. Use caution to the direction of the bolts.
- Refer to 13-12 for balancing the rear wheel.

## • Service Standard

Item		Standard	Limitation
Rear axle bend		-	0.2mm
Rear wheel rim deformation	Radial	-	2.0mm
	side	-	2.0mm
Brake drum inner diameter		140mm	141mm
Brake lining thickness		4.0mm	2.0mm
Rear cushion damper compression		12.3-16.0kg	9.8kg
Rear cushion spring attachment length		173.8mm	-
Rear cushion spring natural length		189.9mm	186.0mm

## • Torque

Driven sprocket nut	2.8-4kg-m	Conrod bolt (cushion arm side)	5.0-6.0kg-m
Rear axle nut	8.0-10kg-m	frame side	5.0-6.0kg-m
Rear cushion lower joint lock nut (apply screw locking liquid)	3.8-6.0kg-m	Rear fork pivot adjust bolt	1.0-2.0kg-m
Rear cushion upper bolt	5.0-6.0kg-m	Rear fork pivot lock nut	6.0-7.0kg-m
Rear cushion lower bolt	5.0-6.0kg-m	Rear fork pivot nut	6.0-7.0kg-m
Cushion arm bolt	5.0-6.0kg-m		

# CBR250R,RR 14. Rear Wheel, Brake & Suspension

Stop holder	2.5-3.0kg-m		
-------------	-------------	--	--

## Tools

### • Exclusive Tools

Needle bearing remover	07GMD KT70200	Outer driver (28x30mm)	07946-1870100
Bearing remover	07936-3710300	Driver shaft	07946-MJ00100
remover handle	07936-3710100	Rear cushion compressor Attachment	07959-MB10000
remover sliding weight	07741-0010201		

### • Common tools

Outer driver (32 x 35mm)	07746-0010100	Pilot (22mm)	07746-0041000
Outer driver (37 x 40mm)	07746-0010200	Bearing remover shaft	07746-0050100
Outer driver (42 x 47mm)	07746-0010300	Bearing remover head (17mm)	07746-0050500
Outer driver (24 x 26mm)	07746-0010700	Driver handle A	07749-0010000
Pilot (15mm)	07746-0040300	Rear cushion compressor	07959-3290001
Pilot (17mm)	07746-0040400		

### • Troubleshooting

#### Vibration of the rear wheel

- Rim deformed
- Loose rear wheel bearing
- Bad quality tyre
- Insufficient tightening around the axle
- Insufficient tyre air pressure
- Rear fork pivot bearing failure

#### Rear cushion too soft

- Spring deformed
- Inadequate adjustment of the rear cushion adjuster
- Rear damper getting loose

#### Rear cushion too hard

- Inadequate adjustment of the rear cushion adjuster
- Damper rod bent

#### Noise from a rear cushion

- Cushion case touching something
- Loose tightening

#### Loose brake

- Inadequate brake adjustment
- Dirt/damage on the brake shoe surface
- Brake shoe cam worn out
- Brake cam worn out
- Brake drum worn out
- Brake arm collation attachment failure

# CBR250R,RR 14. Rear Wheel, Brake & Suspension

## Rear Wheel

### Detachment

Support the frame and lift the rear wheel.  
Remove the adjustment nut and detach the brake rod from the brake arm.  
Remove axle nut and detach the axle shaft.  
Detach the rear wheel.

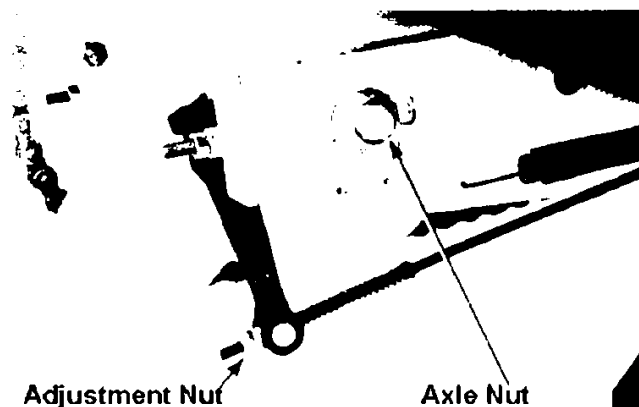

### Rear axle bend inspection

Place the axle on V-blocks and measure with a dial gauge.  
Take half the value indicated.  
 $\geq 0.2\text{mm} \rightarrow \text{Replace}$

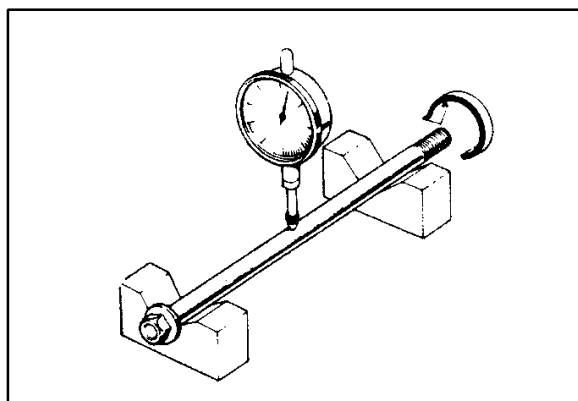

### Wheel rim inspection

Slowly turn the wheel and measure the deformation with a dial gauge.  
Radial direction  $\geq 2.0\text{mm}$  )  
Sideways  $\geq 2.0\text{mm}$  ) Replace

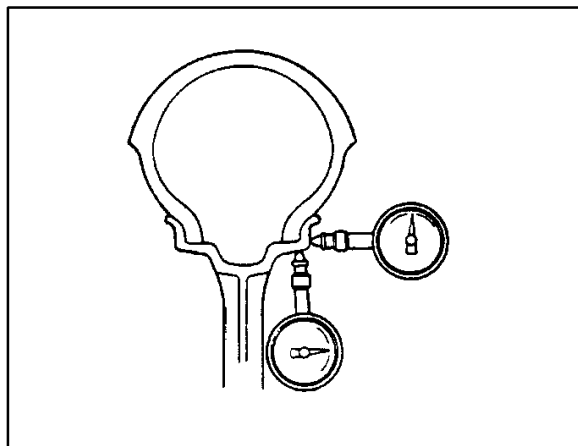

- A cast wheel cannot be adjusted.
- Replace with a new wheel if beyond limit.

### Wheel and flange bearing inspection

Rotate the inner race of the bearing with a finger and replace if there is loose fit or noisy.

Replace all three at the same time.

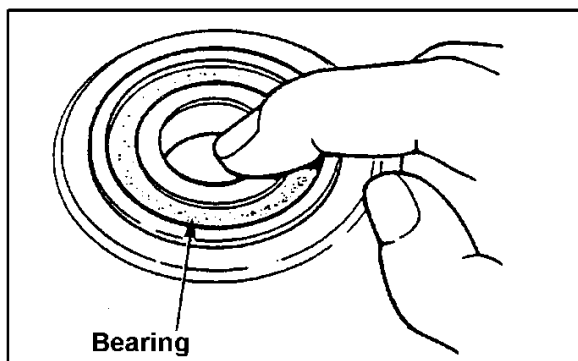

# CBR250R,RR 14. Rear Wheel, Brake & Suspension

## Final driven sprocket inspection

Inspect  $\geq$  final driven sprocket for wear / damage.

Inspect the drive chain and drive sprocket at the same time.

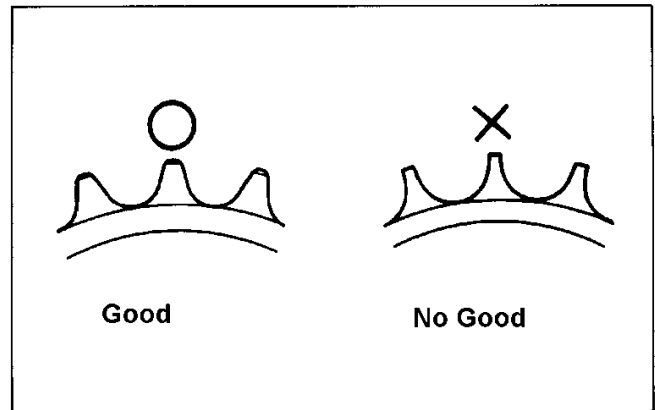

## Disassembly

Remove the side collar.  
Remove the dust seal.

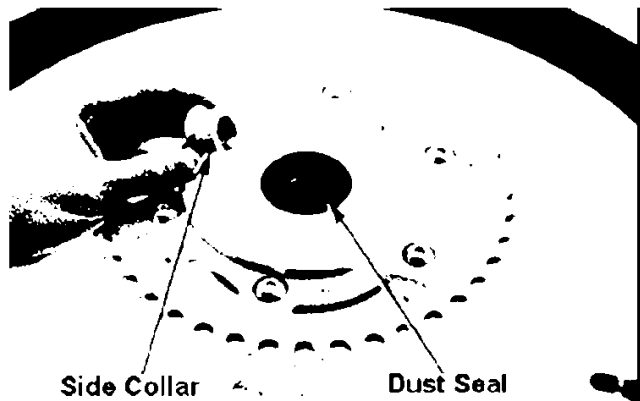

Remove the driven flange.

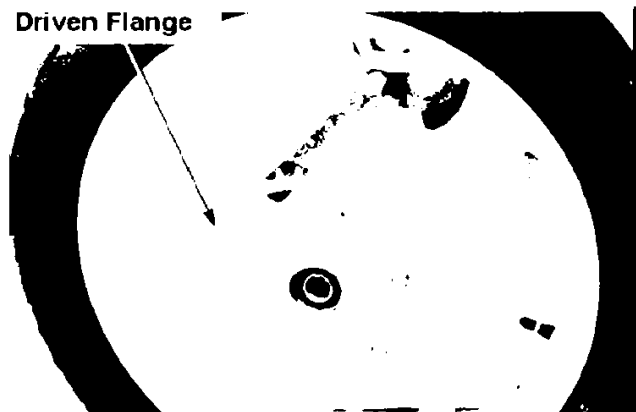

Remove the damper rubber.

Remove the O-Ring.

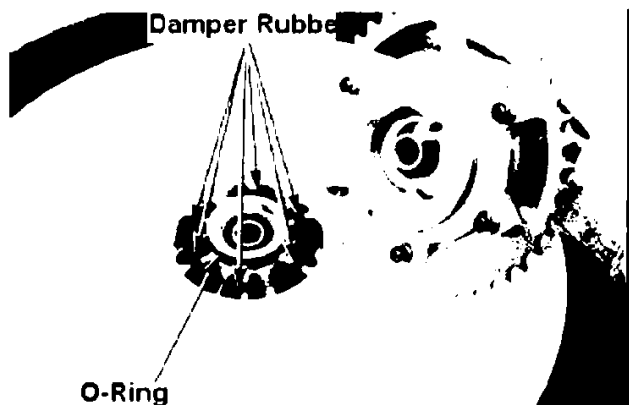

# CBR250R,RR 14. Rear Wheel, Brake & Suspension

Remove the collar and detach bearing.

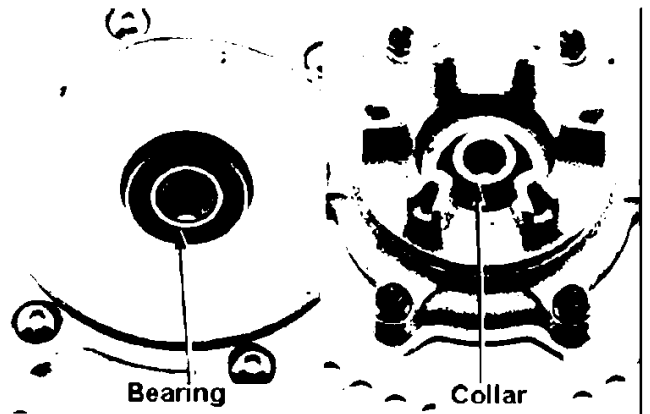

Remove the wheel bearing and distance collar.

Common tool

Bearing remover shaft  
07746-0050100

Bearing remover head (17mm)  
07746-0050500

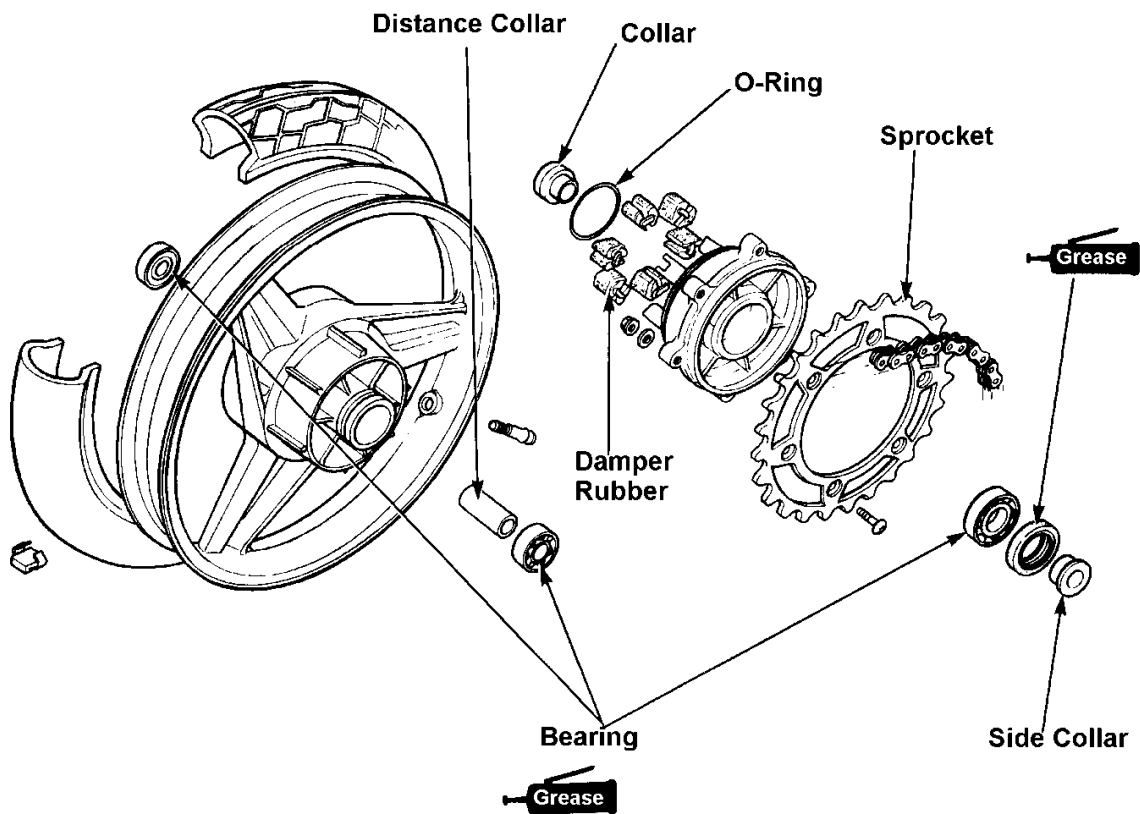
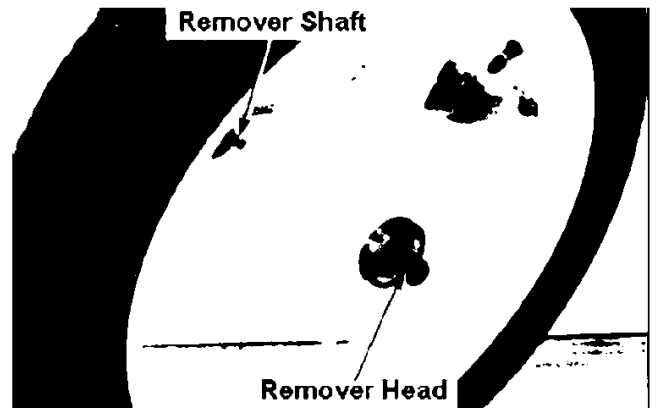

14-5

# CBR250R,RR 14. Rear Wheel, Brake & Suspension

Apply enough grease to the bearing.  
 Install the left bearing first.  
 Insert distance collar.  
 Install the right bearing.

- Install the bearings in parallel.
- Sealed side of the bearings should face outward.

### Common tools

Driver handle A	07749-0010000
Outer driver (37x40mm)	07746-0010200
Pilot (17mm)	07746-0040400

Place the bearing on a level surface and attach the collar.

Apply enough grease to the bearing.  
 Install the bearing to the driven flange.

Install firmly so that the bearing does not project.

### Common tools

Driver handle A	07749-0010000
Outer driver (42x47mm)	07746-0010300
Pilot (17mm)	07746-0040400

Inspect the damper rubber and the O-Ring for deformation, damage and wear.

Attach the O-Ring.

Attach the final driven sprocket.

If the driven sprocket nut was removed, attach the washer and apply oil to the nut, then tighten the nut.

**Torque: 2.8 ~ 3.4kg-m**

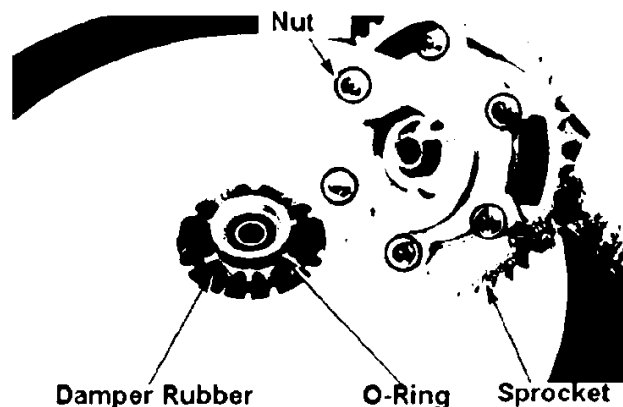
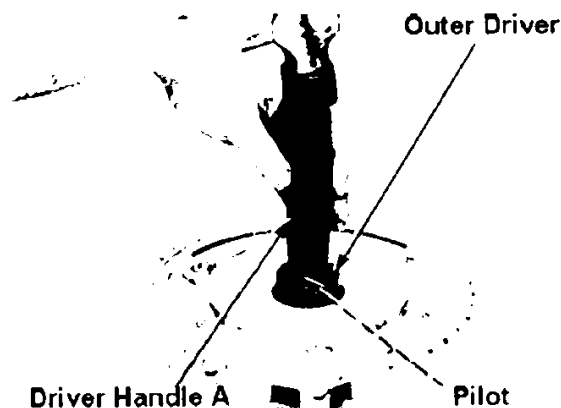
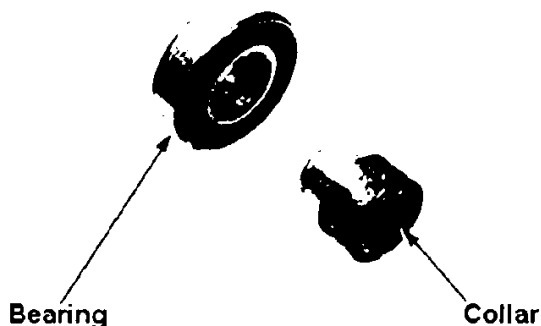
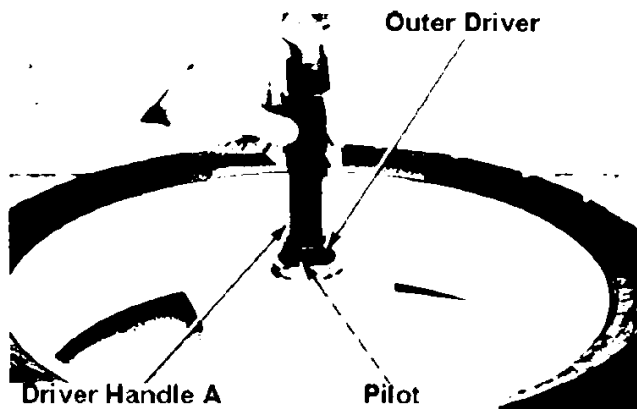

# CBR250R,RR 14. Rear Wheel, Brake & Suspension

Apply grease to the lip of the dust seal and attach it to the driven flange.

Attach the side collar.

## Attachment

Attach the brake panel to the rear wheel.  
Align the rear fork stopper with the slit on the brake panel.

Connect drive chain to the sprocket.

Attach the chain adjuster and fit the axle shaft from left side.

Tighten the axle nut:

**Torque: 8.0 ~ 10.0kg-m**

Adjust the drive chain (2-8)

## Rear Brake

### Inspection

Measure the inner diameter of the brake drum.

$\leq 141\text{mm}$  → Replace.

Measure the brake lining thickness.

$\leq 2.0\text{mm}$  → Replace

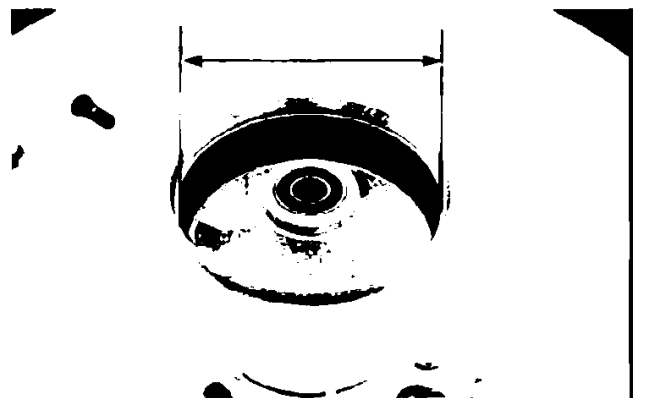
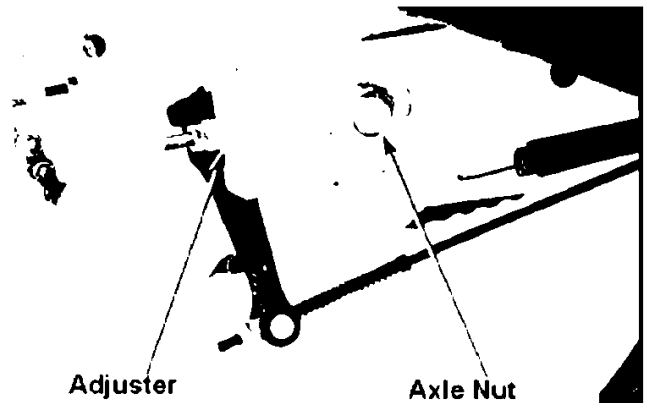
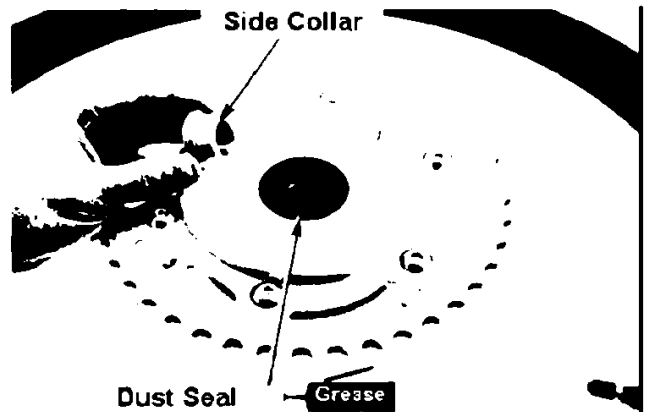

# CBR250R,RR 14. Rear Wheel, Brake & Suspension

## Disassembly

When re-using the brake shoes, mark on the side of the shoe so that the shoe can be re-fitted to the original place.

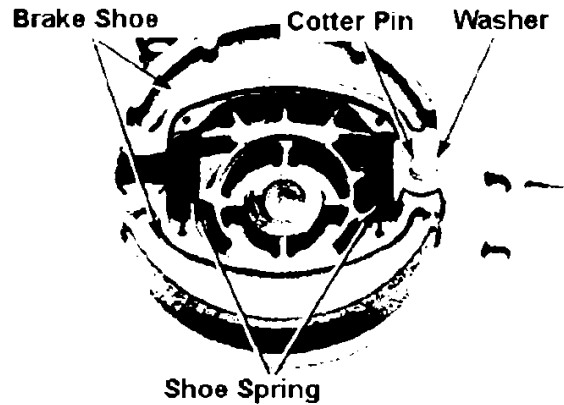

- Remove the cotter pin and the washer.
- Remove brake shoes from the brake panel by pushing them outwards.
- Detach shoe springs from the shoes.
- Remove the brake arm, wear indicator and the felt seal.
- Remove the brake cam.

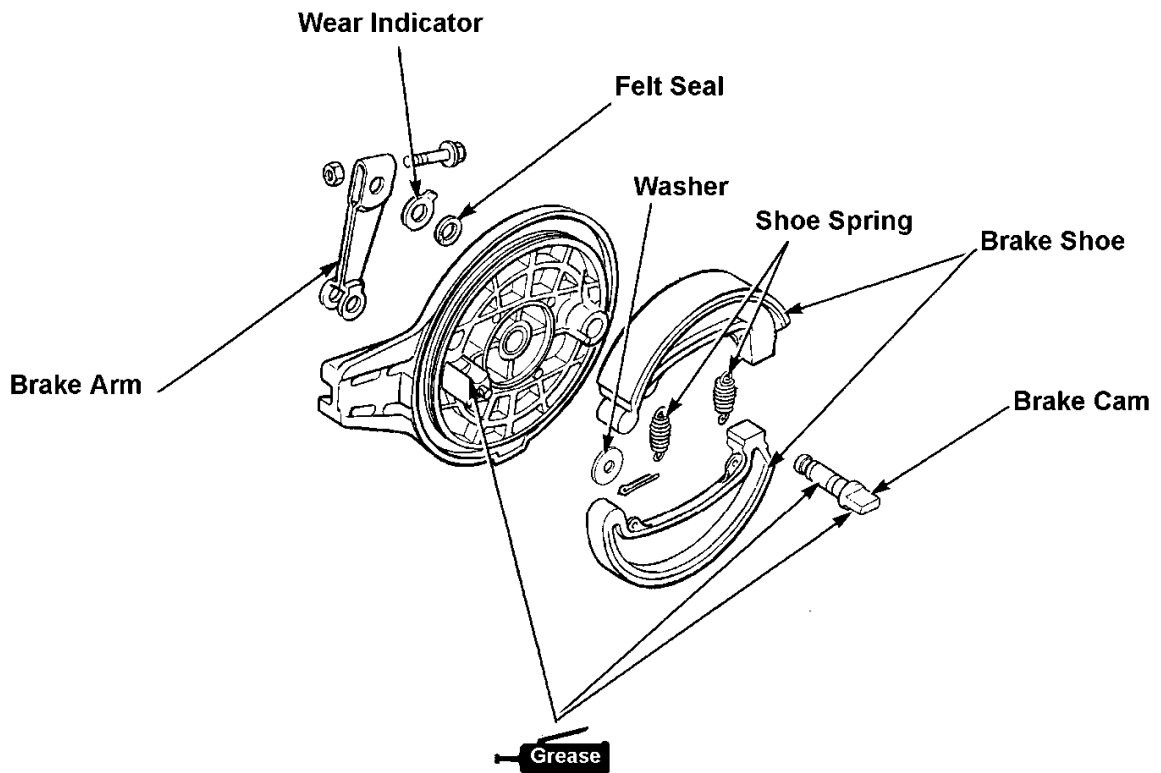

- Apply small amount of grease to the brake cam and anchor pin.
- Attach the brake cam.

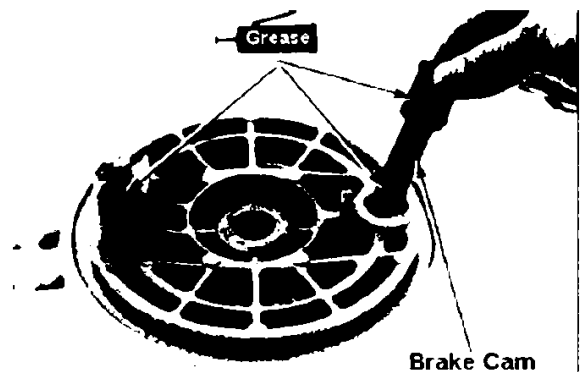



# CBR250R,RR 14. Rear Wheel, Brake & Suspension

Dip the felt seal in engine oil and attach to the brake panel.

Align the projection on the wear indicator and the slit on the brake cam, and attach the wear indicator to the brake cam.

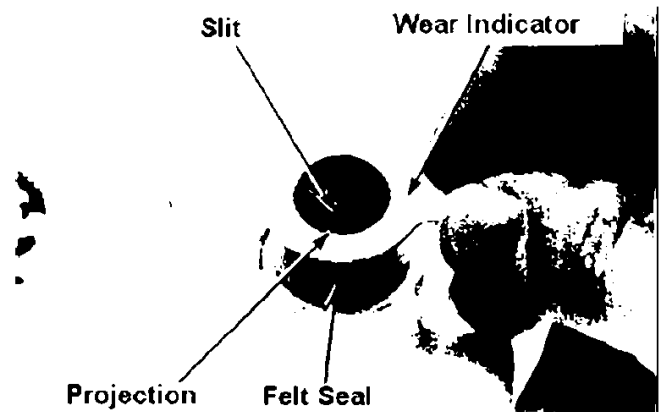

Attach the brake arm by aligning the punch marks.

Tighten the brake arm bolt.

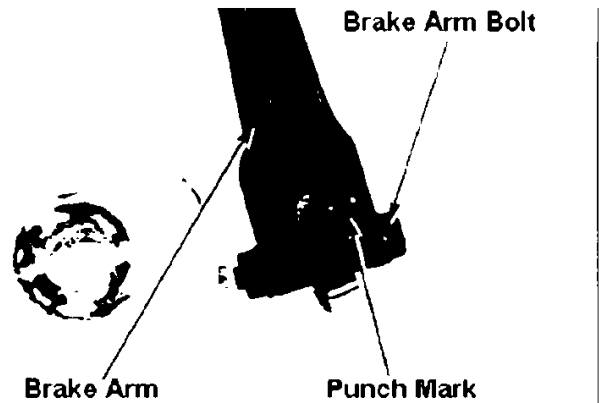

Install springs to the brake shoes.

Attach the shoes to the brake panel.

- When re-using the shoes, place them back to the original position by aligning the markings.
- Do not touch the brake lining to grease.
- Replace both shoes at the same time when replacing either of them.

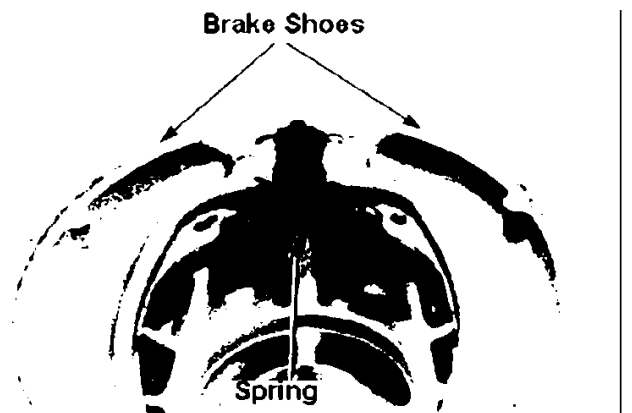

Attach the washer and the cotter pin.

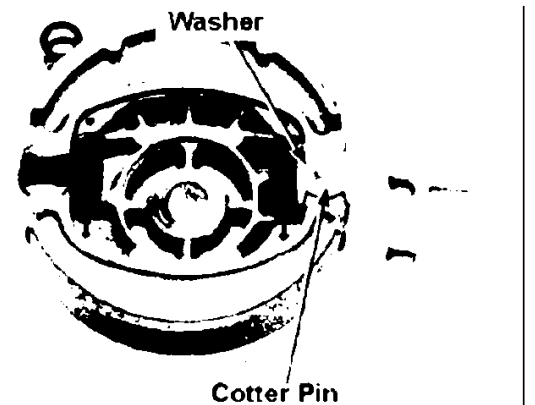

# CBR250R,RR 14. Rear Wheel, Brake & Suspension

## Brake Pedal

### Detachment

Remove the rear brake adjust nut (14-3).  
Remove the return spring.  
Remove two bolts and detach the right step.  
Detach the rear brake switch spring.  
Remove the circlip and detach the brake pedal.

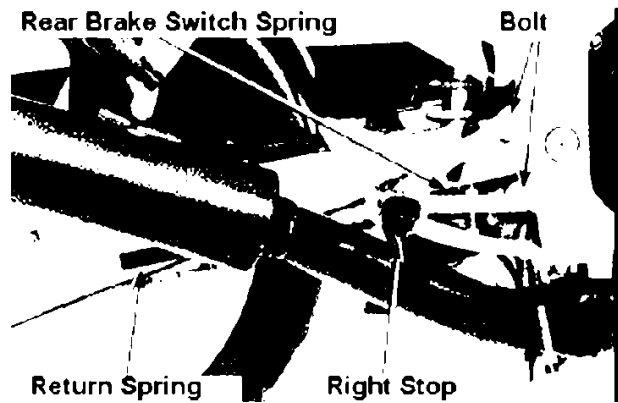

### Attachment

Apply grease on the pivot and attach the brake pedal to the right step pivot.

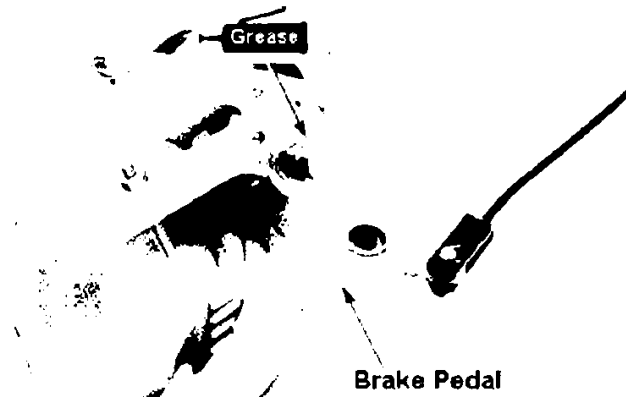

Finally, attach the circlip to the slit on the brake pedal pivot.

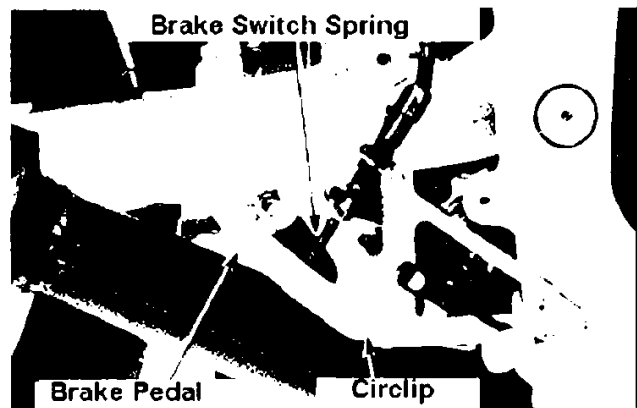

Attach the rear brake switch spring to the brake pedal.

Tighten the two bolts for the right step attachment.

**Torque: 2.5 ~ 3.0kg-m**

Attach the return spring to the rear brake rod.

Attach the rear brake, adjust nut and adjust the free movement of the brake pedal (2-5).

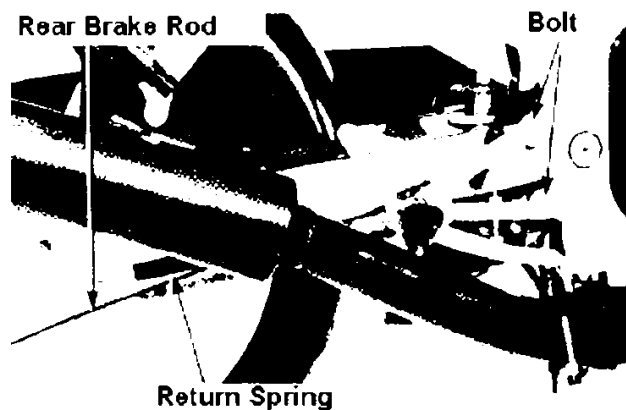

# CBR250R,RR 14. Rear Wheel, Brake & Suspension

## Rear cushion

### Detachment

Support the frame with the stand to lift the wheel.

Detach the left side cover.  
Remove the conrod bolt  
(cushion arm side).

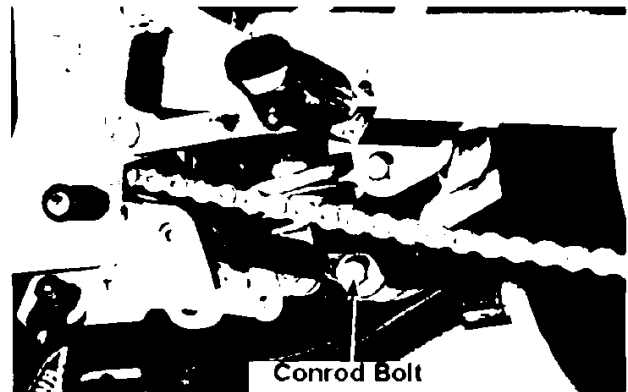

Remove the rear cushion lower bolt.

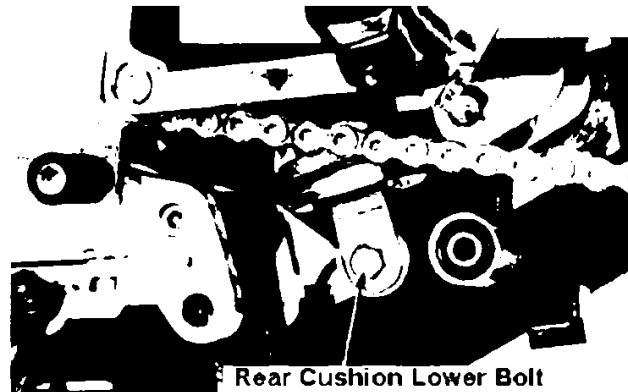

Remove the rear cushion upper bolt to detach the rear cushion.

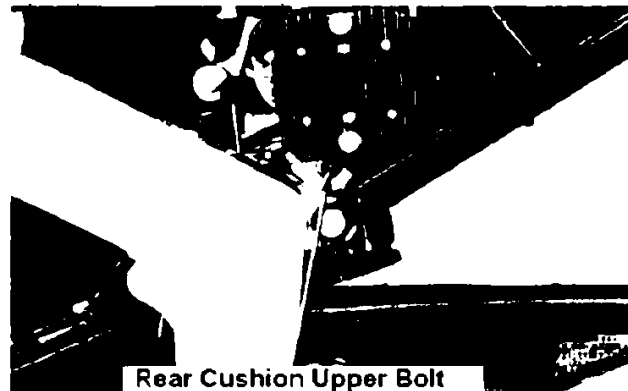

### Disassembly

Attach the rear cushion compressor

**Common tool**

Rear cushion compressor  
07959-3290001

**Exc. tool**

Rear cushion compressor attachment  
07959-MB10000

Compress the spring to the position so that a lock nut can be removed.

Loosen the lock nut and disconnect the lower joint.

Remove the compressor and remove the seat stopper, dust seal, spring guide, lower spring seat, spring, upper spring seat and the adjuster.

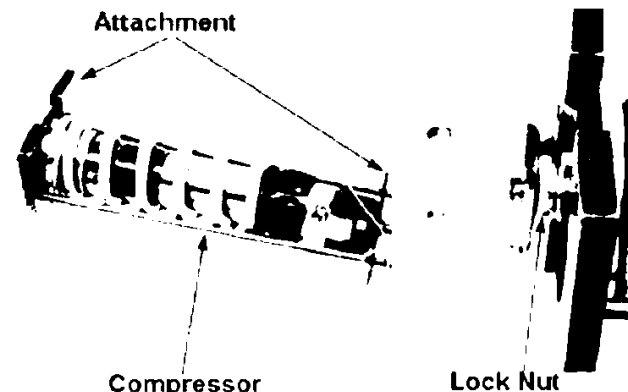

# CBR250R,RR 14. Rear Wheel, Brake & Suspension

## Inspection

Measure the relaxed length of the cushion spring.

$\leq 186.0\text{mm}$  → Replace

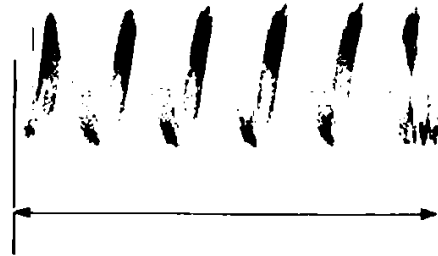

Inspect the rear damper for deformation, oil leak, bent rod and inspect the damper rubber for wear and damage.

Check smooth operation of the rear damper.

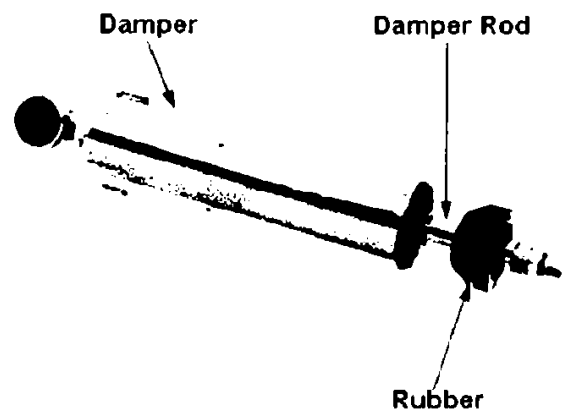

Fully stretch the rear damper and mark at 10mm from a damper edge.  
Place on a scale vertically and press the damper until the mark (use hydraulic power).

Scale : 12.3 ~ 16.0kg

Replace the damper if the compression is less than 9.8kg.

Inspect the adjuster, upper seat, lower seat, spring guide and the dust seal for wear, deformation, or damage.

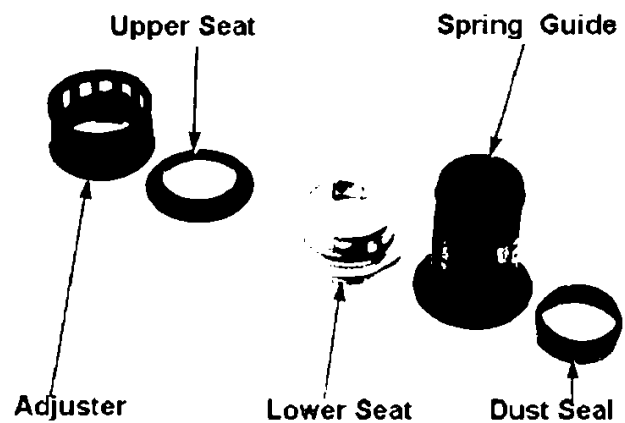
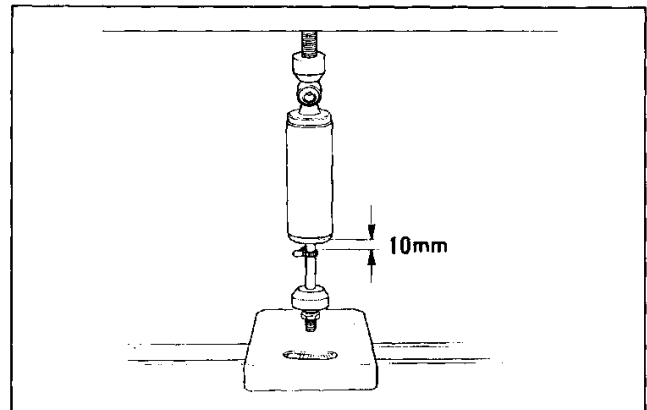

# CBR250R,RR 14. Rear Wheel, Brake & Suspension

## • Assembly

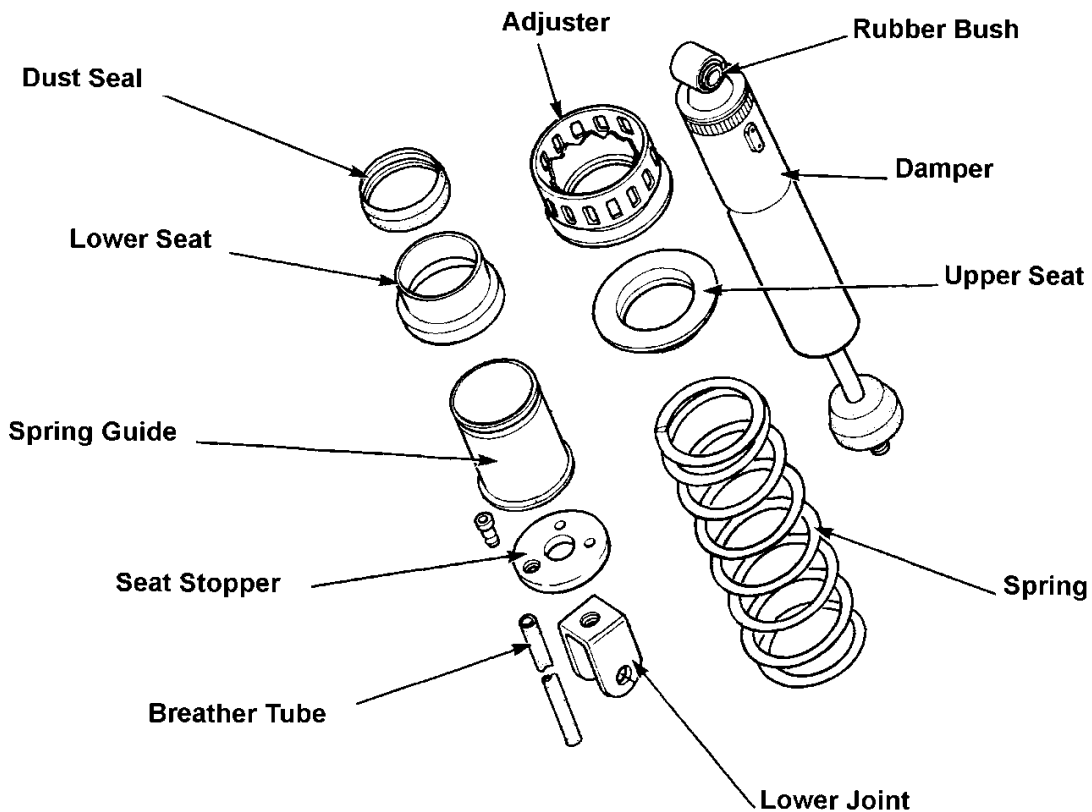

### Draining gas from a damper unit

#### Please strictly follow the instructions

##### CAUTION

- Never heat or disassemble the unit or it may explode.
- When disposing the damper unit, drain gas by following the procedure below.

- When the hole is opened, debris will spurt out. Wear safety goggles.
- Do not drill anywhere else.

Disassemble the rear cushion (14-11)  
Determine the position of the drill by using a hole puncher to the position shown in the figure. Wrap the damper unit with a plastic bag and fix it to a vice in standing position. By using the cooling air of the drill, inflate the bag in order to avoid the drill catching the bag. Release air as required. Drill a 3mm-diameter hole on the position marked with a punch to drain gas.

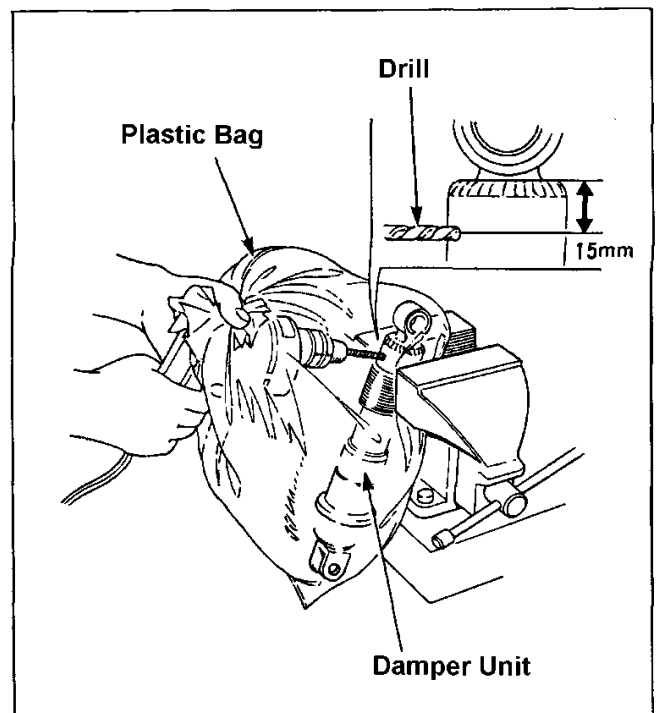

## CBR250R,RR 14. Rear Wheel, Brake & Suspension

Attach the adjuster, upper seat, spring, lower seat, dust seal, spring guide and the seat stopper to the damper.

Compress the spring until the lower joint can be attached by using the rear cushion compressor.

### Common tool

Rear cushion compressor

07959-3290001

Rear cushion compressor attachment

07959-MB10000

Attach the lower joint so as to have the end of the damper rod thread 10mm from the inner edge surface of the lower joint.

Spring attachment length: 173.8mm

Fix the lower joint and tighten the lock nut.

**Torque: 3.8 ~ 6.0kg-m**

Apply screw locking liquid to the thread of the damper rod.

Firmly attach the breather tube to the lower joint.

### Bush inspection

Inspect an upper joint collar and the rubber bush for wear and damage.

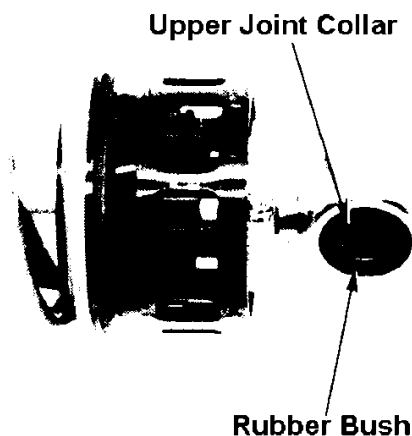
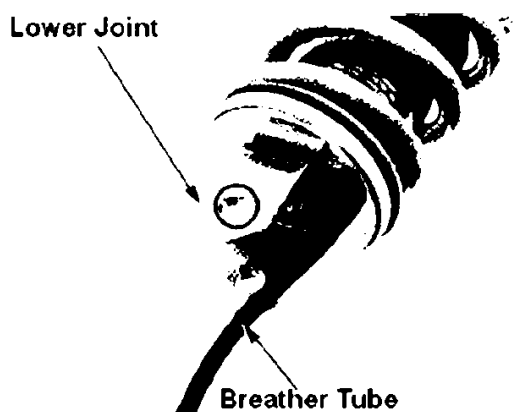
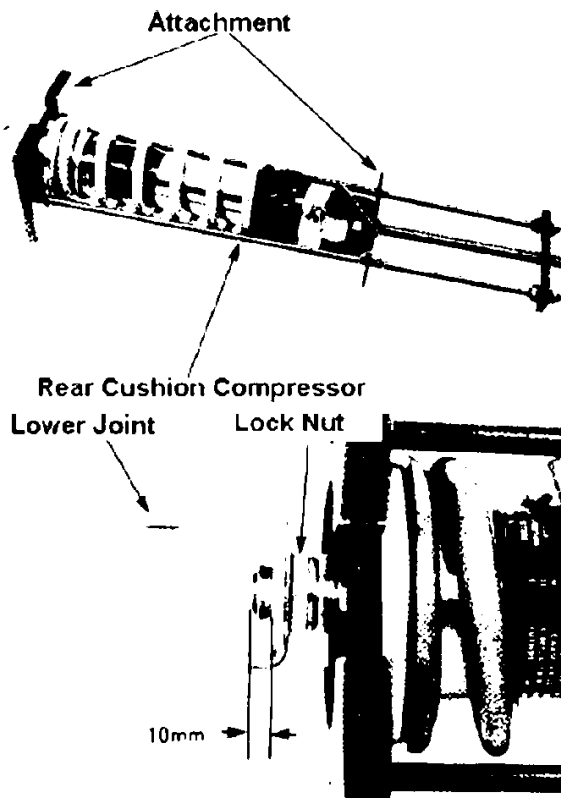

# CBR250R,RR 14. Rear Wheel, Brake & Suspension

## Attachment

Insert the rear cushion from underneath and tighten the rear cushion upper bolt.

**Torque: 5.0 ~ 6.0kg-m**

Tighten the rear cushion lower bolt.

**Torque: 5.0 ~ 6.0kg-m**

Attach the cushion so as to have the breather tube facing the front.

Tighten the conrod bolt (cushion arm side).

**Torque: 5.0 ~ 6.0kg-m**

## Suspension linkage

### Detachment

Remove the conrod bolt (frame and cushion side) and detach the cushion conrod.  
Remove the rear cushion lower bolt and a cushion arm bolt and detach the cushion arm.

### Disassembly / inspection

Detach the seal collar from the cushion arm and inspect the collar for wear, damage and deformation.

Replace needle bearings for the cushion arms if any loose or damage was found.  
Detach dust seals from the cushion conrod and inspect them for wear, damage and deformation.

Replace needle bearings if loose fit or damage was found.

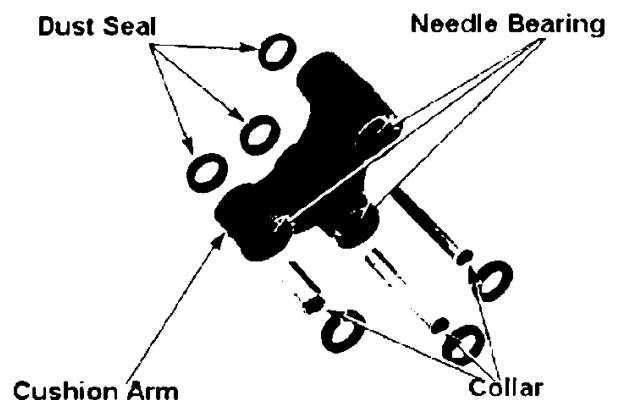
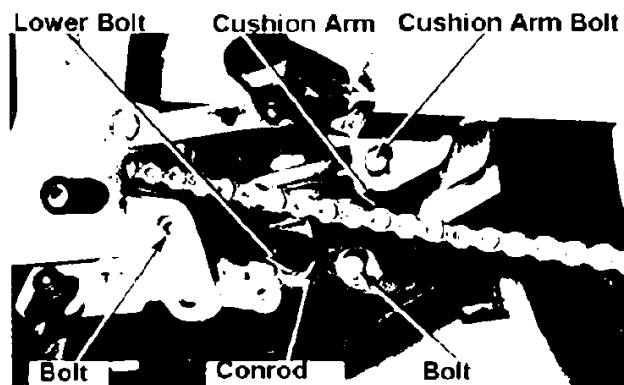
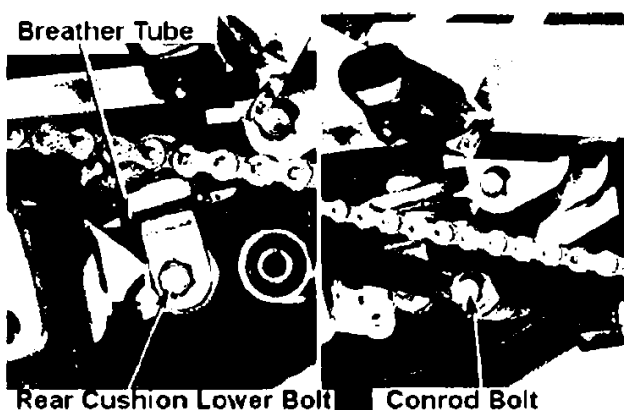
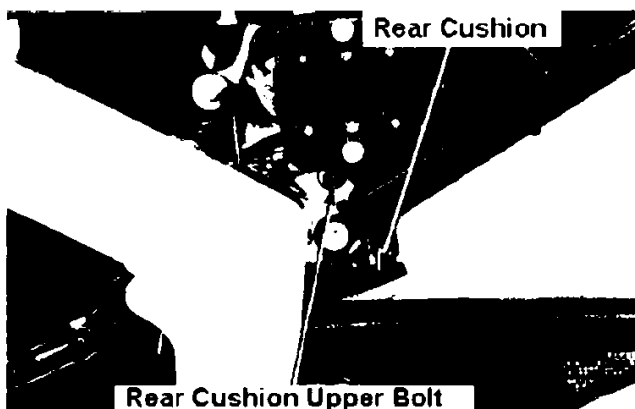

# CBR250R,RR 14. Rear Wheel, Brake & Suspension

Detach dust seals from the cushion conrod and inspect them for wear, damage and deformation.

Replace needle bearings if loose fit or damage was found.

## Needle bearing replacement

Remove the cushion arm needle bearing.

Exc. tools

Bearing remover	07936-3710300
Remover handle	07936-3710100
Remover sliding weight	07741-0010201

Detach the cushion conrod needle bearing

Exc. tools

Bearing remover	07936-3710300
Remover handle	07936-3710100
Remover sliding weight	07741-0010201

Apply grease to the cushion arm needle bearing.

By using a hydraulic compressor, attach the needle bearing to the cushion arm.

Common tools

Driver handle A	07749-0010000
Outer driver (24x36mm)	07746-0010700
Pilot (17mm)	07746-0040400

- Press the marked surface in.

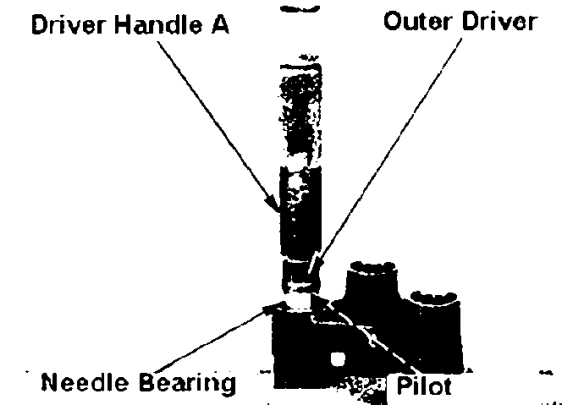
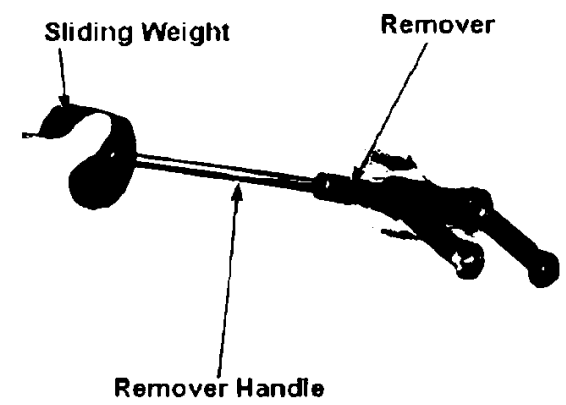
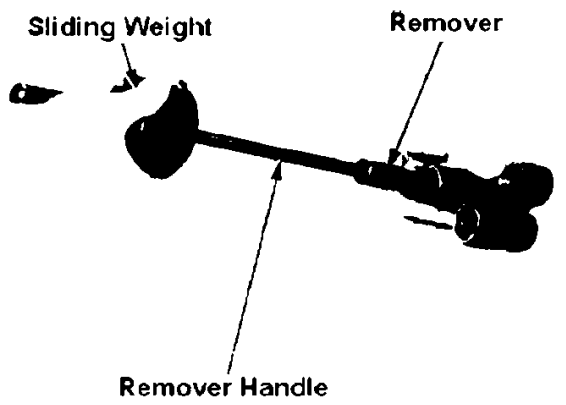
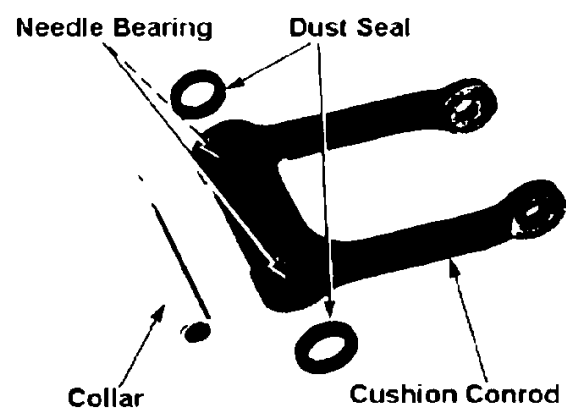



# CBR250R,RR 14. Rear Wheel, Brake & Suspension

Apply grease to the cushion conrod needle bearing.

By using a hydraulic press, attach the needle bearing to the cushion arm.

**Common tools**

Driver handle A	07749-0010000
Outer driver (24x26mm)	07746-0010700
Pilot (17mm)	07746-0040400

Press the marked side in.

**Assembly**

Apply grease to collars, lips of dust seals and needle bearings and attach to the cushion arm.

Apply grease to the collar, lips of dust seals and bearings and attach to the cushion conrod.

**Attachment**

Attach the cushion arm and the cushion conrod.

**Torque:**

Cushion arm bolt	5.0 ~ 6.0kg-m
Rear cushion lower bolt	5.0 ~ 6.0kg-m
Conrod bolt (frame side)	5.0 ~ 6.0kg-m

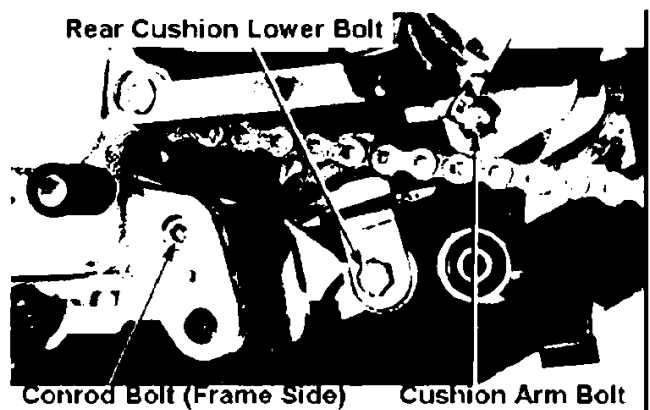
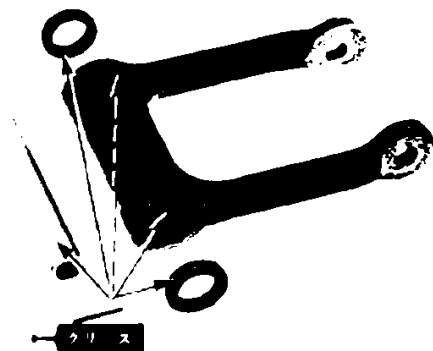
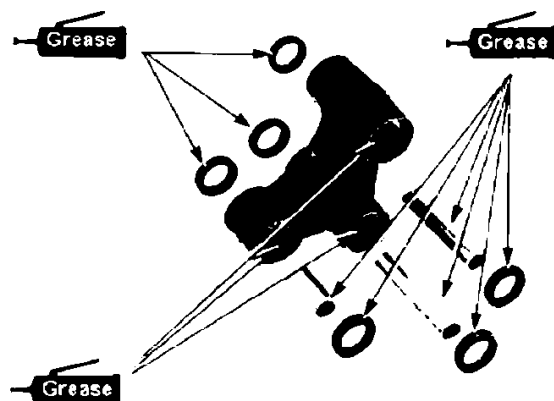
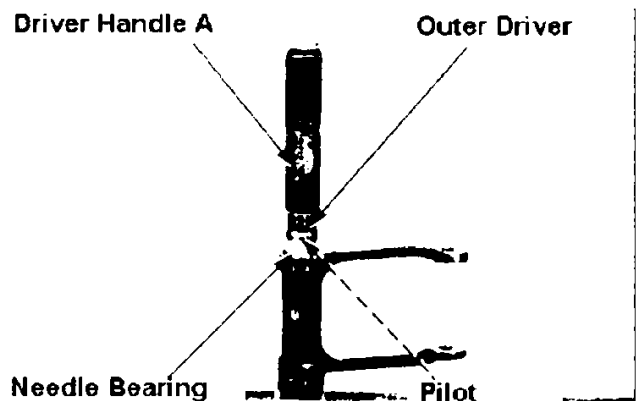

# CBR250R,RR 14. Rear Wheel, Brake & Suspension

Tighten the conrod attachment bolt.  
Torque: 5.0 ~ 6.0kg-m

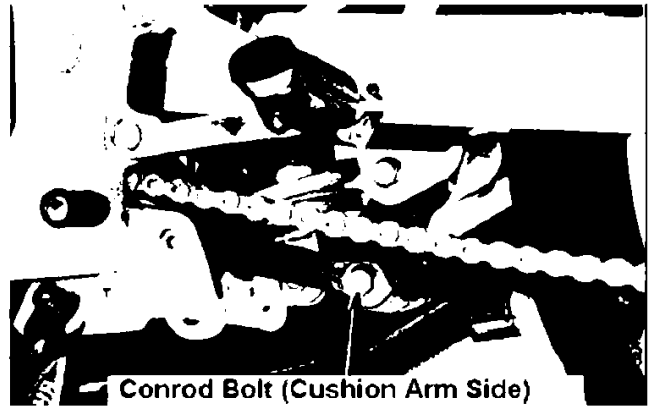

## Rear fork

### Detachment

Detach the rear wheel (14-3)

Detach the rear fender (16-2)

Detach the rear brake return spring from the rear fork.

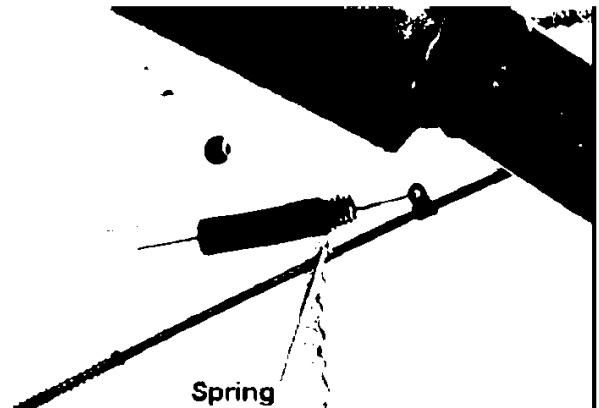

Remove the conrod bolt (cushion arm side)

Remove the cushion lower bolt and the cushion arm bolt and detach the cushion arm.

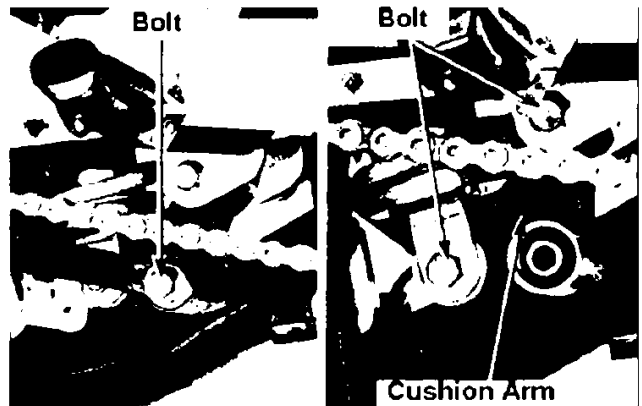

Remove the rear fork pivot nut.

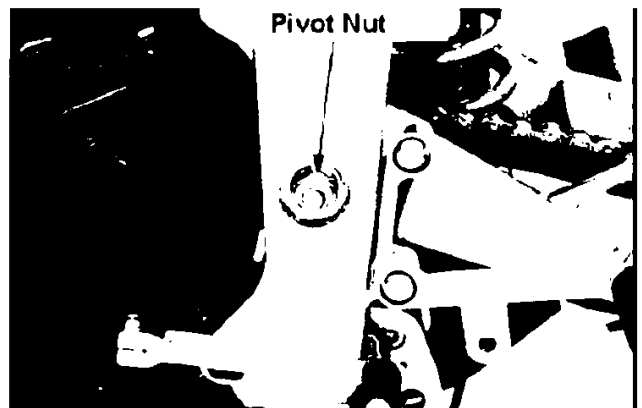

# CBR250R,RR 14. Rear Wheel, Brake & Suspension

Remove the rear fork pivot lock nut.

Exc. tool

Lock nut wrench  
07GMA-KT70200

Remove the rear fork pivot adjust bolt and the pivot bolt at the same time.  
Detach the rear fork.

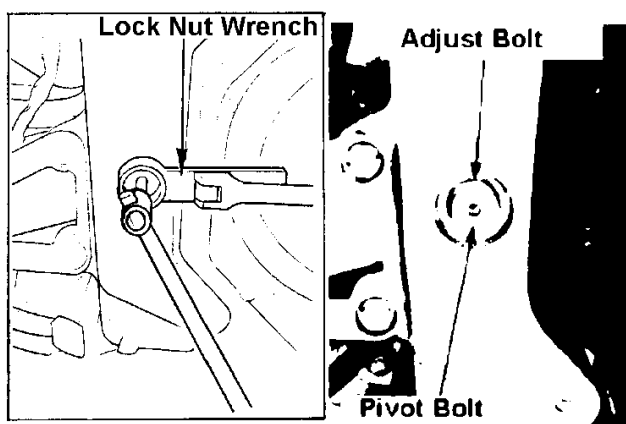

## Disassembly

Detach the chain slider and the left pivot collar from the rear fork.

Inspect the pivot collar for damage.

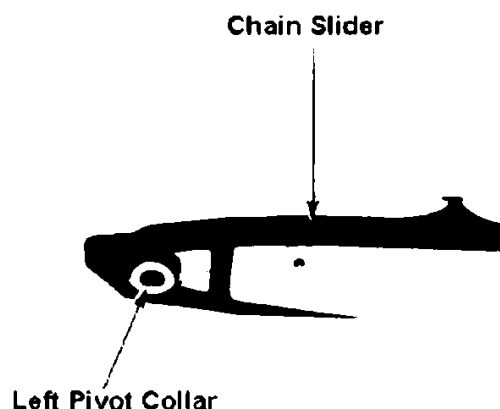

Detach the dust seal.

Detach the distance collar.

Inspect the dust seal and the distance collar for damage.

Inspect needle bearing for damage.

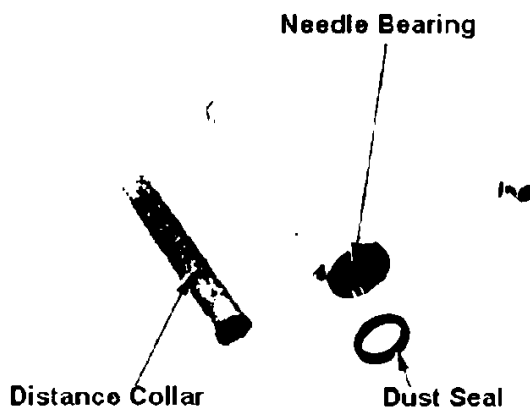

Detach the right pivot collar.

Detach the dust seal.

Inspect the pivot collar and the dust seal for damage.

Inspect the ballbearing for loose fit, sand and smooth spin.

Remove the circlip when replacing the bearing.

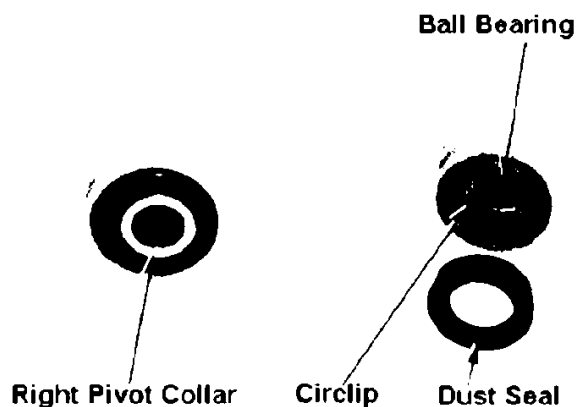

# CBR250R,RR 14. Rear Wheel, Brake & Suspension

## Bearing Replacement

Detach the right pivot bearing (ball bearing).

Exc. tool

Driver shaft 07946-MJ00100

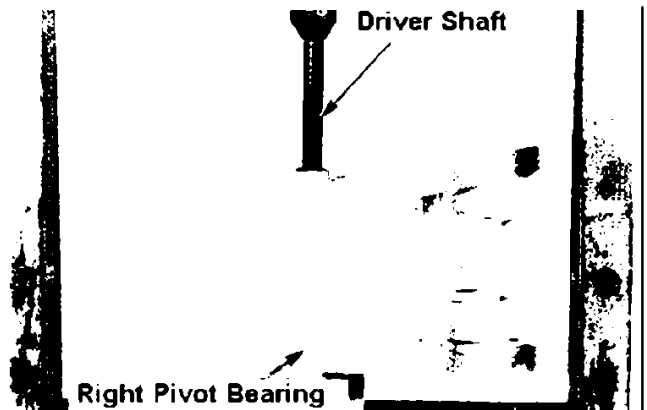

Set the exclusive tool to the left pivot bearing (needle bearing).

Exc. tool

Needle bearing remover 07GMD-KT70200

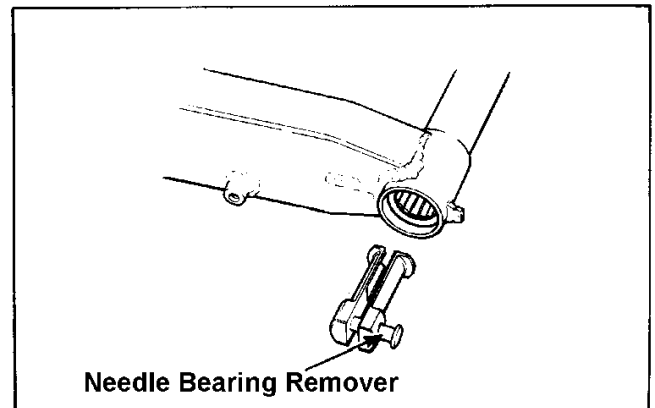

Set the driver shaft as shown in the figure.  
Detach the left pivot bearing.

Exc. tools

Driver shaft 07946-MJ00100  
Needle bearing remover 07GMD-KT70200

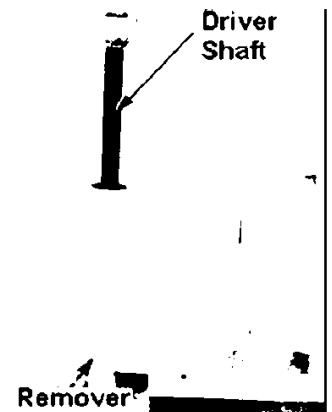
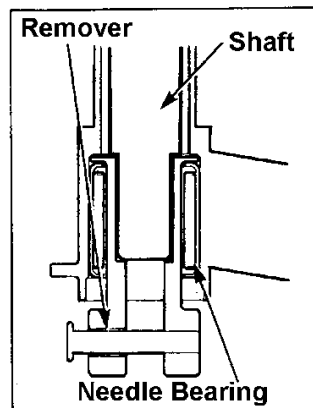

By using a hydraulic press, set the left pivot bearing (needle bearing).

Exc. tool

Outer driver (28x30mm) 07946-1870100

Common tool

Pilot (22mm) 07746-0041000  
Driver handle A 07749-0010000

Press the marked side in.

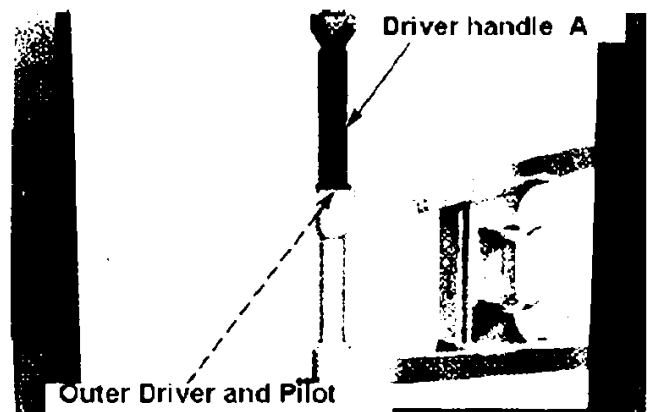

# CBR250R,RR 14. Rear Wheel, Brake & Suspension

By using hydraulic press, insert the right pivot bearing (ball bearing).

### Common tool

- Outer driver (32 x 35mm) 07746-0010100
- Pilot (15mm) 07746-0040300
- Driver handle A 07749-0010000

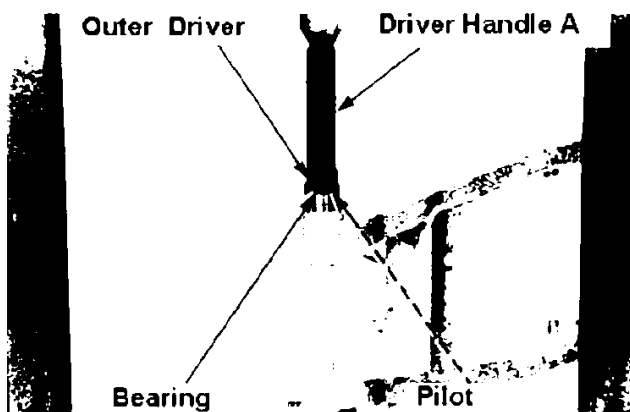

### Assembly

Attach the circlip to the slit.

Apply grease to the lip of the right pivot dust seal and attach the seal.

Attach the right pivot collar.

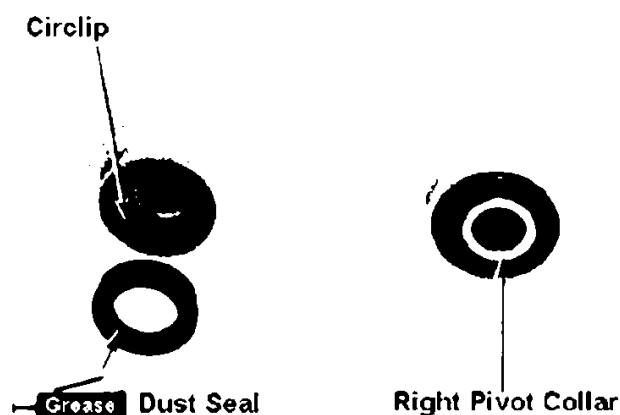

Apply enough grease to the left pivot bearing.

Attach the distance collar.

Apply grease to the lip of the left pivot dust seal and attach the dust seal.

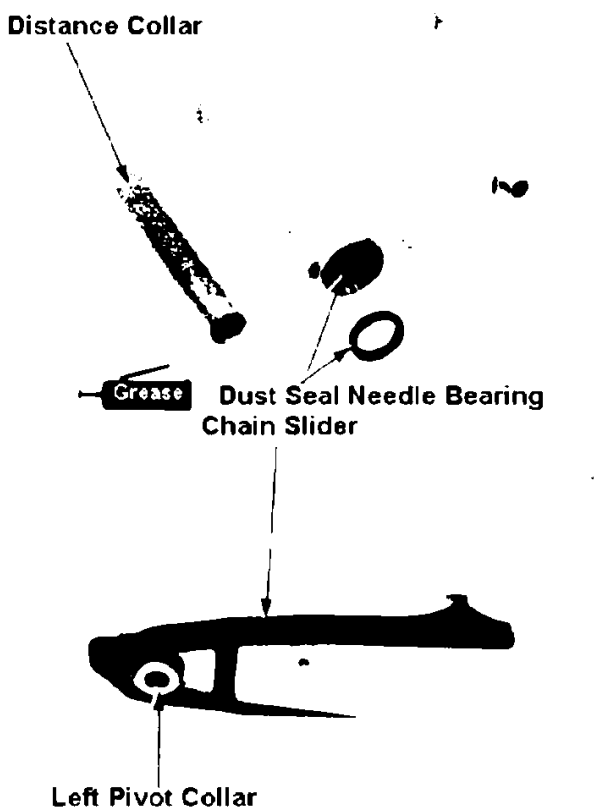

Attach the left pivot collar.

Attach the chain slider.

# CBR250R,RR 14. Rear Wheel, Brake & Suspension

## Attachment

Screw in the rear fork pivot adjust bolt and stop before it's edge goes beyond the inner surface of the frame.

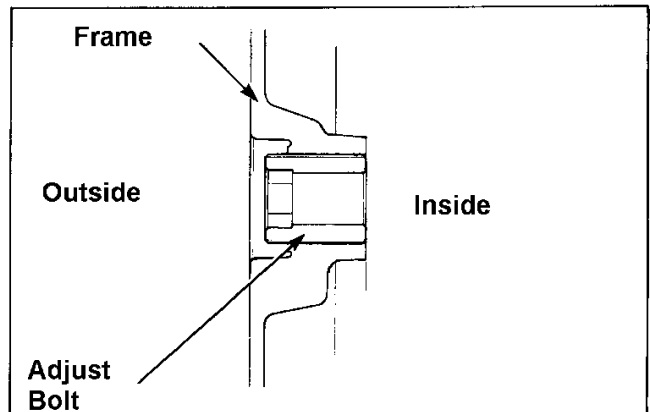

Attach the rear fork and insert the pivot bolt from an adjust bolt side and align the hexagon part.

Rotate the pivot bolt and tighten the adjust bolt.

**Torque: 1.0 ~ 2.0kg-m**

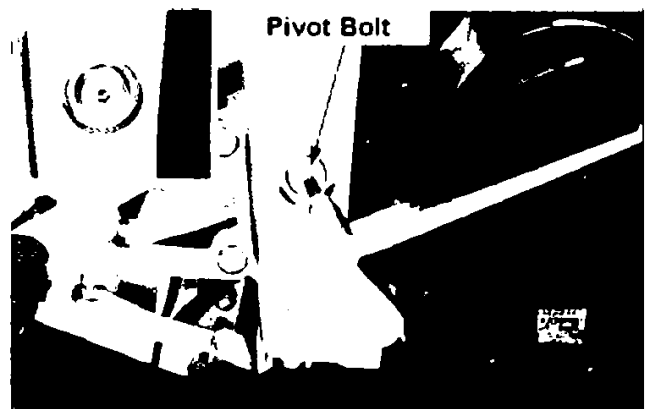

Attach the lock nut and tighten.

Exc. tool

Lock nut wrench  
07GMA-KT70200

When tightening the lock nut, hold the pivot bolt in order to prevent an adjust bolt from spinning together.

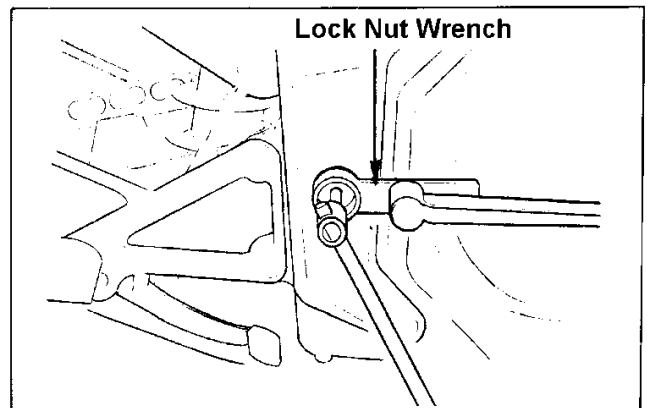

**Torque: 6.0 ~ 7.0kg-m**

Attach and tighten the pivot nut.

**Torque: 6.0 ~ 7.0kg-m**

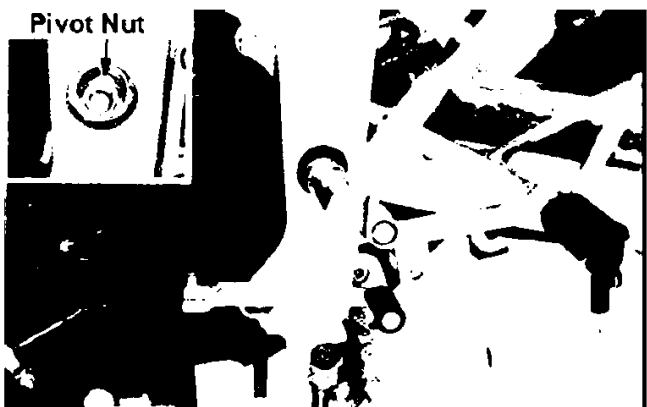

# CBR250R,RR 14. Rear Wheel, Brake & Suspension

---

Attach the cushion arm and tighten the bolt.

**Torque:**

Cushion arm bolt	5.0 ~ 6.0kg-m
Rear cushion lower bolt	5.0 ~ 6.0kg-m
Conrod bolt (cushion arm side)	5.0 ~ 6.0kg-m

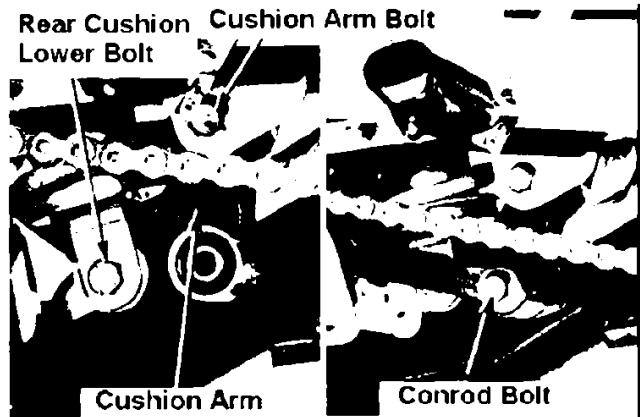

Attach the rear brake return spring to the rear fork.

Attach the rear fender chain guard (16-2)

Attach the rear wheel (14-7)

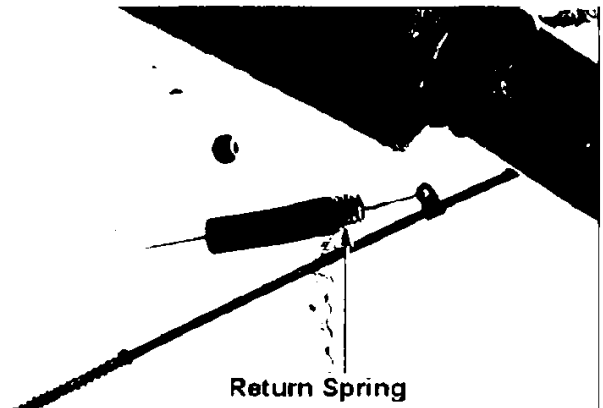

• Disassembly

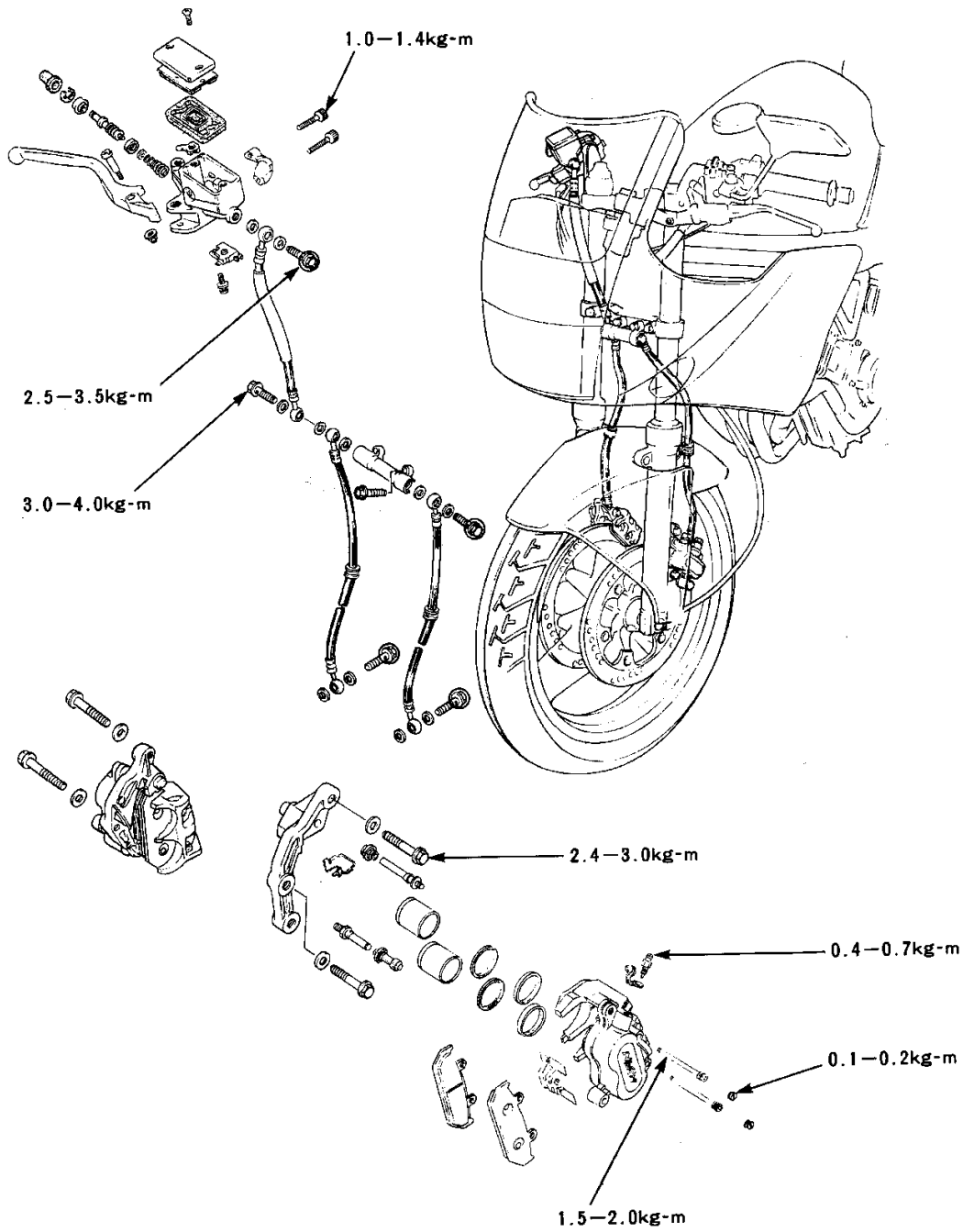



Disassembly	15-0	Brake pad / disk	15-4
Service information	15-1	Master cylinder	15-6
Troubleshooting	15-2	Brake caliper	15-9
Brake fluid replacement / air bleed	15-3		

**Service information**

**General caution**

- When replacing brake fluid, keep away from debris and water.
- In order to avoid chemical reaction, do not mix different brands of brake fluids.
- Do not re-use the drained brake fluid.
- Keep the fluid away from other parts as the brake fluid will damage the paint, plastic or rubber surfaces.
- Split brake fluid should be wiped off with a cloth.
- Cover the joint on hoses to prevent brake fluid leaks.
- Clean the detached parts with brake fluid and check air passages with compressed air.
- Keep the detached parts away from dust or debris.
- Re-assemble the parts after checking they have no dust or debris attached.
- Do replace all of the designated parts.
- Brake pads can be replaced without disconnecting hoses.
- Bleed air from the system after disconnecting the brake hose.

**Service standards**

Item	Standard	Limit
Brake disk thickness	3.8-4.2	3.5
Brake disk deformation	-	0.3
Master cylinder inner diameter	14.000-14.043	14.055
Master piston outer diameter	13.957-13.984	13.945
Caliper cylinder inner diameter	27.000-27.050	27.06
Caliper piston outer diameter	26.918-26.968	26.91

**Torque**

Front caliper bracket	2.4~3.0kg-m	Brake hose attachment Bolt	2.5~3.5kg-m
Hanger pin	1.5~2.0kg-m	Brake hose tightening Bolt	3.0~4.0kg-m
Master cylinder Holder bolt	1.0~1.4kg-m	Bleeder valve	04~0.7kg-m
Hanger pin plug	0.1~0.2kg-m		

**Tools**

**Exclusive tool**

Snap ring pliers      07914-3230001

**Troubleshooting****Poor brake performance**

- Air in brake system
- Lack of brake fluid
- Brake fluid leak
- Brake pad wear
- Dirty pad / disk surface

**Brake lever heavy or unable to release**

- Caliper piston fixed
- Brake system jammed
- Master piston jammed

**Noise from brake**

- Pad dirty / worn out
- Disk deflection / wear / dirt
- Poor caliper attachment
- Misalignment of the disk or the wheel
- Lack of lubrication at hanger pin – pad contact

**Brake fluid replacement / air bleed**

Place the master cylinder horizontally and check the brake fluid level.

- Watch out for debris/water when refilling the brake fluid.
- Do not mix different brands of brake fluids, it may cause change in quality.
- Keep the brake fluid away from painted, plastic and rubber surfaces.
- Use DOT3 or DOT4 brake fluid.

**Brake fluid bleed**

Remove the reservoir cap and the diaphragm. Attach the transparent tube to the bleeder valve. Loosen the bleeder valve on the caliper and pump the brake lever. Repeat this until brake fluid stops coming out from the valve.

- Keep brake disks and pads clean or the braking performance may drop.
- If the pads are dirty, replace them, wipe dirt off from brake disks.

**Air bleed**

Keep monitoring the brake fluid level. If the level comes down to the minimum level, refill the fluid and resume the work.

Tighten the bleeder valve and refill the brake fluid in the master cylinder to the maximum level.

Attach the diaphragm. Manipulate the brake lever and bleed air from the separator. Repeat this until no more air comes out from the separator and the primary port (feel heavy on the lever). Refill the fluid in the master cylinder to the maximum level.

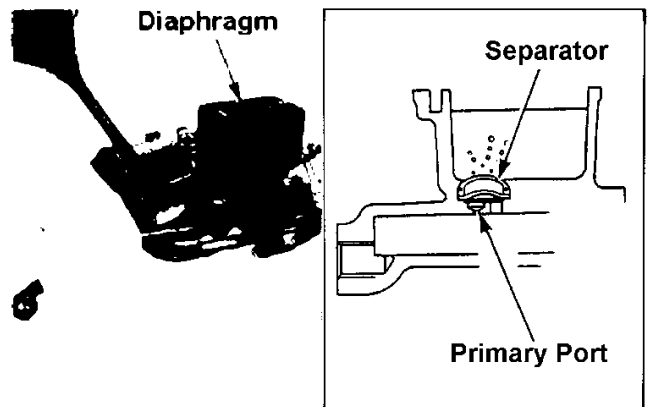
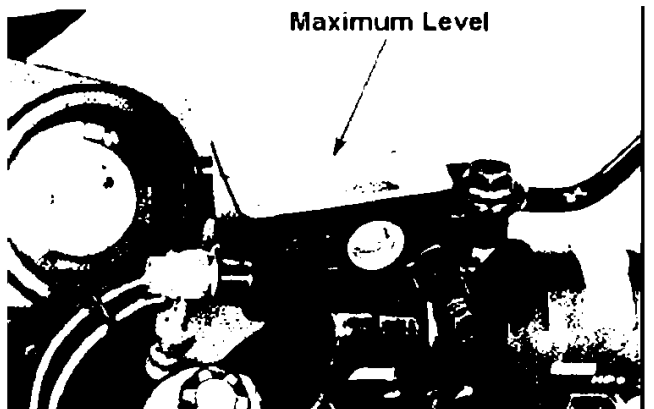
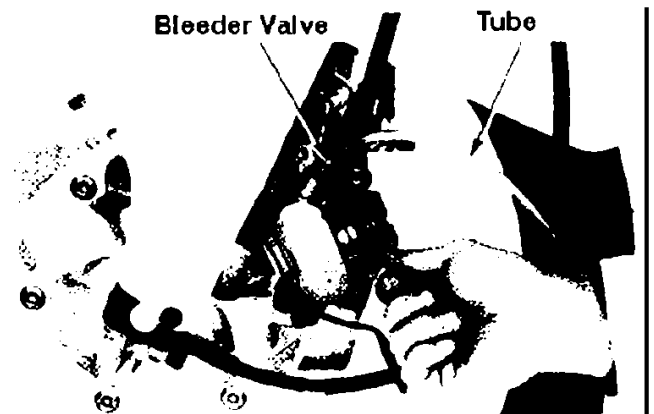

Attach a transparent tube to the bleeder valve on the caliper, and place a container underneath.

1. Pump the brake lever several times and loosen the bleeder valve for ½ turn while holding the lever, then tighten the valve.

- Do not release the brake lever until the bleeder valve is tightened.

2. Slowly release the brake lever. Leave it for a few seconds in loose position.

Repeat 1) and 2) until no more air comes out from the bleeder valve.

Refill the brake fluid to the maximum level.

Tighten the bleeder valve

Torque: 0.4 ~ 0.7kg-m

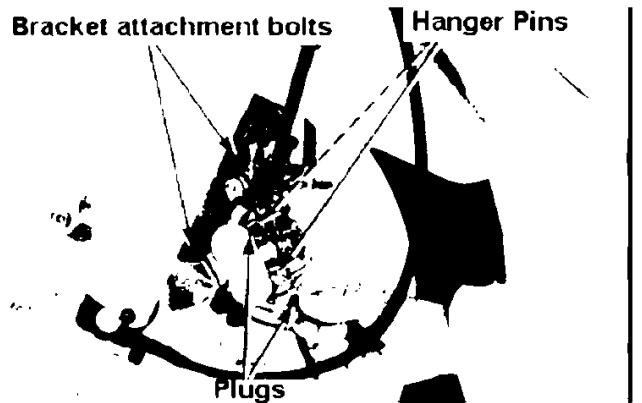
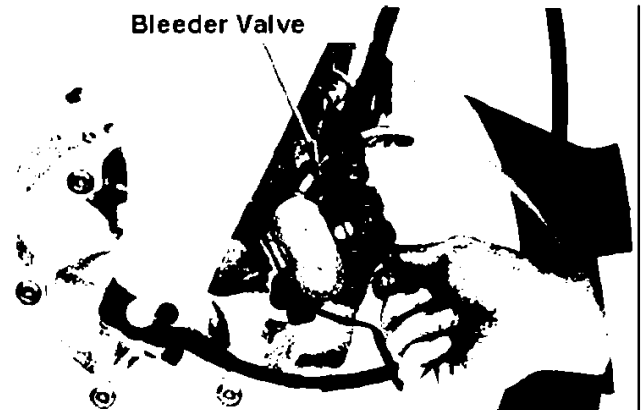

**Brake Pad / Disk**

**Brake pad replacement**

Do not disconnect brake hose when replacing the pads.

Disconnect plugs and loosen hanger pins. Remove two bracket attachment bolts and disconnect the caliper bracket from the front fork.



Push the caliper piston in so as to fit the new pad.

Pull hanger pins out and detach the pads.

No need to detach the caliper bracket when replacing the pads.

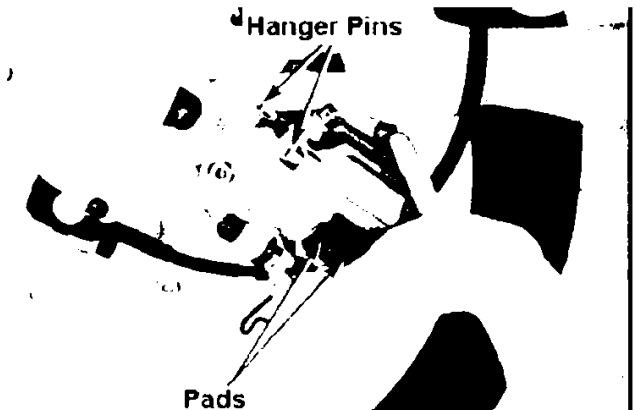

Check the positions of the pad spring and the shim.

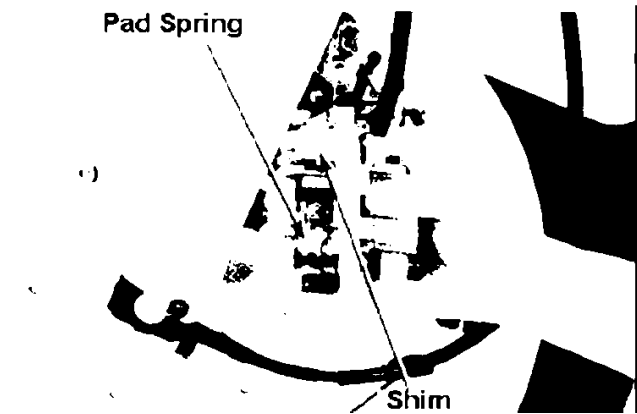

Apply silicone grease to the pin on the caliper bracket.

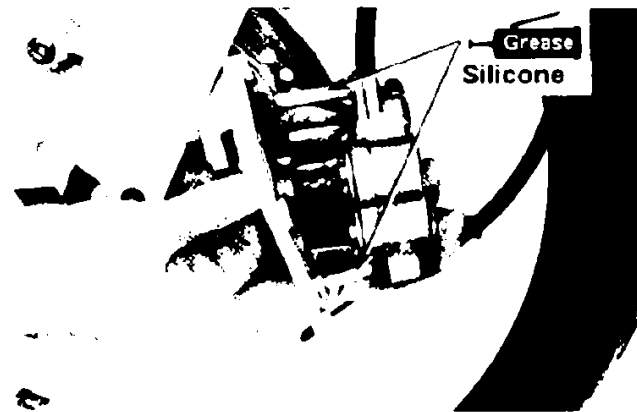

Attach new pads to the caliper.

Replace both pads at the same time.

Press the pads in. Align the pin holes on the pads and lightly tighten the hanger pins.

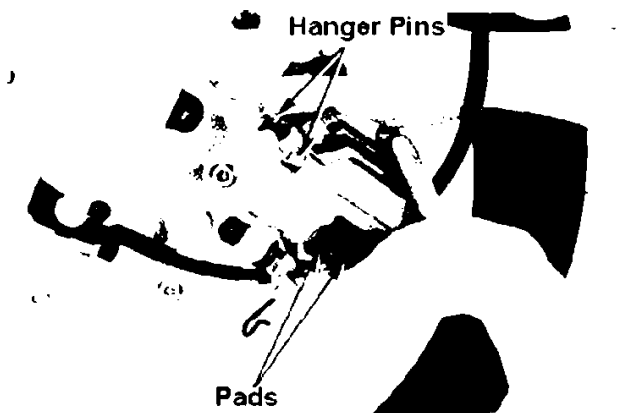

Attach the caliper to the front fork.

Tighten the bracket attachment bolt.  
Torque: 2.4 ~ 3.0kg-m

Tighten the hanger pins.  
Torque: 1.5 ~ 2.0kg-m

Attach plugs  
Torque: 0.1 ~ 0.2kg-m

After replacing the pads, pump the brake lever to press the piston out.

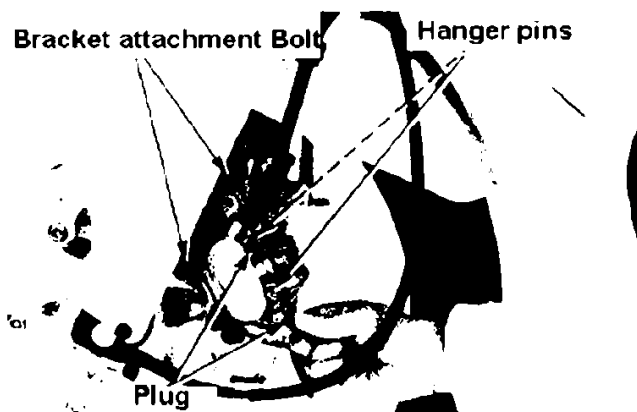

**Brake disk inspection**

Measure the thickness of the brake disk  
 $\leq 3.5\text{mm} \rightarrow \text{Replace}$

measure the deflection of the disk  
 $\geq 0.3\text{mm} \rightarrow \text{Replace}$



**Master cylinder**

**Detachment**

Bleed the brake fluid (15-3)  
 Remove the rear view mirror.  
 Loosen the brake hose joint bolt and disconnect the brake hose from the master cylinder.  
 Remove the master cylinder holder bolt and detach the master cylinder from the steering handle.

- Keep the brake fluid away from painted, plastic and rubber surfaces.
- Cover the hose joint to prevent the brake fluid spilling.

Detach the brake lever and the front brake light switch from the master cylinder.

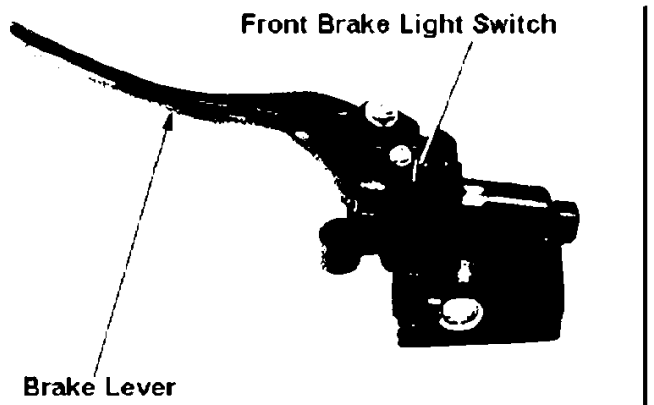
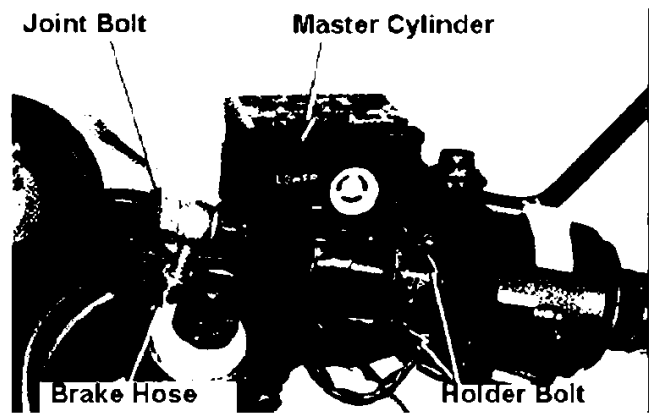

**Disassembly**

Remove the dust boot and then the snap ring.

Exc. tool Snap ring pliers  
07914-3230001

Snap Ring



Snap Ring Pliers

Remove piston, primary cup and the spring from the master cylinder and clean the master cylinder and reservoir with brake fluid.

- Clean each part with brake fluid and check air path by applying compressed air.
- Store all the detached parts to keep away from dust/debris.

Primary Cup

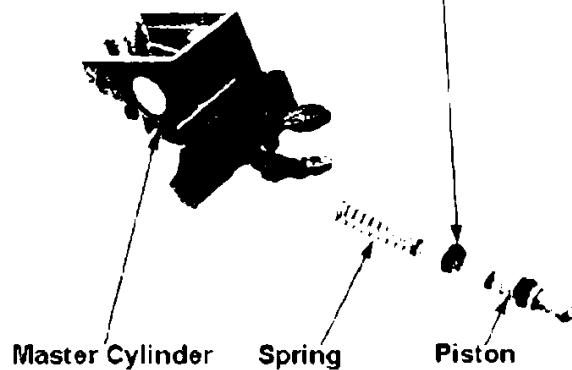

Master Cylinder

Spring

Piston

**Inspection**

Inspect the contact surface of the master cylinder (with master piston) for scratches and damage.

Measure the inner diameter of the master cylinder.

$\geq 14.055\text{mm} \rightarrow \text{Replace}$

Inspect the surface of the master piston for damage and scratch.

Inspect the piston cup for wear/damage.

Measure the outer diameter of the master piston.

$\leq 13.945\text{mm} \rightarrow \text{Replace}$

Piston

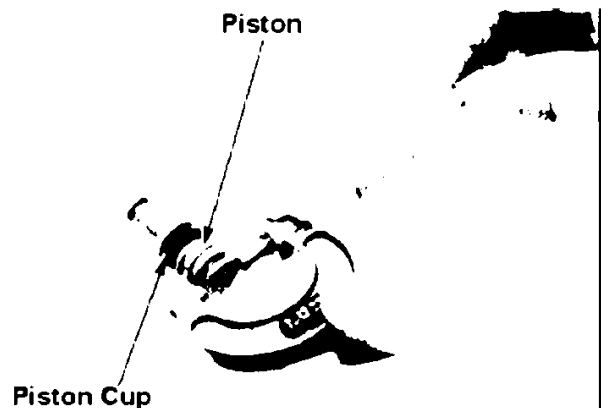

Piston Cup

**Assembly**

- Check all the parts are free from dust/debris.
- Do not re-use drained brake fluid.
- Replace the master cylinder piston, springs cup and the snap ring altogether when replacing.

Apply brake fluid to the piston cup and attach it to the piston.

Apply brake fluid to the inner surface of the master cylinder and primary cup.

Attach spring, primary cup and the piston to the master cylinder and attach a snap ring.

- Do not turn the lip surface over when attaching the cup.
- The smaller diameter side of the spring comes to the piston side.
- Attach the snap ring firmly into the groove.

Attach the boot.

Attach brake lever and front brake light switch to the master cylinder.

**Attachment**

Attach the master cylinder to the steering handle.

- Face the "UP" mark of the holder upwards and align the holder with the punched mark on the steering handle.
- Tighten the upper bolt on the holder first.

**Torque: 1.0 ~ 1.4kg-m**

Tighten the brake hose bolt with two new sealing washers.

**Torque: 2.5 ~ 3.5kg-m**

Bleed air (15-3)

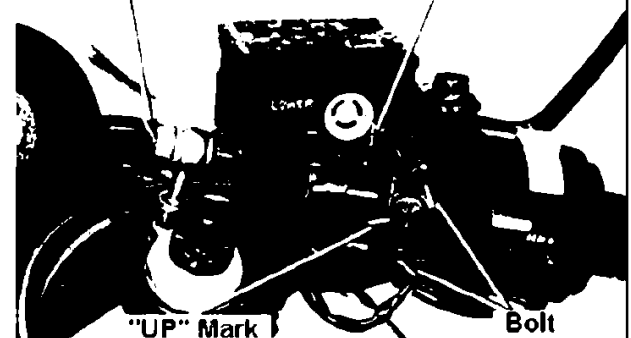
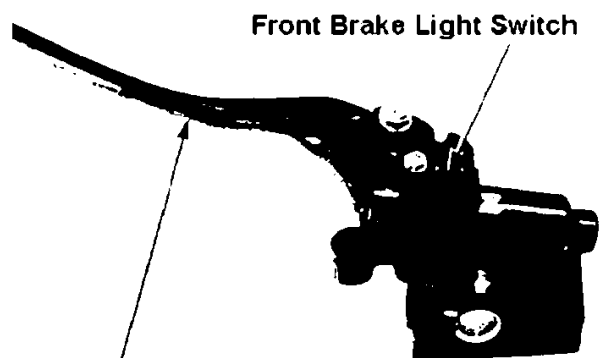
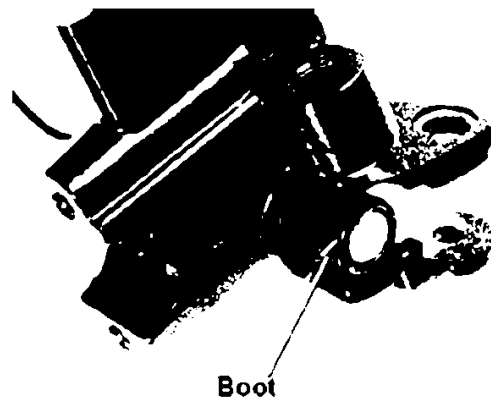
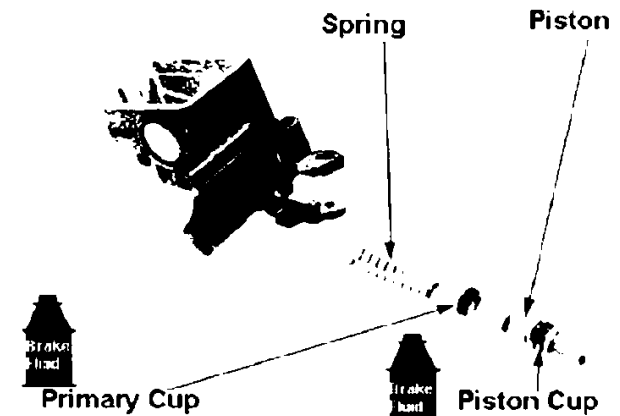



**Brake caliper**

**Detachment / disassembly**

Keep brake fluid away from painted, plastic and rubber surfaces.

Remove plugs and loosen hanger pins. Place clean oil pan underneath and disconnect the brake hose from caliper. Remove two bracket attachment bolts and detach caliper from the front fork.

Detach the following parts from the caliper:

- Caliper bracket
- Pads, pad springs
- Boot

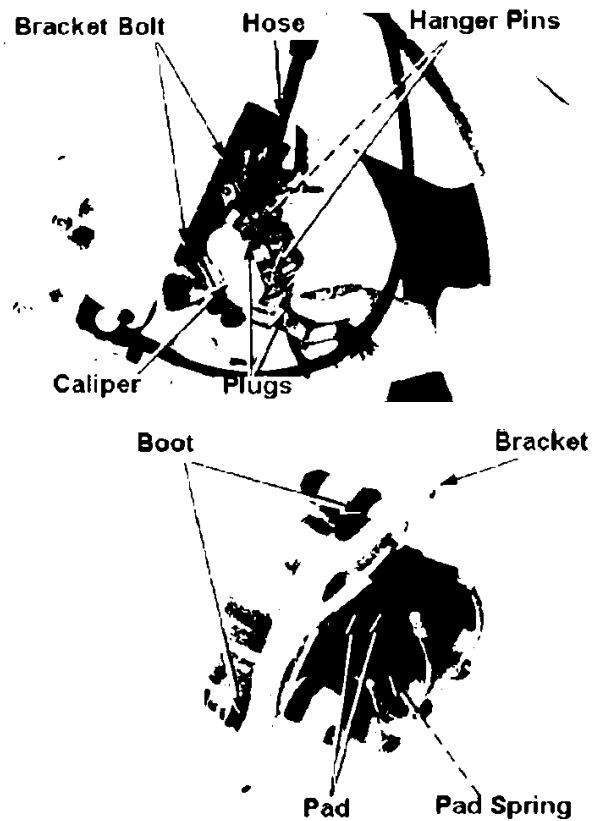

Hold the caliper with a cloth to prevent the piston and brake fluid coming out and tilt the piston downwards.

Gradually apply air (low pressure) to the brake hose attachment hole and detach the piston from the caliper.

- Do not use high pressure air and do not bring the air-gun too close.
- Do not insert your hand inside the caliper.



Detach piston seal and the dust seal by pushing them towards the bottom of the cylinder.

Do not damage inner surface of the caliper cylinder.

Clean inside of the caliper with brake fluid and remove dirt from grooves.



**Inspection**

Inspect the exterior surface of the caliper piston for scratch/damage.

Measure the outside diameter of the piston.  
 $\leq 26.91\text{mm} \rightarrow \text{Replace}$

Inspect the inner surface of the cylinder for scratch/damage.

Measure the inner diameter of the cylinder.  
 $\geq 27.06\text{mm} \rightarrow \text{Replace}$



**Caliper assembly / attachment**

- Make sure all parts are free from dust / debris before assembly.
- Do not re-use drained brake fluid.
- Replace piston seals and dust seals when disassembling the caliper.

Apply silicone grease or brake fluid to all inner surfaces of seals and attach to the caliper.

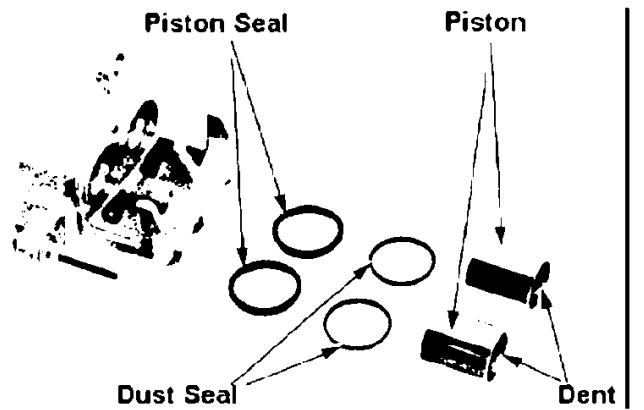

Attach pistons to the caliper.

Face the open side of the piston towards brake pads.

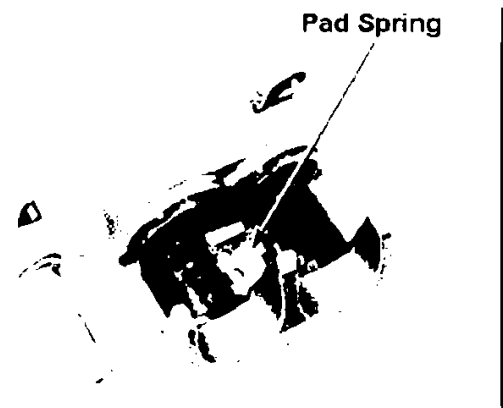

Attach the pad spring to the caliper.

Attach brake pad, boot and the bracket to the caliper.

- Apply silicone grease to the boot and the pin on the caliper bracket.
- Firmly set the boot to the groove on the caliper.

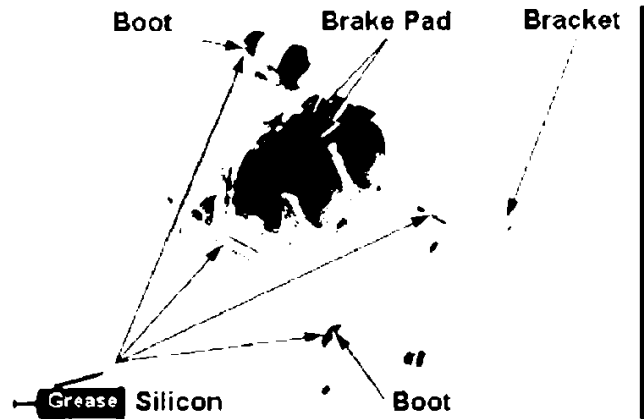

Attach hanger pin.

Attach caliper bracket to the front fork and tighten the bolt.

**Torque: 2.4 ~ 3.0kg-m**

Fix the brake hose and new sealing washers (two) with the brake hose bolt.

**Torque: 2.5 ~ 3.5kg-m**

Install hanger pin

**Torque: 1.5 ~ 2.0kg-m**

Install plugs

**Torque: 0.1 ~ 0.2kg-m**

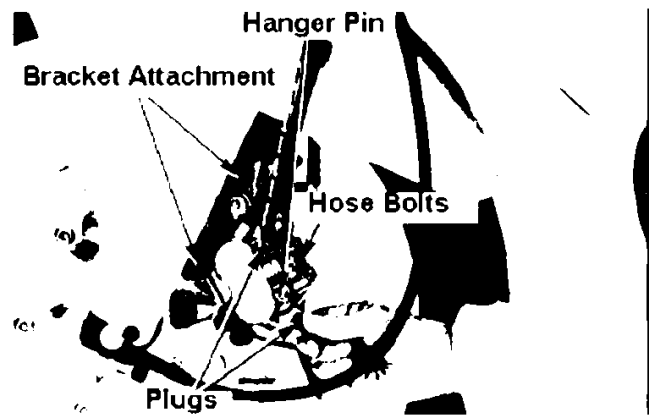

Fill the master cylinder with brake fluid and bleed air (15-3).

Service information	16 - 1	Rear fender	16 - 2
Exhaust pipe	16 - 2	Sub-frame	16 - 3

**Service Information****General Caution**

Service the exhaust pipe and the muffler when they are cooled down.
---

**Torque**

Exhaust pipe joint nut	0.8 – 1.2kg-m
Muffler attachment bolt	2.4 – 3.0kg-m
Rear fender A	0.7 – 1.1kg-m
Rear fender B	0.8 – 1.2kg-m
Tandem step holder	2.5 – 3.0kg-m
Sub-frame	4.5 – 5.5kg-m

**Exhaust pipe**

**Detachment**

Detach when the pipe and muffler are cool.

Remove the exhaust pipe joint nut.  
Remove muffler attachment bolt and nut and detach exhaust pipe.

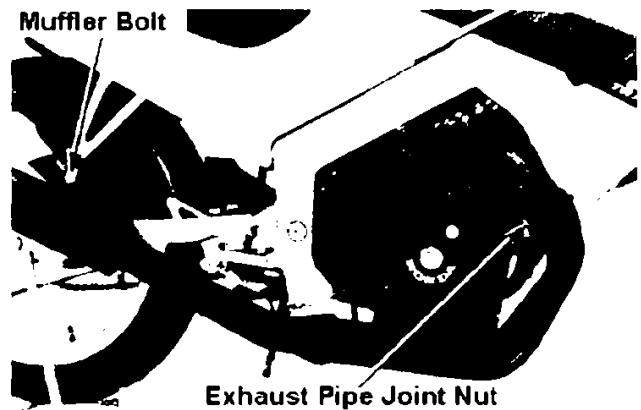

**Attachment**

Reverse the detachment procedure.

**Torque:**

Exhaust pipe joint nut	0.8 ~ 1.2kg-m
Muffler attachment bolt	2.4 ~ 3.0kg-m

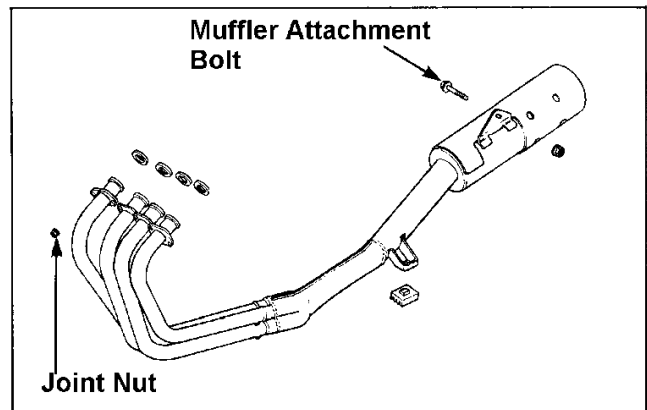

**Rear Fender**

**Detachment**

Remove the side cover.  
Remove bolts and detach the left tandem step holder.  
Remove five rear fender bolts.

Detach the rear fender B by pulling it towards the back and to the left.  
Remove seat and the rear cowl and disconnect couplers for the tail / stoplight.  
Remove four bolts and detach the rear fender A.

**Attachment**

Reverse the detachment procedure.

**Torque:**

Rear fender A	0.7 ~ 1.1kg-m
Rear fender B	0.8 ~ 1.2kg-m
Tandem step holder	2.5 ~ 3.0kg-m

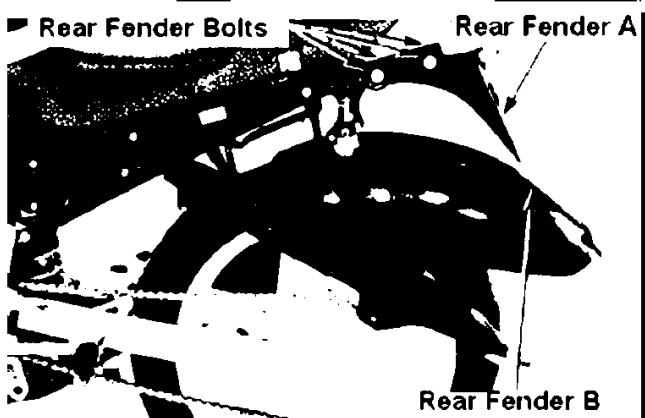
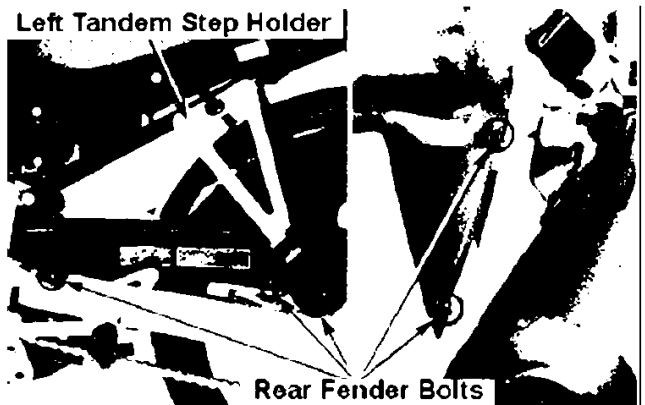

## Sub-frame

### Detachment

Remove the following items to detach the sub-frame.

- Fuel tank (4-3)
- Rear cowl (20-2)
- Tail-light (20-2)
- Regulator / rectifier (17-5)
- Battery case (5-11)
- Reservoir tank (5-11)
- Rear Fender (16-2)
- Tandem step holder
- Sub-frame attachment bolt

### Attachment

Reverse the detachment procedure.

#### Torque:

Sub-frame  
4.5 ~ 5.5kg-m

Tandem step holder  
2.5 ~ 3.0kg-m

Rear fender A  
0.7 ~ 1.1kg-m

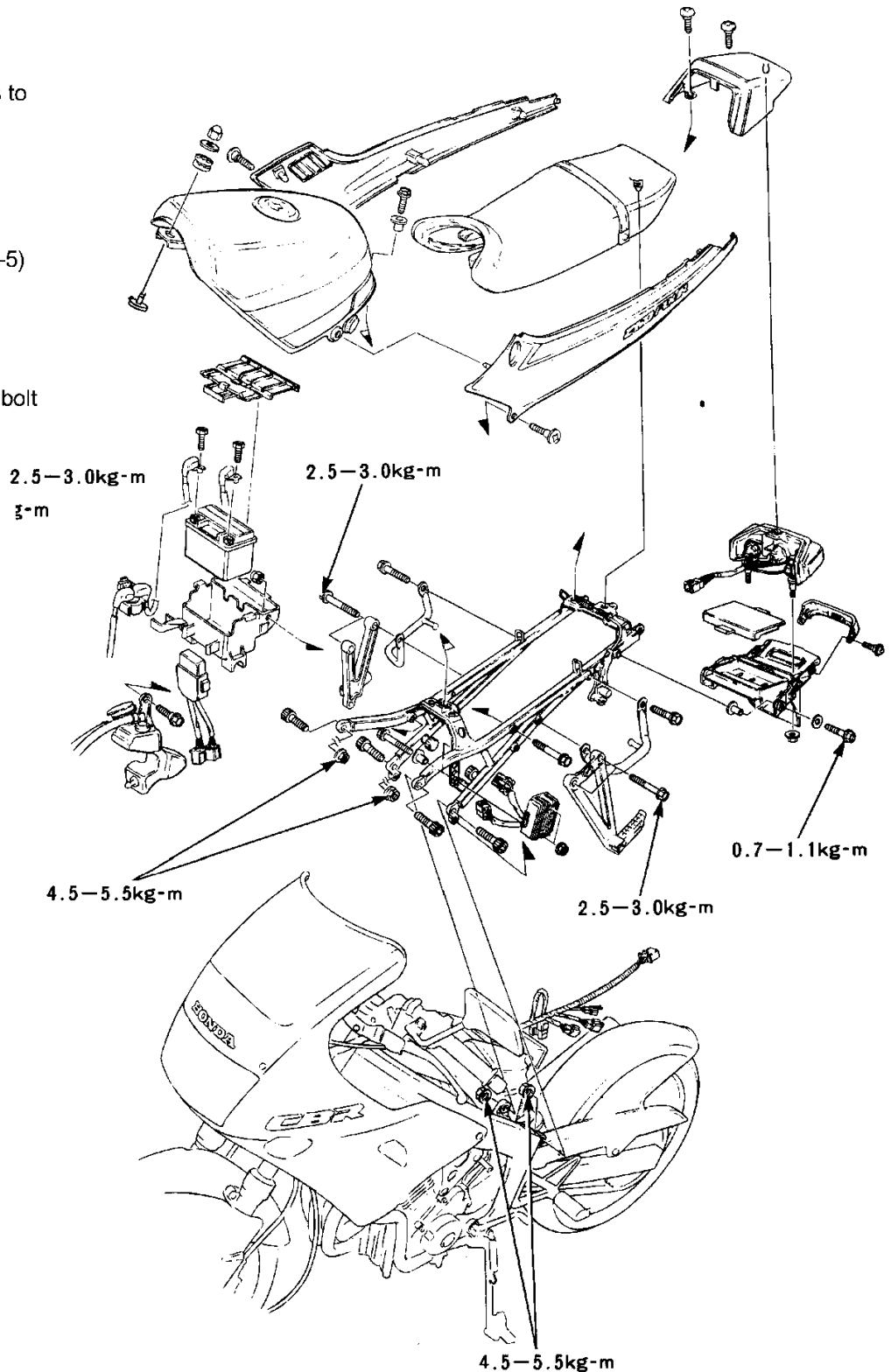

• Wiring

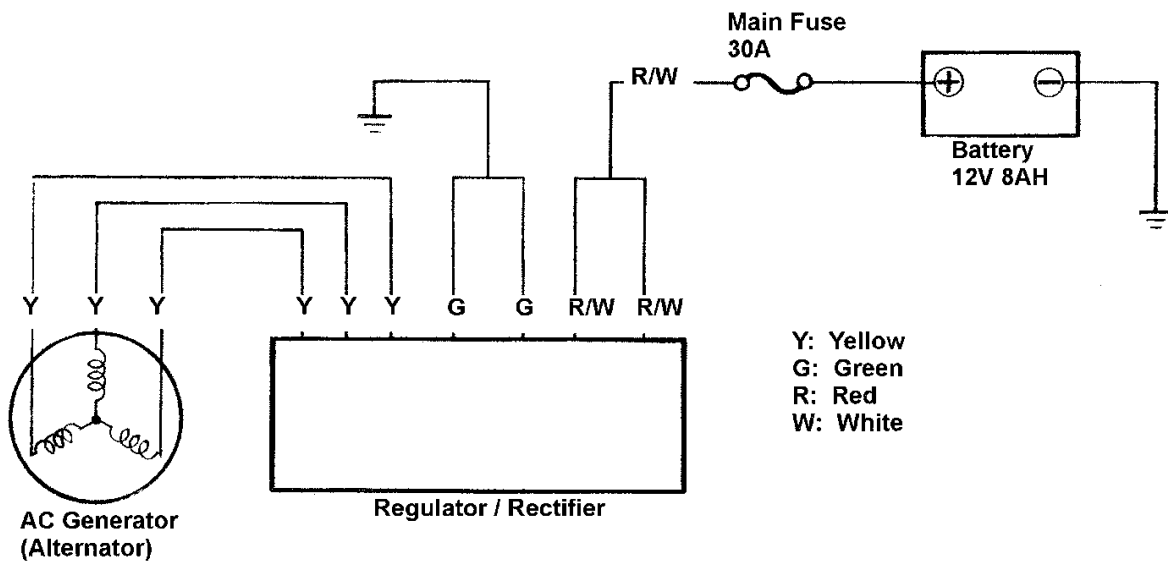
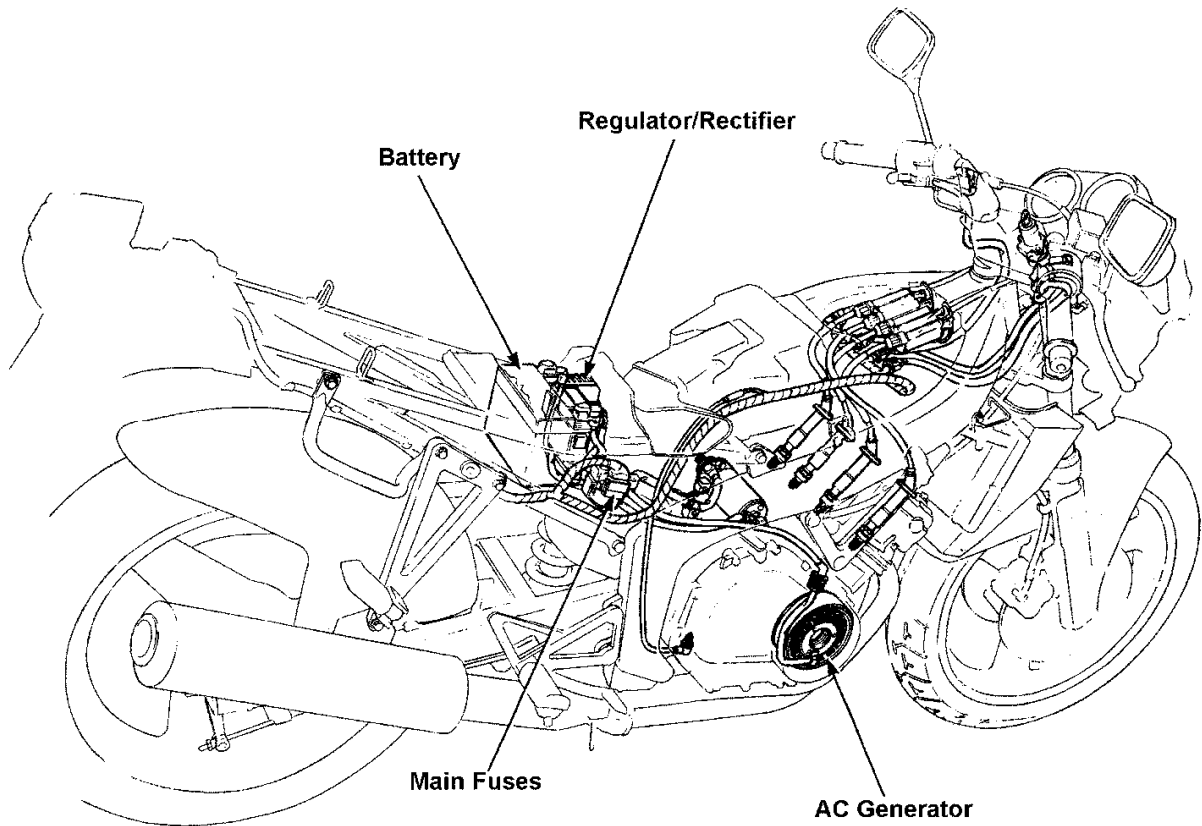

Wiring	17-0	Battery	17-3
Service information	17-1	Regulator / rectifier	17-4
Troubleshooting	17-2	AC Generator (Alternator)	17-5

**Service Information**

**General caution**

- Both sides of couplers should be same colour.
- Measured values may differ from standard values depending on environment.
- Alternator detachment / attachment (Sec. 10)
- Refer to 1-27 for total system troubleshooting.
- <Maintenance Free Battery>
- Water level check is not required thus no need to refill.
- Detach the battery from the frame when re-charging. Do not remove the fluid filler caps.
- Do not make rapid charge unless it is an emergency.
- Always refer to charging current and time written on top of the battery.
- Use a digital volt meter for charged status inspection.
- Do not install conventional battery when replacing the original maintenance free battery.

Item		Standard
Battery	Capacity	12V 8 AH
	Charging current	0.9A
	Discharge voltage	13.0-13.2V 20°
Charging commencement rpm (headlight ON, Low-beam)		≤ 1900rpm
Regulator / rectifier	Type	Non-contact point
	Regulator voltage	14.0 – 15.0V
Alternator coil resistance		0.3 –0.4Ω (20°C)
Alternator performance		18.5A – 5.000rpm

**Tools**

**Measuring tools**

Digital circuit tester	(Kowa)	07411- 0020000
Circuit tester	(Sanwa)	07308- 0020000
	(Kowa)	Th – 5H



**Troubleshooting**No current (with main switch ON)

- Battery discharge
  - Leak
  - Regulator / rectifier fault
  - AC generator fault
- Battery cables disconnected
- Fuses blown (inspect main fuses)
- Main switch fault
- Couplers disconnected / short circuit.

Re-charge system failure

- Connector or couplers disconnected / cut / short circuit between:
  - AC generator and regulator / rectifier (Y)
  - Regulator / rectifier and starter magnetic switches (R/W)
  - Starter magnetic switches and battery
- Regulator / rectifier fault
- AC generator fault

Low voltage

- Insufficient charging or discharging
- Regulator / rectifier fault
- AC generator fault

Intermittent current

- Battery cables connection fault
- Charging system connection fault
- Ignition system connection fault / short circuit

## Battery Detach / attachment

Remove seat, battery holder band and the battery cover.

Disconnect cables from battery terminals.

Disconnect negative side first, then positive.

Detach the battery.

Attach by reversing the above procedure.

Apply a little grease to the terminals after attaching the battery.

## Inspection of charged status (discharging voltage)

Measure the battery voltage.

Fully charged: 13.0 ~ 13.2V (20°C)

Undercharged:  $\leq 12.3V$  (20°C)

- Use a digital circuit tester
- Digital circuit tester: 07411-0020000
- Connect positive lead of the voltmeter to the positive terminal of a battery, negative lead to negative terminal.

## Leak test

If the battery is undercharged, disconnect the couplers on the regulator/rectifier (17-5) and disconnect the negative cable from the battery. Set the current meter between the negative terminal and the battery earth cable and inspect for leak.

Leak current should be  $\leq 0.1mA$

If the leak current is beyond the above value, inspect the regulator/rectifier and an alternator, and inspect wire harness, couplers and connectors for short circuit. Inspect the main switch for its operation (20-5).

If there is no leak or overcharged, measure the regulator voltage of the regulator / rectifier.

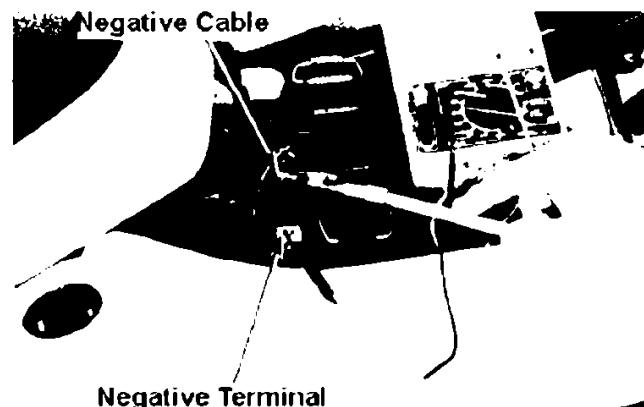
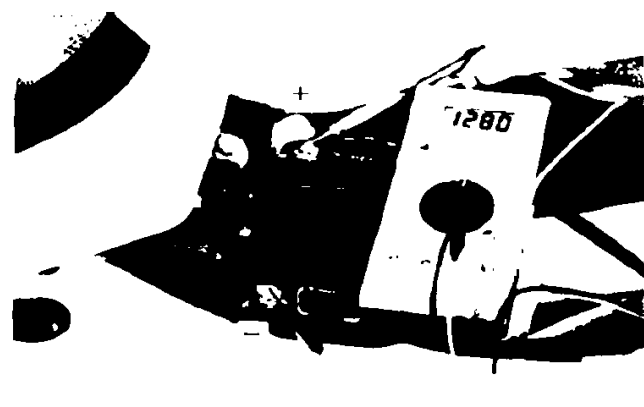
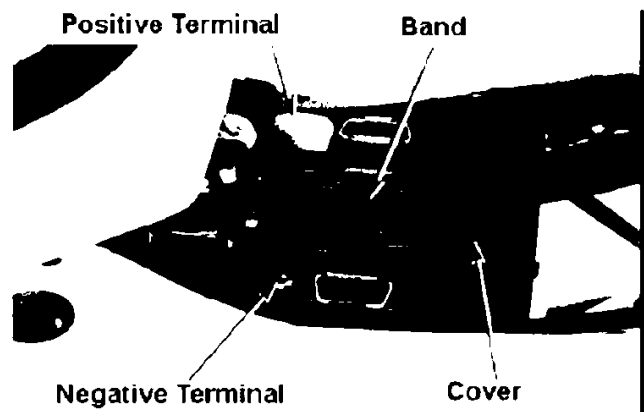

## Charging

**Connection:** Charger (+) = Battery (+)  
 Charger (-) = Battery (-)

- Keep out of fire
- Use the charger switch to start/stop charging. Connecting /disconnecting at the terminal cause spark and it may create explosion.
- Always refer to charging current and time specified on top of the battery.

- Do not make rapid charge except in case of emergency.
- Measure the voltage 30 min. after charging.

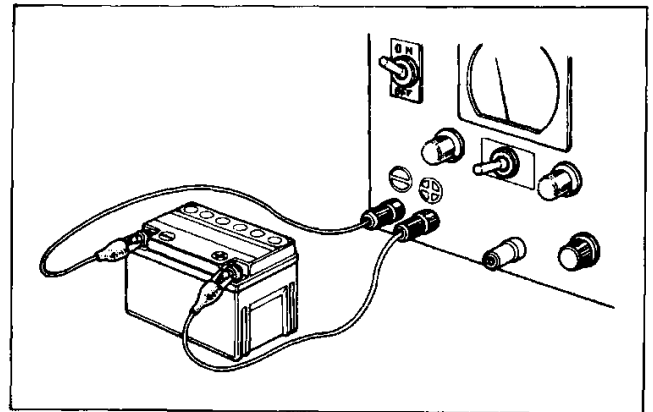

Charging current	Standard	0.9A
	Rapid	4.0A
Charging time	Standard	5 hours
	Rapid	1 hour
Fully charged voltage		13.0V

## Regulator / rectifier

### Regulator voltage inspection

- Inspect with fully charged battery

Warm up engine.

Stop the engine and remove a seat.

Start the engine and set a voltmeter between the battery terminals.

- Voltmeter (+) lead = (+) battery terminal  
 (-) lead = (-) battery terminal

Do not short circuit

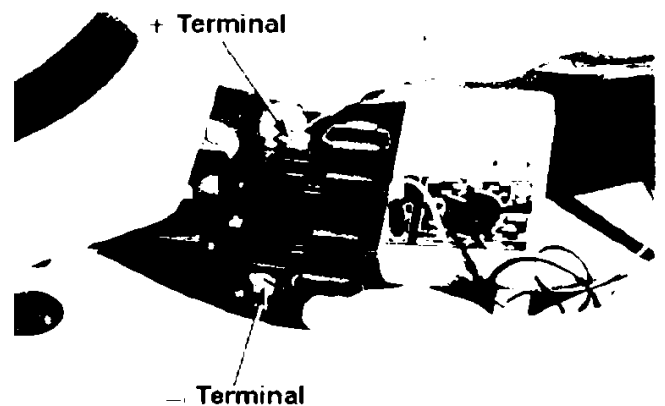

### Regulated voltage: 14.0 ~ 15.0V

If the voltage was out of the above range, inspect wire harness and couplers between the alternator and the battery and measure again.

If the voltage is still out of range, inspect the regulator/rectifier for its resistance (17-5) and inspect the alternator (17-5).

## Conduction inspection

Remove a seat and a left side cover.  
 Remove a regulator/rectifier attachment bolt.  
 Disconnect 4P and 3P couplers and detach the regulator/rectifier.

Test the conduction between each coupler on the table below.

If there is conduction in positive direction and no conduction in reverse direction, that part is ok.

Positive Direction: Conduction

	(+)	(-)
I	Yellow	Green
II	Red / white	yellow

Reverse Direction: Conduction

	(+)	(-)
I	Green	Yellow
II	Yellow	Red / white

## Alternator inspection

Detach a regulator/rectifier.  
 Measure the resistance between two yellow terminals on the alternator side.

**Standard: 0.3 ~ 0.4 Ω (20°C)**

Confirm there is no conduction between each terminal on the alternator and ground earth. If the resistance is out of the range above or if there is any conduction between the terminals and ground earth, replace the alternator.

These measurements can be conducted while the alternator is mounted on the engine.

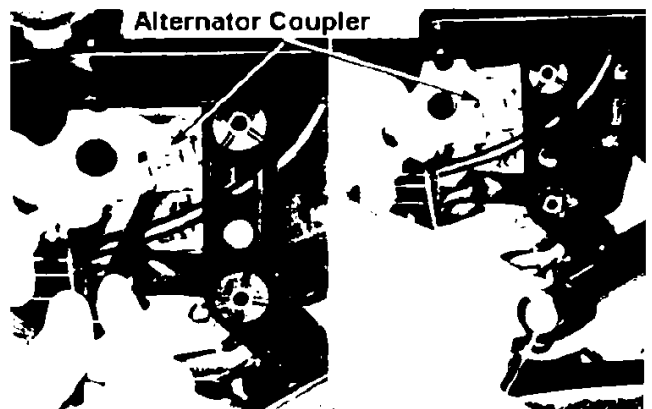
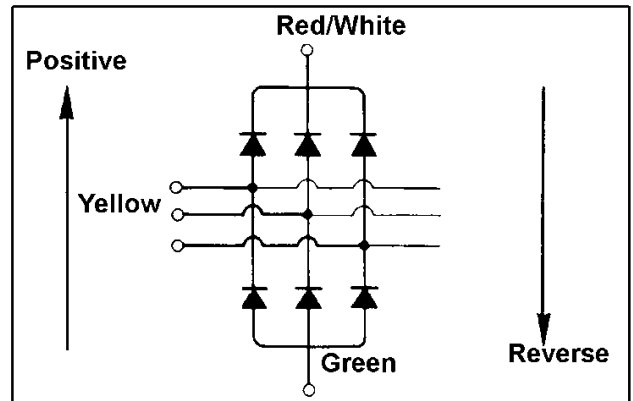
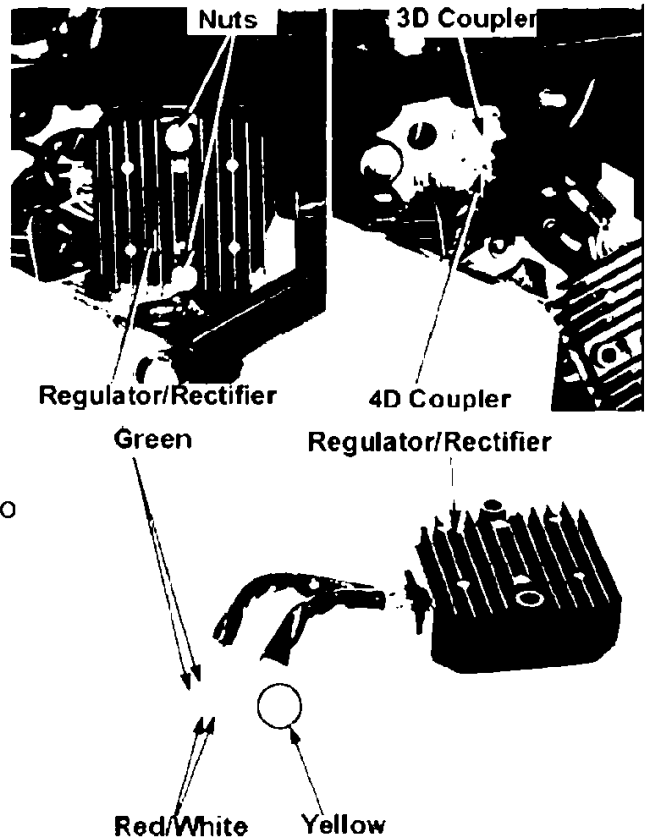

• Wiring

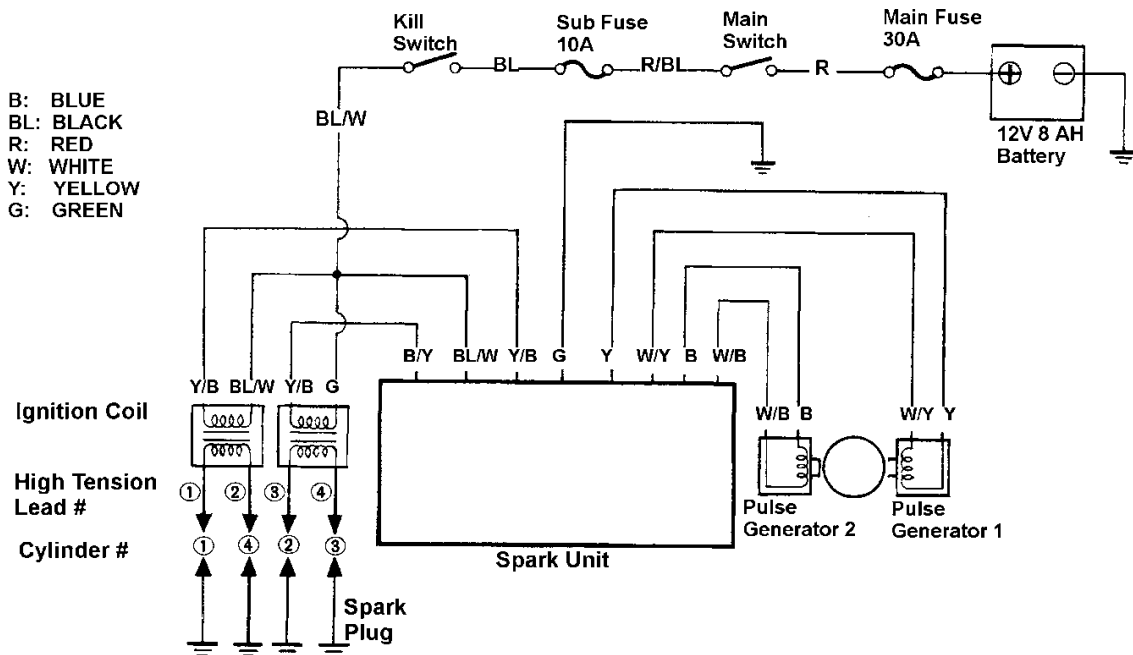
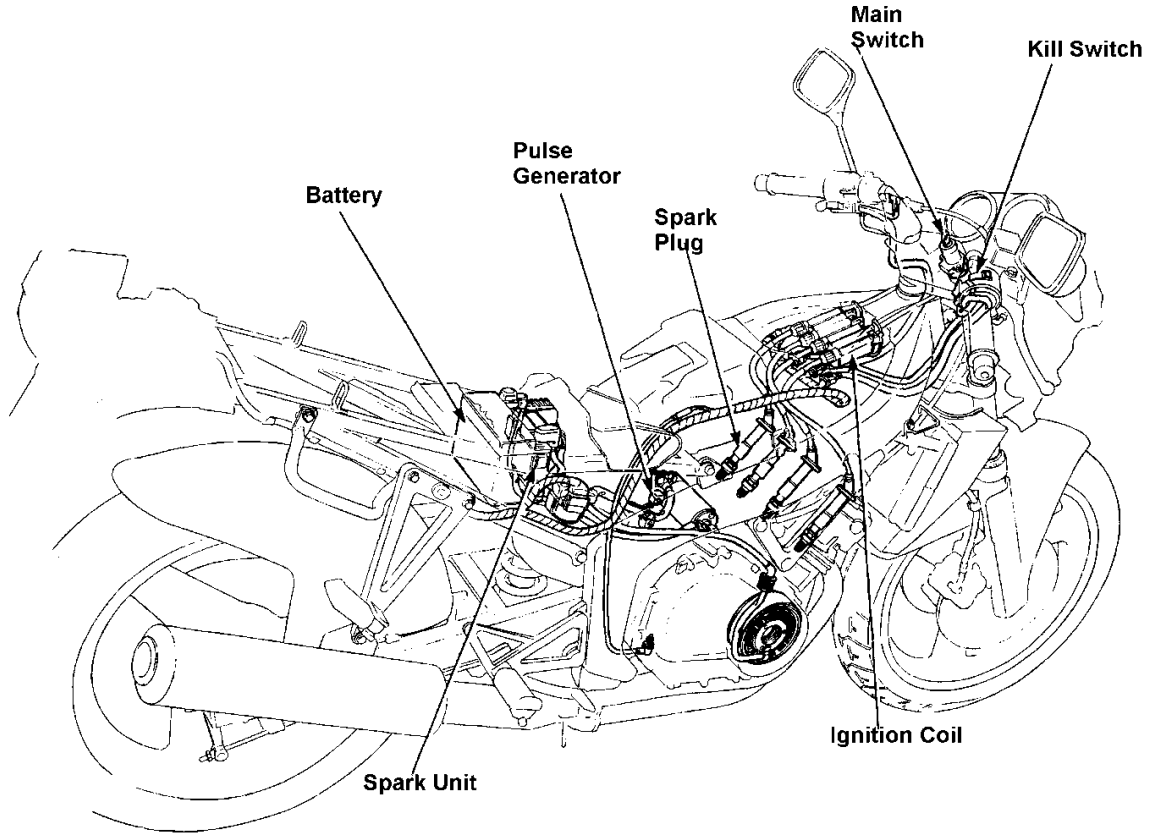

Wiring	18-0	Spark system inspection	18-3
Service information	18-1	Ignition coil	18-4
Troubleshooting	18-2	Pulse generator	18-5

## Service information

### General caution

- No adjustment is required as it is a transistor type ignition.
- Ignition timing (2-10)
- Spark plugs (2-9)
- Connect couplers with couplers of same colour.
- Resistance may vary with environment.

### Service standard

Item		Standard	
Spark plug		NGK	ND
		C8EH - 9	U24FE9
		C9EH - 9	U27FE9
Spark plug clearance		0.8 - .09mm	
Timing	"F" marking	20°BTDC/1.500rpm	
Ignition coil resistance (20°)	Primary coil		2.6 - 3.2Ω
	Secondary coil	With high tension lead	21 - 29k Ω
		Without high tension lead	13 - 17k Ω
Pulse generator coil resistance (20°)		315 - 385 Ω	

## Tools

### Measuring tools

Digital circuit multimeter	(Kowa)	07411 - 0020000
Circuit multimeter	(Sanwa)	07308 - 0020000

**Ignition system****Troubleshooting**No ignition spark from any of the plugs

- Kill switch is OFF
- Kill switch fault
- Main switch fault
- Pulse generator fault
- Spark unit fault
- Main fuse out
- Sub fuse out
- Wire connection fault / cutoff / short circuit between:
  - Starter magnetic switch and main switch (red)
  - Main switch and sub fuse (red/black)
  - Sub fuse and kill switch (black)
  - Kill switch and spark unit or ignition coil (black/white)
  - Ignition coil and spark unit (yellow/blue and blue/yellow)
  - Spark unit and earth (green)
  - Pulse generator and spark unit (white/blue and white/yellow)
- Battery undercharged

One particular plug does not give spark

- Plug fault
- High tension lead fault
- Ignition coil fault
- Wire connection fault / cutoff / short circuit between spark unit and ignition coil (blue/yellow, black/white and yellow/blue)
- Spark unit fault

- Rough / inadequate rpm
- Primary ignition circuit
  - Loose wiring
  - Kill switch fault
  - Main switch fault
  - Battery undercharged
  - Spark unit fault
  - Pulse generator fault
  - Pulse rotor fault

Secondary ignition circuit

- Plug fault
- High tension lead fault
- High tension lead cap screw loose
- Plug cap leak
- Ignition coil fault

- Ignition timing
  - Spark unit fault
  - Pulse generator fault
  - Pulse rotor fault

- Advance angle fault
- Pulse generator fault
- Spark unit fault
- Pulse rotor fault

## Spark system inspection

If there is no spark or weak spark, inspect the spark plug (2-9).

If the spark plugs are ok, inspect the following parts:

- Tightening of spark plug caps
- Battery status
- Main switch, kill switch, main fuse and sub fuse (Sec. 20).
- Corrosion of the starter magnetic switch coupler.

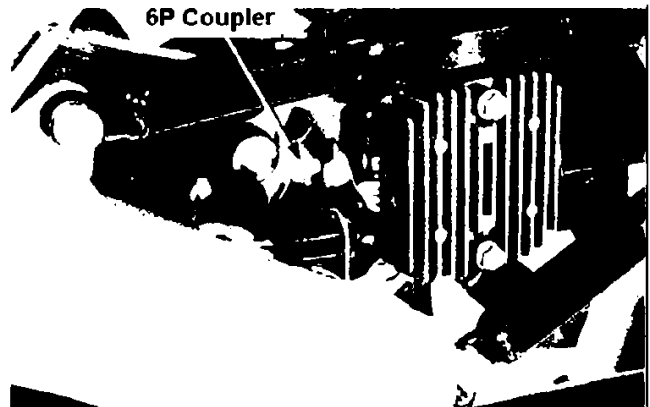

If the above items are fine, disconnect the 6P coupler from the spark unit and inspect the following items.

Loose, corrosion of spark unit coupler terminals.

If the above items are ok, inspect the conductivity and resistance of each male coupler terminal.

Terminals	Item	Standard
Black/white and yellow/blue Black/white and blue/yellow	Primary ignition coil	2.6 – 3.2 $\Omega$ 20°C
Black/white and green (main switch ON, kill switch RUN)	Battery voltage between main switch – kill switch – spark unit	Battery voltage  Set the range to DC-V. It should indicate around 12V. Connect (+) lead from the voltmeter to Black/White, (-) lead to Green.

If any of the items above were out of standard range, inspect following items:

- Ignition coil (18-4)
- Pulse generator (18-5)

If the above items are ok, inspect/adjust/replace wire harness, couplers and connectors.

## Spark unit inspection

Inspect pulse rotor (19-9) for deformation/damage on projections. If the timing is incorrect, replace the spark unit.

Inspect the timing again (2-10).

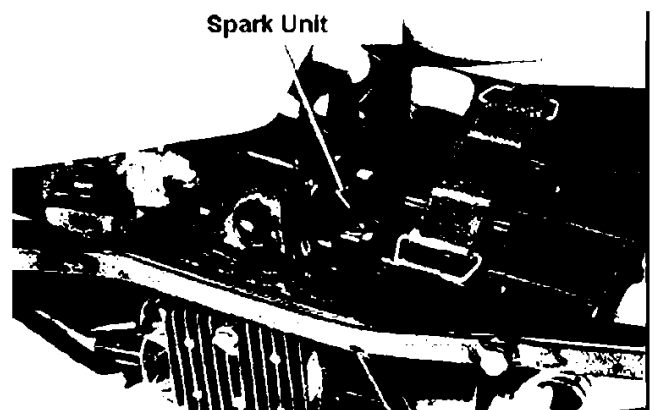



## Ignition coil

### Ignition coil inspection

Remove fuel tank (4-3).  
 Measure the resistance of the primary side of the ignition coil.

Resistance: 2.6 ~ 3.2Ω (20°C)

Inspect the conduction between the primary terminal and ground earth. No conduction should exist.

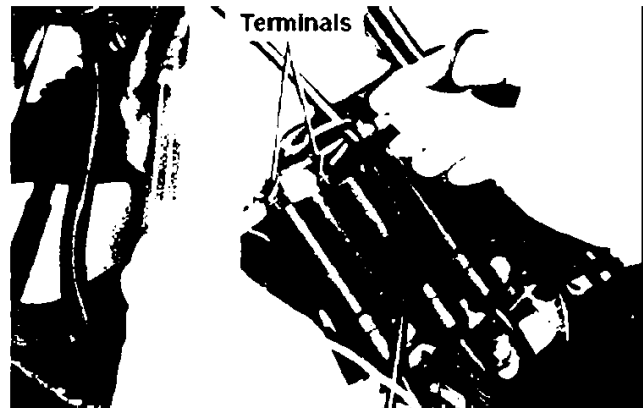

Remove plug caps from spark plugs and measure the resistance on the secondary side of the ignition coil.

Resistance: 21 ~ 29Ω (20°C)

If the resistance on the secondary side is out of the range, disconnect high tension leads and measure the resistance on the secondary coil.

Resistance: 13 ~ 172Ω (20°C)

If the measured resistance is within the above range, replace the high tension leads. If the resistance is out of the range, replace the ignition coil.

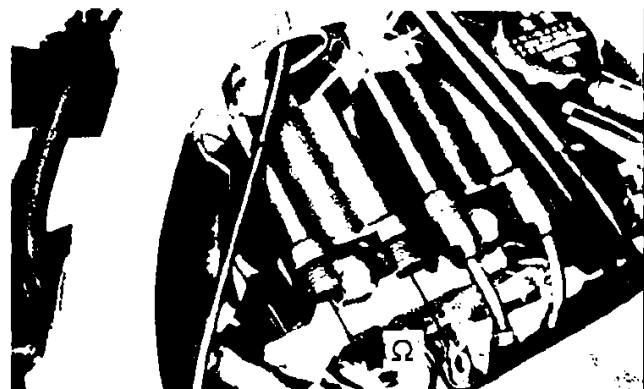

Cable Clamps

No. # 2 & 3 Ignition Coils

### Ignition coil replacement

Disconnect high tension leads from ignition coils.

Remove ignition coil attachment bolts and remove the coils.

Tighten the new ignition coil together with clamps.

Connect high tension leads to the coils.

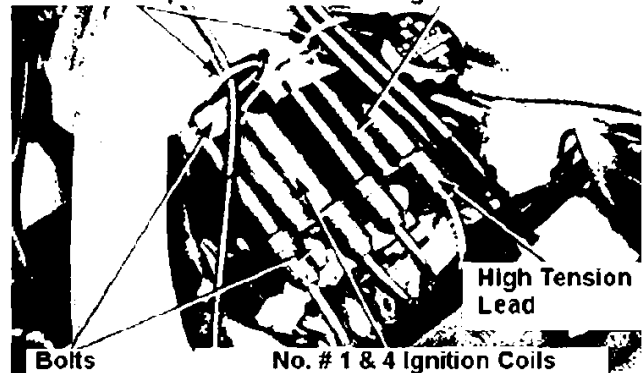

Bolts

No. # 1 & 4 Ignition Coils

#### Primary terminal connection

- #1 and 4 coils: Green terminal - Yellow/Blue wire
- Black terminal - Black/White
- #2 and 3 coils: Green terminal - Blue/Yellow
- Black terminal - Black/White

Install the fuel tank (4-3)

---

## Pulse generator

### Pulse generator coil inspection

Remove the left side cover.  
Disconnect the 4P coupler (white) for pulse generator wires and measure the resistance between coupler terminals (White/Blue – Blue, White/Yellow – Yellow) on the engine side.

Standard: 315 ~ 385Ω (20°C)

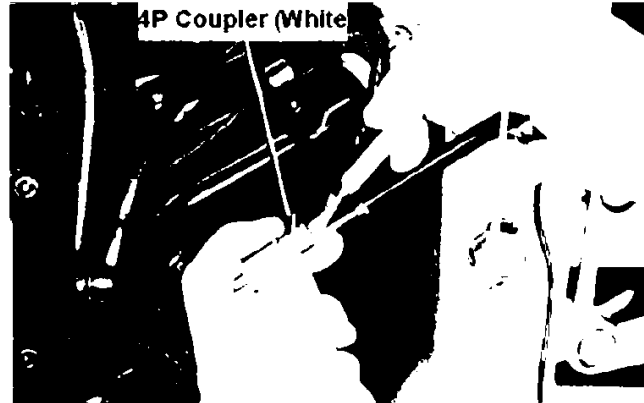

Check the conduction between each terminal and ground earth. No conduction should exist.

Refer to Sec.19 for pulse generator / rotor replacement.

• Wiring

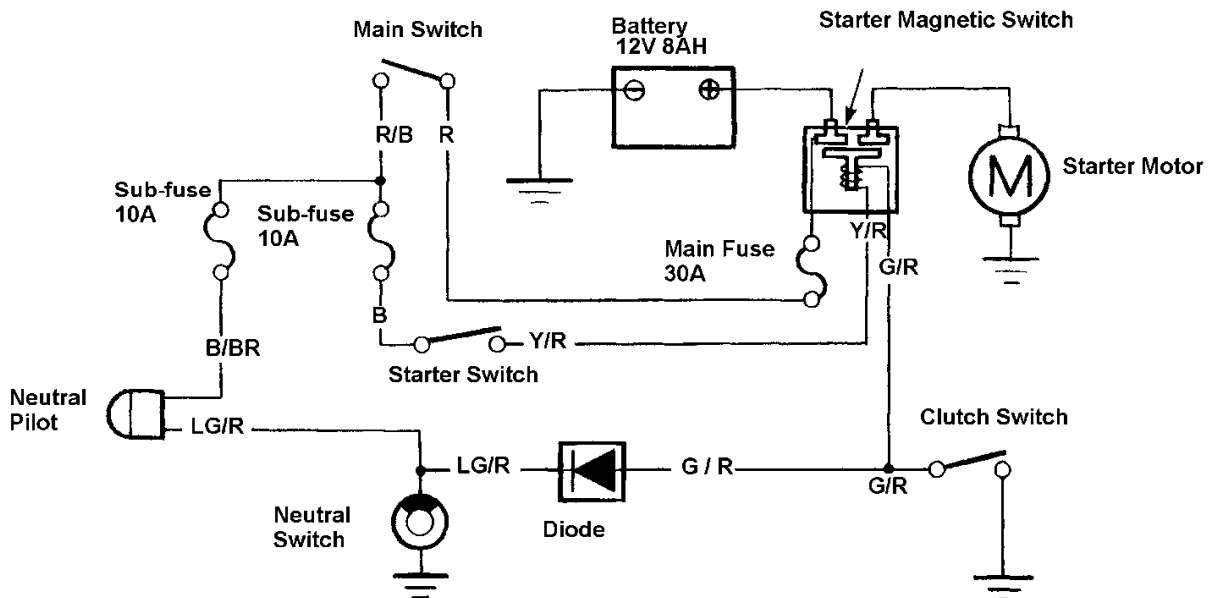
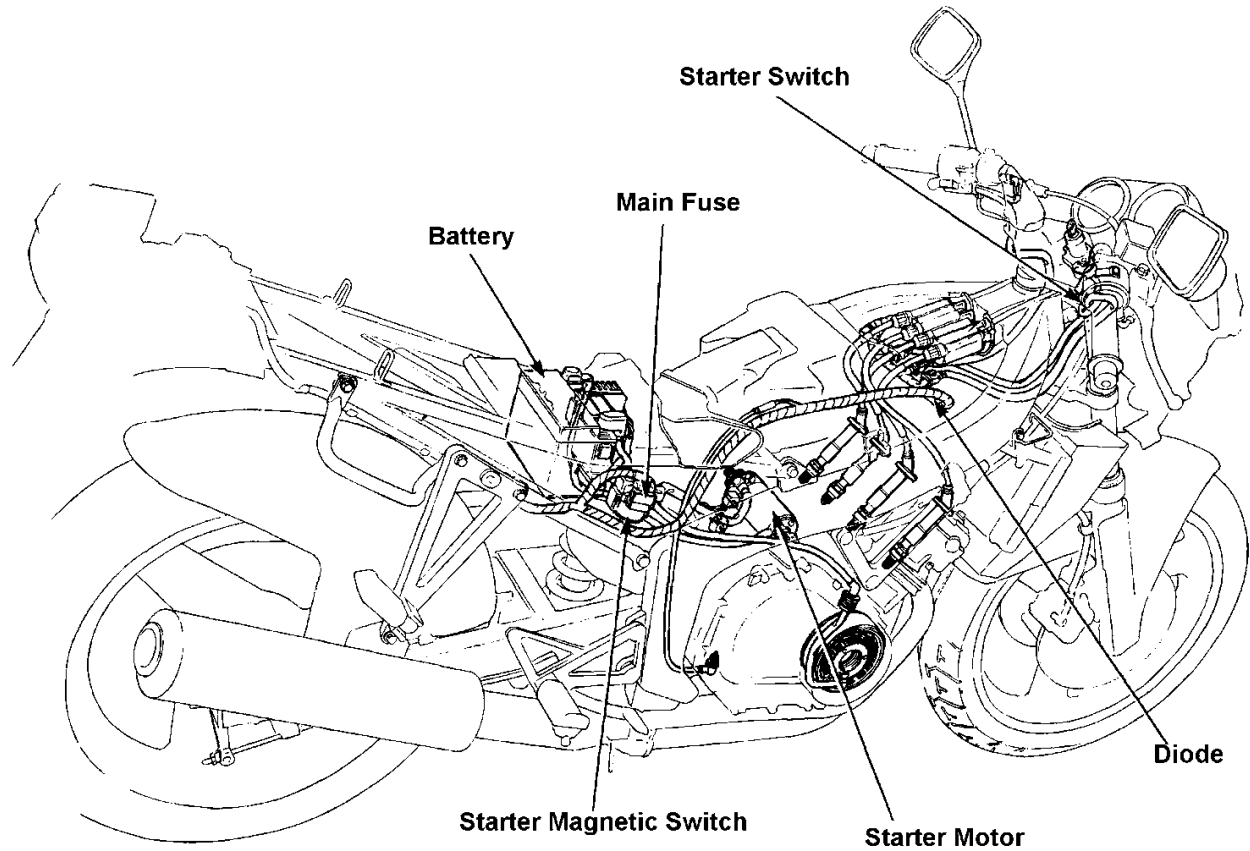

• Disassembly

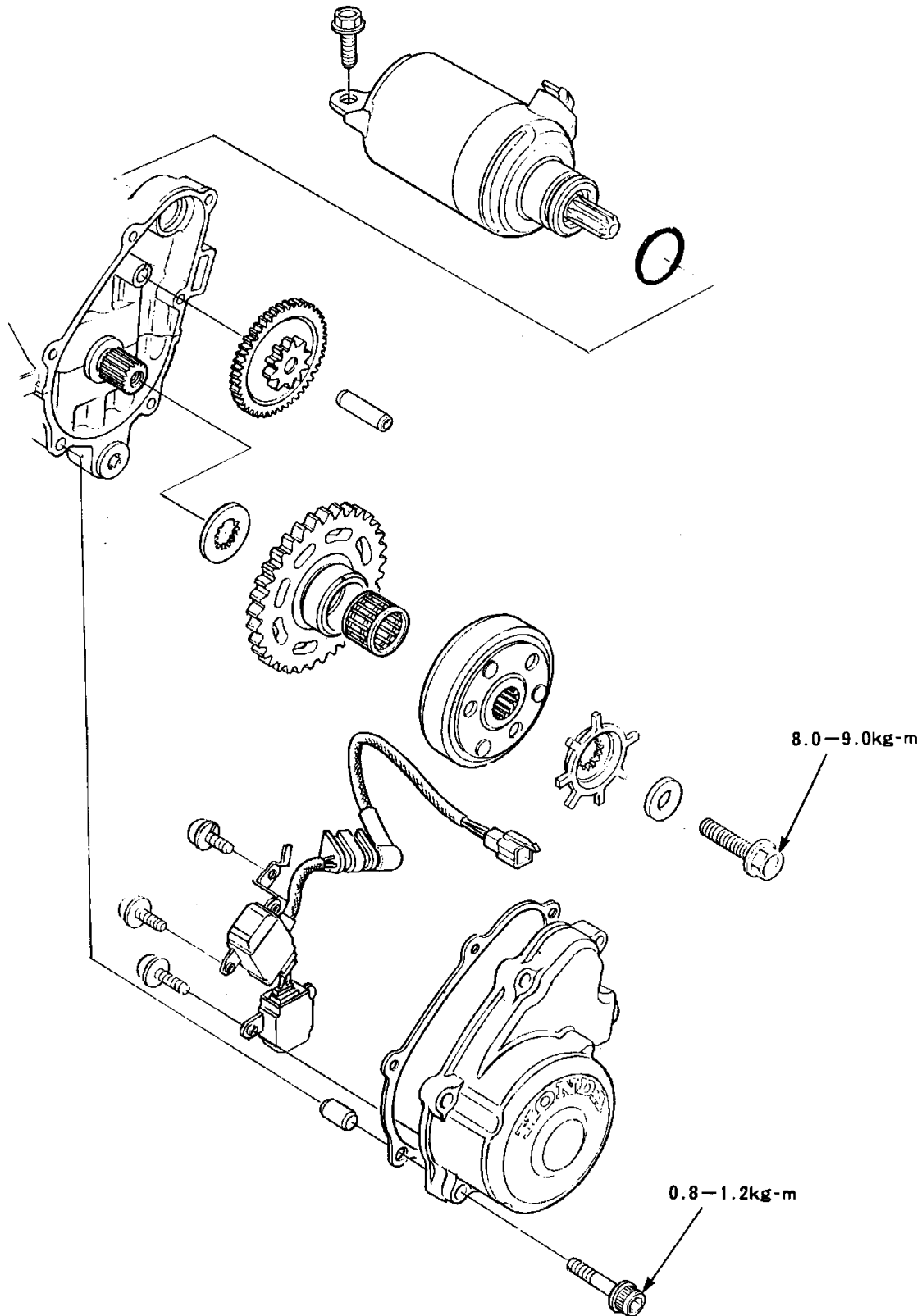

Wiring	19-0	Diode	19-7
Disassembly	19-1	Left crankcase cover removal	19-8
Service information	19-2	Starter clutch	19-9
Troubleshooting	19-3	Left crankcase cover installation	19-12
Starter motor	19-4		
Magnetic switch	19-7		

**Service information**

**General caution**

- The starter motor can be detached with the engine mounted.
- Pulse generator troubleshooting (Sec.18).

**Service standard**

Item	Standard	Standard	Limitation
Starter motor	Brush spring tension	630 –850g	-
	Brush length	11.00 – 11.05mm	4.5mm

**Torque**

Starter clutch	8.0 – 9.0kg-m
Left crankcase cover	0.8 – 1.2kg-m
Starter motor terminal cable	0.8 – 1.2kg-m

**Troubleshooting**Starter does not work

- Undercharged battery
- Main switch fault
- Starter switch fault
- Neutral switch fault
- Starter magnetic switch fault
- Wire harness, coupler or connector connection or open circuit
- Clutch diode fault
- Clutch switch fault
- Fuse blown (inspect sub, then main)

Starter motor operates but the engine does not spin

- Starter clutch fault
- Starter drive gear fault
- Starter driven gear fault

Insufficient power on the starter motor

- Battery undercharged
- High resistance in the circuit
- Motor catching debris/obstruction

Both starter motor and the engine spins but does not start

- Ignition system fault (Sec.18)
- Engine fault

## Starter motor

### Removal

Disconnect negative terminal on the battery prior to starting the work.

Remove the seat and side covers.  
Remove the fuel tank (4-3).  
Remove the air cleaner case (4-6).  
Remove screws and disconnect the starter cable from the motor.  
Remove two attachment bolts to remove the starter motor.

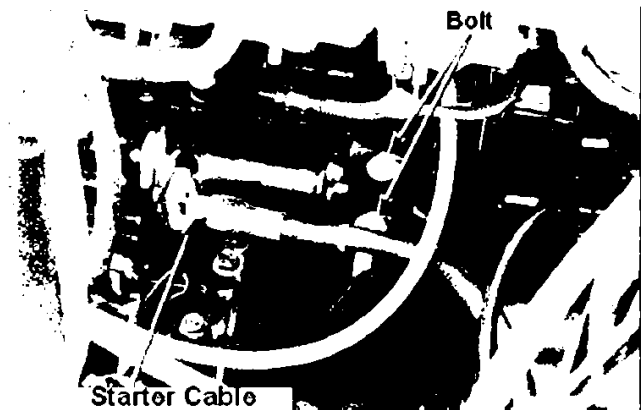

### Disassembly

Remove screws on the motor case.  
Remove the case cover.  
Pull out the armature.

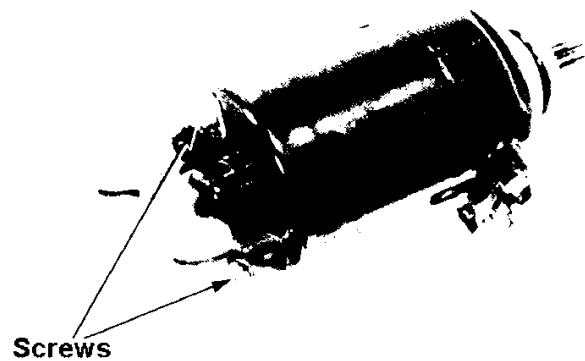

Check the number and position of shims

### Brush inspection

Inspect the brush length and the spring tension.

Brush length:  $\leq 4.5\text{mm}$  → Replace

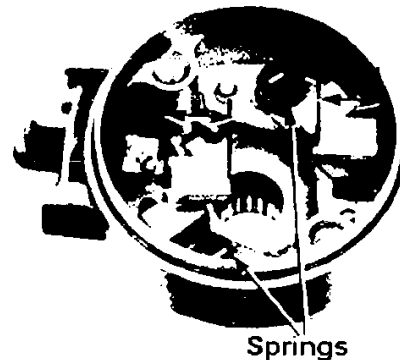

Inspect the conduction between terminals and the brush.

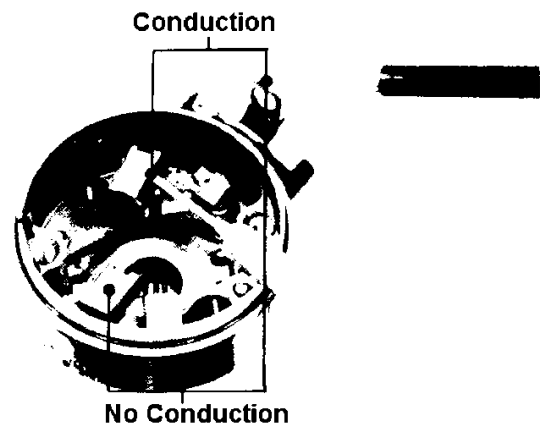

## Needle bearing, dust seal and O-Ring inspection

Inspect the needle bearing for wear, damage and loose fit.  
Inspect the dust seal for wear and apply small amount of grease.  
Inspect the O-Ring for wear.

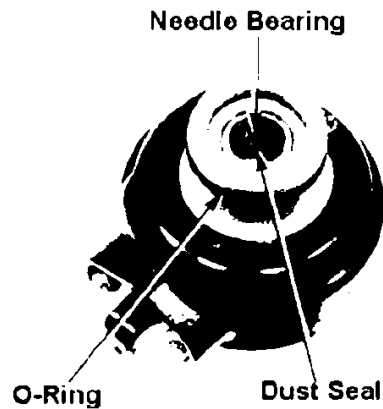

## Armature inspection

Check the colour of the cores.  
If two or more cores are an irregular colour, replace them as they indicate the short circuit of the coil.

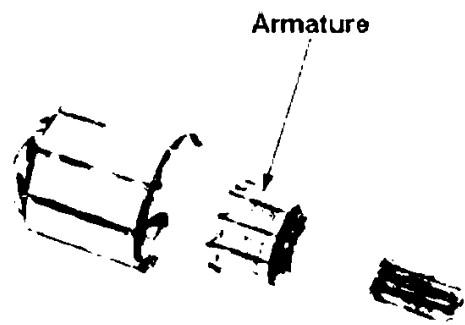

Check the conduction between armatures, between the armature and the shaft. It should have conduction between the armatures but not between the armature and the shaft.

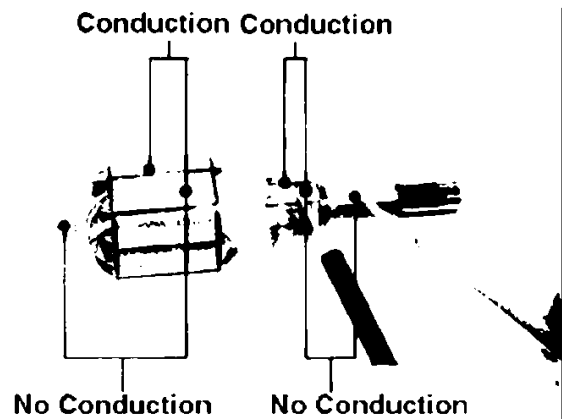



• **Assembly**

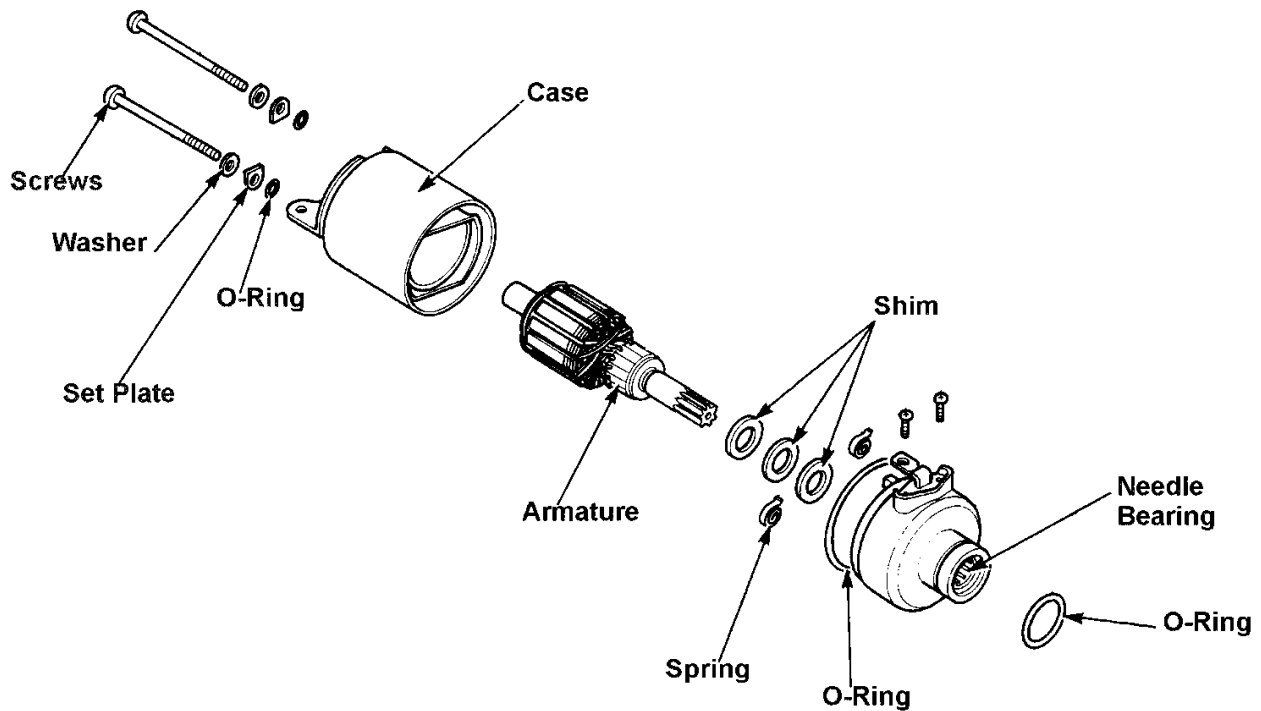

Inspect O-Rings for wear.  
 Set locking washers correctly to the slit on the cover and set shims in the order which was recorded when disassembling.  
 Set the brush and install the armature to the starter motor cover.  
 Align the slit on the cover and the punched mark on the case and attach the motor case.

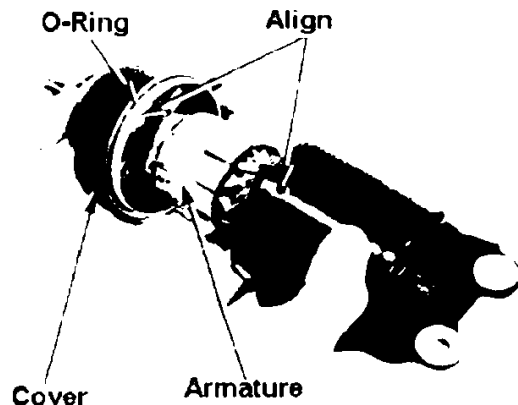

Attach washers, set plates and O-Rings to screws and tighten them.

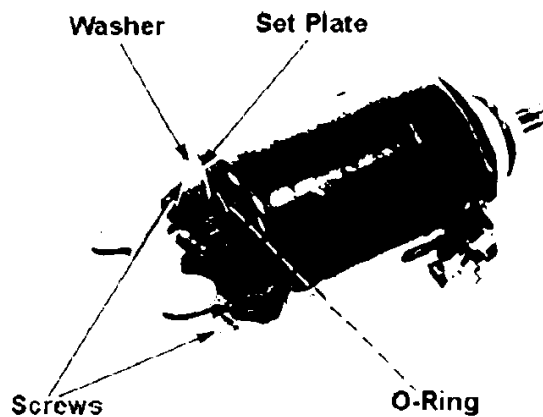

## Installation

Install the starter motor to the crankcase and tighten the bolt.

Attach and tighten the earth cable.

Connect cables to terminals and tighten to specified torque.

**Torque: 0.8 ~ 1.2kg-m**

Clamp the starter cable.  
 Install the air cleaner case.  
 Install the fuel tank (4-3).  
 Install side covers and the seat.

## Magnetic switch

### Inspection

Turn the ignition switch "ON" and push the starter button. A click sound should be heard and the starter motor should work.

### Removal

Disconnect the coupler from the magnetic switch.  
 Disconnect the cable from (-) terminal of the battery.  
 Pull out the magnetic switch and disconnect cables from terminals.

### Conduction check

Connect a multimeter to the terminals of the magnetic switch.

### Installation

Reverse the procedure of removal.

### Diode

#### Removal

Remove the fuel tank and remove the diode attached to the wire harness.

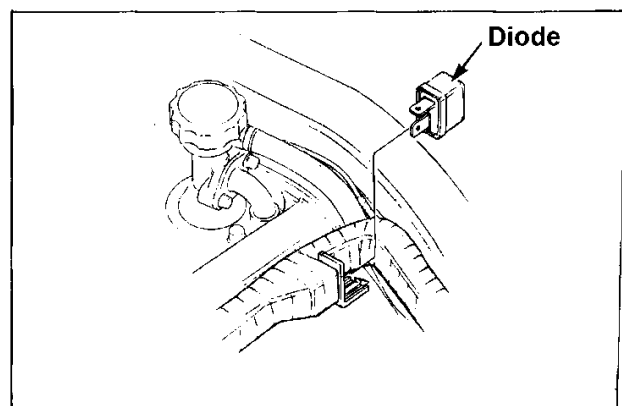
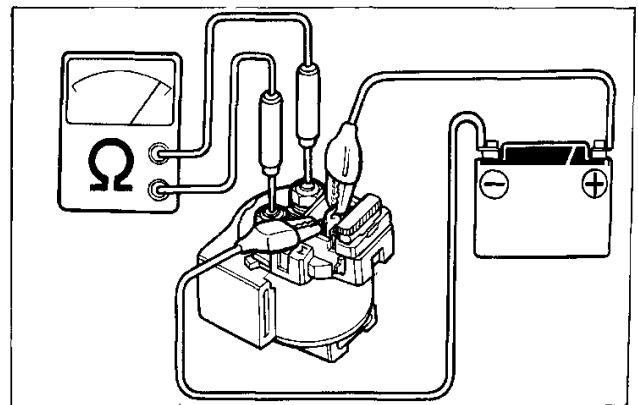
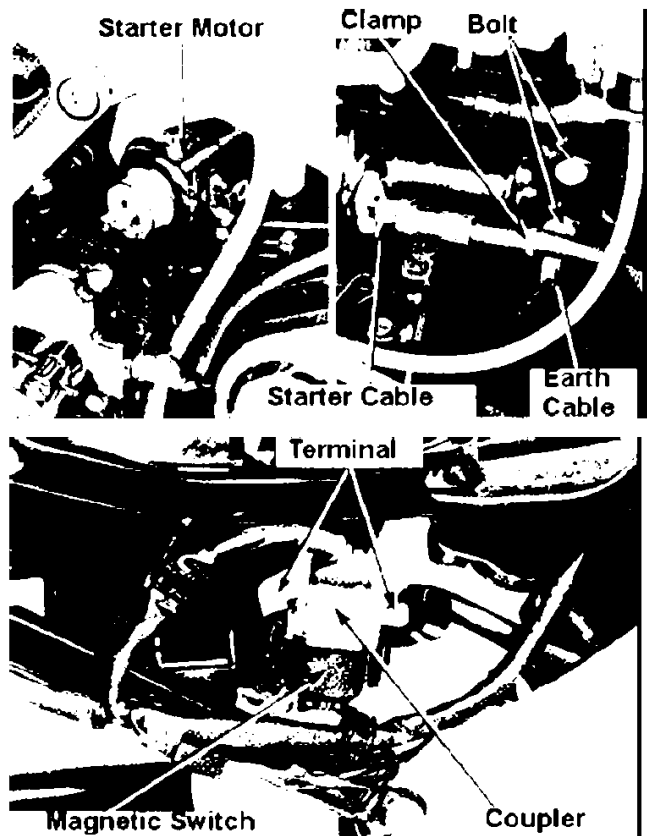

### Inspection

Inspect the conductance with an ohmmeter.  
Conduction occurs in one direction only.

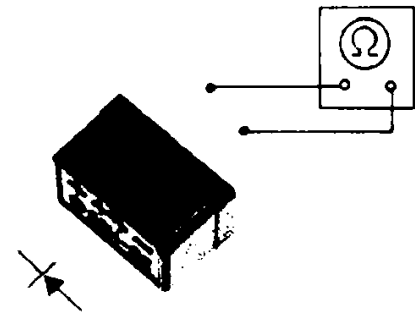

### Installation

Reverse the removal procedure.

### Left crankcase cover removal

Drain engine oil (2-16).  
Remove the seat.  
Remove the left side cover.  
Disconnect the pulse generator 4P coupler.

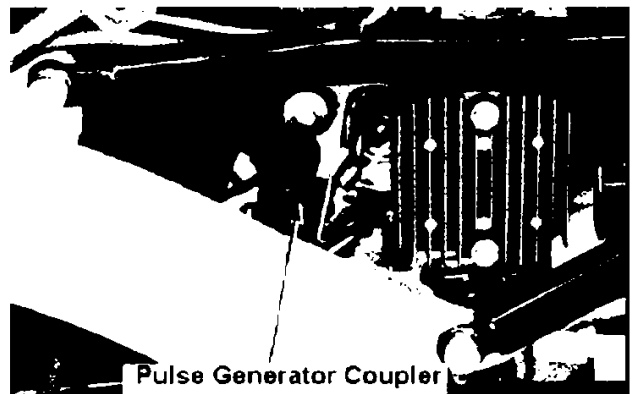

Remove bolts and remove the left crankcase cover.

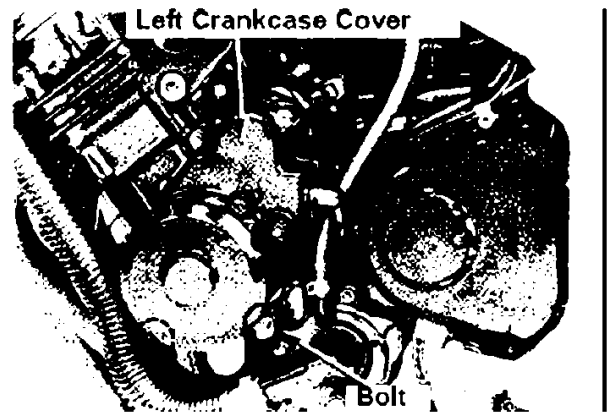

Remove the gasket and the knock pin.

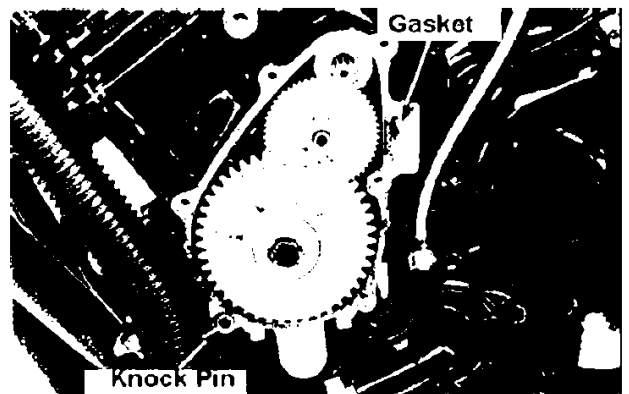

## Pulse generator removal

Remove the grommet.

Remove five socket bolts and remove the wire clamp and the pulse generator.

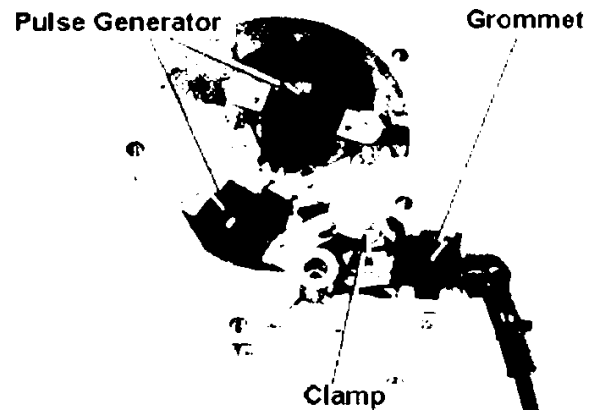

## Starter clutch

### Removal

Remove starter clutch attachment bolt.

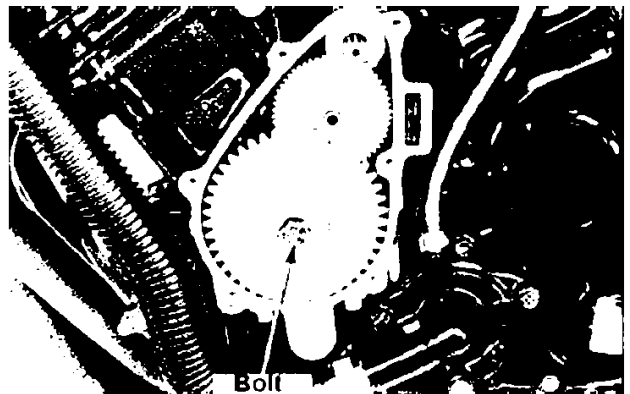

Remove pulse rotor.

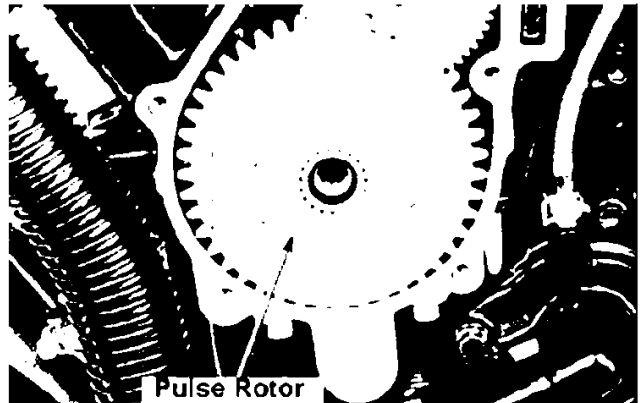

Remove starter driven gear with ASSY.

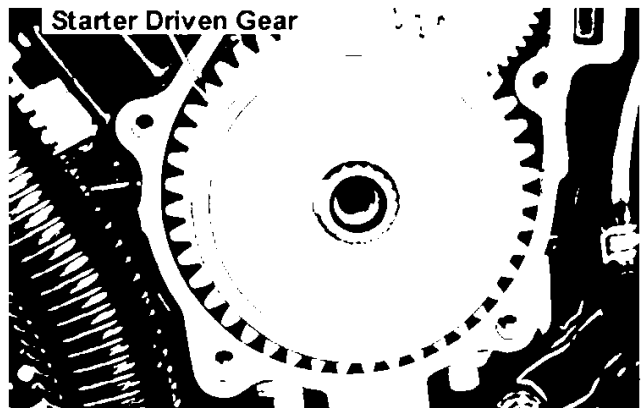

Remove washer.

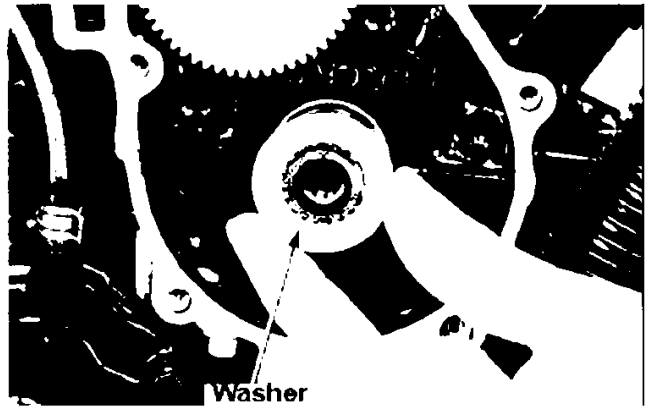

Remove starter drive gear and the shaft.

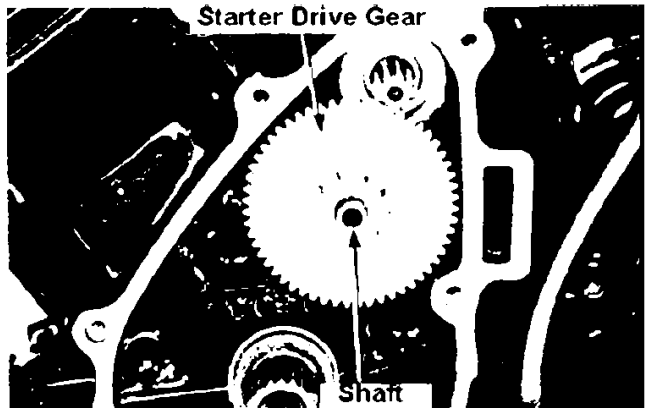

**Disassembly / inspection**

The starter driven gear should rotate only to the direction shown in the figure (counter-clockwise).

Detach the starter driven gear from one-way clutch.

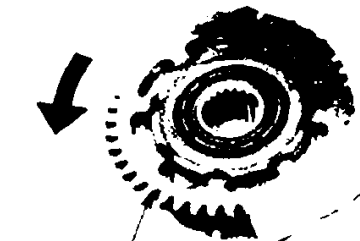

Inspect the starter driven gear for wear/damage.

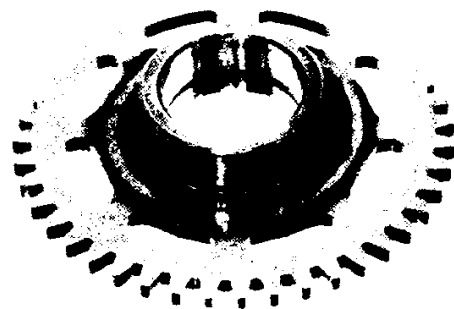

**Assembly**

Install the starter driven gear to one-way clutch.

Install the gear by rotating it to the direction shown.

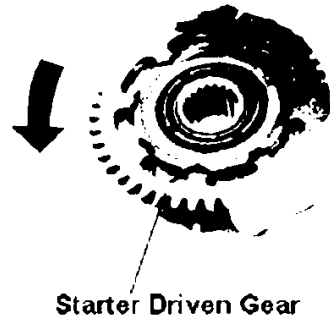

**Installation**

Attach the starter drive gear and the shaft.

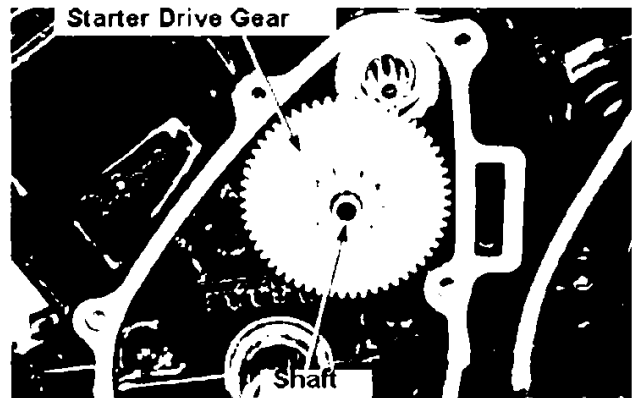

Align the wide gear on crankshaft with the wide slit on the washer and install the washer.

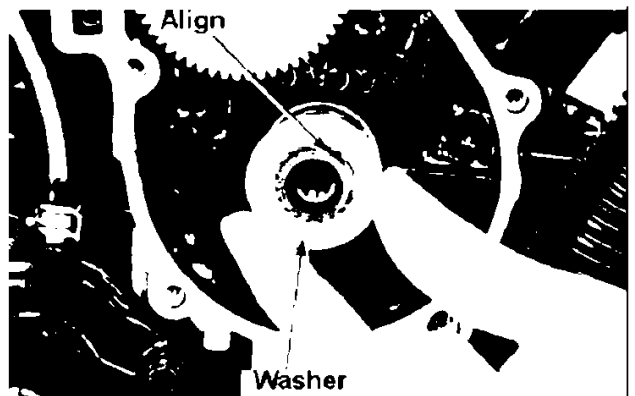

Align the wide gear on the crankshaft with wide slit on one-way clutch and install the starter driven gear.

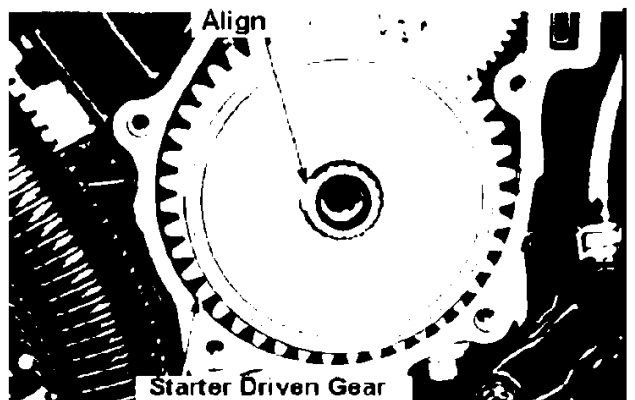

Align the wide gear on the crankshaft with the wide slit on the pulse rotor and install the pulse rotor.

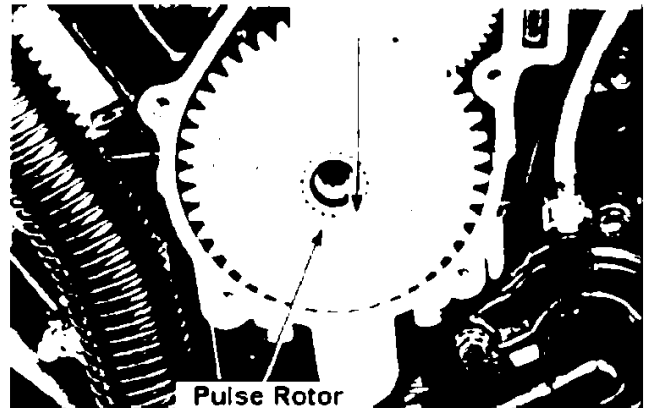

Install starter clutch attachment bolt and tighten with specified torque.  
Torque: 8.0 ~ 9.0kg-m)

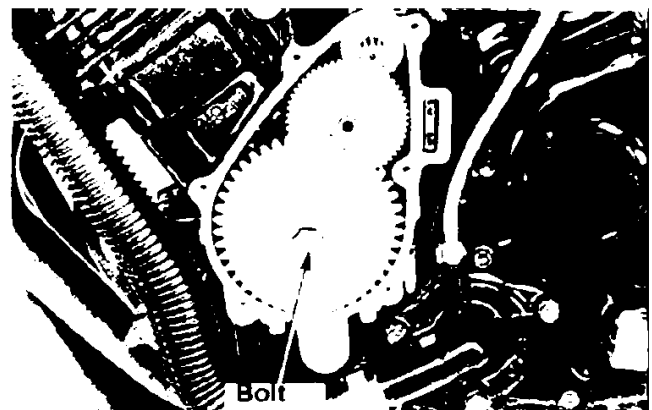

### Left crankcase cover installation

### Pulse generator installation

Correctly set pulse generators #1 and #2.  
Set the pulse generator wire clamp.  
Tighten five socket bolts.

- Apply screw locker
- Set so as to have moderate looseness on wires.

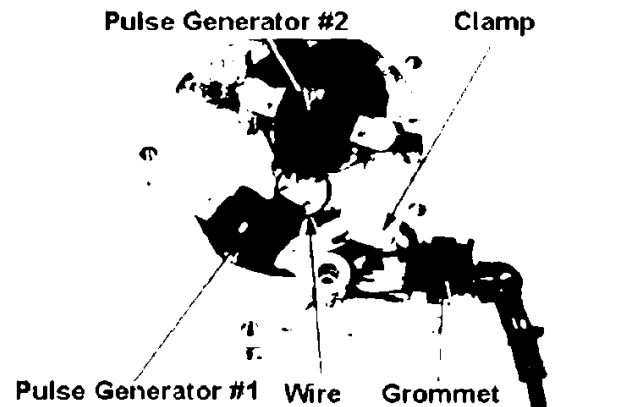

Attach grommet.

### Starter clutch cover installation

Install new gasket and the knock pin.

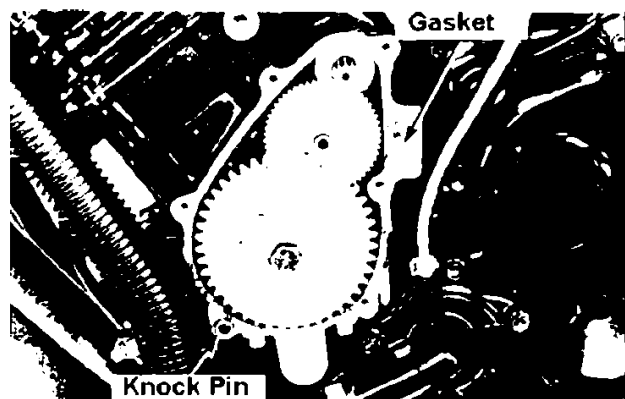

Install the left crankcase cover.

Apply screw locker only to bolt –A and tighten all bolts.

**Torque: 0.8 ~ 1.2kg-m**

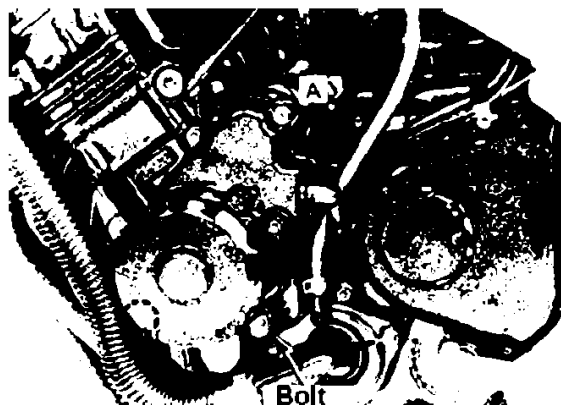

Set pulse generator wires and connect them to the spark unit 4P coupler (1-22).

Install the left side cover and the seat.

Fill engine oil (2-17).

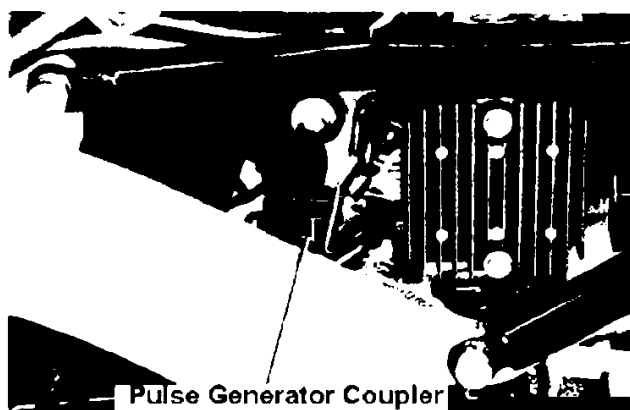



Service information	20-1	Water temperature gauge	20-8
Troubleshooting	20-1	Tachometer	20-8
Lens replacement	20-2	Cooling fan switch	20-8
Instruments	20-3	Neutral switch	20-9
Main switch	20-5	Brake light switch	20-9
Steering handle switches	20-6	Clutch	20-10
Oil pressure switches	20-7	Horn	20-10

**Service information**

**General caution**

- Connect same coloured leads. If colours are different on each side, there should be a coloured tube near the connector on one side. Connect couplers of same colours.
- Switch conduction test can be done without detaching from the vehicle.

**Standard**

Item	standard
Headlight bulb	12V 60 / 55W
Front turn signal bulb	12V 23 / 8W
Rear turn signal bulb	12V 23W
Stop / tail light bulb	12V 23 / 8W
Pilot lamps (excluding speed warning)	12V1.7W x 5
Speed warning light	12V 3W
Tacho, temperature gauge illuminator	12V 3.4W x 2
Speedometer illuminating light	12V3.4W. 12V 3W
Main fuse	30A
Turn signal, brakelight, horn, passing switch sub fuse	15A
Sub fuse other than the above	10A x 6

**Torque**

Ignition switch	2.5~3.0kg-m	Tail light	0.8~1.2kg-m
Headlight	0.3~0.5kg-m	Front turn signal	0.35~0.50kg-m
Instruments	0.8~1.2kg-m	Cooling fan switch	2.4~3.2kg-m

**Troubleshooting**

Lights do not illuminate

- Bulb out
- Switch fault
- Wires open circuit
- Fuse out (inspect a sub fuse under instruments before inspecting a main fuse).
- Battery discharged
- Wiring fault

Lights too dark

- Battery discharged
- Bulb fault

Unable to switch Hi-Lo off a headlight

- Bulb fault
- Dimmer switch fault
- Wiring fault

**Lens replacement**

**Headlight**

Remove the fairing (13-4)

Remove the bulb for the headlight

Do not touch the glass surface of the bulb by hand or a dirty glove or it may reduce the performance.

Remove four screws and remove a headlight case from the fairing.

Detach lens attachment clamps and remove a headlight lens.

Reverse the above procedure for installation.

**Torque: Headlight attachment vis:**

**0.3~0.5kg-m**

Attach the dust cover so as to have "TOP" marking on top.

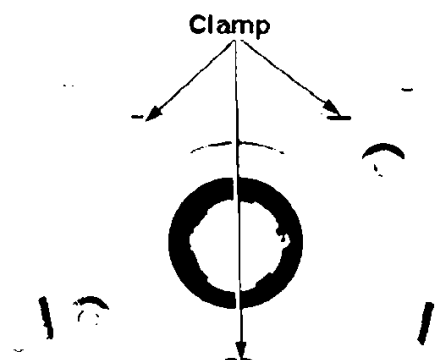
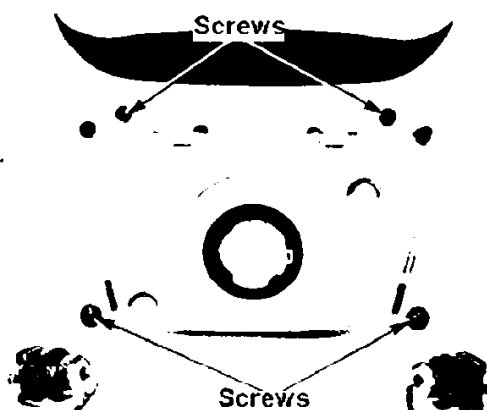

**Front turn signals**

Detach the fairing (13-4).

Remove turn signal lens attachment screws and remove the lens.

Reverse the procedure for installation.

**Torque: 0.35 ~ 0.50kg-m**

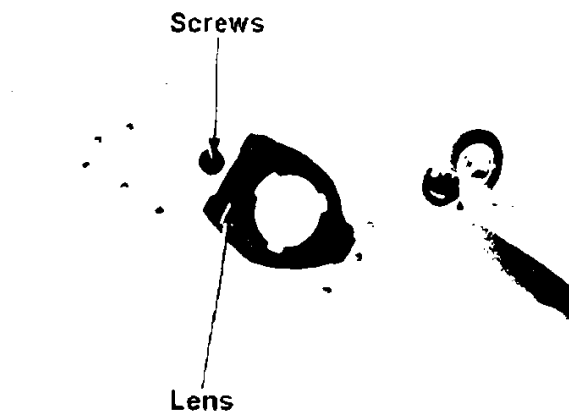

**Tail light**

Remove two screws and detach a rear cowl.

Disconnect the tail light coupler.

Remove two nuts underneath the rear fender A and remove the taillight.

Reverse the procedure for installation.

**Torque: 0.8 ~ 1.2kg-m**

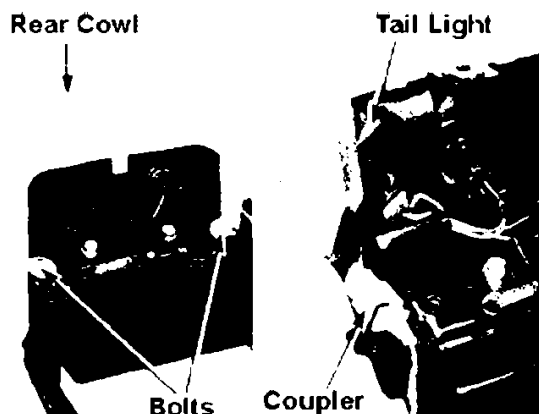

**Instruments**

**Removal**

Remove instrument stay bolts.

Disconnect the speedometer cable.

Disconnect instrument couplers.

Detach the wire harness from the clammer and remove instruments.

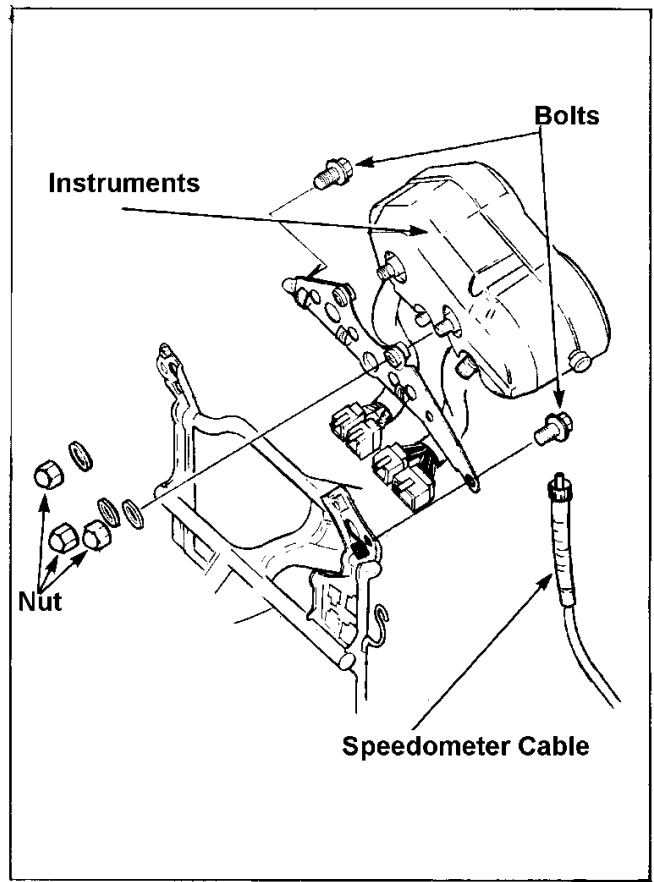

**Disassembly**

Remove four screws and remove the instrument lower cover.

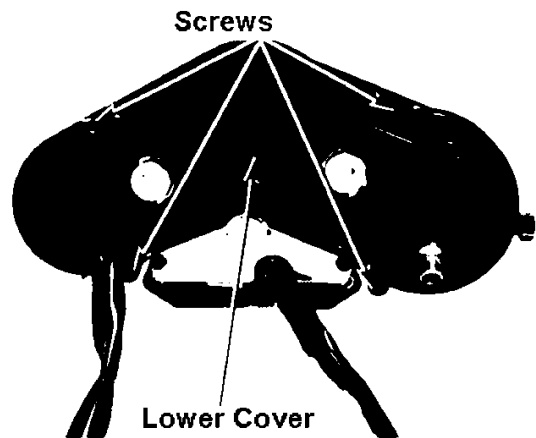

Remove two screws and detach the sub fuse holder.

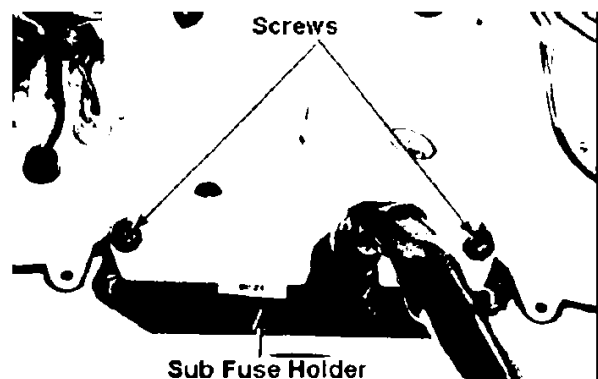

Remove two screws and detach the instrument upper cover.

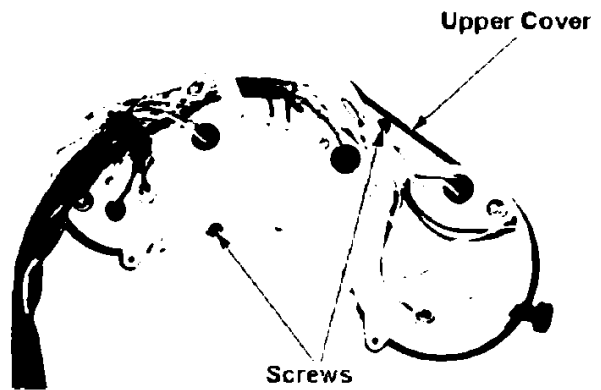

Detach connectors, bulb socket, trip meter reset knob and individual instruments attachment screws and separate the instruments.

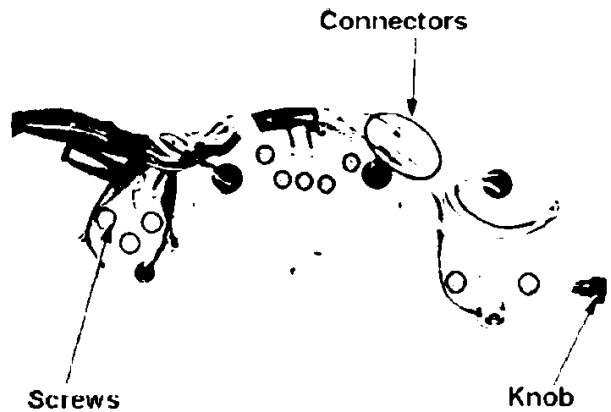

**Assembly / installation**

Reverse the removal / disassembly procedure.  
**Torque: Instruments – 0.8 ~ 1.2kg-m**

- Properly apply instrument wire harness (1-21).
- Connect the wires correctly to terminals check for security.

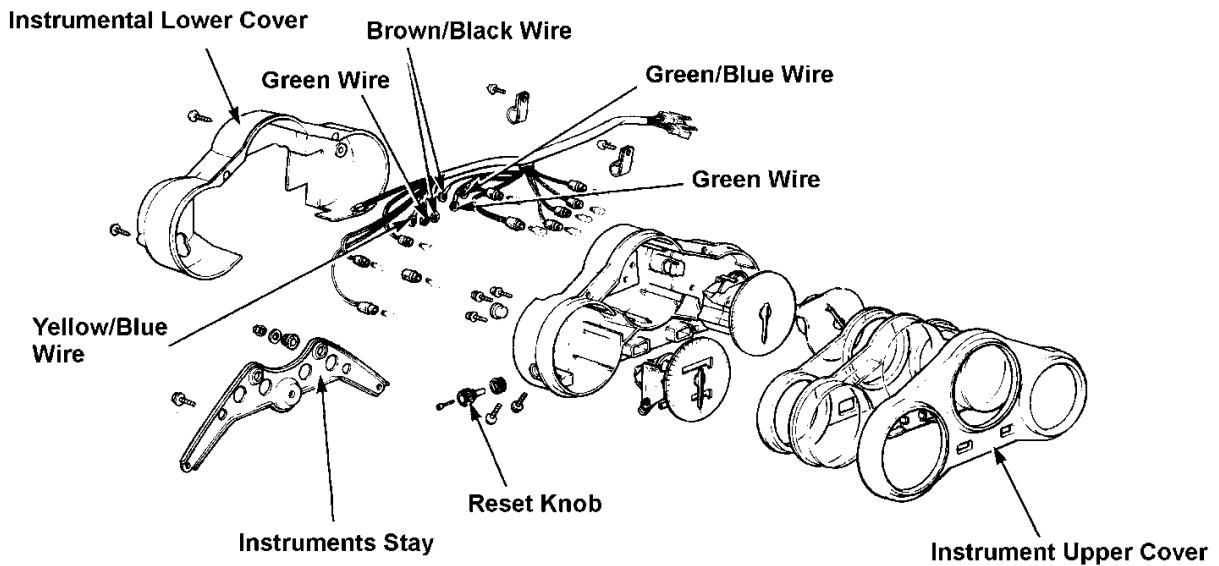

**Bulb replacement**

Remove instruments from the instrument stay and detach the lower cover (20-3).  
Remove a bulb socket and replace the bulbs.

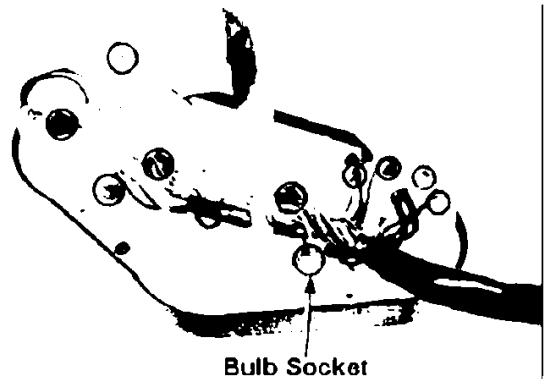

**Main switch**

**Inspection**

Remove the fuel tank and disconnect the coupler for the main switch.

Conduction should exist between O-O symbols.

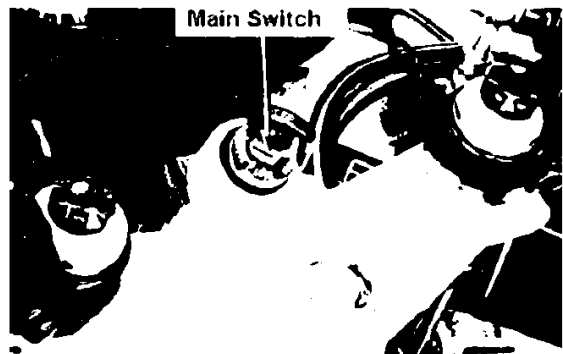

	BAT 1	IG	FAN	TL#1	TL#2	PA
	Red	Red / Black	Blue / Amber	Brown / White	Brown	Yellow /Black
ON	O —	— O —	— O	O —	— O	
OFF						
P.LOCK	O —					— O
LOCK						

**Removal**

Remove the fuel tank and disconnect the main switch GP coupler.  
Remove two main switch attachment bolts and remove the main switch.

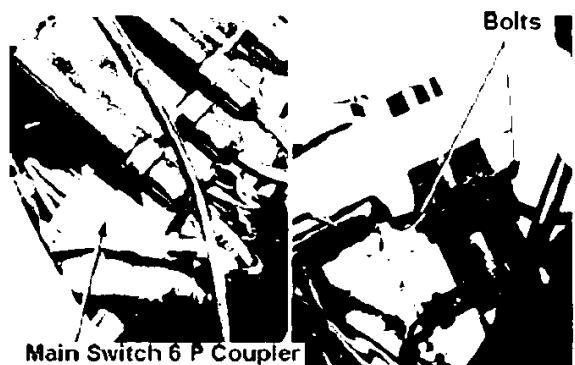

**Disassembly**

Cut the band and remove three screws.  
Detach the switch from the switch cylinder.

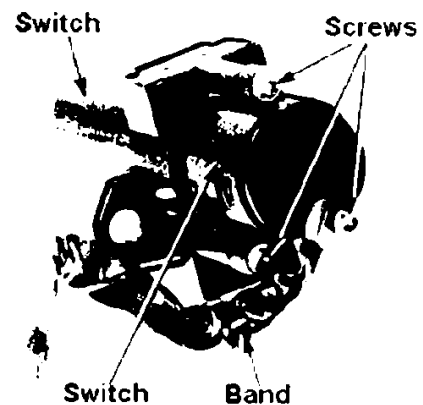

# CBR250R,RR 20. Light, Instruments & Switches

## Assembly

Align the cylinder shaft to the slit on the switch and attach it.

Tighten three screws and clamp it with the band.

Firmly clamp it so as not to loosen the wires.

Cut off unnecessary band.

Check the switch conduction after assembly

## Installation

Reverse the removal procedure.

**Torque: Ignition switch attachment bolt:**

**2.5 ~ 3.0kg-m**

After installation, check the operation of the switch.

## Steering handle switches

Remove fuel tank (4-3).

Disconnect #1, #4 ignition coil attachment bolts and terminals (18-4).

Remove harness for each switch and disconnect couplers.

Check conduction for 0-0 section

### <Kill Switch>

	IG	BAT 2
	Black/White	Black
OFF		
RUN	○	○

### <Starter Switch>

	BAT 2	ST
	Black	Yellow/Red
FREE		
PUSH	○	○

### <Lighting Switch>

	BAT4	TL	BAT5	HL
	Brown/Blue	Brown/White	Black/Red	Blue/White
•				
P	○	○		
H	○	○	○	○

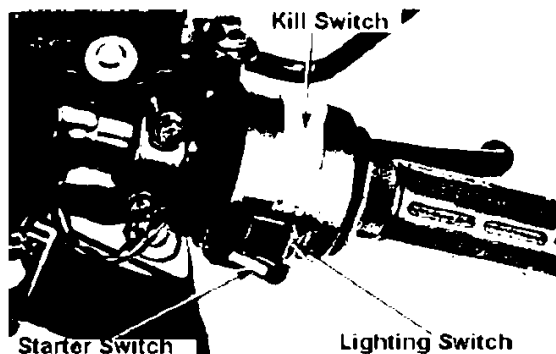
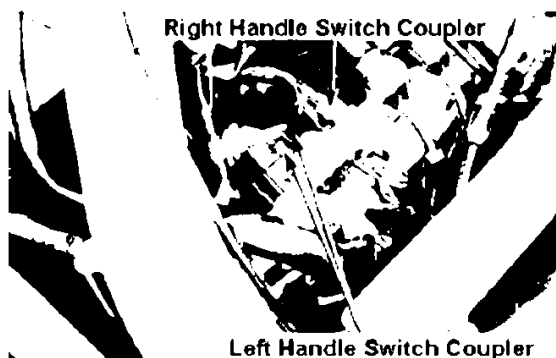
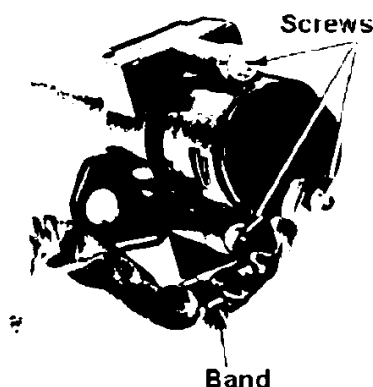
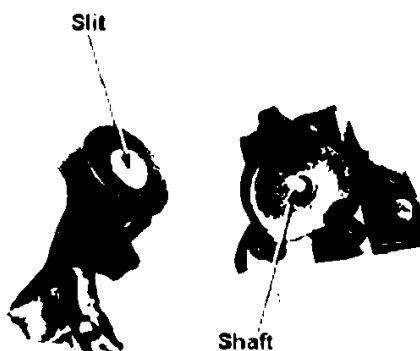

**<Passing Switch>**

	BAT3	HI
	White/Green	Blue
FREE		
PUSH	○	○

**<Horn Switch>**

	BAT3	HO
	White/Green	Light Green
FREE		
PUSH	○	○

	HL	LO	HI
	Blue/White	White	Blue
Lo	○	○	
(N)	○	○	○
Hi	○		○

	W	R	L	TL#1	PR	PL
	Grey	sky-blue	Amber	Brown	Sky Blue / White	Amber / White
R	○	○		○		○
N				○	○	○
L	○		○	○	○	

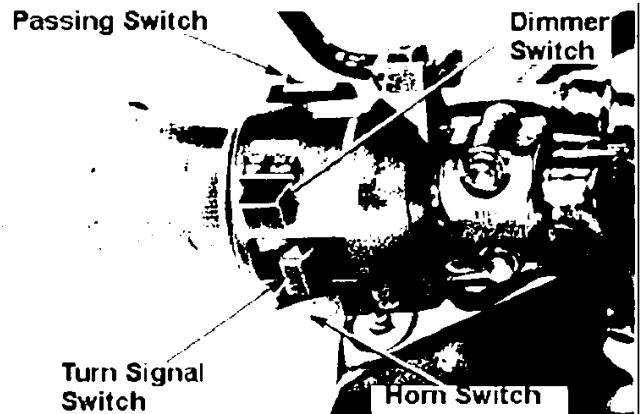

**Oil Pressure Switch**

Turn the main switch ON and check the illumination of the oil pressure warning light on the indicator panel.

If it does not illuminate, disconnect oil pressure switch wires and earth the wire.

Turn the main switch ON and check the illumination.

If it does not illuminate, inspect the warning light for it's bulb, it's wire harness connection and the sub fuse.

Start the engine and check the warning light is OFF. If it is ON, measure oil pressure (3-4).

If the oil pressure is normal, replace with new oil pressure switch (3-4).

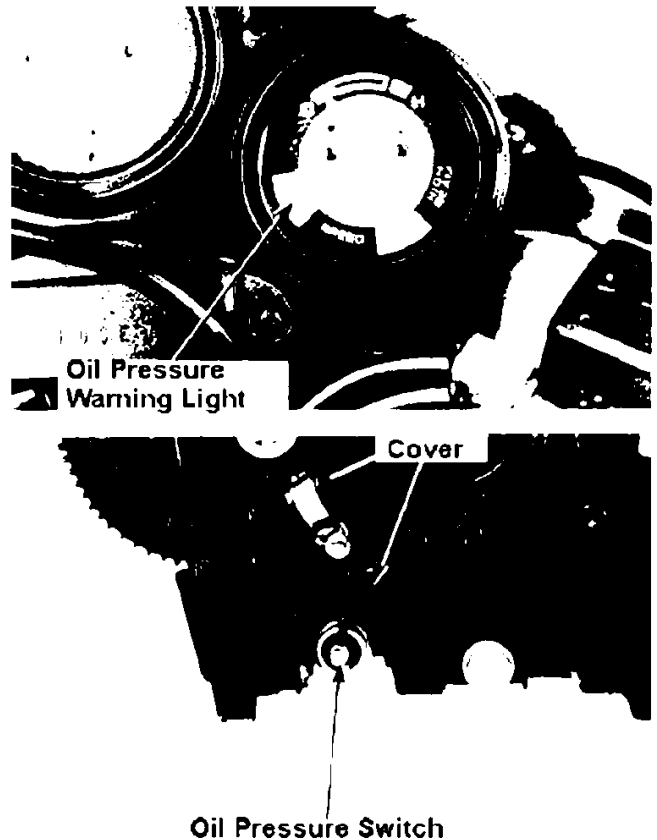

**Water temperature gauge**

Remove the side cowl.  
 Disconnect the connector from thermo-sensor on the thermostat case.  
 Earth the connect terminal by using a jumper wire.  
 Turn the main switch ON and check the water temperature gauge fully deflects to its side.  
 Inspect the wire harness if it doesn't deflect.  
 Replace the gauge if wire harness is ok (20-4).

Do not earth the thermo-sensor for more than five seconds.

**Tachometer**

Inspect the following points if the tachometer is faulty.  
 Inspect No.1 coil for proper spark.  
 If there is no spark on the spark plug, inspect the ignition system (18-3).  
 If spark is ok, remove the fairing and the fuel tank.  
 Disconnect the 4P mini coupler for the instrument, Yellow/Blue wire for the ignition coil and spark unit 4P mini coupler and check the conduction of Yellow/Blue wire.

Conduction → replace the tachometer  
 No conduction → replace the wire harness

**Cooling fan switch**

The cooling fan activates when the cooling fan switch detects the radiator water temperature very high.  
 Run the engine until the radiator water temperature reaches 98°C ~ 102°C and check the operation of the fan motor.  
 Check the motor stops when the temperature comes down to 93 ~ 97°C.

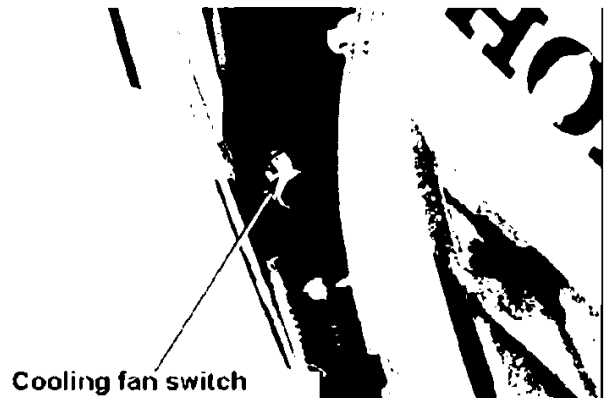
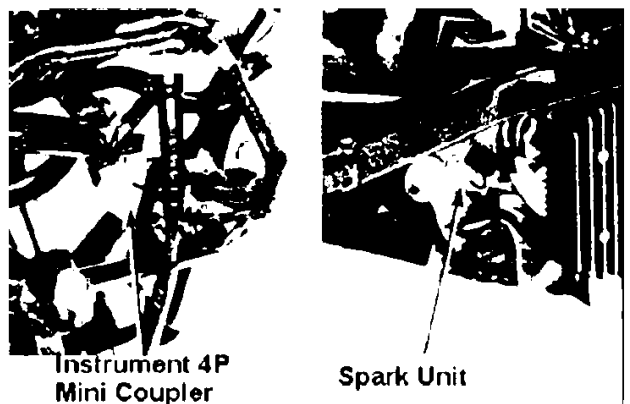
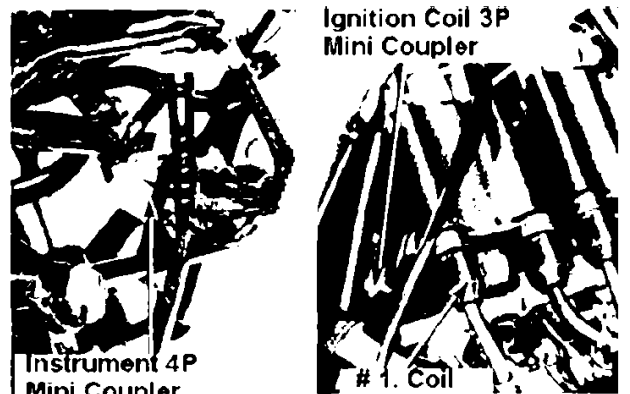
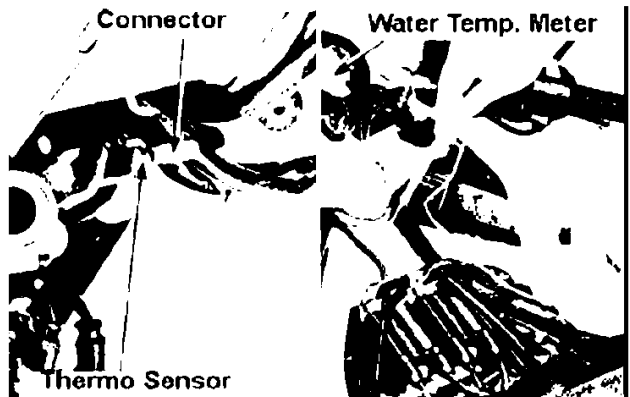



If the fan motor does not work, remove the connector from the cooling fan switch and earth the connector by using jumper leads.

Turn the main switch ON. If the fan motor works, the cooling fan switch is faulty.

If the fan motor does not work, measure voltage between the connector terminal and ground earth.

If the voltage is zero, inspect the following items:

- sub fuse
- looseness of terminal / connector
- wire harness open / short circuit.

If sufficient voltage exists, the fan motor is faulty.

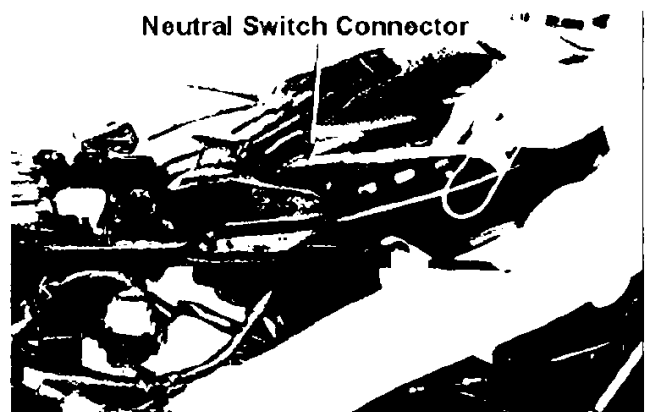
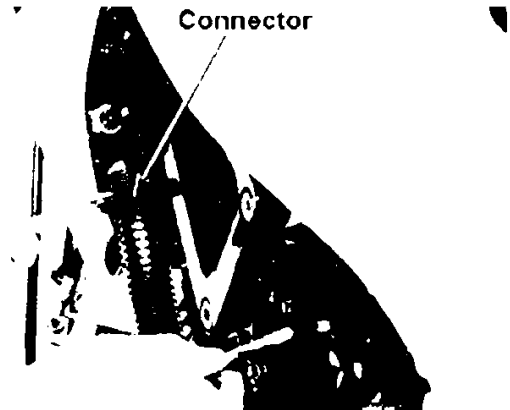

**Neutral switch**

Remove the fuel tank (4-3)

Disconnect the neutral switch connector and inspect conduction between light green/red wire and ground earth.

Conduction only exists when the transmission is set to neutral.

**Brake light switch**

**Front**

Disconnect the brake light switch connector. Inspect the conduction by operating the brake lever.

- Lever pulled:           conduction
- Lever released:       no conduction

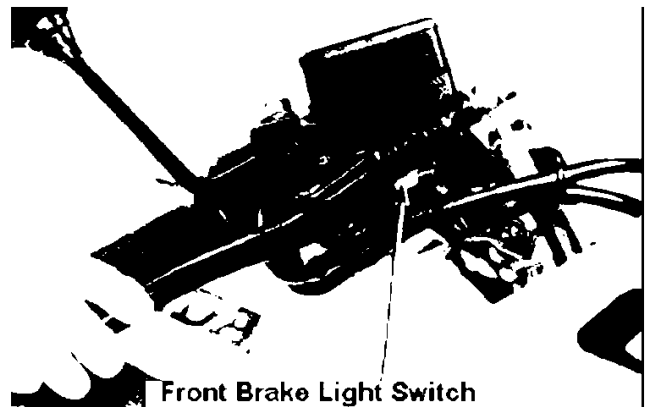

**Rear**

Remove the rear side cover and disconnect the rear brake light switch coupler. Inspect the conduction by operating the brake pedal.

- Pedal pushed in:       conduction
- Pedal released:       no conduction

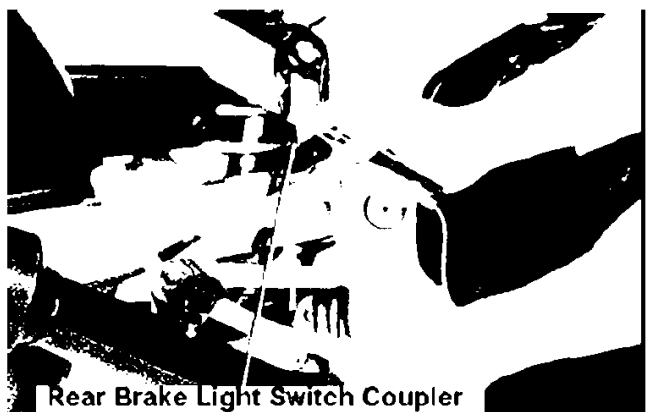

## Clutch switch

Disconnect the clutch switch connector.  
Operate the clutch switch and check  
conduction between terminals.

Lever pulled:            conduction  
Lever released:        no conduction

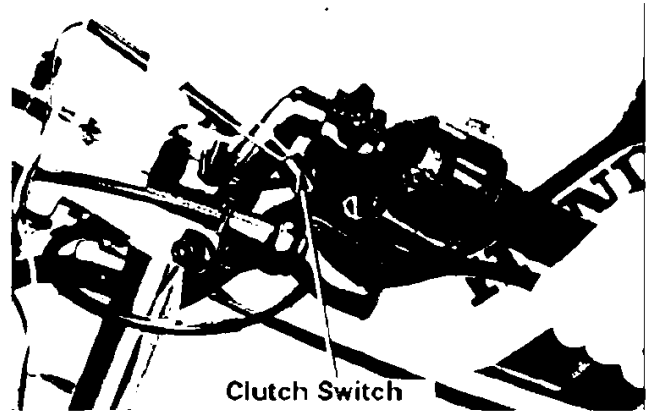

## Horn

Disconnect wires from the horn.  
Connect a 12V battery directly to the horn.  
The horn should work.

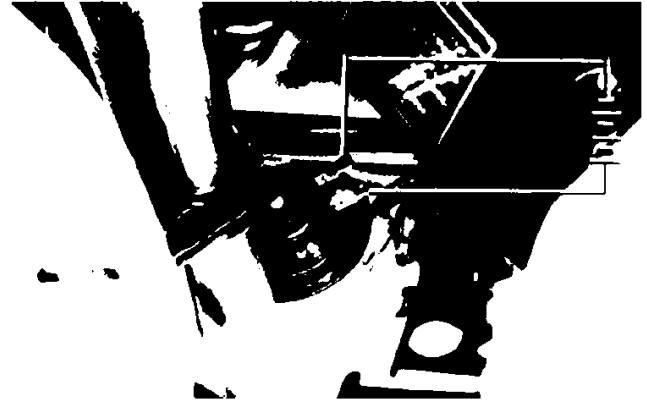

**TABLE OF CONTENTS**

<b>Service Information:.....</b>	<b>21 - 2</b>
<b>Inspection:.....</b>	<b>21 - 6</b>
<b>Fuel System:.....</b>	<b>21 - 12</b>
<b>Cooling System:.....</b>	<b>21 - 13</b>
<b>Engine Mount / Dismount:.....</b>	<b>21 - 13</b>
<b>Cylinder Head, Valve:.....</b>	<b>21 - 13</b>
<b>Cylinder, Piston and Crankshaft:.....</b>	<b>21 - 18</b>
<b>Clutch:.....</b>	<b>21 - 20</b>
<b>Change Cover attachment/detachment:.....</b>	<b>21 - 20</b>
<b>Front Wheel, Suspension and steering:.....</b>	<b>21 - 21</b>
<b>Rear wheel and Suspension:.....</b>	<b>21 - 24</b>
<b>Brake System:.....</b>	<b>21 - 31</b>
<b>Seat Cowl:.....</b>	<b>21 - 41</b>
<b>Sub-Frame:.....</b>	<b>.21 - 43</b>

## Service Information

### Specifications

Thick-lined parts differ from CBR250FOUR

Name		MC17		
Length		2.000m		
Width		0.680m		
Height		1.120m		
Wheelbase		1.365m		
Powerplant		MC14E		
Displacement		0.249 l		
Type of fuel		Unleaded Gasoline (petrol)		
Weight	Front	78kg		
	Rear	77kg		
	Total	155kg		
Max capacity		2		
Max Weight	Front	98kg		
	Rear	167kg		
	Total	265kg		
Tyre	Front	100 80-17 52H		
	Rear	130 70-17 62H		
Minimum clearance		0.140m		
Performance	Stop distance (Initial speed)		14.0m 50km/h	
	Min turning radius		2.7m	
Starter		Self start		
Type		Gasoline – 4 cycle		
Cylinders		Direct four abreast		
Combustion chamber		Pent Roof type		
Valve system		Gear driven inlet 2 Valve exhaust 2 Valve		
Bore x stroke		48.5x33.8mm		
Compression ratio		11.0		
Compression pressure		13.0kg cm <sup>2</sup> - 400rpm		
Max. output power		45PS 15,000rpm		
Max. torque		2.6kg-m 10,500rpm		
Power plant	Valve Operation	Inlet	Open	18° BTDC 1mm lifted
			Close	34° ABDC 1mm lifted
		exhaust	Open	36° BBDC 1mm lifted
			close	11° ATDC 1mm lifted
	Valve clearance		Inlet	0.66mm (cool)
		exhaust	0.23mm (cool)	
Unloaded rev.		1,00rpm		
Lubrication	Type		Compress-spray type	
	Pump type		Trocooid type	
	Filter type		Total flow, filter net and paper	
	Oil capacity		2.7 l	
Cooling system		Water cooled		

Fuel system	Air filter		Filter paper type	
	Fuel tank capacity		14.0l	
	Carburetor	Type		VG03
Valve diameter		30mm		
Venturi diameter		27mm		
Electrical system	Type		Full transistor, Battery ignited	
	Timing		20° BTDC/1500rpm	
	Spark Plug	NGK	C8EH-9 C9EH-9	
		ND	U24FE9, U27FE9	
	Clearance		0.8 – 0.9mm	
Battery Capacity		12V 8AH		
Transmission	Clutch Type		Multiple wet Coil spring	
	Operation		Mechanical	
	Motor to transaxle ratio		2.966	
	Gear ratio	Type		Constant mesh
		Gear Ratio	Low	2.733
			Second	2.000
			Third	1.590
			Fourth	1.333
			Fifth	1.153
	Sixth		1.035	
Front Reduction	NO. 1	Gear type	Chain	
		Reduction ratio	3.142	
	Castor		26° 00	
Wheels	Trail		97mm	
	Tyre air Pressure	Front	2.00kg/cm <sup>2</sup>	
Rear		2.50kg/cm <sup>2</sup>		
Steering angle		34°		
		34°		
Brake system	Front	Hydraulic disk brake		
	Rear	Hydraulic disk brake		
Suspension	Front	Telescopic		
	Rear	Swing arm		
Frame type		Diamond		
Frame no.		JH2MC22UXXM000001~		
Engine no.		MC14E – 1000001~		

**Torque settings (amended parts only)**

**Engine**

Part		No.	Screw Dia (mm)	Torque (kg-m)	Notes
Crankcase bolt		10	10	2.1-2.4	Apply oil
Gear train holder bolt	8mm	2	8	1.8-2.2	
	7mm	2	7	2.2-2.5	
Cylinder head attachment bolt	7mm	5	7	2.2-2.5	Apply oil
	8mm	1	8	2.4-2.7	
	7mm 4cm outer side	4	7	1.7-2.1	

**Frame**

Part	No.	Screw Dia (mm)	Torque (kg-m)	Notes
Brake disk bolt	15	8	3.7-4.3	
Cushion arm pivot pinch bolt and nut	1	8	2.0-3.0	
Hanger pin	5	10	1.5-2.0	
Hanger pin plug	5	10	0.2-0.3	
Brake hose attachment bolt	6	10	2.5-3.5	
Rear master cylinder bolt	2	6	1.0-1.4	
Rear caliper attachment bolt	1	8	2.0-2.5	
Bleeder valve	3	7	0.4-0.7	
Fuel tank attachment bolt - 8mm 6mm	1	8	1.8-2.5	
	1	6		
Fairing	10	6	0.7-1.1	
Fairing inside cover	5	6	0.6-1.0	
Driven sprocket	6	8	3.4-3.8	Apply oil

**Exclusive Tools (Amended parts only)**

**New exclusive tools**

Tool name	Tool no.	Part
Valve guide driver	07HMD-KT70100	Valve guide replacement
Valve guide reamer	07HMH-KT70100	Valve guide cleaning and finishing

**Existing exclusive tools**

Bearing remover - Remover handle - - remover sliding weight	07936-3710300 07936-3710100 07741-0010201	Needle bearings on suspension linkage (except for the pivot bearing on a cushion arm with a rear fork), main shaft left bearing detachment.
Bearing remover (15mm) - remover ASSY (15mm) - - remover shaft (15mm) - remover head (15mm) - Remover sliding weight	07936-KC10000 07936-KC10500 07936-KC10100 07936-KC10200 07741-0010201	Rear fork right pivot bearing and a pivot bearing with a rear fork on a cushion arm.
Bearing driver attachment	07GMD-KV30100	Rear fork left pivot bearing attachment
Driver attachment (28x30)	07946-1870100  07946-1870100	Clutch lifter blade bearing installation Rear fork left pivot bearing detachment
Driver handle	07949-3710001	Rear fork left pivot bearing detachment

## Common Tools

Tool name	Tool No.	Application
Pilot (15mm)	07746-0040300	Front wheel bearing, rear fork right pivot bearing, pivot bearing on a cushion arm with a rear fork.
Pilot (17mm)	07746-0040400	Rear wheel, suspension linkage (except for a pivot bearing on a cushion arm with a rear fork), driven sprocket and main shaft left bearing.
Pilot (12mm)	07746-0040200	Clutch filter plate bearing
Rear cushion compressor or Shock absorber compressor - compressor screw ASSY	07959-3290001 07GME-0010000 07GME-0010100	Rear cushion disassembly/assembly

## Valve seat cutter

Tool name	Tool No.	Application
Cutter holder (3.5mm)	07HMH-KT70200	Attach a cutter and adjust the valve seat.

## Newly established tool

- **Wiring**

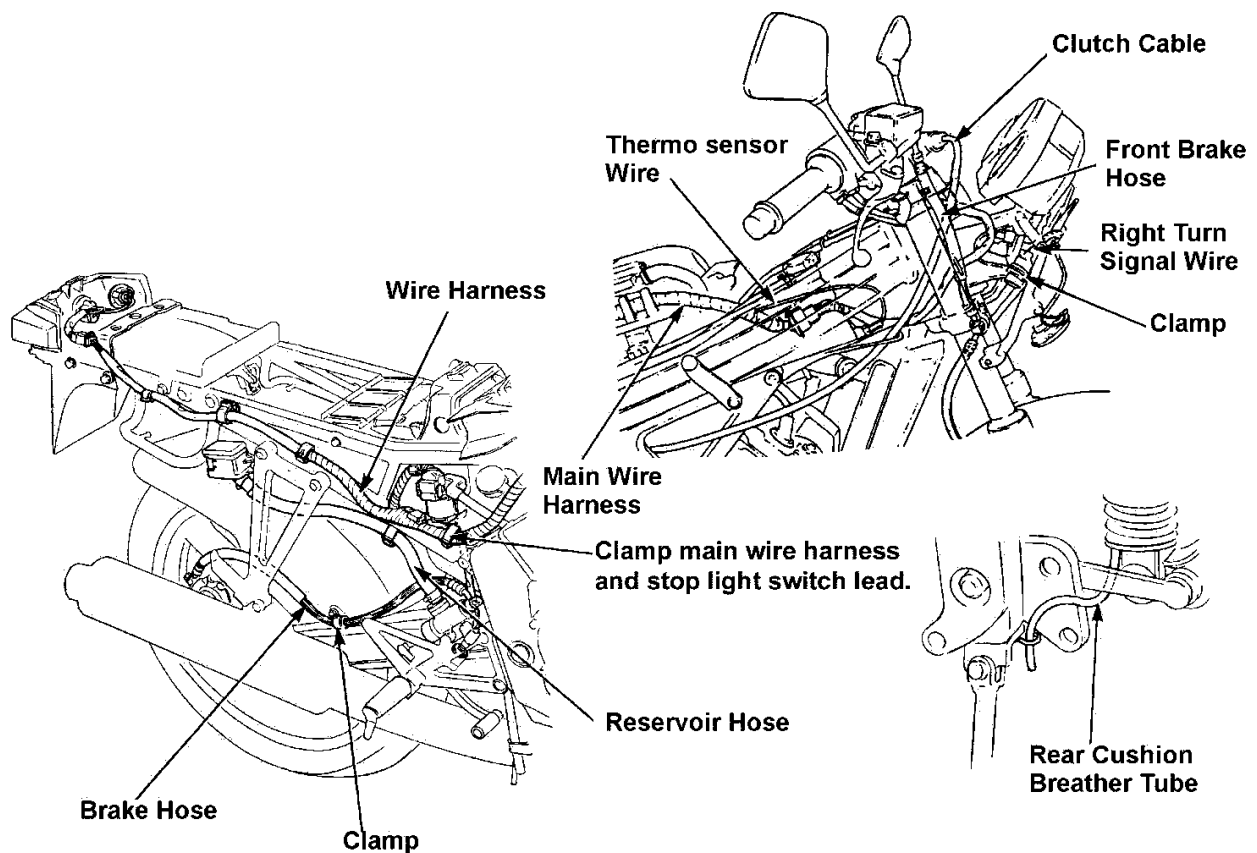

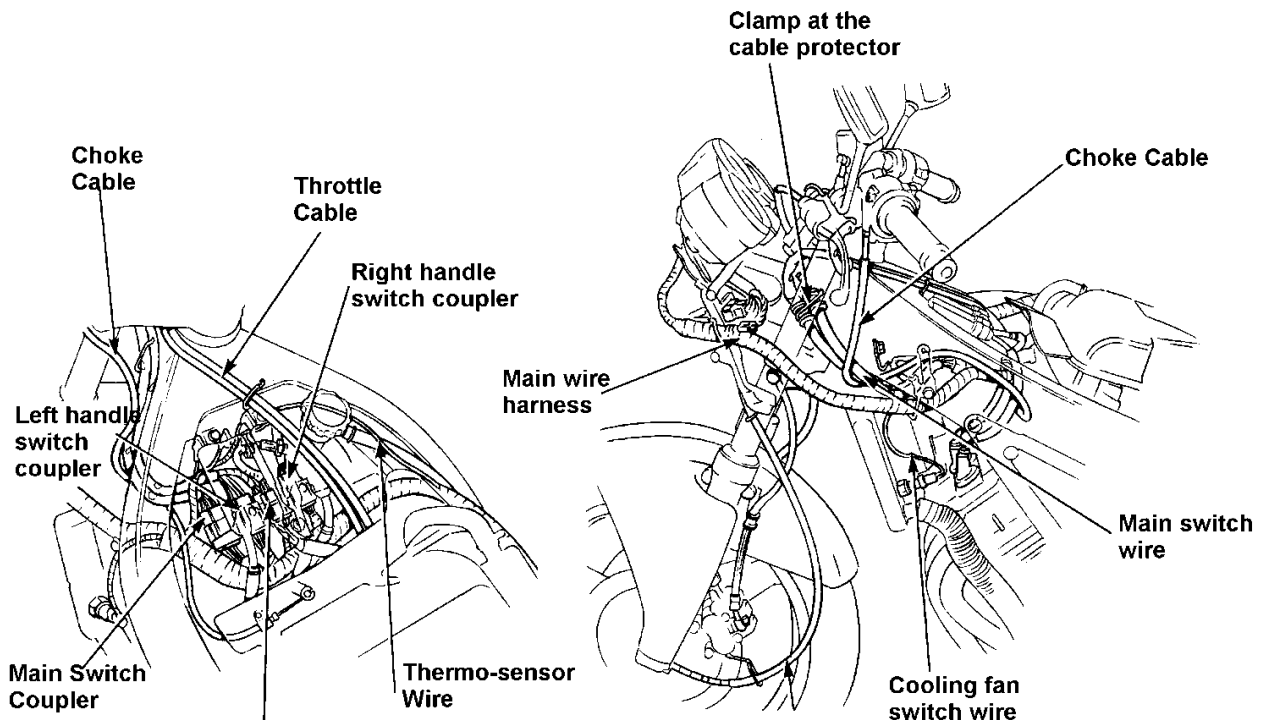

Top: Cooling fan coupler  
Bottom: Left handle switch coupler

Clamp main wire harness.  
Do not squash the clammer and leave 10mm of opened area

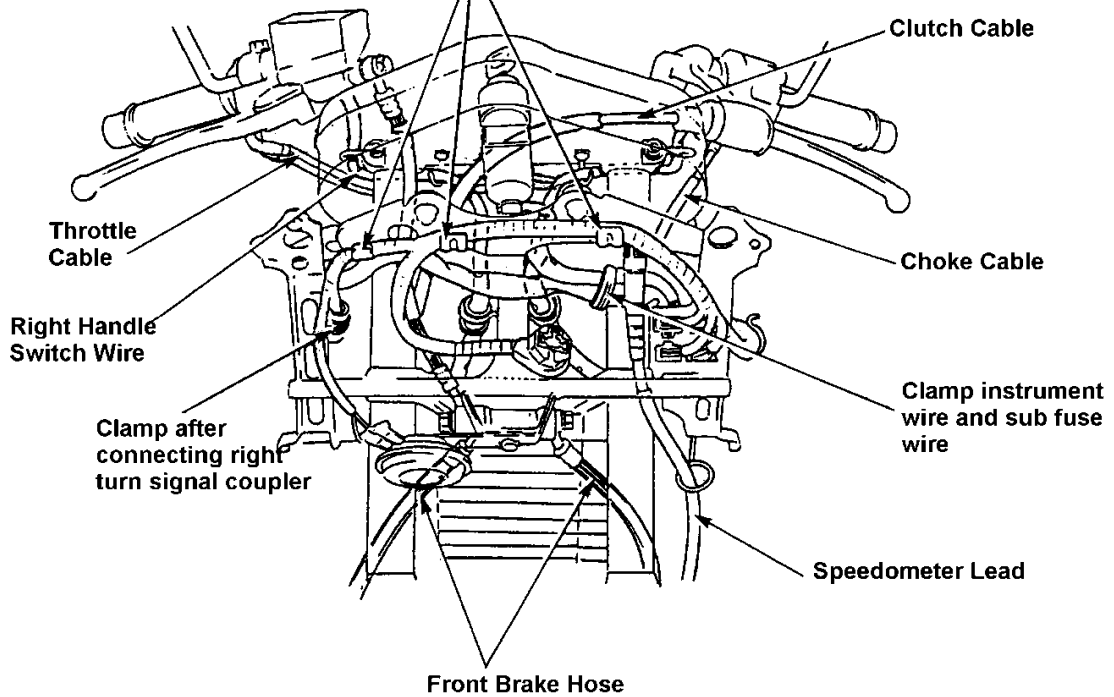

**Inspection / adjustment - Procedure**

1. Items for inspection include high speed driving inspection items.
2. (●) express compulsory inspection schedule and "O" mark is the recommendation of the manufacturer.
3. (●) indicates regular replacement.  
Replacement schedule is based on ordinary use. The schedule should be adjusted with operating condition.
4. "High speed" or "High speed driving" means driving at or above 80km/h.

Items to be serviced		Schedule				Notes			
		Before driving	1 month	Kilometres					
				6 month	12 month				
Steering	Steering head bearings	Free play / looseness				●			
		Smoothness					●		
	Steering wheel	Turning (steering) angle					●		
		Steering fork	Damage			●	●		
	Fork, spindle attachment				●	●		Steering stem	
	Fork, spindle bearing looseness						●		Steering stem
Brake pedal	Free play and clearance from ground when fully depressed.				●	●		Free play: Front brake lever edge 10~20mm Rear brake pedal 20~30mm	
	Pedal travelling length and effectiveness		●						
	Braking effectiveness			O	●	●			
Hose /pipe	Leak, damage and attachment			O	●	●			
	Brake hose replacement							● Every four years	
Braking System	Reservoir	Fluid level		●		●	●	Fluid level Front: at or above lowest level line Rear: between highest - lowest	
		Master cylinder, wheel cylinder, disk caliper	Function wear and damage					●	
	Cups for the master/wheel cylinder, dust seal, rubber parts for disk caliper replacement						● Biennial		
	Brake disk	Disk / pad clearance					●		
		Pad wear					●	Indicator	
		Disk wear / damage					●	Standard: Front 4.0mm Thickness: Rear 5.0mm Limitation: Front 3.5mm Rear 4.0mm	
fluid	Brake fluid damage						● Annual		
Wheels	Tyre air pressure		●	●	●	1 person 2 people Tyre	Normal High speed Normal Type	Unit: Front 2.00 Rear 2.00 2.00 100-80 17-52H	Kg / cm <sup>2</sup> Rear 2.25 2.25 2.50 130-70 17-62H



Items to be serviced		Schedule				Notes	
		Before driving	1 month	Kilometres			
				6 month	12 month		
Wheels	Crack and damage on tyres	●		●	●		
	Depth of tread and wear	●		●	●	Tread front 0.8mm - rear 0.8mm	
	Metal piece and other objects	●		●	●		
	Wheel nut and wheel bolt looseness			●	●	Axle nut, axle holder, front axle holder, torque 1.8~2.5kg-m front axle torque 5.5~6.5kg-m rear axle nut torque 8.0~10.0kg-m	
	Rim, side ring and wheel disk damage				●	Wheel rim deflection at rim edge Front wheel rim 2.0mm 2.0mm Rear wheel rim..... 2.0mm 2.0mm	
	Front wheel bearing looseness				●		
	Rear wheel bearing looseness				●		
Shock absorber Suspension arm spring - chassis	Damage				●	Cushion spring	
	Looseness on the jointed arm damage						
Shock absorber	Oil leak and damage				●		
	Attachment / looseness				●		
Transaxle	clutch	Lever free play			●	●	Clutch lever free play 10-20mm
		Operation			●	●	
	transmission	Oil leak and oil level			●	●	Oil level bar gauge (dipstick) between min-max.
		Control system looseness					●
Electrical system	Chain and Sprocket	Chain tension			●	●	When using sidestand, at the centre of front / rear sprocket: max deflection 15~25mm
		Sprocket attachment and wear					●
	Ignition	Spark plug			●	●	Plug gap: 0.8 – 0.9mm
	Battery	Terminal connection					
	Wiring	Joint looseness / damage					
Powerplant	Main component	Starting and sound			●	●	
		Low speed and acceleration			●	●	Idling rpm 1.500 ± 100rpm
		Exhaust gas			●	●	
		Air cleaner element replacement					20,000km every
		Valve clearance				●	Inlet (cool): 0.13 – 0.19mm Exhaust (cool): 0.20 – 0.26mm

Items to be serviced		Schedule				Notes		
		Before driving	1 month	Kilometres				
				6 month	12 month			
Power plant	Lubrication system	Oil dirty / quantity			●	●	Oil level Dipstick – between min - max	
		Oil leak			●	●		
		Oil quantity	●					
		Engine oil change						Initial 1.000km, every 6000km after that
		Oil filter						Initial 13.000km, every 12,000km after that
	Fuel system	Fuel leak			●	●		
		Carburetor linkage system				●		
		Throttle valve and choke valve				●		
		Fuel filter				●		
		Fuel quantity	●					
	Cooling system	Fuel hose replacement						★ Every four years
		Coolant level	●		●	●		Reservoir tank between min-max.
		Coolant leak	●			●		
		Radiator cap				●		0.95-1.25kg/cm <sup>2</sup> valve opening pressure
Coolant replacement							Biannual	
Exterior lights	Function			●	●			
	Illumination, dirt and damage	●						
Lock	Function				●			
Rear view mirror	Images	●				Only rearview mirrors		
Reflector, registration plate/plate holder	Dirt and damage	●						
Instruments	Function				●			
Exhaust pipe & muffler	Looseness of attachment damage				●			
	Muffler function				●			
Body	Looseness and damage				●			
Previously Detected defects	Inspect the corresponding part	●						
Other	Greasing and lubrication of chassis			●	●			

## Brake System

### Brake pedal height adjustment

Loosen the rear master cylinder push rod's lock nut and rotate the push rod to adjust the height of the brake pedal. Check the rear stoplight switch function after adjusting. Adjust if required (2-20).

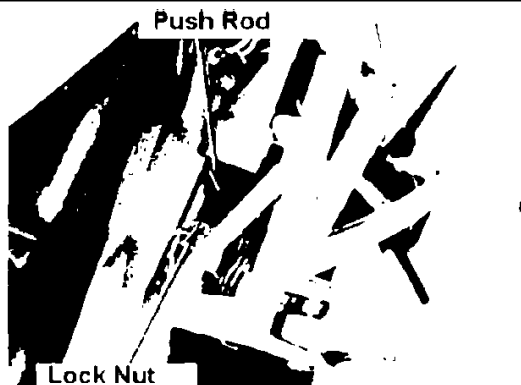

### Brake lever adjustment

By rotating the adjuster, the distance (A) from the grip to the edge of the brake lever can be adjusted.

Always align the symbol on the adjuster to the arrow symbol on the brake lever.

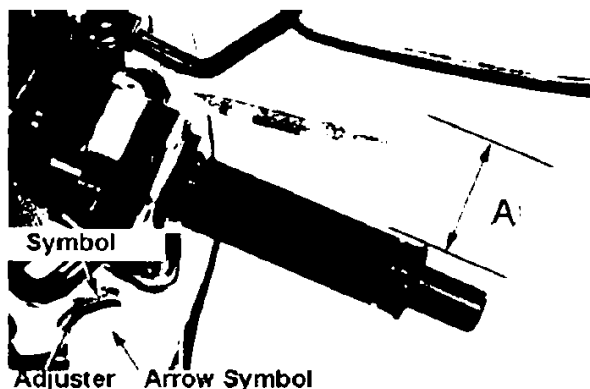

### Rear brake fluid level

Check the brake fluid level.  
Check for the fluid leak if the level is low.  
Remove the right side cover.  
Remove two reservoir cap attachments screws and remove the cap. Fill DOT 3 or DOT 4 standard brake fluid to the upper limit line.

- Do not mix different products of brake fluids.
- The top surface of the reservoir cap should be level when inspecting/refilling brake fluid.
- Keep the brake fluid away from dust/debris.
- Keep the fluid away from painted/plastic / rubber surfaces.

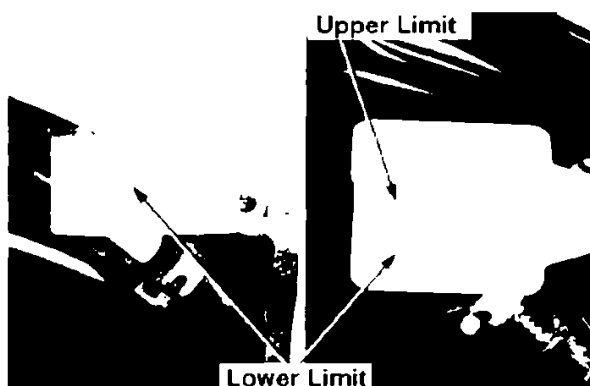

### Rear brake pad wear

Fully depress the brake pedal and inspect wear of inner / outer brake pads.  
Inspect the wear from back of the vehicle.  
Replace pads if the pad is worn to the maximum wear line (21-33)

- Replace pads in a set.



Inspect the contact surface of the brake disk for unusual wear and damage (21-35).

## Transaxle system Clutch

### Clutch lever free play

Inspect the free play of the clutch lever (2-7).

Remove the quick screw and detach the right maintenance cover boss from a lower fairing grommet and detach the right maintenance cover.

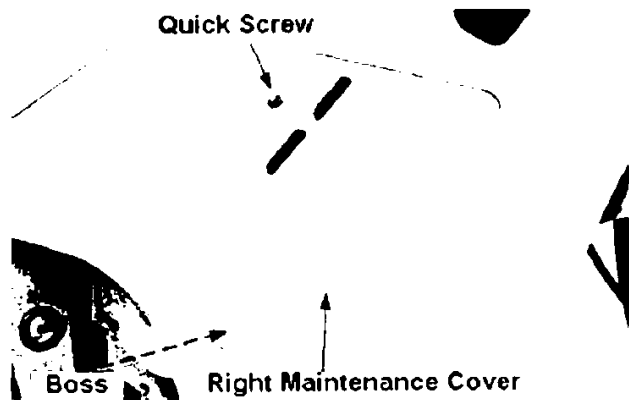

Major adjustments can be done by loosening the lock nut and rotating the adjust nut.

### Minor adjustments (2-7)

The following parts can be inspected by detaching the right maintenance cover.

- ignition timing (2-10)
- oil colour and quantity (2-15)

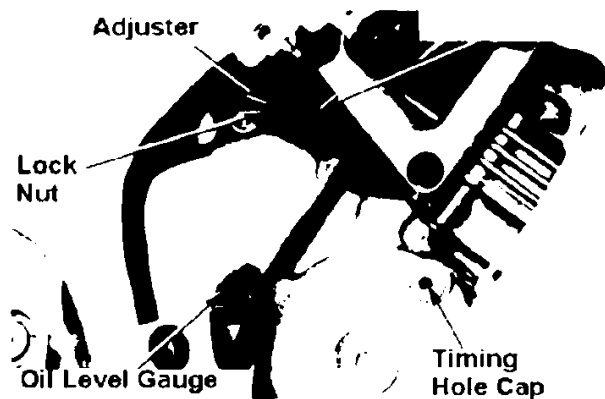

## Chain and sprocket

### Drive chain tension

Drive chain adjustment (2-8)

Replace the drive chain if the index marking on the rear axle spacer is aligned with the red label on rear fork.

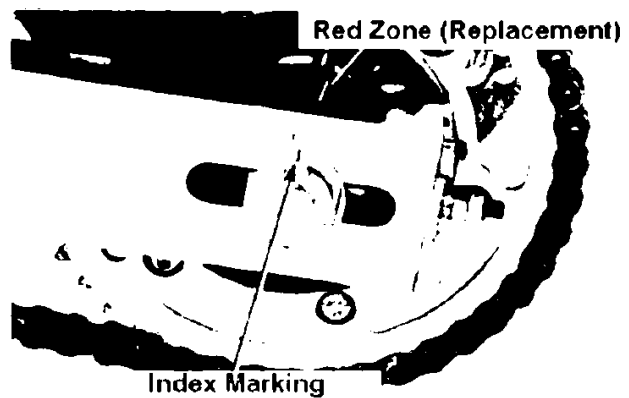

## Powerplant

### Main body

### Idle speed adjustment

Remove the quick screw and detach the left maintenance cover boss from the left lower fairing grommet and detach the left maintenance cover.

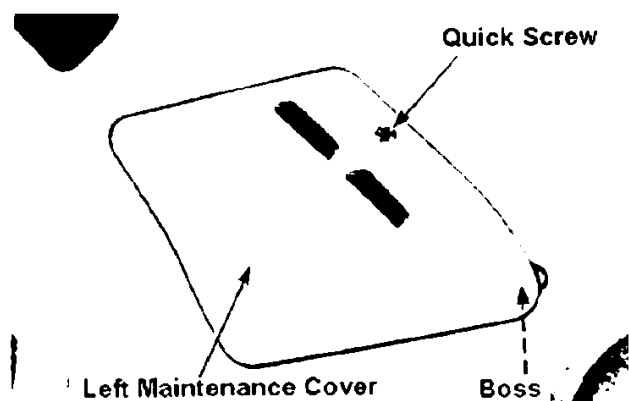

Adjust to standard idling rpm by rotating the throttle stop screw (2-10).

## Lubrication

### Engine oil drain

Warm up the engine before draining the oil.

Detach the oil level gauge.  
Remove the drain bolt and drain the engine oil.  
Turn the kill switch OFF and engage starter for a few seconds to drain remaining oil.  
Attach the drain bolt after cleaning.  
**Torque: 3.0 ~ 4.0kg-m**

Replace the sealing washer if damaged.

Fill with engine oil.

## Others

### Illumination

#### Front light

Remove upper fairing inside covers from both sides.

Adjust the vertical adjustment screws to (horizontal).

Adjust the (vertical / horizontal) beam path.

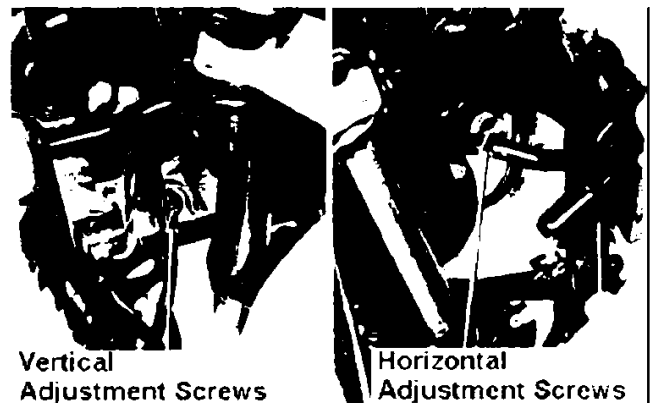
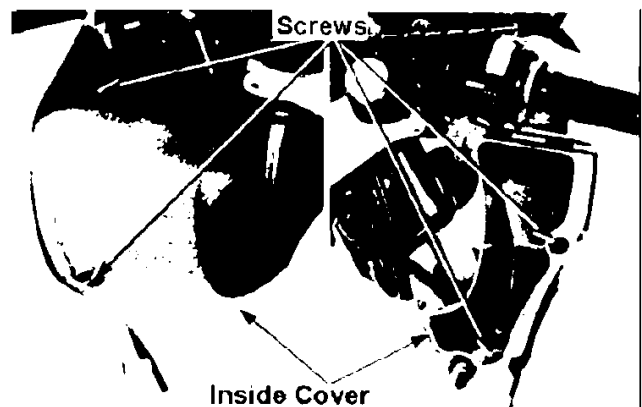
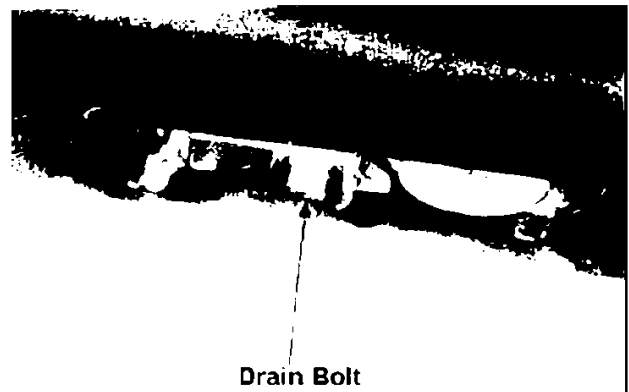
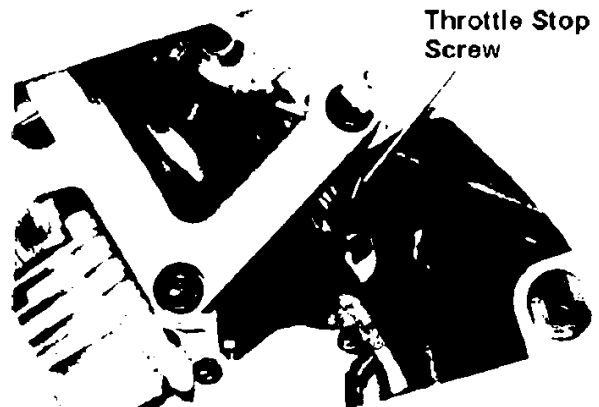



## Cooling system

### Service information

#### Standard

Thick lined cells differ from CBR250 four.

Item		Standard	Limitation
Radiator cap valve opening pressure		0.95-1.25kg/cm <sup>2</sup>	Replace if $\leq 0.95\text{kg/cm}^2$ Or $\geq 1.25\text{kg/cm}^2$
Thermostat valve opening temperature	Start opening	80-84°C	-
	Full open	95°C	-
	Full open lift	$\geq 8\text{mm}$	-
Coolant capacity		Total	Radiator approx 1100cc
		Capacity approx 1.300cc	Reservoir tank approx 200cc

## Engine mounting / dismounting

Remove the lower fairing (21-21)

Refer to Sec. 6 for engine attach/detachment.

Attach the lower fairing (21-23).

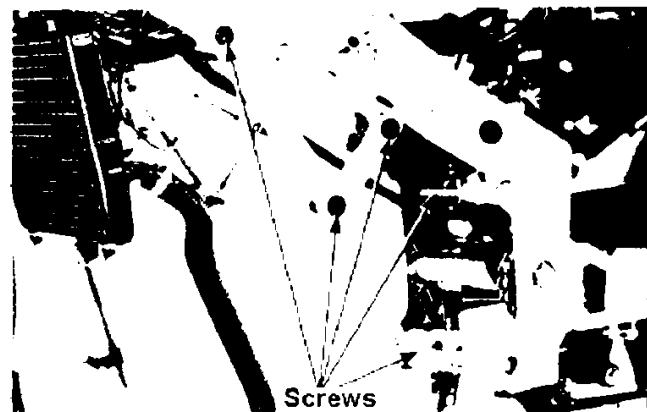

## Cylinder head and valve

### Service information

#### Standard

Thick lined cells differ from CBR250 four.

Item		Standard	Limitation	
Compression		13.0kg/cm <sup>2</sup> -400rpm	-	
Cam shaft	Cam lift	IN	29.00	
		EX	28.70	
	Oil clearance	1	0.015-0.057	0.06
		2	0.015-0.057	0.06
		3	0.025-0.067	0.07
		4	0.015-0.057	0.06
Deflection		-	0.05	
Valve spring	Relaxed length	38.58	37.6	
Valve, Valve guide	Valve stem Outer diameter	IN	3.478-3.492	3.473
		EX	3.460-3.475	3.445
	Valve stem Outer diameter	IN	3.500-3.512	3.565
		EX	3.500-3.512	3.565
	Stem / guide Clearance	IN	0.008-0.034	0.092
		EX	0.025-0.052	0.132
	Valve seat Contact width	IN	0.08	1.3
		EX	1.0	1.5
Valve lifter	Outer diameter	19.978-19.993	19.97	
Cylinder head	Deflection	-	0.05	
	Valve lifter contact part outer diameter	20.010-20.026	20.035	

## Cam gear train detachment

- Remove the lower fairing (21-21).
- Remove the cylinder head cover (7-3).
- Remove the cam shaft (7-3).
- Remove four bolts and detach the cam gear train.
- Remove the knock pin.

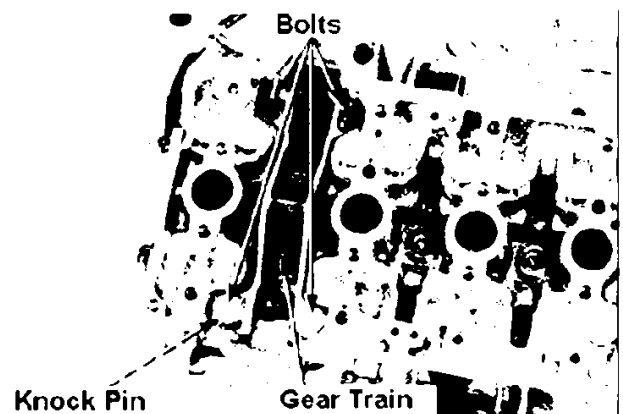

## Cylinder Head Detachment

Remove the following parts:

- fuel tank (4-3)
- aircleaner case (4-6)
- carburetor (4-8)
- exhaust pipe (16-2)
- cam shaft (7-3)
- cam gear train

Disconnect the oil path pipe and remove O-Ring, knock pin and oil orifice.

Remove bolts and remove water pipes and O-Rings.

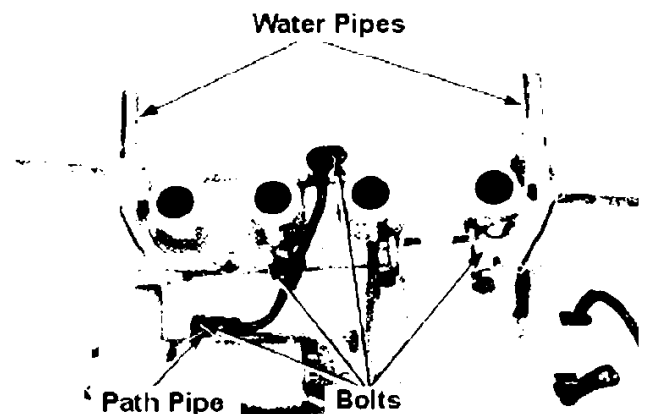

## Valve stem and valve guide inspection

Disassemble the cylinder heads (7-6).

Inspect each valve for bent, burn, damage and unequal wear of the stem edges.

Insert the valve to the guide and check the smooth operation.

Measure the stem outer diameter for each valve.

IN:  $\leq 3.473\text{mm}$  → Replace

EX:  $\cong 3.445\text{mm}$  → Replace

Apply the reamer through guides before the measurements to remove carbons.

**Exc. tools**

Valve guide reamer  
07HMH – KT70100

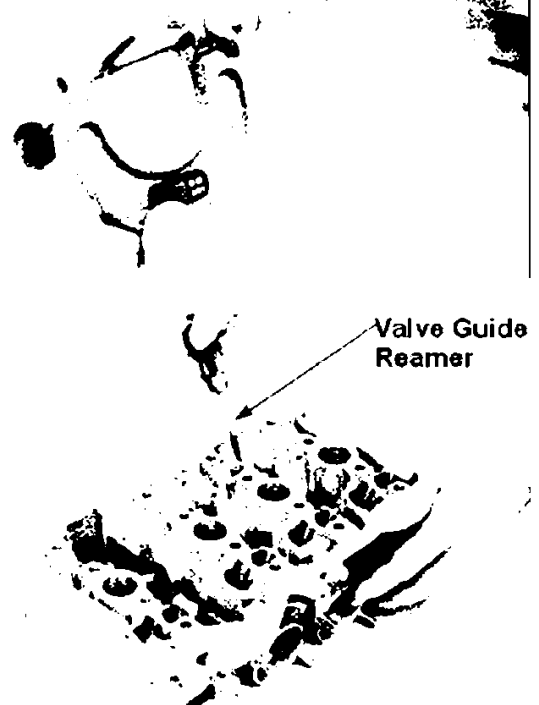



Measure inner diameter of each guide.  
 $\geq 3.565\text{mm}$  → Replace

Valve stem guide clearance is the difference between each guides inner diameter and corresponding valve stem outside diameter.

Valve stem guide clearance:

IN:  $\geq 0.092\text{mm}$  → Replace

EX:  $\geq 0.132\text{mm}$  → Replace

Calculate the clearance before replacing with a new guide. If the calculated valve falls within the limits, replace the guide.

If the clearance will be out of the limits even replacing with new guides, replace the valve as well.

- When the guide is replaced, adjust the valve seat (7-10).
- Use 07HMH-KT70200 cutter holder.

### Valve guide replacement

Gradually warm up the cylinder head to 100 - 150°C.

Do not use burners to avoid deformation of the cylinder heads.

Remove the valve guide.

Wear safety gloves.

Exercise caution not to damage the cylinder head.

Exc. Tool    Valve guide driver  
07HMD – KT70100

Install oversized valve guide.

Wear safety gloves.

Exc Tool    Valve guide driver  
07HMD – KT70100

After installing, finish the valve guide with a reamer.

Exc Tool    Valve guide driver  
07HMD – KT70100

Wash the cylinder head to remove debris. Inspect /adjust the valve seat contact (7-10).

Use a cutter holder 07HMH-KT70200

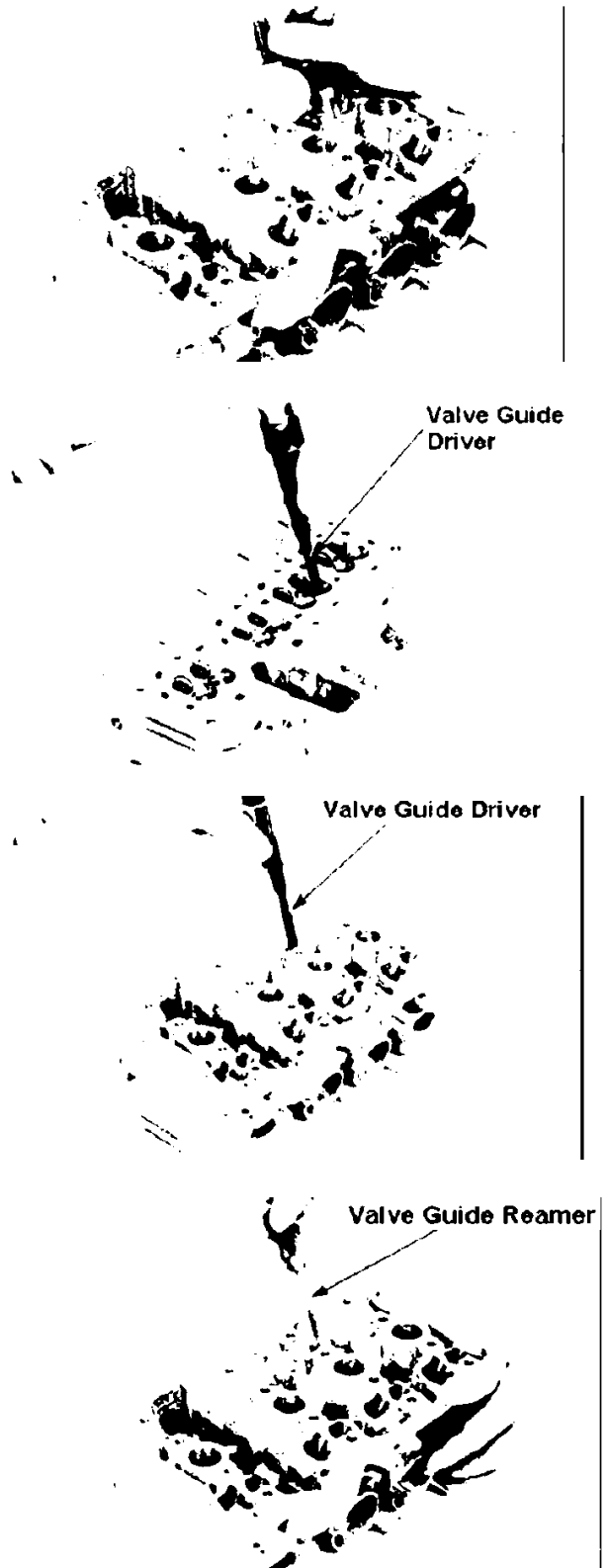

Use proper lubrication for reaming.

### Cylinder head attachment

Assemble the cylinder heads (7-15).  
 Attach knock pins, new gaskets (7-17).  
 Attach the cylinder heads.  
 Apply engine oil to the cylinder head attachment bolts and washers inside the engine. Set the bolts to the cylinder heads and tighten.

**Torque:** 1.7 ~ 2.1kg-m (7mm bolts: four on outside).  
 2.2 ~ 2.5kg-m (7mm bolts)  
 2.3 ~ 2.7kg-m (8mm bolts)

- Tighten the bolts from inner side towards outer side on opposite corners by repeating 2 ~ 3 times.
- Use of an exclusive tool is recommended to tighten dodecagon bolts.
- Exc. Bolt Tool – dodecagon socket wrench 07GMA-KT70100
- Do not use washer for two bolts underneath the cam gear train.

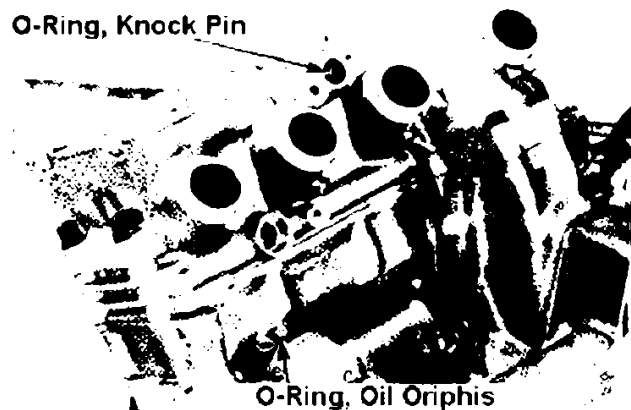
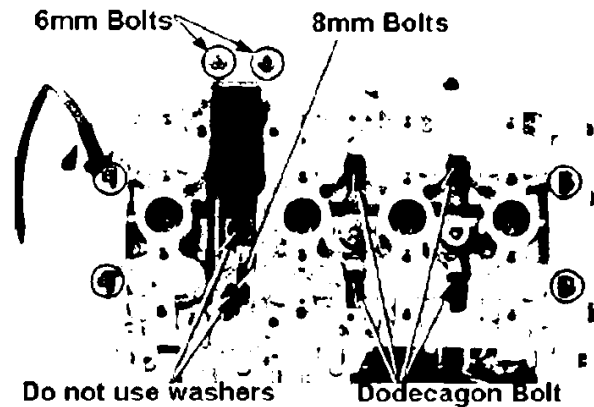

Inspect the oil orifice on the cylinder block for blockage and attach with the smaller hole facing upwards.

Apply engine oil to the new O-Ring and attach it.

Apply engine oil to the new O-Ring and attach it to the cylinder head.

Attach the knock pin.

Attach the new O-Ring to the water pipe.

Connect water pipes to the cylinder head.

Connect the oil path pipe.

Apply sealant to bolts on the cylinder block side and tighten the bolts.

Tighten the bolts on the cylinder head side.

Tighten the oil path pipe / water pipe bolts and water pipe bolts.

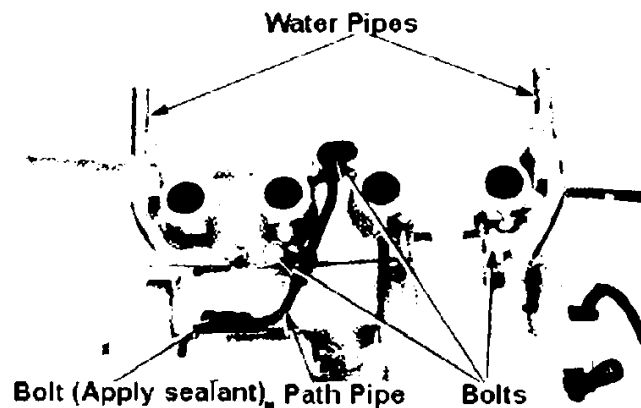

Attach the following parts:

- Exhaust pipe (16-2)
- Carburetor (4-18)
- Air cleaner case (4-7)
- Fuel tank (21-12)

## Cam gear train attachment

Attach the knock pin to a cylinder head.

There are two different types of 7mm bolts.

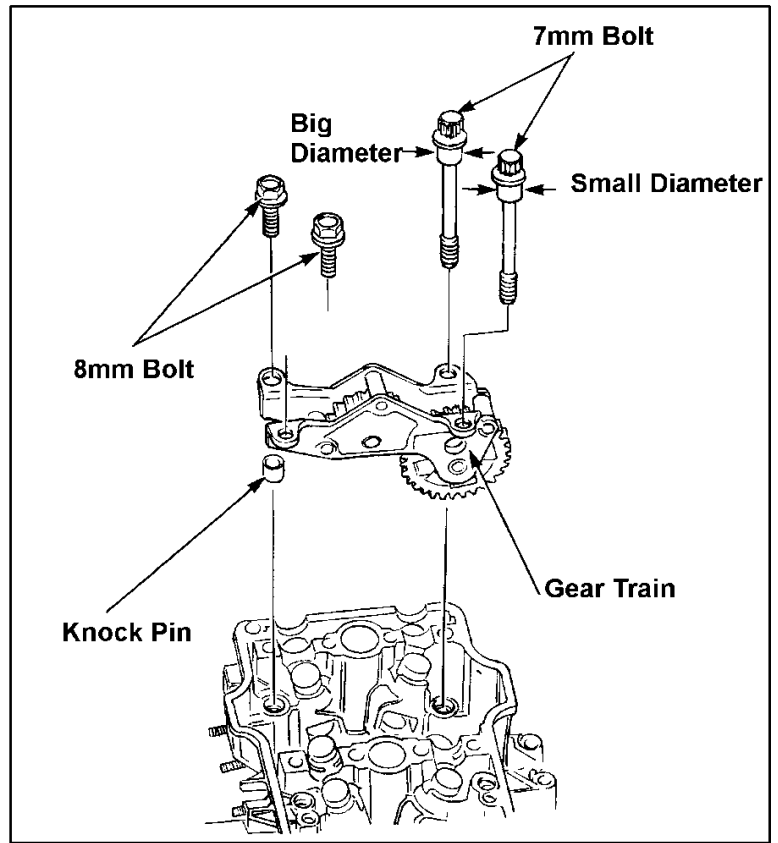

Attach the cam gear train and tighten the bolts.

Torque: 8mm bolts: 1.8 ~ 2.2kg-m

7mm bolts: 2.2 ~ 2.5kg-m

Attach the camshaft (7-19)

Attach the cylinder head cover (7-21)

Attach the lower cowling (21-23)

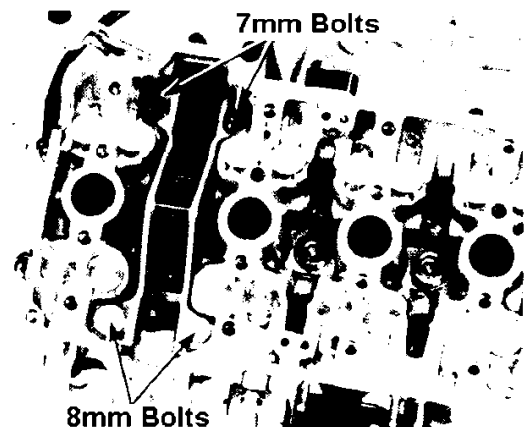

**Cylinder, piston and crankshaft**

**Service information**

**Standard**

**Thick lined cells differ from CBR250 four.**

Item		Standard	Limit	
Crankshaft, Conrod	Conrod bigend side clearance	0.05-0.2	0.30	
	Crankshaft deflection	-	0.05	
	Crank pin oil clearance	0.028-0.046	0.05	
	Main journal oil clearance	0.030-0.054	0.06	
Cylinder	Inner diameter	48.500-48.510	48.60	
	Top surface deformation	-	0.05	
	Deflection from true circle	-	0.005	
	Deflection from true cylinder	-	0.005	
Piston ring	Ring Clearance	Top	0.015-0.050	0.10
		Second	0.015-0.050	0.10
	Ring slit Gap	Top	0.1-0.25	0.45
		Second	0.1-0.3	0.50
		Oil (side rail)	0.2-0.8	1.00
Piston	Piston outside diameter	48.47-48.49	48.35	
	Piston / cylinder clearance	0.01-0.04	0.10	
	Piston pin hole diameter	13.002-13.008	13.02	
	Piston pin outside diameter	12.994-13.000	12.98	
	Piston / piston pin clearance	0.002-0.014	0.04	
	Conrod smaller edge inner diameter	13.016-13.034	13.05	
	Piston pin / conrod clearance	0.016-0.040	0.06	

**Crank pin bearing selection**

Separate the crankcase (8-2).

Remove the conrod (9-3).

Measure the oil clearance of the crank pin bearing (9-6).

If the oil clearance is beyond the limit, replace the bearing.

Select the bearing in accordance with the following procedure.

Record the conrod inner diameter code #.

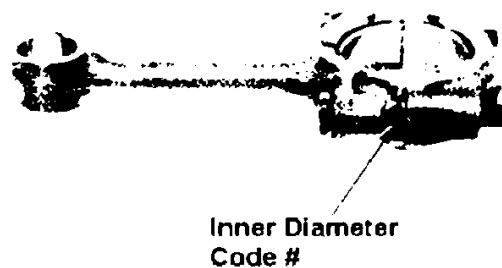

I, II or III on the conrod is the code #.

Record the outside diameter code # of the crankpins, or measure the outside diameter.

A, B or C on crank weights are the codes of the crankpins.



Outside Diameter Code

Find out the bearing colour from crankpin and conrod codes.

		1	2	3
		30.000 ~ 30.005mm	30.006 ~ 30.011mm	30.012 ~ 30.018mm
A	26.994 ~ 27.000mm	E (Yellow)	D (Green)	C (Brown)
B	26.988 ~ 26.993mm	D (Green)	C (Brown)	B (Black)
C	29.982 ~ 26.987mm	C (Brown)	B (Black)	A (Blue)

Bearing metal thickness:

- A (Blue) 1.499 ~ 1.502
- B (Black) 1.496 ~ 1.498
- C (Brown) 1.493 ~ 1.495
- D (Green) 1.490 ~ 1.492
- E (Yellow) 1.487 ~ 1.489

Colour Code

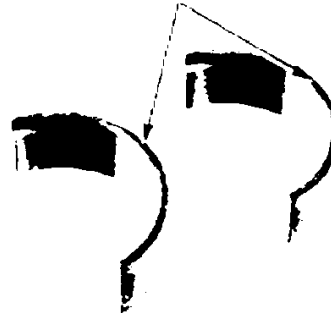

### Piston, conrod and crankshaft installation

Install pistons and conrods (9-10).  
Install the crankshaft (9-11).

Attach conrod bearing caps.

- Attach the cap to the same position it was detached.
- Inner diameter codes should face towards exhaust.

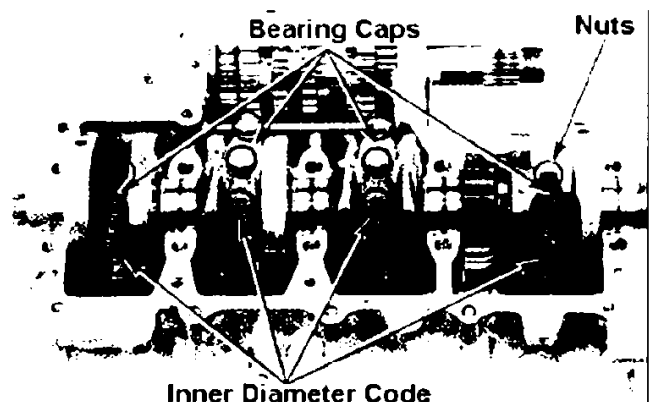

Inner Diameter Code

Tighten cap nuts (9-12).

**Clutch**

**Right crankcase cover detachment / attachment**

Drain engine oil (2-16).  
 Remove the left side cover.  
 Remove the regulate / rectifier.  
 Loosen the clutch cable, adjust nut and lock nut to disconnect the clutch cable.  
 Remove right crankcase cover attachment bolts and detach the right crankcase cover and the lower fairing stay.  
 Reverse the procedure for attachment.

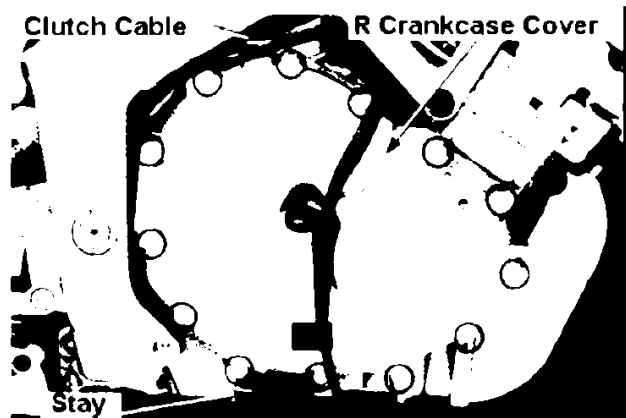

**Lifter plate bearing replacement**

Disconnect the clutch (10-5).  
 Inspect the lifter plate bearing (10-7) and replace as required.  
 Detach the bearing.  
 Attach the new bearing to the lifter plate, facing marked surface outwards.

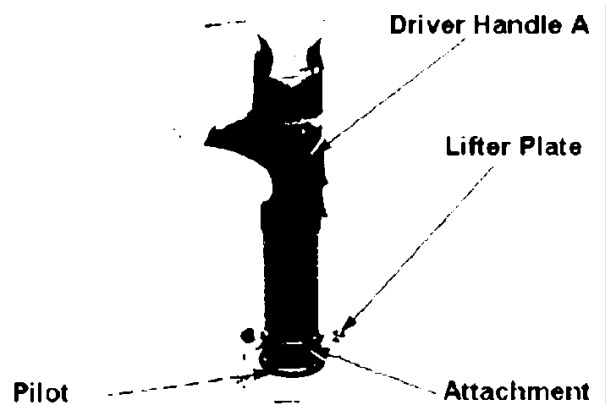

Exc. tool	Driver attachment (28 x 30mm) 07946 – 1870100
-----------	--

Common tools	Pilot (12mm)	07746-0040200
	Driver handle A	07749-0010000

Attach the clutch (10-10).  
 Attach the right crankcase cover.

**Change cover attachment / detachment**

Detach the left lower fairing (21-21).  
 Remove the drive sprocket cover and the change pedal.  
 Disconnect water pump (5-9).

The water pump can be disconnected without disconnecting the tubes.
---

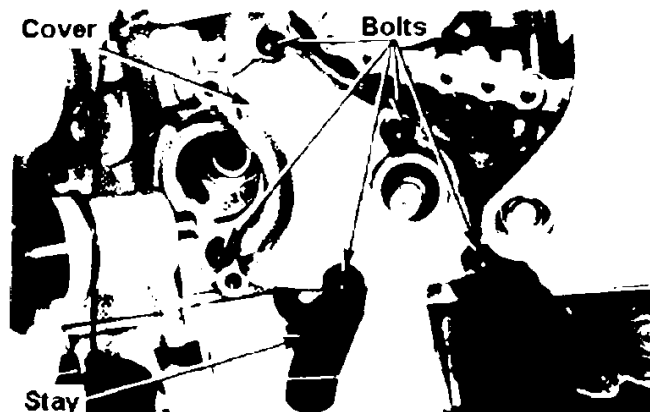

Remove five change cover attachment bolts.  
 By pushing the shift spindle in, detach the change cover and the lower fairing stay.  
 Remove the gasket and the knock pin.  
 Reverse the procedure for attachment.

**Front wheel, Suspension and Steering**

**Service information**

**Standard**

Thick lined cells differ from CBR250 four.

Item		Standard	Limitation
Front axle bent		-	0.2mm
Front wheel rim deflection	Radial	-	2.0mm
	Sideways	-	2.0mm
Front cushion spring relaxed length		396.6mm	388mm
Front fork pipe bent		-	0.2mm
Front fork oil capacity	Standard	302 ± 2.5cc	-
	Fully compressed	100mm	-

**Fairing**

**Detachment**

Disconnect the spring clip on the lower fairing.

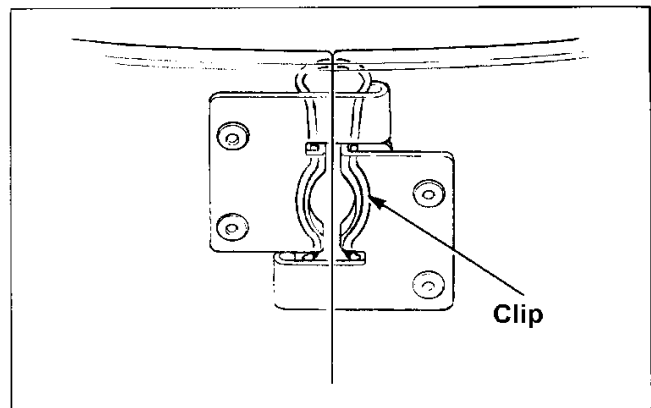

Remove the quick screw and detach the boss of the maintenance cover from the lower fairing grommet and detach the maintenance cover.

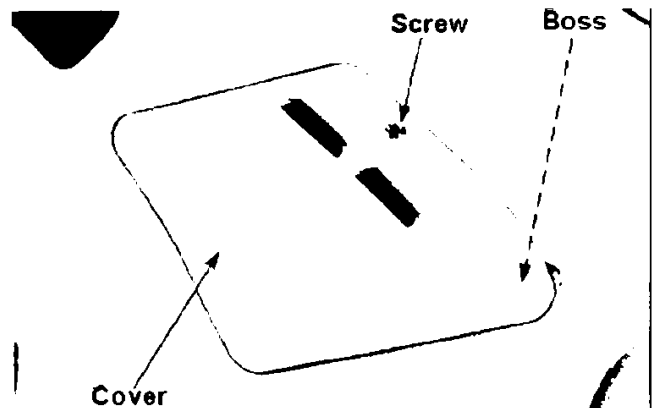

Remove screws

Detach the lower fairing boss from the frame grommet and detach the lower fairing.

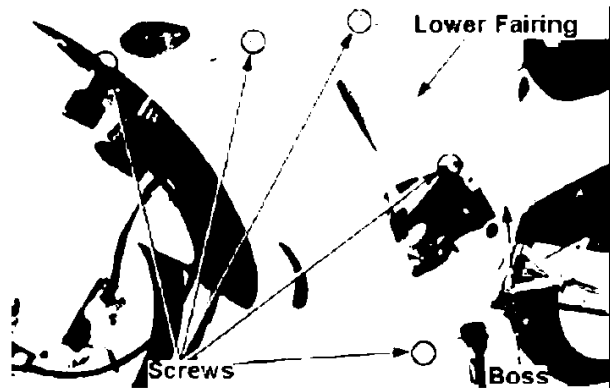

Remove screws and detach the upper fairing inside cover.

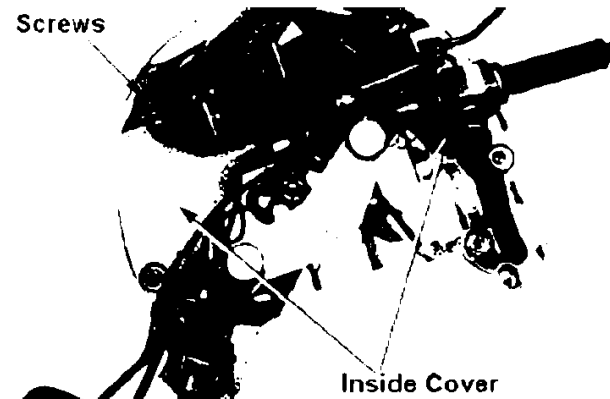

Disconnect the turn signal coupler.  
Disconnect the head coupler.  
Remove two bolts.

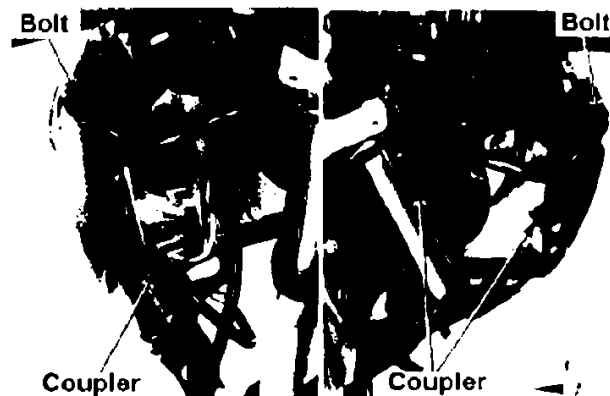

Remove two screws and detach the upper fairing.

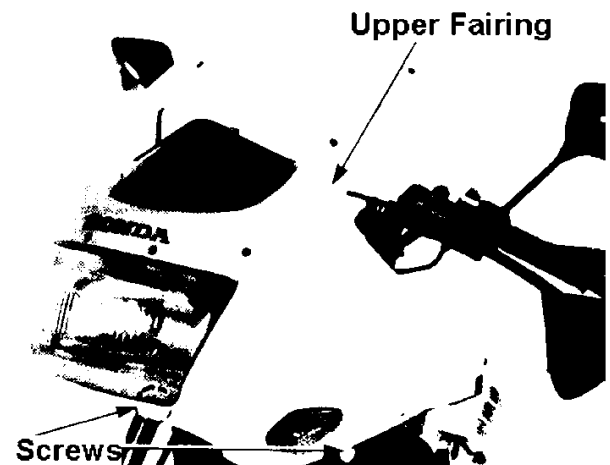



## Attachment

Reverse the detachment procedure.

Set the spring clip as shown in the figure below.

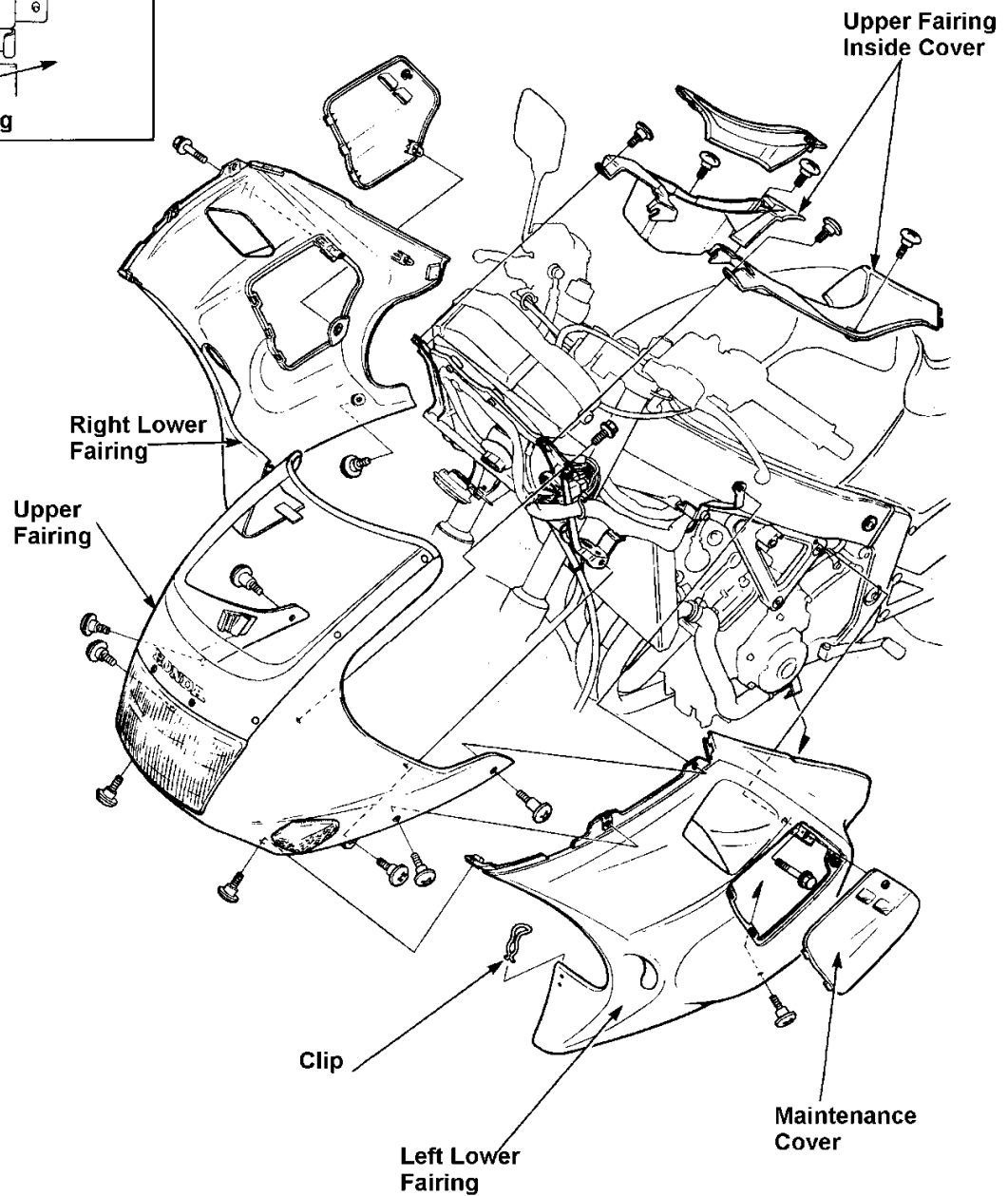
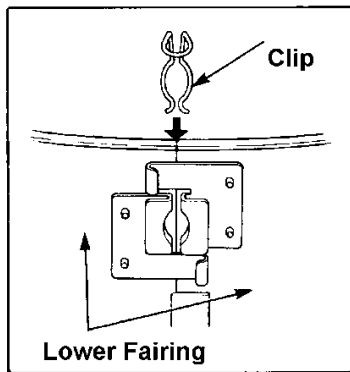

**21-23**

## Rear Wheel and Suspension Service information

### Standard

Thick lined cells differ from CBR250 four.

Item	Standard	Limitation
Rear axle bent	-	0.2mm
Rear wheel rim deflection	Radial	2.0mm
	Sideways	2.0mm
Rear cushion damper compression	30.8 – 36.8kg	24.6kg
Rear cushion spring attachment length (spring adjuster set to second)	166.9mm	-
Rear cushion spring relaxed length	178.8mm	175.0mm

### Rear wheel

#### Detachment / attachment

Support the frame and lift the rear wheel off the surface.  
Remove the axle nut and remove the axle shaft.  
Detach the rear wheel.  
Reverse the procedure for attachment.

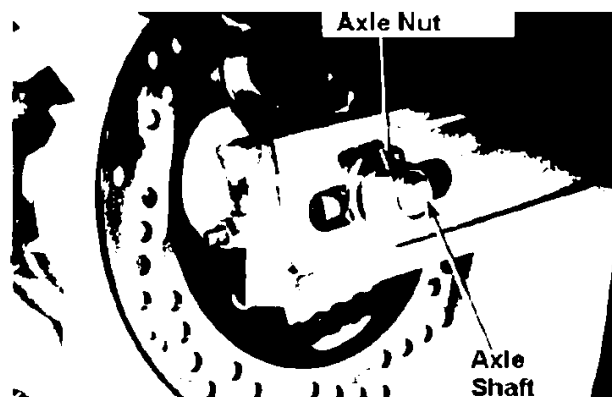

Exercise caution not to damage brake disk/pads when detaching / attaching the wheel.

#### Rear brake disk detachment

Remove the rear wheel.  
Detach the right side collar and adjust seal if necessary.  
Remove three bolts and detach the rear brake disk.

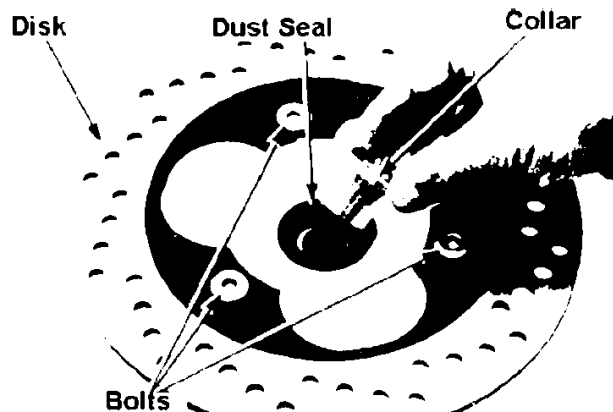

#### Rear brake disk attachment

Attach the brake disk and tighten three bolts.  
**Torque: 3.7 ~ 4.3kg-m**

If adjust seal was removed, replace with a new one and attach after applying grease to its lip.  
Attach the right side collar.

Rear wheel disassembly

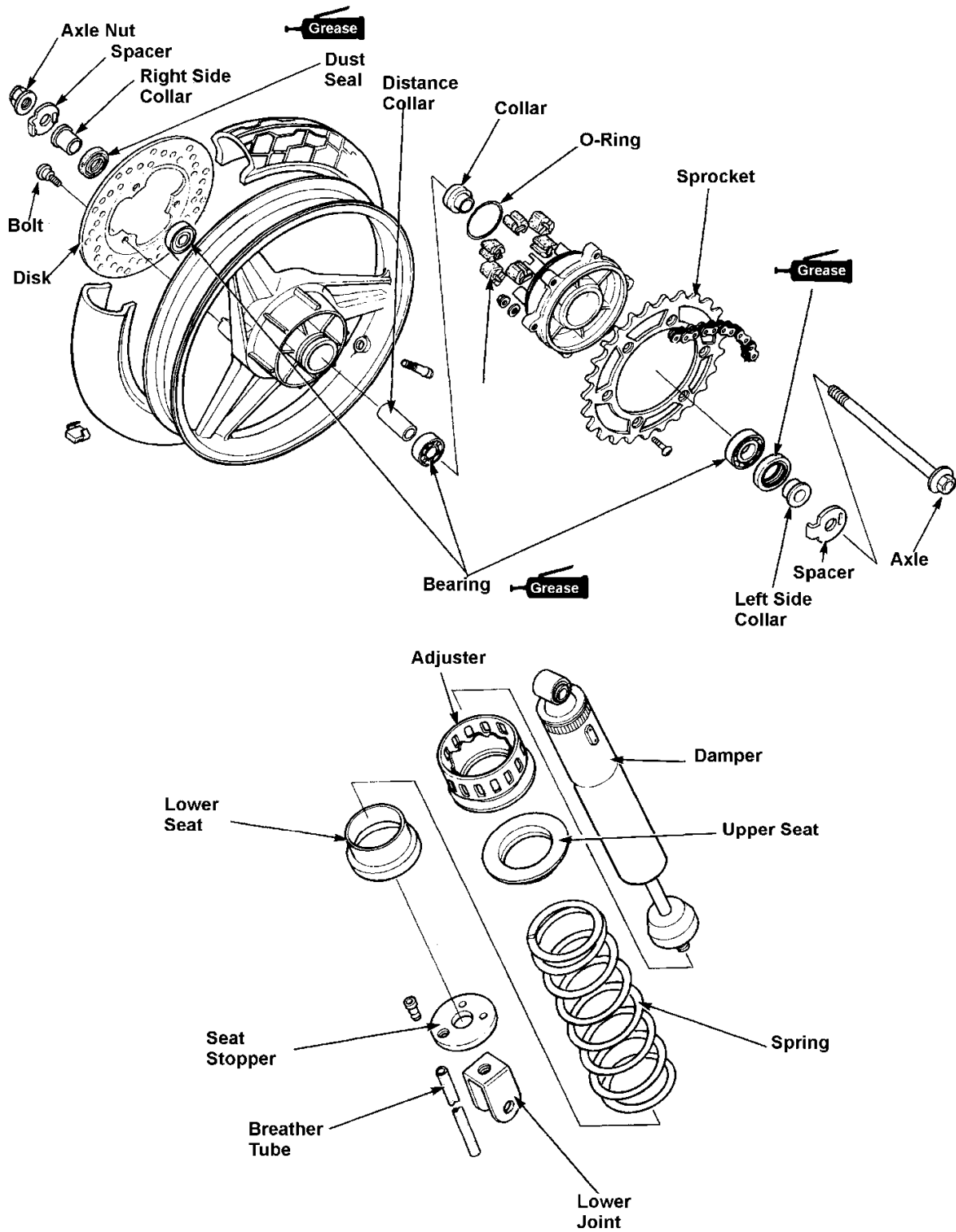

## Suspension linkage

### Detachment

Remove conrod bolts (frame and cushion sides) and remove the cushion conrod.

Remove the rear cushion lower bolt.

Remove the cushion arm – rear fork pivot pinch bolt.

Remove the pivot shaft and detach the cushion arm.

Cushion arm – rear fork pivot bearing replacement

Remove the dust seal.

Remove the needle bearing by using a bearing remover.

#### Exc. tools

Bearing remover (15mm)	07936-KC10000
Remover ASSY	07936-KC10500
Remover shaft	07936-KC10100
Remover head	07936-KC10200
Remover sliding weight	07741-0010201

Fill grease to the needle bearing.

Attach the needle bearing to the cushion arm by using a hydraulic press machine.

#### Common tools

Driver handle A	07749-0010000
Outer driver (24x26mm)	07746-0010700
Pilot (15mm)	07746-0040300

Press the marked surface in

Assemble the cushion arm (14-17).

### Attachment

Attach the cushion arm and a cushion conrod.

Attach the cushion arm – rear fork pivot shaft.

Tighten each bolt with torque specified as follows:

### Torque:

Cushion arm – rear fork pivot pinch bolt	2.0 ~ 3.0kg-m
Rear cushion lower bolt	5.0 ~ 6.0kg-m
Conrod bolt (frame side)	5.0 ~ 6.0kg-m

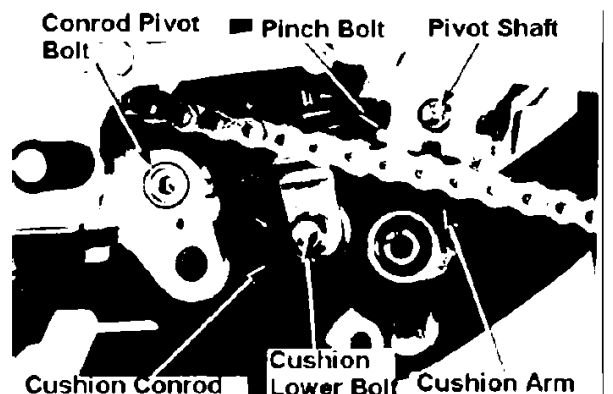
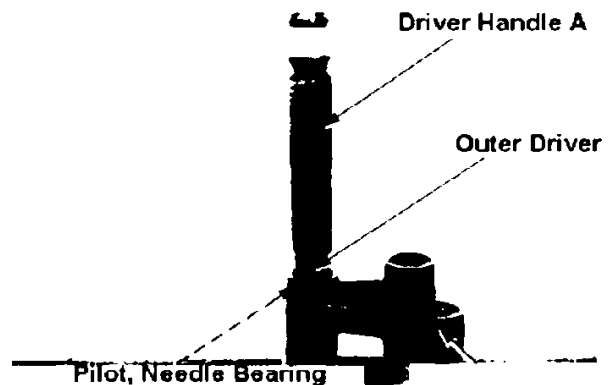
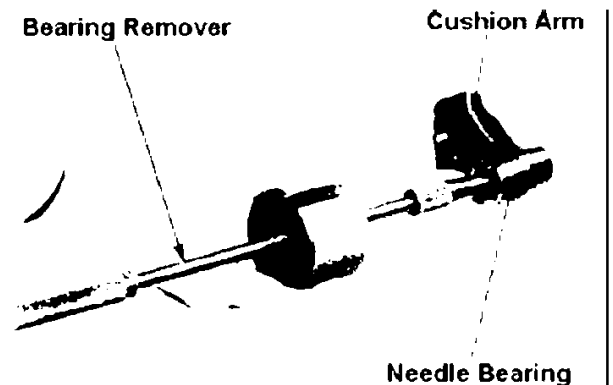
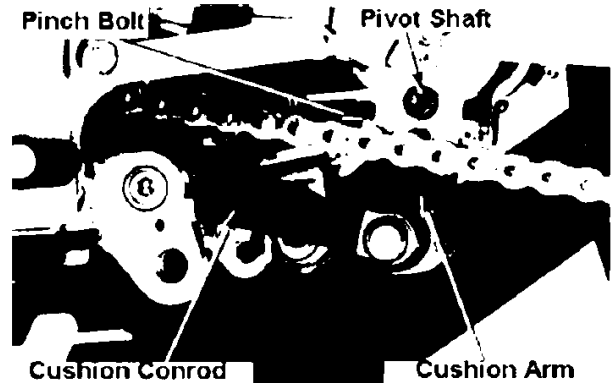

Tighten the conrod bolt (cushion arm side).

**Torque:** 5.0 ~ 6.0kg-m

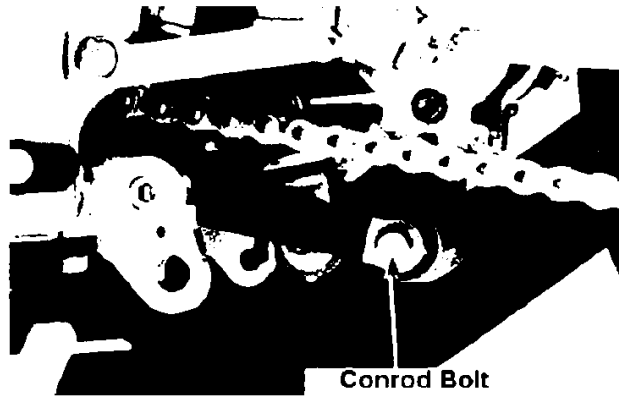

Conrod Bolt

## Rear fork bearing replacement

Detach the rear wheel (21-24)  
Detach the rear fender B (16-2)  
Detach the cushion arm (21-26)  
Remove the rear fork (14-18)  
Remove the right pivot collar and dust seal.



Dust Seal

Pivot Collar

Remove the chain slider.  
Remove the left pivot collar and the dust seal.

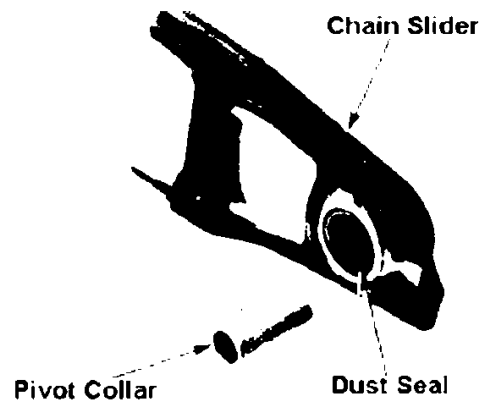

Chain Slider

Pivot Collar

Dust Seal

Remove the circlip.  
By using a bearing remover, remove the right pivot bearing (ball-bearing).

### Exc. tools

Bearing remover (15mm)  
07936-KC10000  
Remover ASSY (15mm)  
07936-KC10500  
Remover shaft (15mm)  
07936-KC10100  
Remover head (15mm)  
07936-KC10200  
Remover sliding weight  
07741-0010201

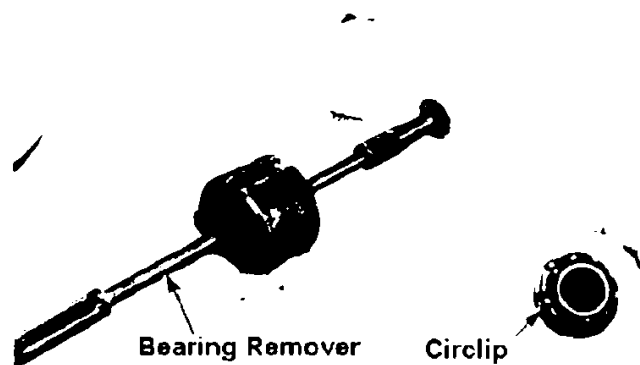

Bearing Remover

Circlip

**21-27**

Remove the distance collar.

Remove the left pivot bearing  
(needle bearing).

Exc. tool

Driver handle 07949-3710001  
Driver attachment (28 x 30mm) 07946-1870100

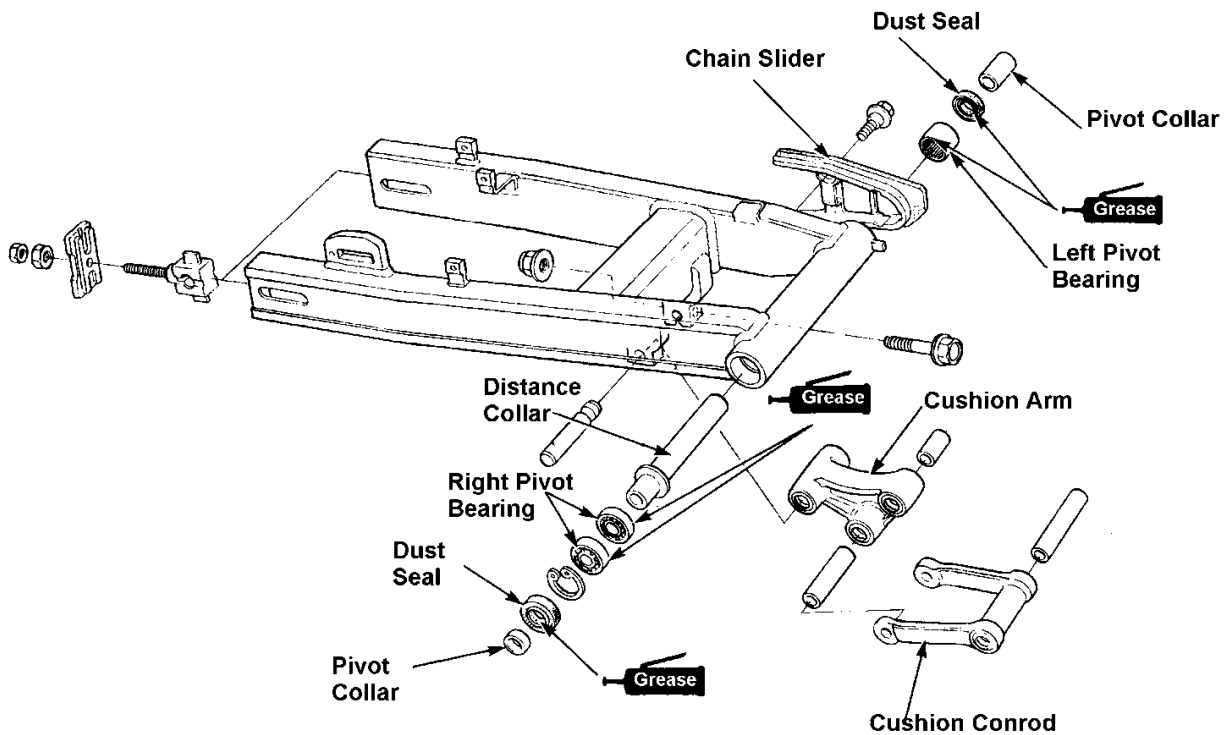
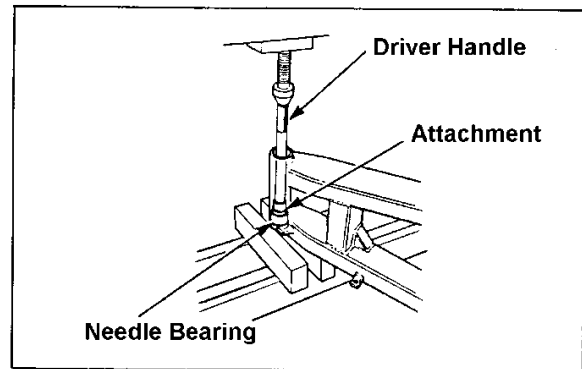
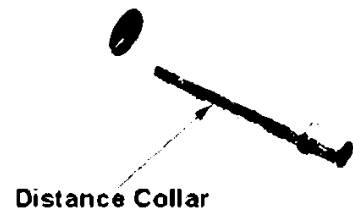

Fill grease to a roller of the needle bearing.

By using hydraulic press machine, insert the left pivot bearing (needle bearing).

Exc. tool

Needle bearing driver attachment  
07HMD-KV30100

Common tool

Driver handle A      07749-0010000

Push the marked surface in.

Install the distance collar.

Fill the bearing with grease.

By using hydraulic press machine, insert the right pivot bearing (ball-bearing).

Common tools

Outer driver (32x35mm)      07746-0010100  
Pilot (15mm)              07746-0040300  
Driver handle A              07749-0010000

Press the marked surface in.

Firmly attach the circlip to the groove.  
Apply grease to the lip of the left pivot dust seal and attach it.  
Attach the left pivot collar.  
Attach the chain slider.

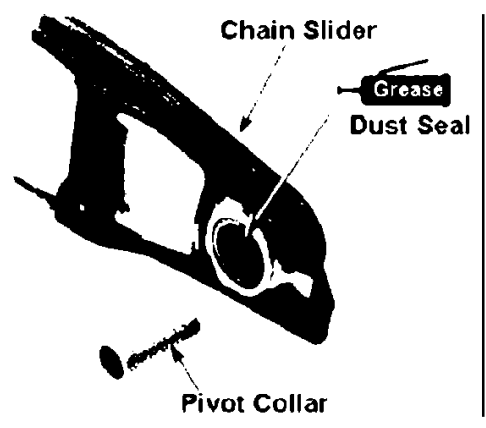
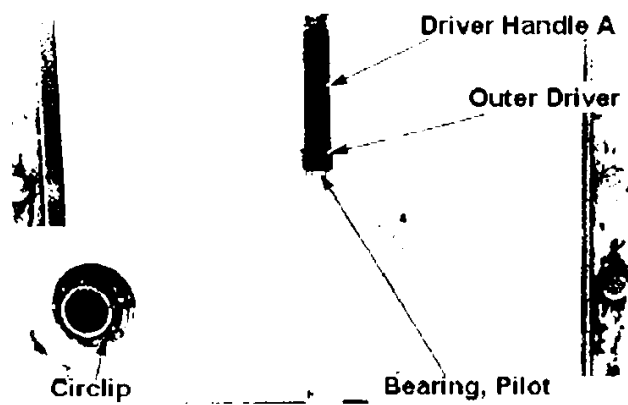
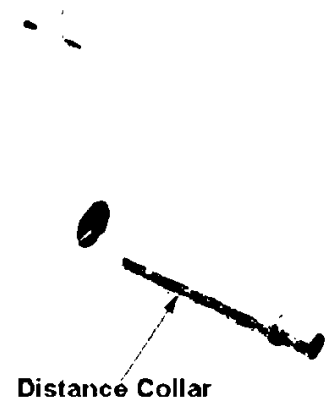
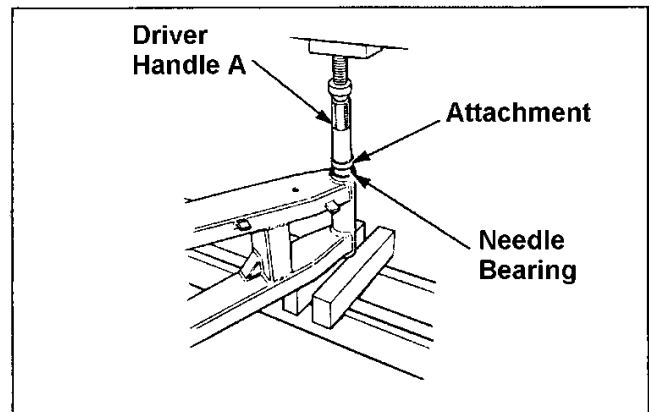

Apply grease to the lip of the right pivot dust seal and attach it.

Attach the right pivot collar.

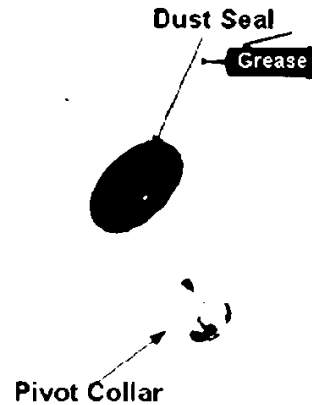

Attach the rear fork (14-22).

Attach the rear fender B (16-2).

Attach the cushion arm (21-27).

Attach the rear caliper to a rear fork by aligning the projection on the caliper with the slit on the fork.

Attach the rear wheel (21-24).

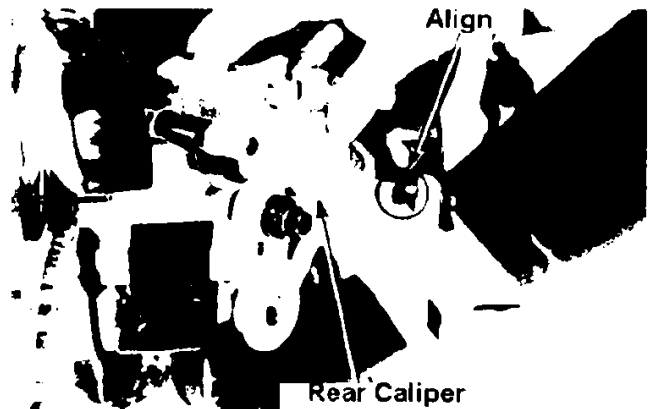



**Brake system (Disk Brake)**

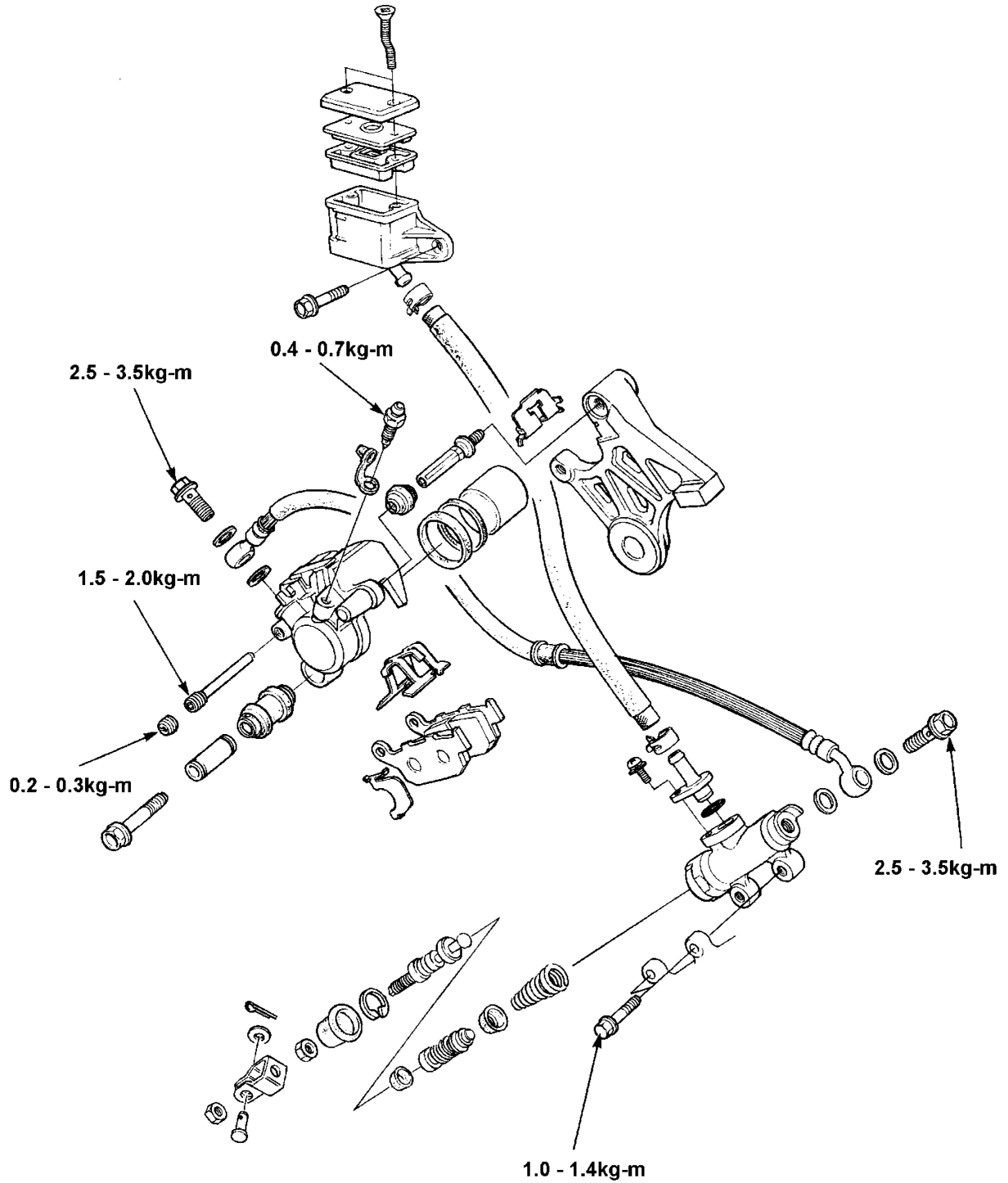

## Service information Standard

Thick lined cells differ from CBR250 four.

Item	Standard	Limitation
Rear brake disk thickness	4.8-5.2	4.0
Rear brake disk deflection	-	0.3
Rear master cylinder inner diameter	12.700-12.743	12.755
Rear master piston outside diameter	12.657-12.684	12.645
Rear caliper cylinder inner diameter	38.180-38.230	38.240
Rear caliper piston outside diameter	38.115-38.148	38.103

## Brake fluid change / air bleeding

Refer to 15-3 for front brake fluid change / air bleeding.

Check the brake fluid level on the rear brake reservoir.

- Brake fluid check and refill should be done by placing the reservoir cap top surface horizontal.
- Keep out of debris and water when refilling the fluid.
- Do not mix different products of brake fluid.
- Keep the painted, plastic and rubber surfaces out of the brake fluid.
- Use DOT 3 or DOT 4 brake fluid.

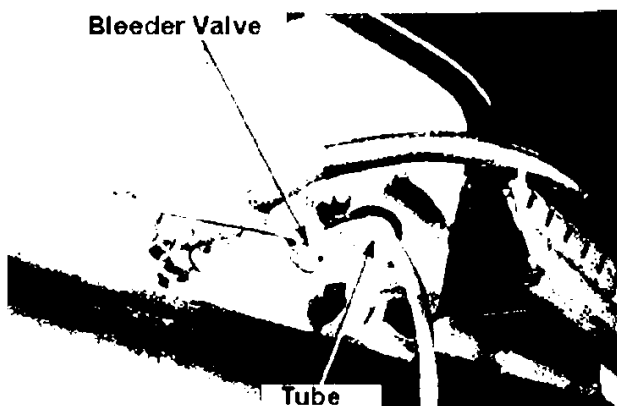
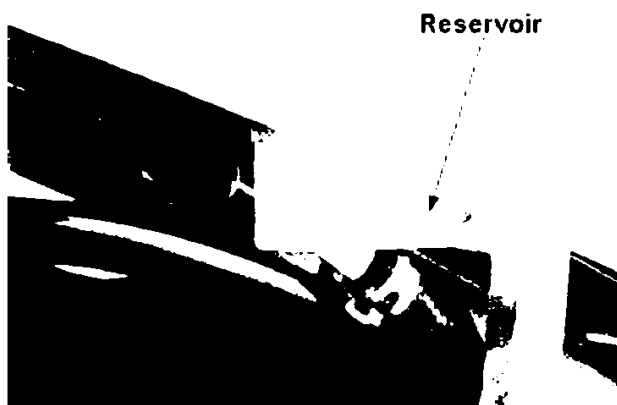

## Brake fluid bleeding

Remove the reservoir cap.

Connect the transparent tube to a bleeder valve.

Loosen the bleeder valve on the caliper and operate the brake pedal.

Repeat this until the brake fluid stops coming out from the bleeder valve.

- Keep brake disk / pads clean to avoid lowering braking performance.
- If they become dirty, replace with new pads and wipe off dirt from the brake disk.

## Air bleeding

- Keep monitoring the brake fluid level. Supply brake fluid if the fluid level comes down to the lower limit and resume work.

Tighten the bleeder valve and refill brake fluid to the upper limit line.

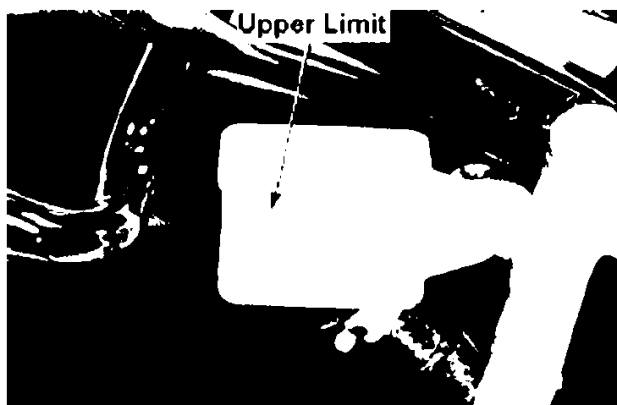

Operate the brake pedal and bleed air. Repeat this until no air comes out to the reservoir (until the brake pedal becomes heavy).

Refill brake fluid to the upper limit line.

Attach the transparent pipe to the bleeder valve on a caliper and place a container.

- 1) Operate the brake pedal several times and loosen the bleeder valve 1/2 rev, while holding the pedal depressed, and then re-tighten.

Do not release the pedal until you re-tightened the bleeder valve.

- 2) Slowly release the brake pedal and leave it for a few seconds in original position.

Repeat 1) and 2) until no air comes out from the bleeder valve.

Refill brake fluid to the upper limit. Tighten the bleeder valve.

**Torque: 0.4 ~ 0.7kg-m**

### Brake pad / disk

### Brake pad change

- Refer to 15-4 and 6 for front brake pad change and brake disk inspection.
- Do not disconnect brake hose

Remove the rear caliper attachment bolt.

Push the caliper piston back to fit new pads.

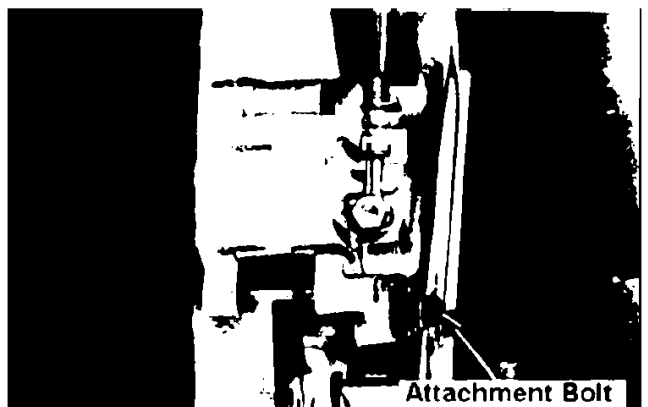
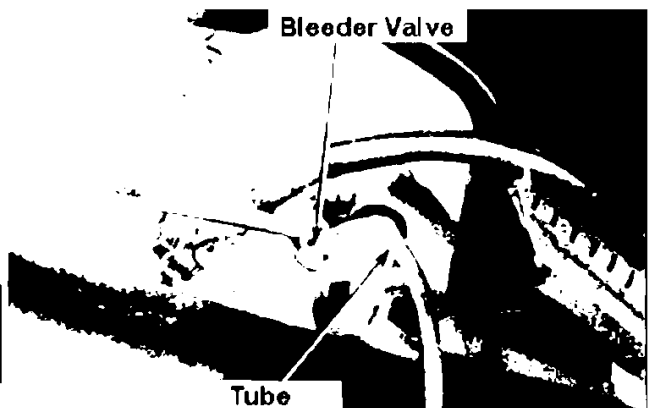
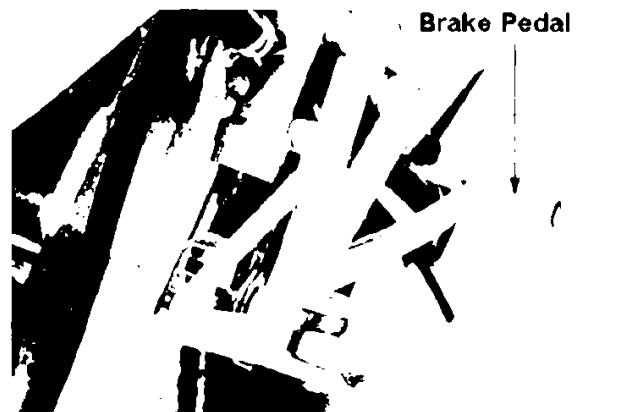

Remove the plug and the hanger pin.

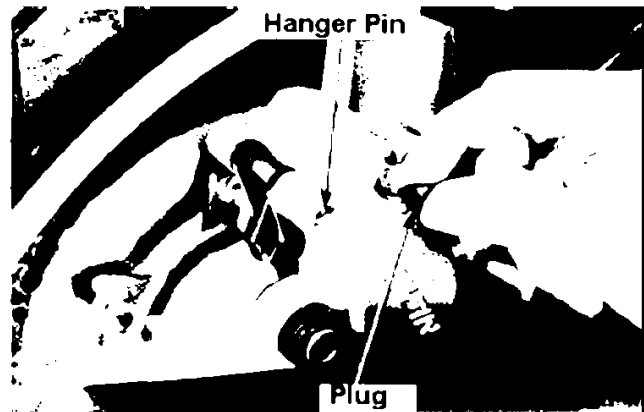

Detach the pads from the caliper.  
 Confirm the pad spring attachment position.  
 Attach new pads to the caliper.

- Replace brake pads in a pair.
- Attach the retainer-fitted pad to the piston side.

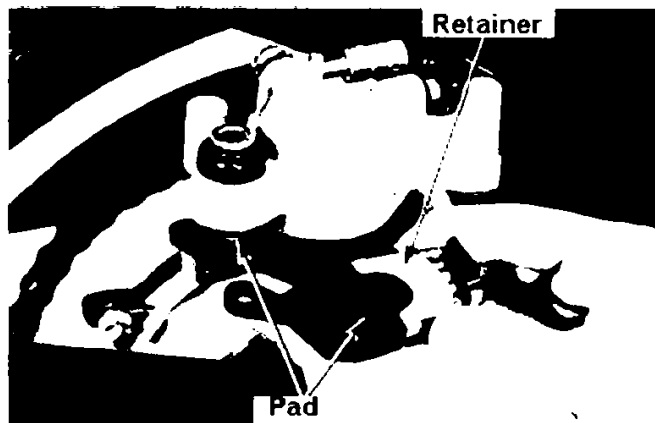

Attach the caliper to the caliper bracket and attach the hanger pin and tighten.  
**Torque: 1.5 ~ 2.0kg-m**

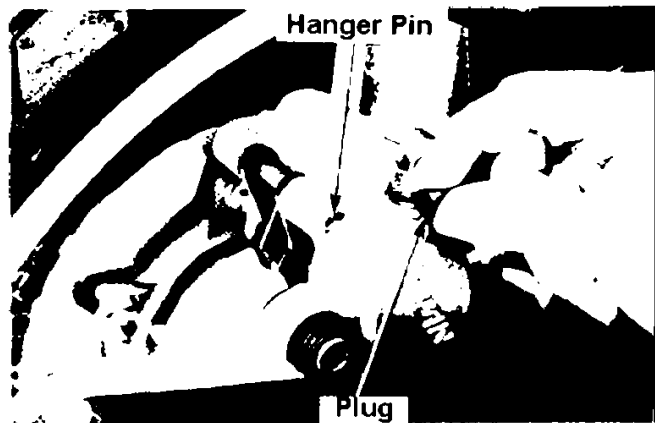

Attach the hanger pin plug.  
**Torque: 0.2 ~ 0.3kg-m**

Apply silicone grease to the rear caliper attachment bolt and tighten it.  
**Torque: 2.0 ~ 2.5kg-m**

Operate the brake pedal after replacing the pads to push the piston



## Brake disk inspection

Measure the brake thickness.  
 $\leq 4.0\text{mm}$  → Replace

Measure the disk deflection.  
 $\geq 0.3\text{mm}$  → Replace

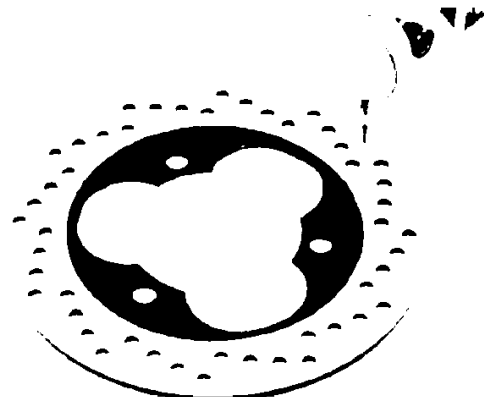

## Master cylinder

Refer to 15-6, -7, -8 for front master cylinder.

## Front brake lever adjuster

Remove the front master cylinder (15-6).  
 Detach the brake lever from the master cylinder and remove screws, adjuster arm, rod, adjuster and the joint pin.  
 Inspect the spring for its tension.  
 Apply small amount of grease on the joint pin hole and attach it to the brake lever.  
 Attach the adjuster and a rod and attach them to the joint pin.  
 Attach the adjuster arm to the brake lever and tighten the screws.

Align the marking on the adjuster with the arrow symbol on the joint pin when attaching.

Attach the brake lever to the master cylinder and attach the front master cylinder (15-8).

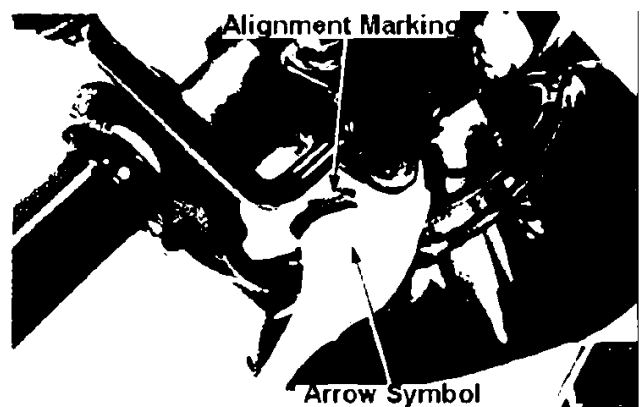
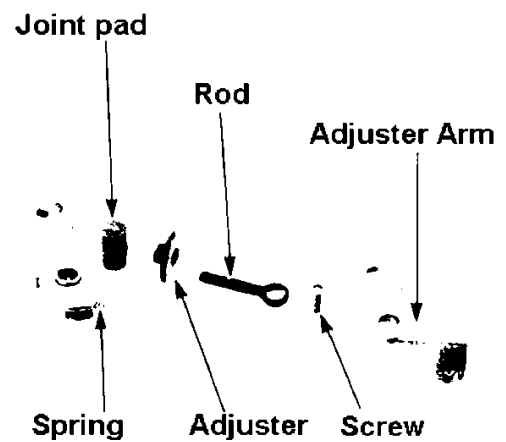

## Rear master cylinder

### Detachment

- Keep the painted, plastic and rubber surface away from brake fluid.
- Apply cover to the hose joint to prevent brake fluid leak.

Bleed brake fluid (21-32).

Remove the brake hose attachment bolt and disconnect the brake hose from the master cylinder.

Remove the lock nut and remove a push rod from a joint.

Remove one attachment screw and disconnect the reservoir hose from the master cylinder.

Remove two master cylinder attachment bolts and detach the master cylinder.

### Disassembly

Remove the dust boot and remove the circlip.

Exc. tool Snap ring pliers  
07914-3230001

Remove the piston, piston cup and spring from the master cylinder and clean the inside of the cylinder with brake fluid.

- Clean the removed parts with brake fluid and check the path of each part with compressed air.
- Sort the parts to keep them away from dust and debris.

### Inspection

Inspect the master pistons contact surface for damage or scratch.

Measure the inner diameter of the master cylinder.

$\geq 12.755\text{mm}$  → Replace

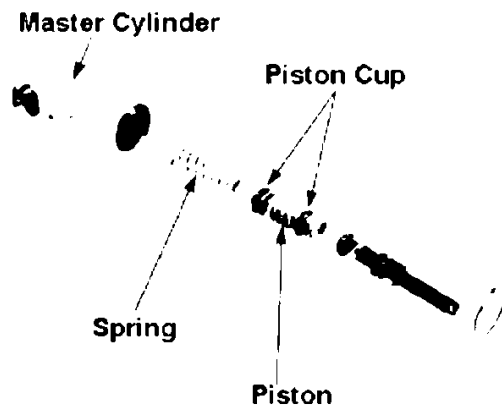
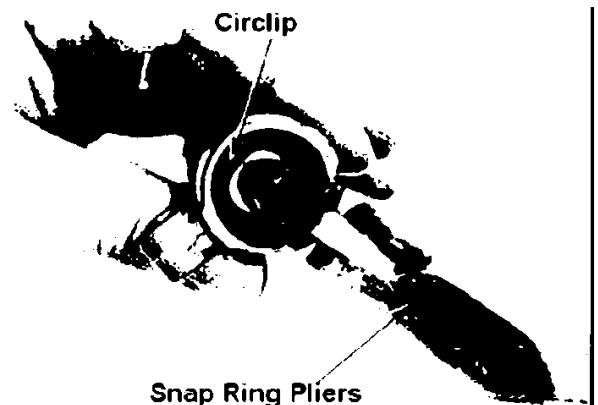
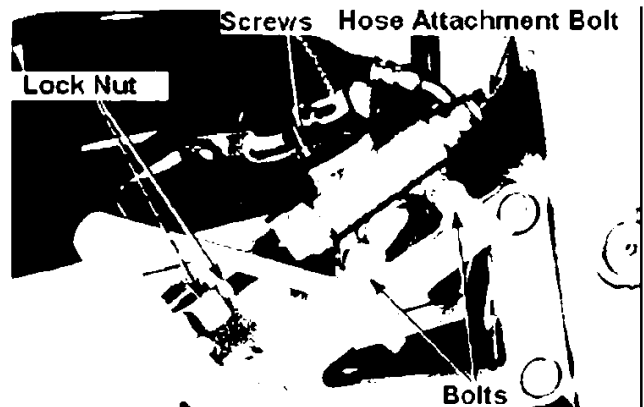

Inspect the surface of the master piston for damage and scratch.

Inspect the piston cup for wear and damage.

Measure the outside diameter of the master piston.

≤ 12.645mm → Replace

### Assembly

- Make sure each part is clean before the assembly.
- Do not re-use old brake fluid.
- Replace the master cylinder piston, spring, cup and the circlip altogether.

Apply brake fluid to the piston cup and attach it to the piston.

Apply brake fluid to the inner surface of the master cylinder.

Install the spring, primary cup and the piston to the master cylinder and hold with the circlip.

- Do not turn the lip over when installing the cup.
- The smaller coil diameter of the spring comes to the piston side.
- Firmly set the circlip into the groove.

Exc. tool

Snap ring pliers      07914-3230001

Attach the dust boot.

Install the push rod and the joint section.  
Attach the master cylinder with two bolts.

**Torque: 1.0 ~ 1.4kg-m**

Attach the brake hose by using new sealing washers (two) and the brake hose attachment bolt.

**Torque: 2.5 ~ 3.5kg-m**

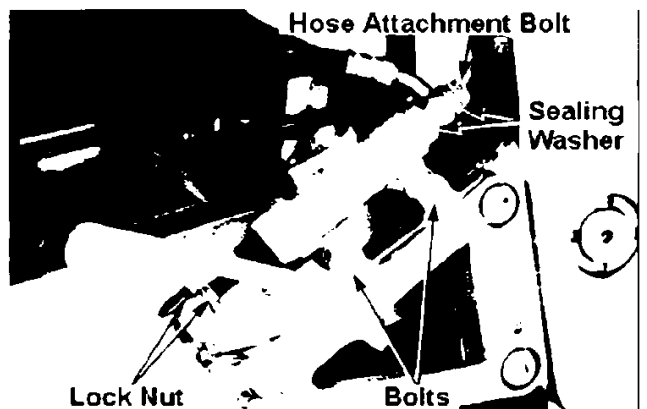
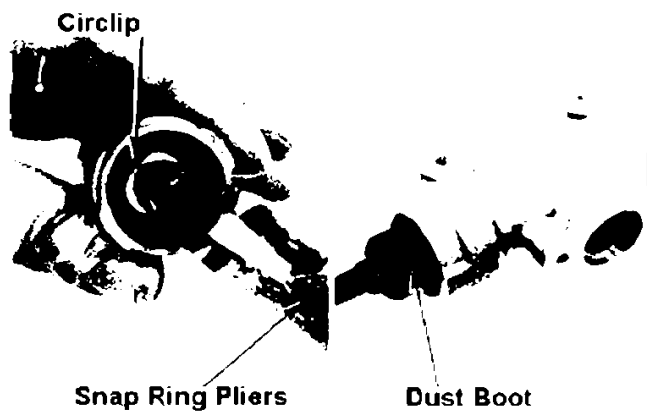
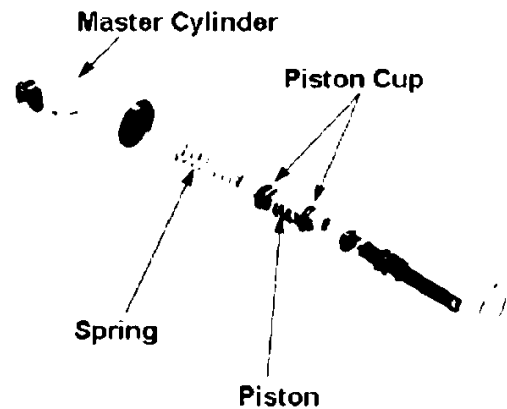

Attach an O-Ring to the reservoir hose and connect the hose to a master cylinder with attachment bolt.

Refill brake fluid and bleed air (21-32).

### Brake caliper

Refer to 15-9, -10, -11 for front brake caliper.

### Caliper detachment / disassembly

Keep all parts away from brake fluid.

Bleed brake fluid (21-32).

Remove the brake hose attachment bolt and detach the brake hose from the master cylinder.

Remove the rear caliper attachment bolt and detach the rear caliper.

Remove the pad, pad spring, boot and the pivot collar from the caliper.

Wrap with the cloth to prevent piston and brake fluid coming out, and turn the piston downwards.

Gradually apply low pressure air from the brake hose attachment and remove the piston from the caliper.

- Do not use high pressure air or bring the air gun too close.
- Do not insert your hand inside the caliper.

Remove the piston seal and adjust seal by pushing them into the piston.

Exercise caution not to damage the inner surface of the caliper cylinder.

Clean the inner surface of the caliper with brake fluid and remove dirt from creeks.

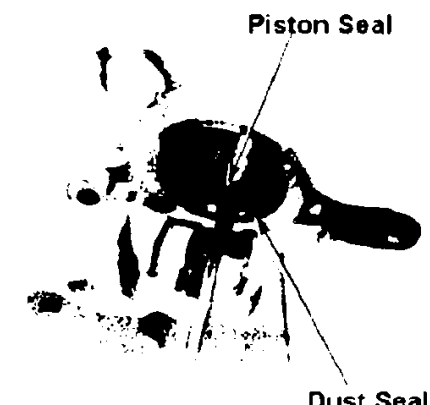
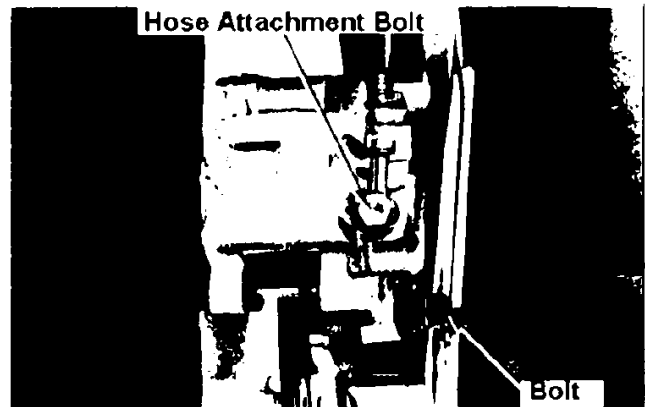
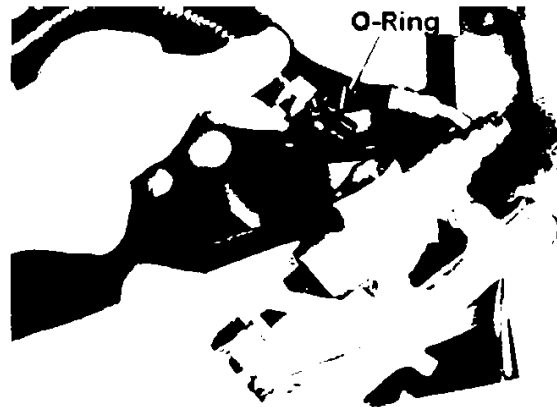



## Inspection

Inspect the exterior surface of the caliper piston for damage and scratch.  
Measure the outside diameter of the piston  
 $\leq 38.105\text{mm}$  → Replace  
Inspect the inner surface of the cylinder for damage scratches.  
Measure the inner diameter of the caliper cylinder.  
 $\geq 38.240\text{mm}$  → Replace  
Caliper assembly / attachment

- Check all parts are clean before the assembly.
- Do not re-use old brake fluid.
- Replace the piston seal and the dust seal whenever the caliper is reassembled.

Apply brake fluid to new piston seal and dust seal and set them to the grooves on the caliper cylinder.  
Install the piston to the caliper.  
Attach the boot, collar and the pad spring.

- Apply silicone grease to the boot.
- Firmly set the boot to the groove on the caliper.

Attach brake pads to the caliper and attach the caliper to the bracket.  
Set the rear caliper by tightening the attachment bolt.  
**Torque: 2.0 ~ 2.5kg-m**

Attach the hanger pin to the caliper.  
**Torque: 1.5 ~ 2.0kg-m**

Attach the hanger pin plug.  
**Torque: 0.2 ~ 0.3kg-m**  
Attach the brake hose with two new sealing washers and the brake hose attachment bolt.

Set the hose to groove on a caliper.

**Torque: 2.5 ~ 3.5kg-m**  
Fill brake fluid and bleed air (21-32).

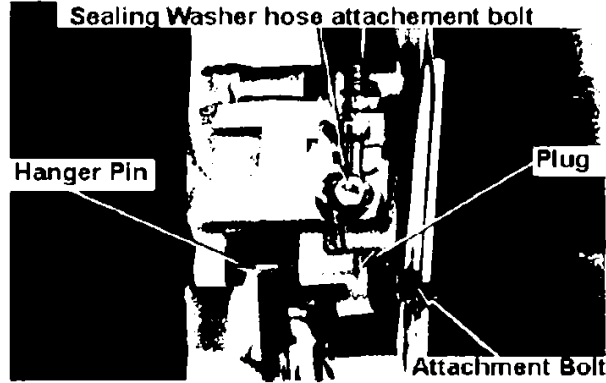
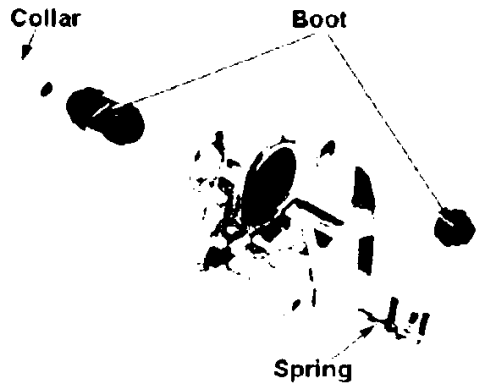
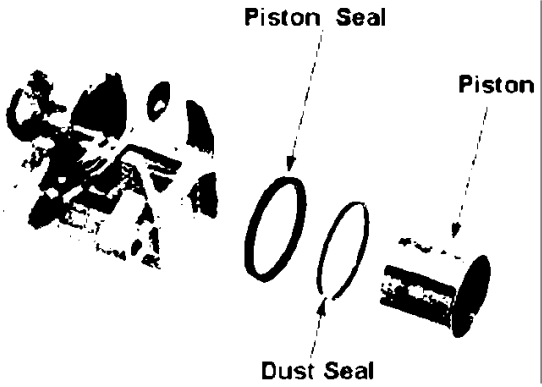
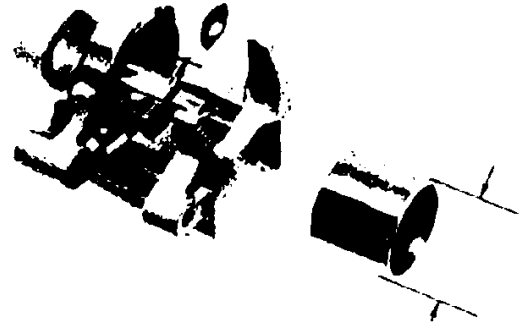

## Brake Pedal Detachment

Remove right step attachment bolts.  
Remove the push rod joint from the brake pedal.  
Remove the circlip and detach the pedal.  
Remove the spring from the pedal.

## Attachment

Apply grease to the pivot and attach the brake pedal to the right step pivot.

Install the spring to the brake pedal.

Install the circlip to the groove on the brake pedal pivot.

Connect the pedal and the push rod with the joint pin and attach the washer and the new cotter pin with the joint pin.

Attach the right step with two bolts.

Torque: 2.5 ~ 3.0kg-m

Adjust the height of the brake pedal (21-9).

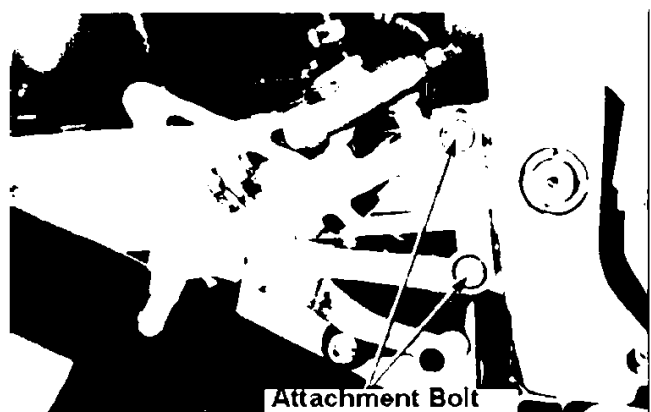
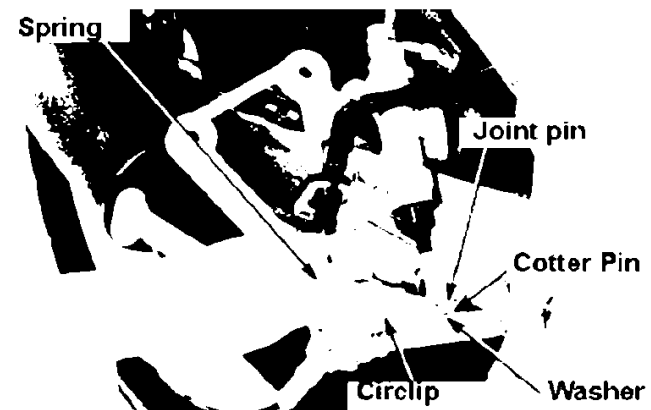
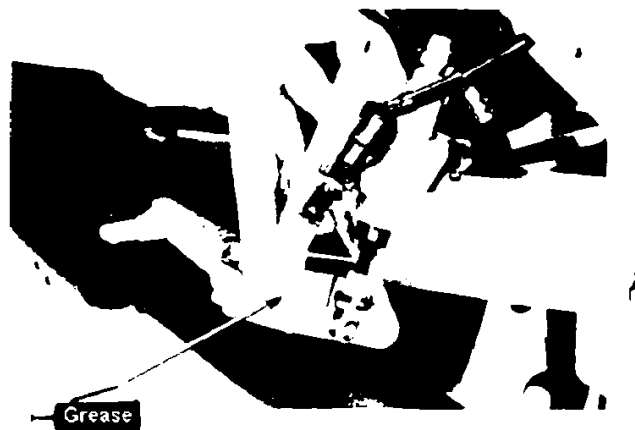
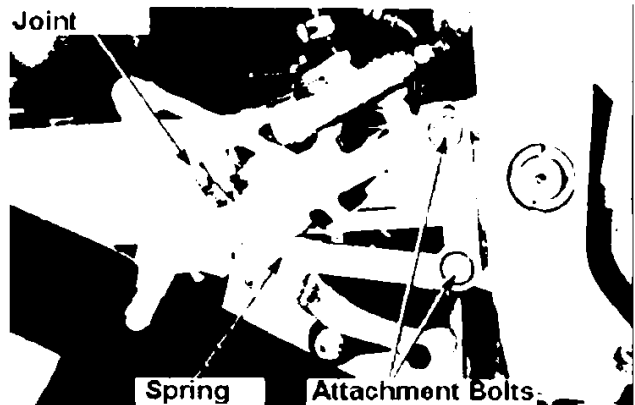

## Seat Cowl

### Detachment

It is not necessary to detach side covers and the front seat in order to detach only the seat cowl.

Remove side cover attachment screws.  
Release four catches on the side cover and detach the side cover.

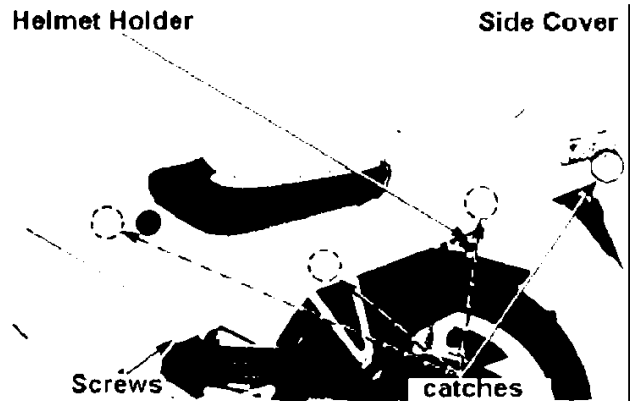

Remove two bolts and detach the front seat.  
Release the lock of the helmet holder.  
Lift and slide the tandem seat back.

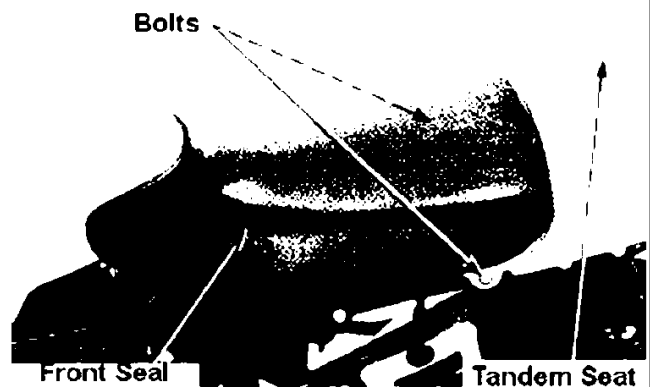

Remove two rear cowl attachment bolts and detach the rear cowl from the rear catch.

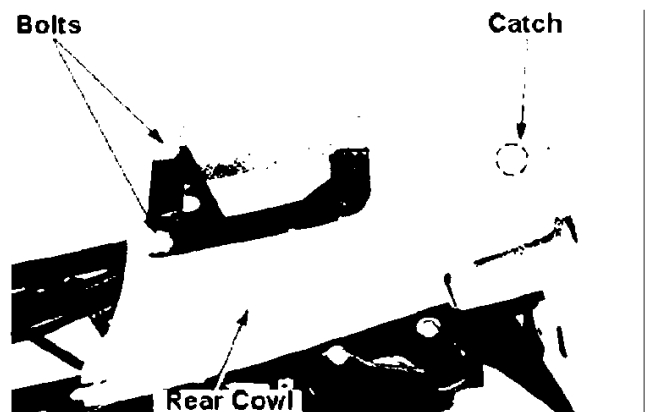

**Attachment**

Reverse the detachment procedure.

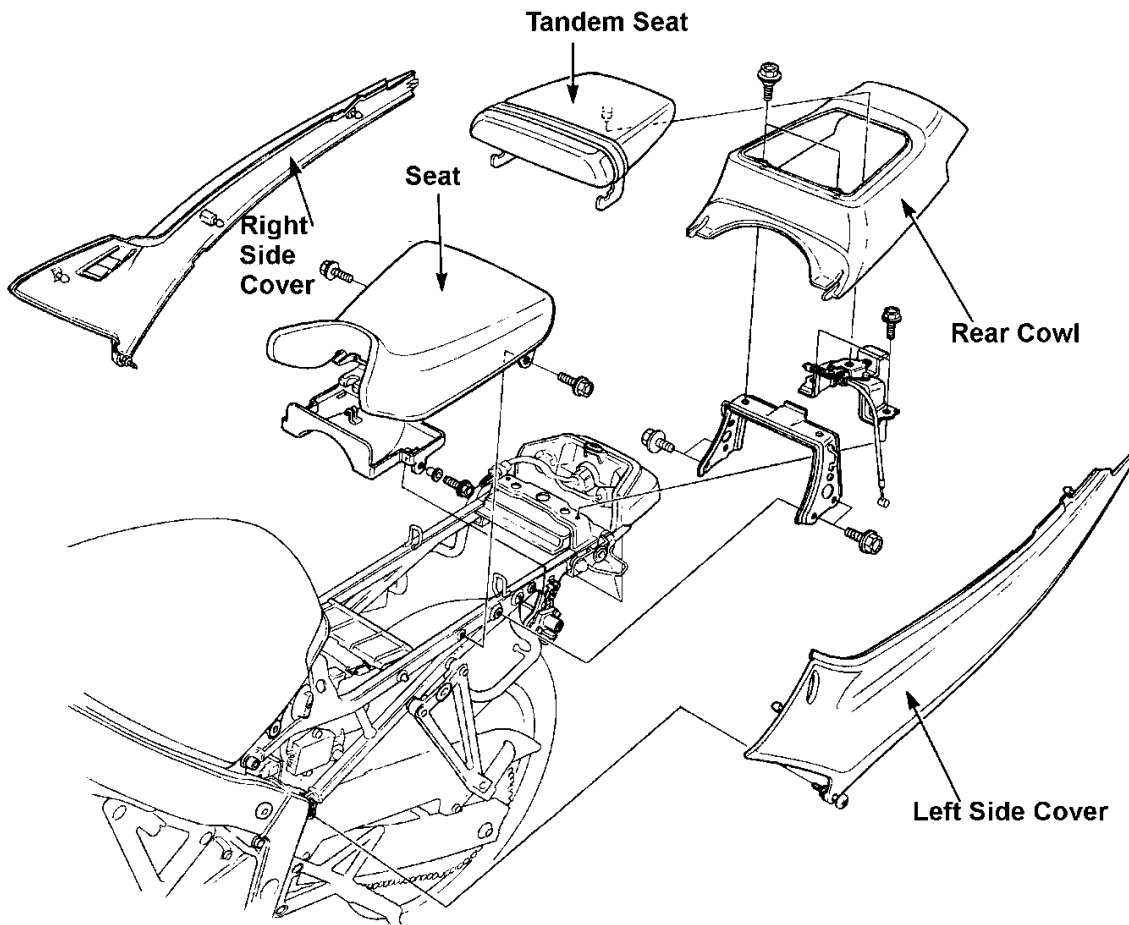

## Sub Frame

Plastic clips detachment / attachment

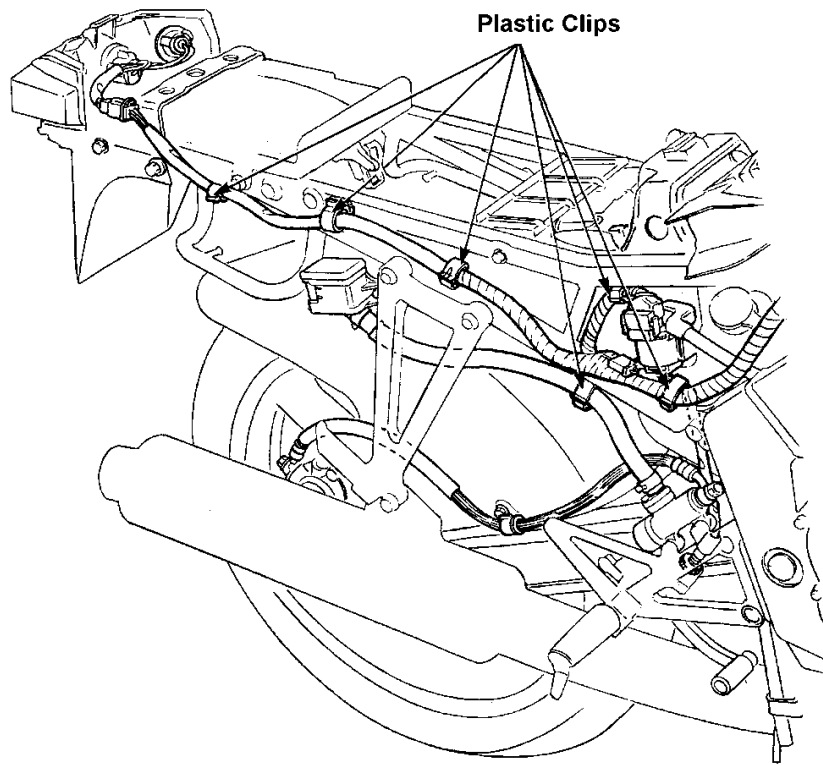

When detaching wire harness and hose, release the lock by opening the catch with a screwdriver.

Detach the harness and hose from the clip. When attaching them to the clip, set them to the clip and push in until the catch is locked ("click" sound).

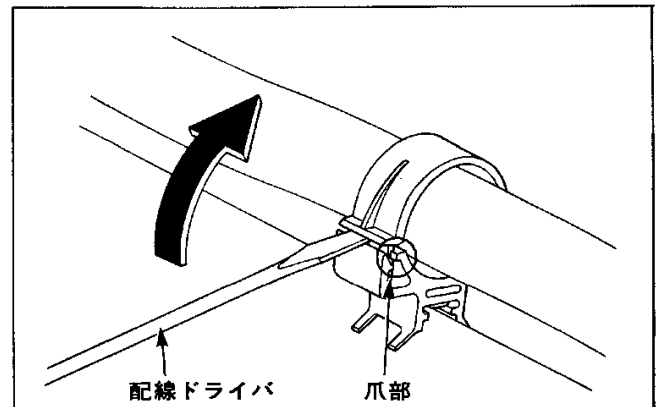

Replace with new clips whenever dismantled from the frame.

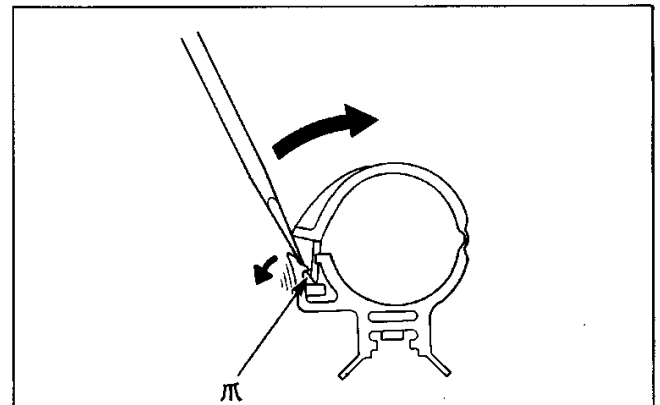

## Table of Contents

Specifications.....	22-2
Torque Settings.....	22-3
Exclusive / Common Tools.....	22-3
Wiring.....	22-4
Circuits.....	22-8
Service Data.....	22-9
Inspection / Adjustment.....	22-15
Fuel System.....	22-19
Engine mounting / dismounting.....	22-22
Cylinder Head, valve.....	22-23
Front wheel attachment / detachment.....	22-24
Rear wheel, Suspension.....	22-25
Brake system (Disc brake) .....	22-29
Fairing.....	22-30
Lights, Instructions and Switches.....	22-32

# CBR250R (J)

## Specifications

Thick lined cells are different from  
CBR250FOUR / CBR250R

Type	Honda MC19			
Length	2.020m			
Width	0.685m			
Height	1.075m			
Wheelbase	1.365m			
Type of powerplant	MC14E			
Total displacement	0.249l			
Type of fuel	Petrol			
Vehicle weight	Front	77kg		
	Rear	77kg		
	Total	154kg		
Maximum capacity	2			
Gross weight	Front	94kg		
	Rear	170kg		
	Total	264kg		
Tyres	Front	100/80 – 17 52H		
	Rear	140/70 – 17 66H		
Minimum clearance	0.135m			
performance	Brake stop Distance (initial km/h)	14.0m (50km/h)		
	Minimum Turning radius	2.9m		
Powerplant:	Engine start	Self start		
	Type of engine	Petrol, 4 – cycle		
	Cylinders	4 in-line sideways		
	Combustion chamber	Pent roof type		
	Valve system	DOHC gear driven Inlet 2, exhaust 2		
	Bore x stroke	48.5 x 33.8mm		
	Compression ratio	11.0		
	Compression	13.0kg/cm <sup>2</sup> - 400rpm		
	Max output	45PS / 15,000rpm		
	Max torque	2.6kg-m / 10,500rpm		
	Valve ops timing	I	Open	19° BTDC (1mm lifted)
			Close	33° ABDC (1mm lifted)
		E	Open	36° BBDC (1mm lifted)
			close	11° ATDC (1mm lifted)
	Valve clearance	IN	0.16mm (cooled)	
		EX	0.23mm (cooled)	
	Idle rpm	1,500rpm		
	Lubrication	Type	Compress/splash	
		Oil pump	Tocoloid	
		Oil filter	Total flow filter. Net / paper filter	
		Oil capacity	2.7l	
	Cooling	Water - cooled		
	Fuel system	Carburetor	Air cleaner	
Fuel capacity			13 l	
Type			VG05	
Gas valve diameter			32mm	
Electrical system	Ignition	Type	Full transistor Battery ignition	
		Timing	23° BTDC / 1500 rpm	
		Spark plug	NGK	CR9EH-9, CR10EH-9
			ND	U27FER9, U31FER9
		Plug gap	0.8-0.9mm	
Clutch	Battery capacity		12V6AH	
	Type	Multiple wet plate coil spring		
	Operation	Mechanical		
Transmission	Engine transmission reduction		2.966	
	Gear ratio	Type	Constant Mesh	
		Gear ratio	First	2.733
			Second	2.000
			Third	1.590
			Fourth	1.333
			Fifth	1.153
			Sixth	1.035
	Reduction gear	First	Gear type	
			Reduction ratio	3.176
Wheels	Front	Caster		
		25°00'		
	Tyre air pressure	Trail		
		89mm		
Steering angle	Front	2.25kg/cm <sup>2</sup>		
	Rear	2.50kg/cm <sup>2</sup>		
Braking system	Left	31°		
	Right	31°		
Suspension System	Front	Hydraulic disk		
	Rear	Hydraulic disk		
Frame type	Front	Telescopic		
	Rear	Swing arm		
Frame No.	Backbone			
Engine No.	MC19 – 1000001 ~			
	MC14E – 1000001 ~			

# CBR250R (J)

Torque setting (only for amended parts)

## Engine

Part	No.	Screw dia (mm)	Torque (kg-m)	Notes
Cylinder head (flange bolt)	12	7	2.7-3.0	
Spark plug	4	10	1.0-1.4	
Right crankcase cover cap bolt	1	14	0.8-1.2	

## Frame

Part	No.	Screw dia (mm)	Torque (kg-m)	Notes
Side stand bracket	2	10	4.5-5.5	
Radiator reserve tank attachment bolt	2	6	1.0-1.4	
Fuel tank attachment bolt (front Rear)	2 1	6 8	1.0-1.4 2.4-3.0	
Air cleaner case attachment screw	6	5	0.35-0.5	
Air cleaner case attachment bolt	1	6	1.0-1.4	
Top bridge split bolt	2	8	2.0-2.5	
Front axle nut	1	14	5.5-6.5	
Front axle pinch bolt	4	8	1.8-2.5	
Front master cylinder holder bolt	2	6	1.0-1.4	
Rear cushion upper bolt	1	10	4.5-5.5	
Cushion conrod (frame side)	1	10	4.5-5.5	
Cushion arm side	1	10	4.5-5.5	
Cushion arm (rear cushion side)	1	10	4.5-5.5	
Lower cowl stay (top, R side)	1	6	0.7-1.1	
(top, L side)	1	6	1.0-1.4	
(Bottom)	4	6	0.7-1.1	
Change pedal attachment bolt	1	8	2.4-3.0	
Change arm	1	6	1.4-1.8	
Exhaust pipe joint nut	8	6	1.0-1.4	
Side cover attachment bolt	2	6	0.7-1.1	
Hook bolt	2	6	1.0-1.4	

## Exclusive / common tools (amended part only)

### Existing exclusive tools

Tools	Tool no.	Part (Application)
Bush driver Assy	07GMD-KT80100	Rear cushion, cushion linkage swing arm
Ball lace remover set Disassembly tool	07946-KM90001 07964-MB00200	Ball lace detach/attachment Swing arm bearing detach/attachment

### Common tools

Tools	Tool no.	Part (Application)
Driver outer 42 x 47mm Remover head (20mm) Fork seal driver attachment	07746-0010300 07746-0050600 07747-0010600	Front wheel R.L. bearing installation Front wheel R.L bearing removal Front fork assembly



# CBR250R (J)

- Wirings

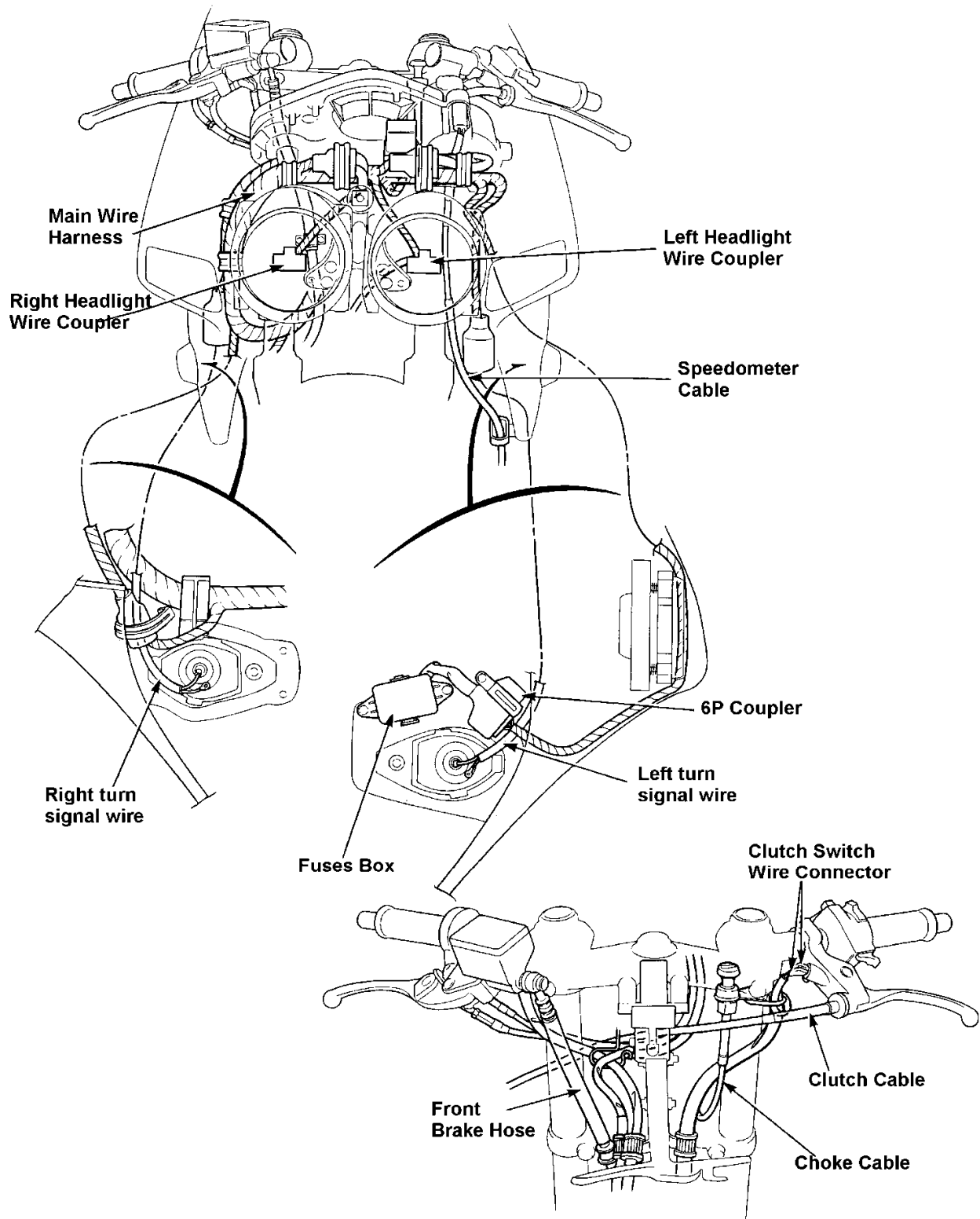

# CBR250R (J)

- Wirings / Cables

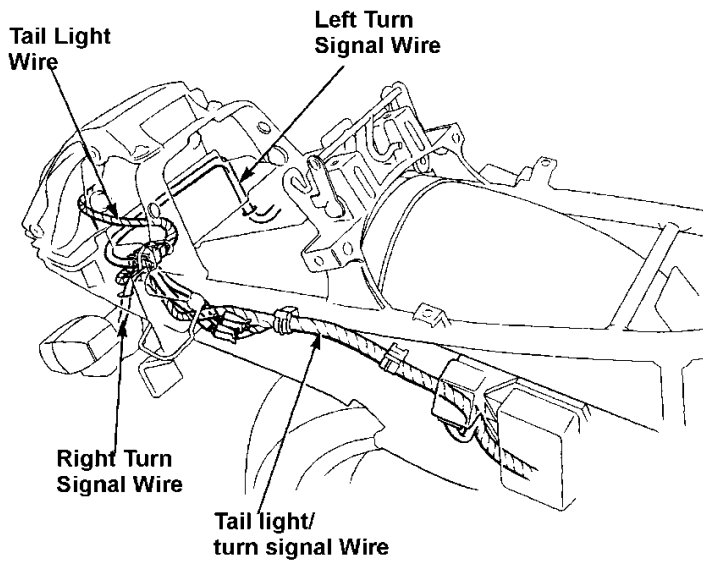
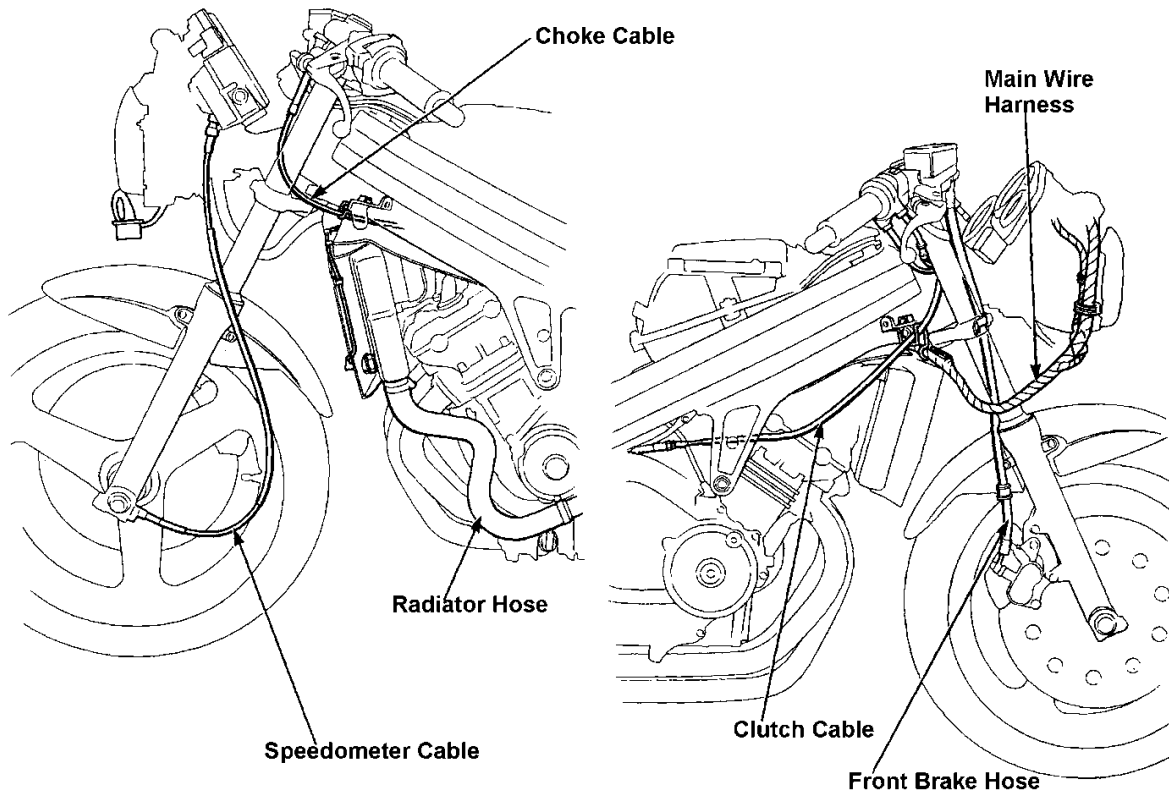

# CBR250R (J)

- Wirings

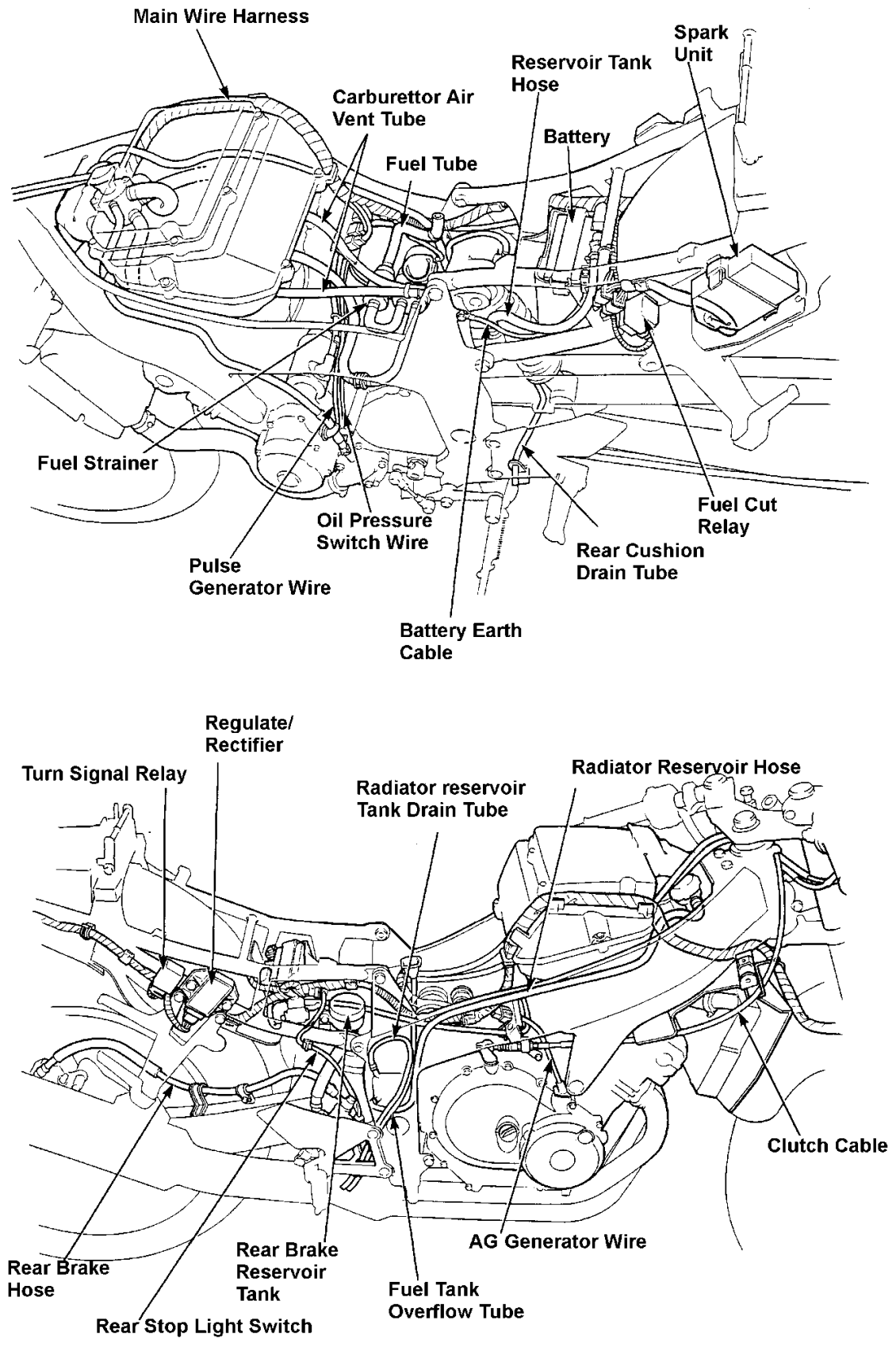

# CBR250R (J)

## • Wirings

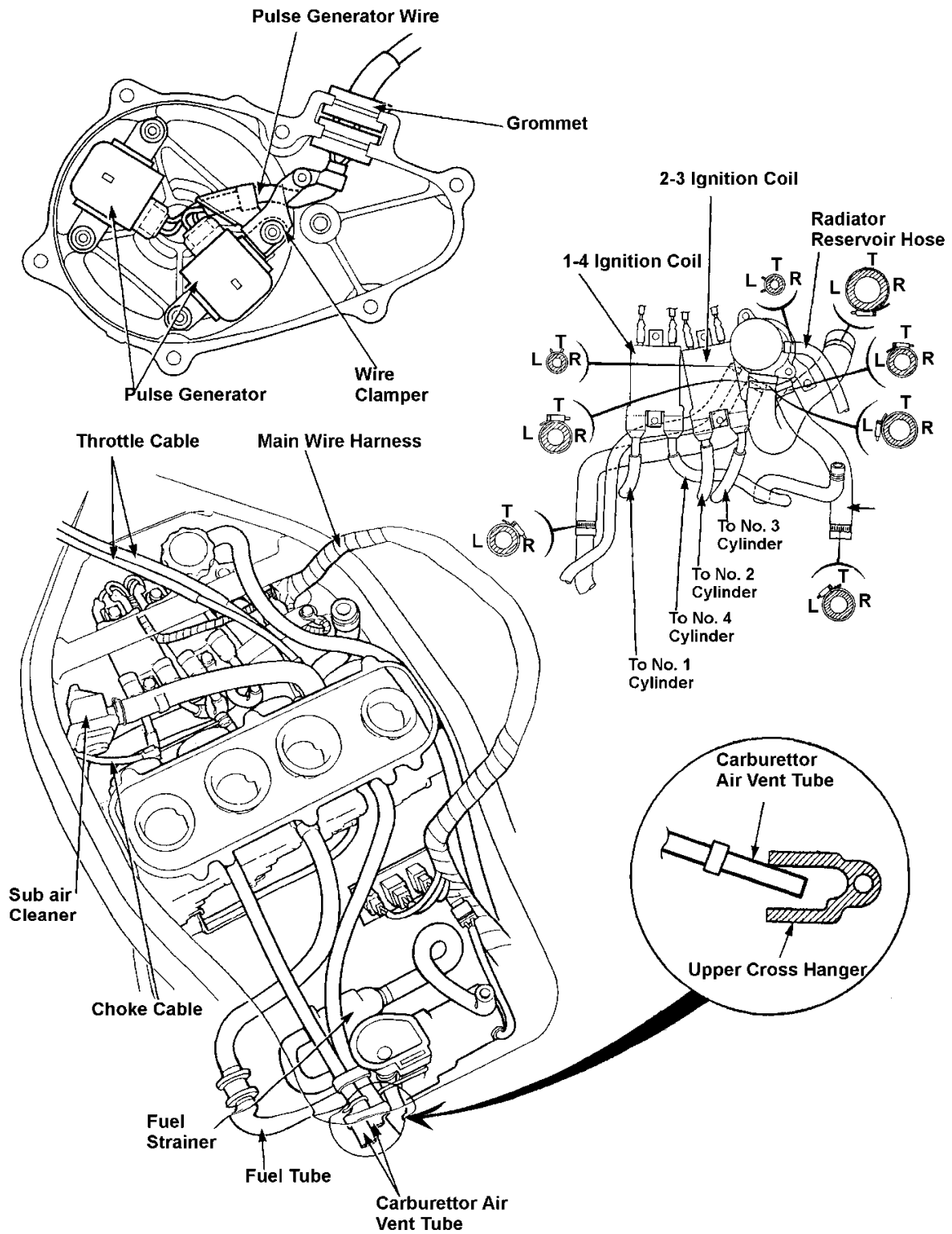

# CBR250R (J)

## Wiring

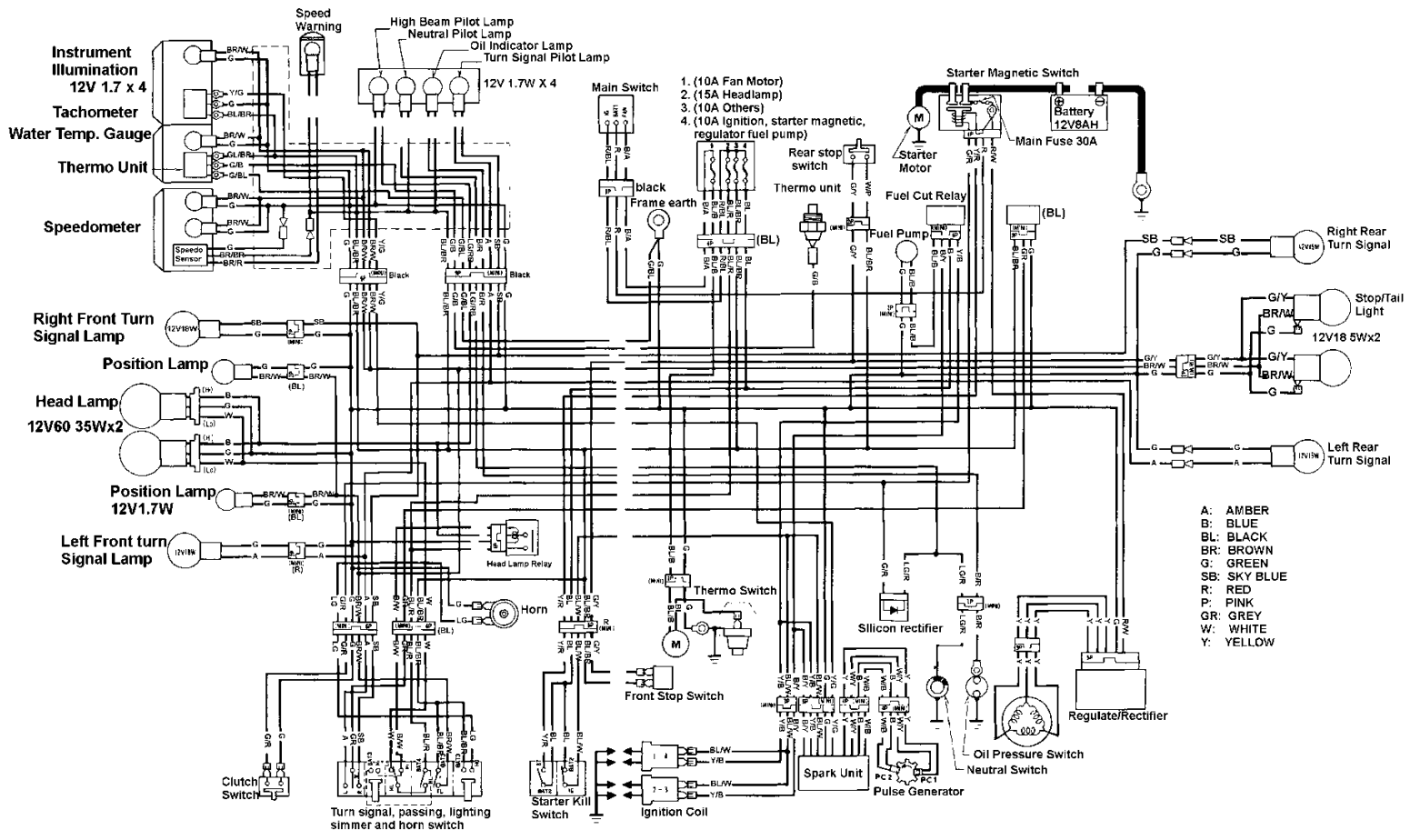

22-8

### SWITCH CONNECTION

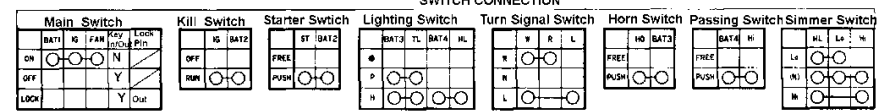

0030Z-KY1-0000

# CBR250R (J)

## Service Data

### Lubrication system

Item	Standard	Standard	Limitation
Oil pump	Rotor tip clearance	0.15	0.20
	Pump body-outer rotor clearance	0.15-0.22	0.35
	Rotor-body clearance	0.02-0.07	0.10
	Pump out pressure	4.0-5.0kg/cm <sup>2</sup> (6.000rpm oil temp 60°C)	

Engine oil capacity	2.2l (oil changed). 2.4l (filter and oil changed). 2.7l (Total)
Designated engine oil	<ul style="list-style-type: none"> <li>Genuine Honda Ultra GP (4cycle motorcycle ASE10W-40 or SAE20W-50)</li> </ul> <div style="border: 1px solid black; padding: 5px; margin-top: 10px;">                     Use the figure to find out the adequate oil viscosity level for your environment.                 </div>

### Fuel system

Item	Standard	
Venturi diameter	Primary bore 9.1mm equivalent, Secondary bore 28.5mm	
Setting mark	VG05A	
Float level	8mm	
Main jet	# 85	
Slow jet	#35	
Idling rpm	1.500 ± 100rpm	
Throttle grip free play	2 – 6mm	
Pilot screw re-winding	1 – 5/8 revs back	
Fuel tank capacity	Total	13l
	Reserve	2l

### Cooling system

Item	Standard	Limitation
Radiator cap valve opening pressure	0.95-1.25kg/cm <sup>2</sup>	0.95kg/cm <sup>2</sup> or less or 1.25kg/cm <sup>2</sup> or above →replace
Thermostat valve Opening temperature	Initial	80 - 84°C
	Full open	95°C
	Full open lift	8mm or more
Coolant capacity	Total 1.500cc	Radiator side 1.300cc Reservoir side 200cc

# CBR250R (J)

## Engine Mount / Dismount

Engine weight (service)		Approx 49kg
Recommended Engine oil		Genuine Honda Ultra GP (4 cycle motor cycle SAE10W-40 or SAE20W-50 APC class SE or SF engine oil → See 3-2 for viscosity
Engine oil capacity	Total capacity	2.7l
	Oil changed	2.2l
	Oil / filter changed	2.4l

## Cylinder Head, Valve

Item	Standard	Standard	Service Limit	
Compression		13.0kg/cm <sup>2</sup>	-	
Camshaft	Cam lift	IN	29.44-29.68	29.41
		EX	28.96-29.20	28.85
	Oil clearance	1	0.015-0.057	0.06
		2	0.015-0.057	0.06
		3	0.025-0.067	0.07
		4	0.015-0.057	0.06
Deflection		-	0.05	
Valve spring		37.3	36.3	
Valve, Valve guide	Valve stem Outside diameter	IN	3.481-3.495	3.47
		EX	3.460-3.475	3.44
	Valve guide bore	IN	3.500-3.512	3.57
		EX	0.005-0.042	3.57
	Stem – guide clearance	IN	0.005-0.042	0.10
		EX	0.005-0.050	0.13
	Valve seat contact Length (span)	IN	0.8	1.3
		EX	1.0	1.5
Valve lifter	Diameter	20.010-20.026	20.035	
Cylinder head	Deflection	-	0.05	
	Valve lifter contact part diameter	19.978-19.993	19.970	

# CBR250R (J)

## Cylinder, Piston, Crankshaft

Item		Standard	Service Limit	
Crankshaft, conrod	Conrod bigger end side clearance	0.05-.02	0.30	
	Crankshaft deflection	-	0.05	
	Crank pin oil clearance	0.028-0.046	0.05	
	Main journal oil clearance	0.030-0.048	0.06	
	Bore	48.500-48.510	48.60	
Cylinder	Top surface distortion	-	0.05	
	Round dimension (distortion from true circle)	-	0.005	
	Cylinder distortion	-	0.005	
	Ring slit – ring clearance	Top Second	0.015-0.050 0.015-0.050	0.10 0.10
Piston ring	Ring gap	Top	0.1-0.25	0.45
		Second	0.15-0.30	0.45
		Oil (side rail)	0.2-0.8	1.00
Piston	Piston diameter	48.47-48.49	48.35	
	Piston – cylinder clearance	0.01-0.04	0.10	
	Piston pin hole diameter	13.002-13.008	13.02	
	Piston pin diameter	12.994-13.000	12.98	
	Piston – piston pin clearance	0.002-0.014	0.04	
	Conrod smaller edge bore	13.016-13.034	13.05	
	Piston pin – conrod clearance	0.016-0.040	0.06	

B = Blue  
BR=Brown  
BL=Black  
Y=Yellow  
G=Green

		Conrod Bore Code			
		1	2	3	
		30.000-30.005mm	30.006-30.011mm	30.012-30.018mm	
Crankpin	A	26.993-27.000mm	E (Y)	D (G)	C (BR)
	B	26.987-26.994mm	D (G)	C (BR)	B (BL)
	C	26.982-26.988mm	C (BR)	B (BL)	A (B)

Bearing Metal thickness
A (B) : 1.502-1.505mm
B (BL) : 1.499-1.502mm
C (BR) : 1.496-1.499mm
D (G) : 1.493-1.496mm
E (Y) : 1.490-1.493mm

P = Pink

		Case Bore			
		1	2	3	
		31.000-31.005mm	31.006-31.011mm	31.012-31.018mm	
Main Journal Diameter Code	A	26.993-27.000mm	E (P)	D (Y)	C (G)
	B	26.987-26.994mm	D (Y)	C (G)	B (BR)
	C	26.982-26.988mm	C (G)	B (BR)	A (BL)

Bearing Metal thickness
A : 1.508-1.511mm
B : 1.505-1.508mm
C : 1.502-1.505mm
D : 1.499-1.502mm
E : 1.496-1.499mm



# CBR250R (J)

## Clutch AC Generator

Item	Standard	Standard	Limitation
Clutch	Clutch lever free play	10-20	-
	Clutch spring relaxed length	36	35
	Clutch disk thickness	2.9-3.0	2.6
	Clutch plate distortion	-	0.3
	Clutch outer guide bore	21.995-22.015	22.03
Oil pump drive sprocket bore		30.025-30.075	30.09
Oil pump drive gear collar	Bore	21.995-22.015	22.03
	Diameter	29.987-30.000	29.97
	Length	22.300-22.400	22.20
Main shaft diameter (clutch outer guide contact area)		21.980-21.990	21.97

## Transmission

Item	Standard	Standard	Limitation	
Transmission	Backlash		0.044-0.140	0.3
	Gear bore	M5	25.000-25.021	25.05
		M6	25.000-25.021	25.05
		C1	23.000-23.021	23.05
		C2	28.000-28.021	28.05
		C3	28.000-28.021	28.05
		C4	28.000-28.021	28.05
	Gear bush	M5 bore	21.985-22.006	22.07
		M5 diameter	24.959-24.980	24.92
		M6 diameter	24.959-24.980	24.92
		C1 diameter	22.959-22.980	22.92
		C1 bore	20.020-20.041	20.11
		C2 diameter	27.959-27.980	27.92
		C3 diameter	27.959-27.980	27.92
		C4 diameter	27.959-27.980	27.92
	Main shaft diameter	M5 area	21.963-21.977	21.93
		Clutch outer guide	21.980-21.990	22.20
	Counter shaft diameter	C1 area	19.987-20.000	19.77
	Gear and bush or shaft clearance	M5 – bush	-	0.10
		M5 bush-shaft	-	0.15
		M6 – bush	-	0.10
		C1 – bush	-	0.10
		C1 bush-shaft	-	0.15
		C2 – bush	-	0.10
		C3 – bush	-	0.10
		C4 – bush	-	0.10
	Shift Fork	Catch thickness	5.93-6.00	5.60
Bore		12.000-12.021	12.04	
Shift fork shaft	Diameter	11.960-11.971	11.90	

# CBR250R (J)

## Front wheel, Suspension and Steering

Item	Standard	Limitation
Front axle runout	-	0.2mm
Front wheel rim deflection	Radial	2.0mm
	Side	2.0mm
Front cushion spring relaxed length	303mm	297mm
Front fork pipe bent	-	0.2mm
Front fork oil capacity	Standard	362±2.5cc
	Fully compressed	95±6mm
Front fork air pressure	0-0.4kg/cm <sup>2</sup>	-

## Rear wheel, Brake, Suspension

Item	Standard	Limitation
Rear axle bent	-	0.2mm
Rear wheel rim deflection	Radial	2.0mm
	Side	2.0mm
Rear cushion damper compression	12.3-16.0kg	9.8kg
Rear cushion spring attachment length	162.3mm	-
Rear cushion spring relaxed length	172.1mm	168.7mm

## Brake System (Disk Brake)

Item	Standard	Standard	Limitation
Brake disk thickness		4.8-5.2	4.0
Brake disk deflection		-	3.0
Front master cylinder bore		11.000-11.043	11.055
Rear master cylinder bore		12.700-12.743	12.755
Front master piston diameter		10.957-10.984	10.945
Rear master piston diameter		12.657-12.684	12.645
Front caliper cylinder bore		27.00-27.05	27.06
Rear caliper cylinder bore		27.00-27.05	27.06
Front caliper piston diameter		26.918-26.968	26.91
Rear caliper piston diameter		26.918-26.968	26.91

# CBR250R (J)

## Battery Alternator

Item		Standard
Battery	Capacity	12V 6AH
	Charging current	0.6A (10H)
	Discharging voltage	13.0 – 13.2V (20°C)
Charging commencement rpm (Headlamp – ON low beam selected)		1,900 RPM
Regulate / Rectifier	Type	= non-contact point
	Regulated voltage	14.0-15.0V
AC alternator coil resistance		0.3-0.4 Ω (20°C)
AC alternator performance		18.5A/5.000rpm

## Ignition System

Item		Standard	
Spark plug		NGK	ND
		CR9EH-9	U27FER-9
		CR10EH-9	U31FER-9
Spark plug clearance		0.8-0.9mm	
Timing	" F " marking	23°C BTDC / 1.500rpm	
Ignition coil Resistance (20°C)	Primary coil		2.52 – 3.08 Ω
	Secondary coil	With high tension lead	11.7k – 14.3k Ω
		Without high tension lead	11.7k – 14.3k Ω
Pulse generator coil resistance (20°C)			315 – 385 Ω

## Self Starter System

Item	Standard	Standard	Limitation
Starter Motor	Brush spring tension	630-850g	-
	Brush length	11.00-11.05mm	4.5mm

## Lamp, Instruments and Switches

Item	Standard
Headlamp bulb	12V60/35W x 2
Front turn signal bulb	12V 18W
Rear turn signal bulb	12V / 5W
Stop / Tail lamp bulb	12V18 / 5W x 2
Pilot lamps (excluding the speed warning)	12V 1.7W x 4
Speed warning lamp	12V 3.4W
Tachometer, water temp gauge illuminator bulb	12V 1.7W x 2
Speedometer illuminator bulb	12V 1.7W x 2
Main fuse	30A
Headlamp sub fuse	15A
Other fuses	10A x 3

# CBR250R (J)

## Inspection Adjustment Service System

(Notes):

1. Inspection items include high speed operation.
2. (●) indicates the schedule set by regulation and (O) indicates manufacturer recommendation.
3. (☆) indicates security replacement.  
However, the schedule is set to ordinary vehicles. If the operating environment is significantly different, adjust the interval.
4. "High speed operation" is defined as approx 80km/h or higher.

Items to be serviced		Schedule				Notes			
		Before operation	After 1 month	Private					
				6 month	12 month				
Steering System	Steering handle	Free play / fitting				●			
		Operation					●		
	Steering wheel	Steering angle					●		
		Damage			●	●			
	Steering fork	Fork, spindle attachment			●	●			Steering stem
		Fork, spindle bearing looseness					●		Steering stem
Brake pedal	Free play and clearance between mounting bracket				●	●		Free play: Front brake lever edge 10~20mm Rear brake pedal 10~20mm	
	Pedal size and effectiveness		●						
	Brake effectiveness			O	●	●			
Hose /pipe	Leak, damage and attachment			O	●	●			
	Brake hose replacement							*	
Braking System	Reservoir tank	Quantity	●		●	●		Fluid level (min) Front: at least at the lowest level Rear: between min – max level	
		Function wear and damage					●		
	Master, wheel cylinder caliper	Master cylinder, wheel cylinder cup, dust seal and disk caliper rubber parts							* Biannual replacement
		Disk / pad clearance			O	●			
	Brake disk pad	Pad wear					●		Indicator type
		Disk wear / damage					●		Standard: Front 5.0mm Thickness: Rear 5.0mm Limitation: Front 4.0mm Rear 4.0mm
fluid	Brake fluid damage							* Annual	
Wheels	Tyre air pressure		●		●	●	1 person 2 people Tyre	Normal High speed Normal Type	Unit: Front 2.25 2.25 2.25 100-80 17-52H Rear 2.25 2.25 2.50 140-70 17-66H

# CBR250R (J)

Items to be serviced		Schedule				Notes		
		Before operation	1 month	Private				
				6 month	12 month			
Wheels	Wheel	Tyre crack	●		●	●		
		Tyre markings and wear	●		●	●	Tread depth - Front 0.8mm - Rear 0.8mm	
		Debris on tyres	●		●	●		
		Wheel nut / bolt			●	●	Axle nuts and holders Front axle holder, torque 1.8~2.5kg-m Front axle torque 5.5~6.5kg-m Rear axle nut torque 8.0~10.0kg-m	
		Rim, side ring and wheel disk damage				●	Wheel rim deflection at rim end Front wheel rim side 2.0mm or less radial 2.0mm " " Rear wheel rim..... side .2.0mm " " radial 2.0mm " "	
		Front wheel bearing fit				●		
		Rear wheel bearing fit				●		
Shock Absorber	Cushion spring	Damages				●	Cushion spring	
	Suspension arm	Joint fit and arm damage				●		
	Shock absorber	Oil leak and damage				●		
		Attachment fit					●	
Transmission	Clutch	Lever free play			●	●	Free play at lever end 10-20mm	
		Operation		○	●	●		
	transmission	Oil leak and quantity			●	●	Dipstick type between min-max.	
		Shift Lever fit					●	
	Chain and Sprocket	Chain tension			●	●	When using sidestand, between front / rear sprockets: 15~25mm	
		Sprocket attachment and wear					●	
Electrical system	Ignition	Spark plug condition			●	●	Plug gap: 0.8 – 0.9mm	
	Battery	Terminal connection				●		
	Wiring	Connectors fit and damage				●		
Powerplant	Main body	Starting and noise			●	●		
		Low speed and acceleration			●	●	Idling rpm 1.500 ± 100rpm	
		Exhaust condition			●	●		
		Air cleaner element						Every 20,000km
		Valve clearance					●	Inlet (cooled): 0.13 – 0.19mm Exhaust (cooled): 0.20 – 0.26mm

# CBR250R (J)

Items to be serviced		Schedule				Notes	
		Before operation	After 1 month	Private			
				6 month	12 month		
Power plant	Lubrication system	Oil quantity and quality			●	●	Oil level Dipstick – between min – max lines
		Oil leak			●	●	
		Oil quantity	●				
		Engine oil change		○			Initial 1.000km, every 6000km after that
		Oil filter change					Initial 13.000km, every 12,000km after that
	Fuel system	Fuel leak			●	●	
		Carburetor linkage				●	
		Throttle valve and choke valve				●	
		Fuel filter				●	
		Fuel quantity	●				
	Cooling system	Fuel hose replacement					Every four years
		Coolant level	●		●	●	Reservoir tank between min-max lines.
		Coolant leak	●			●	
		Radiator cap function				●	0.95-1.25kg/cm <sup>2</sup> valve opening pressure
Coolant change						Blannual	
Lighting and turn signals	Operation			●	●		
	Brightness, flashing, dirt and damage	●					
Horn and lock	Operation				●		
Rear view mirror	Vision	●				Rearview mirrors only	
Reflector, registration number plate	Dirt and damage	●					
Instruments	Operation				●		
Exhaust pipe & muffler	Attachment and damage				●		
	Muffler function				●		
Chassis & Body	Loose fit and damage				●		
Defects discovered on previous day	Inspect the specific item	●					
Other	Grease to the parts on chassis			●	●		

# CBR250R (J)

## Wheel nut / bolt tightness

Inspect the front axle bolt and rear axle nut for tightness. Inspect the bottom case pinch bolt for tightness. Tighten as required.

### Torque:

Front axle	6.0kg-m
Bottom case pinch bolt	2.2kg-m
Rear axle	9.0kg-m

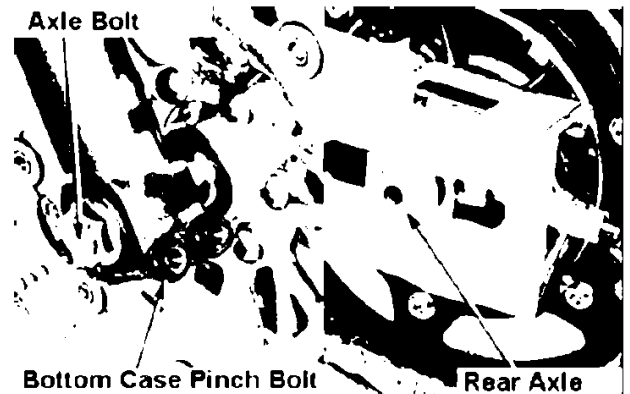

## Air cleaner element change

Remove the fuel tank (22-19).  
Remove screws and detach air cleaner case cover.

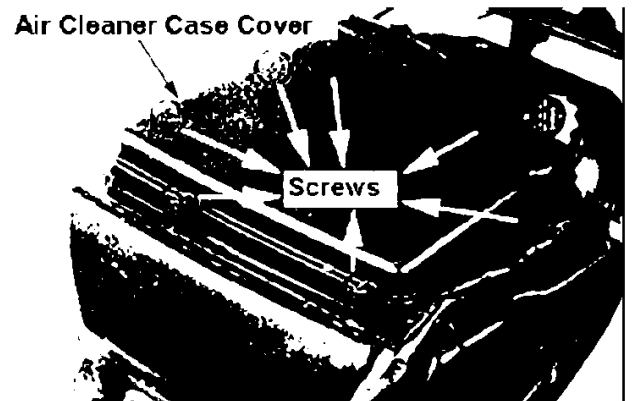

Inspect the element for dirt and damage.  
Replace if dirt or damage is significant.

- Do not clean filter papers as they contain oil (viscous type).
- If the vehicle is operated under severe conditions, replace earlier than recommended.

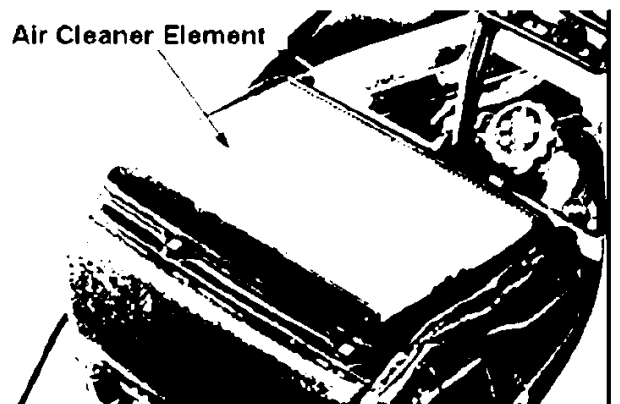

Recommended interval: every 20,000km

Reverse the above procedure for attachment.

## Headlamp

Rotate the vertical and horizontal adjusting screws to adjust the lamp direction.

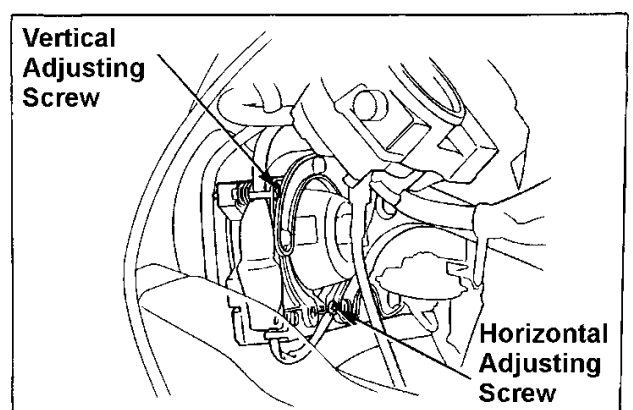

# CBR250R (J)

## Side Stand

Inspect the side stand rubber for wear. If the rubber is worn to the limit line, replace it.

Check the operation of the side stand. When the stand stops at the first notch and the rubber contacts ground, the stand moves forward and supports the body. When the body is stood up and the stand rubber comes off from the ground, the stand moves to the first notch and it should smoothly be retracted.

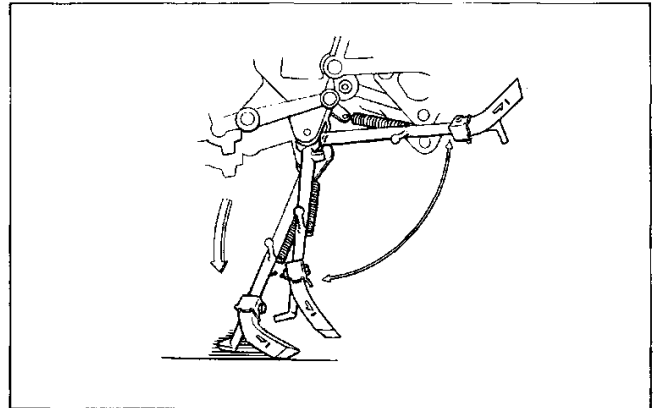

If the above operation is not smooth, disassemble and inspect the sidestand. Remove the return spring at the retracted position. Remove the pivot bolt and disassemble the side stand. Inspect the pivot bore, pivot collar and dust seals for wear and damage. After the inspection, apply grease to the pivot and assembly the stand.

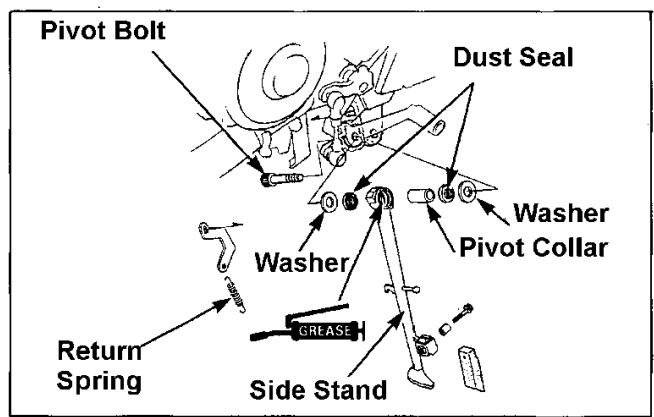

- Attach dust seals so as to have springs facing outward.
- Attach the side stand after confirming the dust seal spring is attached.

After the attachment, check its operation.

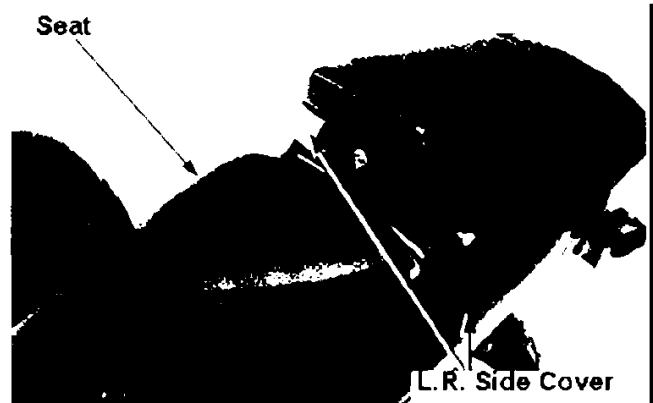

## Fuel System

### Fuel tank detachment / attachment

Remove bolts and detach the seat. Detach left and right side covers (22-30).

Turn the fuel cock "OFF".

Remove three bolts.

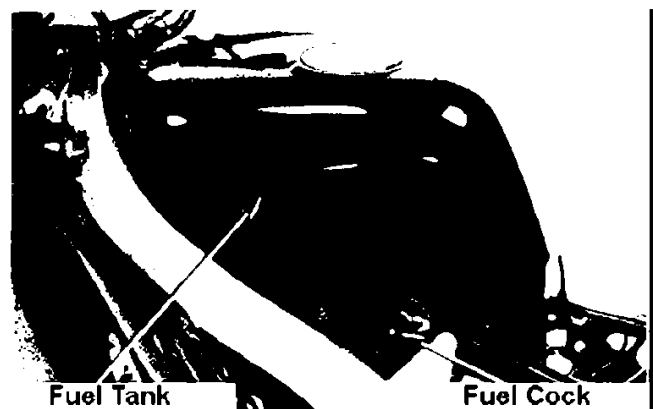



# CBR250R (J)

Lift the rear of the tank and disconnect the fuel tube.

Detach the fuel tank.

Reverse the procedure for attachment.

After the attachment, check for fuel leak.

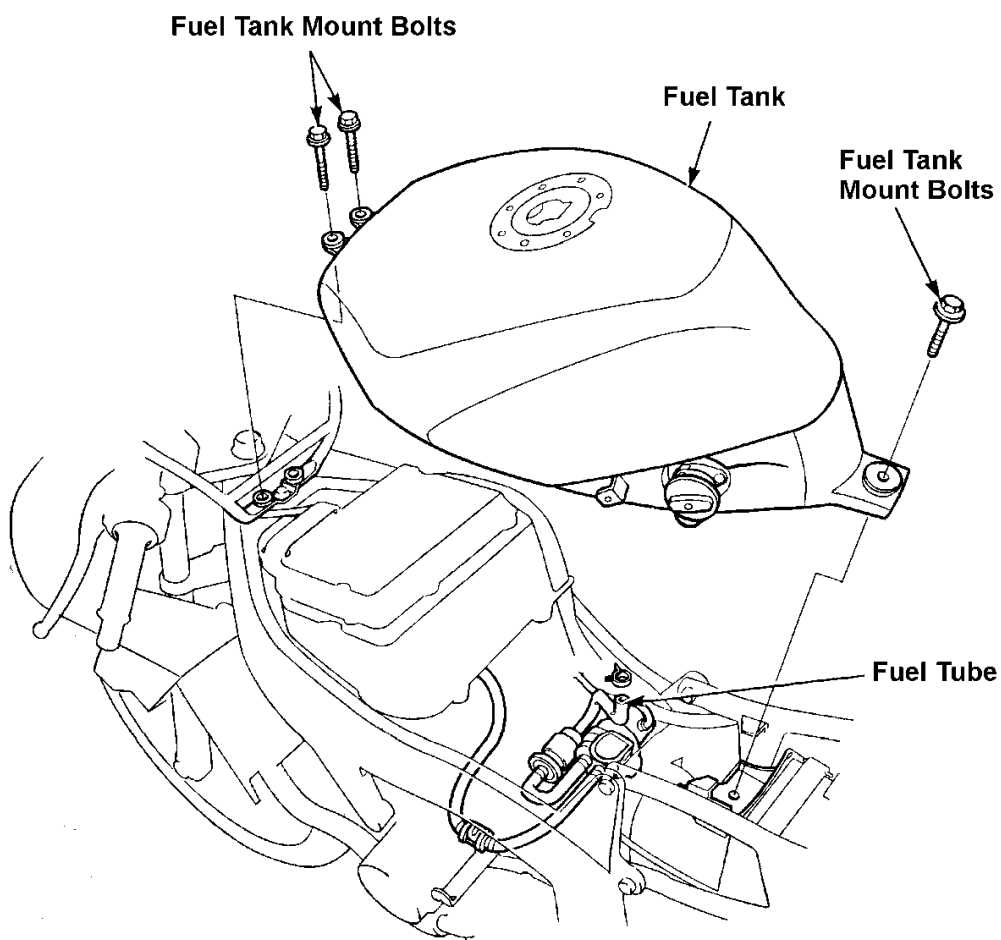
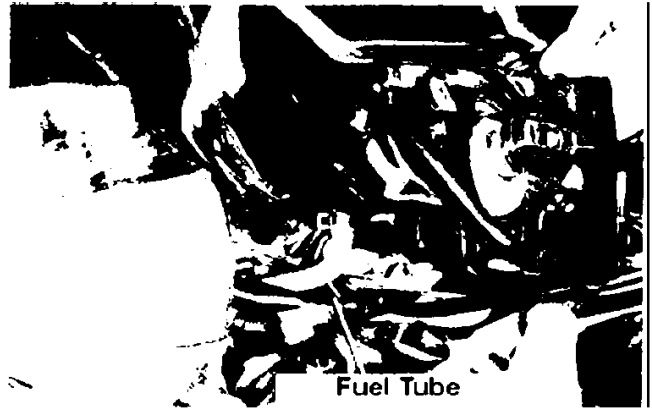

## Air cleaner case attachment / detachment

Remove the seat and fuel tank (22-19).

Detach the air cleaner element (22-18).

If the air cleaner case is not to be disassembled, the air cleaner does not have to be detached.



# CBR250R (J)

Detach the main wire harness from the clamp on the air cleaner case.  
Remove air cleaner case attachment screws and detach the upper case.

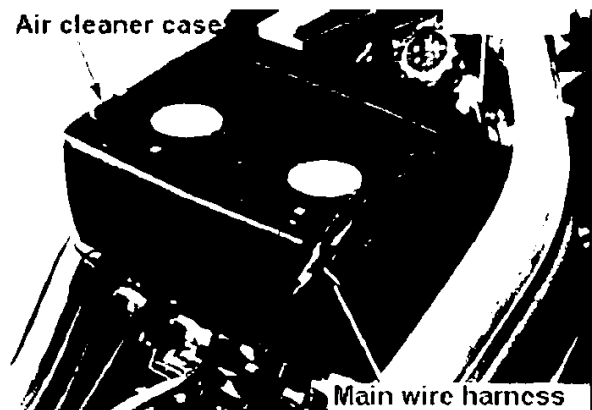

Remove bolts and screws to detach the lower case.

Reverse the above procedure for attachment.

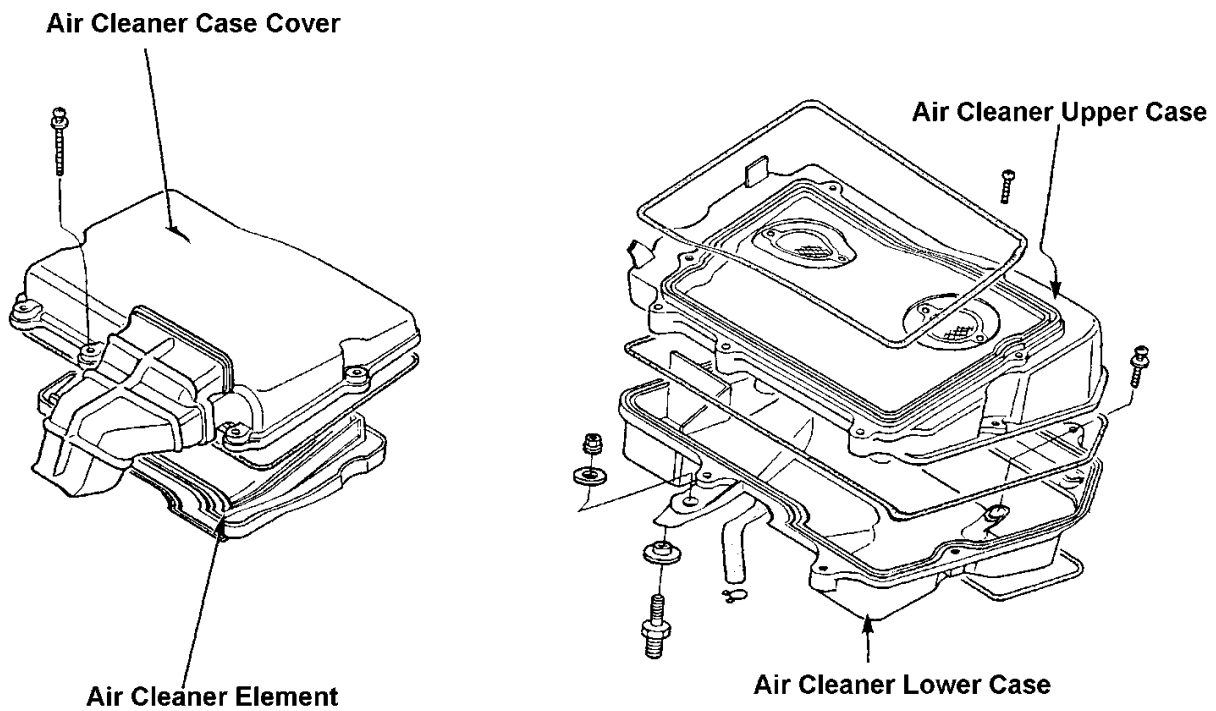

# CBR250R (J)

## Carburettor synchronisation adjustment

Adjust after warming up the engine.

Place the fuel tank at the rear while the tube is connected.

Remove plugs and washers from each cylinder head intake ports.

Connect the vacuum gauge adaptor to each plug hole.

Connect rubber tube of the vacuum gauge to the adaptor.

Start the engine and set up the idling rpm.

Idling rpm:  $1500 \pm 100$ rpm

Measure the vacuum difference between the cylinders.

Vacuum difference:  $\pm 20$ mmHg

Measuring tool

Vacuum gauge: 07404-0020000

Adjust in the following manner if the difference is exceeding the limit.

- 1) Check the position of pilot screws on the carburettor.
- 2) Adjust synchronisation by rotating the adjusting screw.

Use No. 3 carburettor as a standard.

\* #1, 2 carburettor synchronisation >

Detach air cleaner case cover.

Rotate the adjust screw from front of the carburetor.

\* #4 carburettor synchronisation >

Rotate the adjust screw from behind the air cleaner case.

After the adjustment, check the synchronisation and set to idle.

Attach each part by reversing the detachment procedure.

## Engine Mount / Dismount

<Drive sprocket attachment / detachment>

Remove three bolts and detach the drive

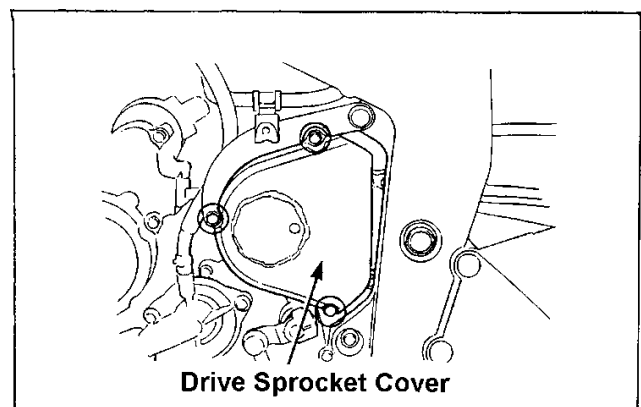
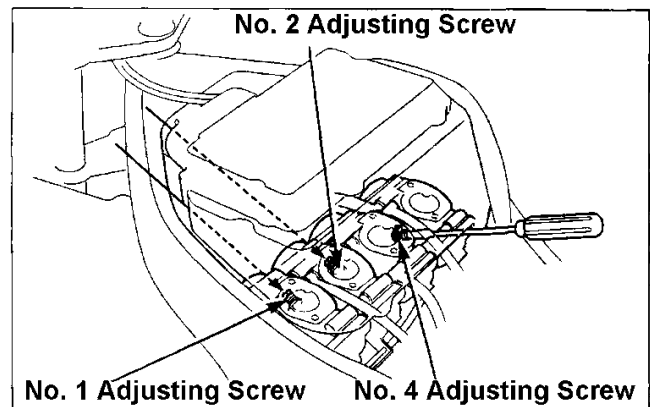
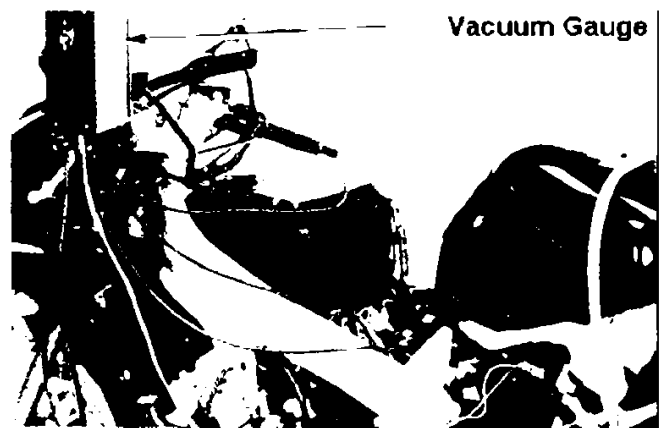
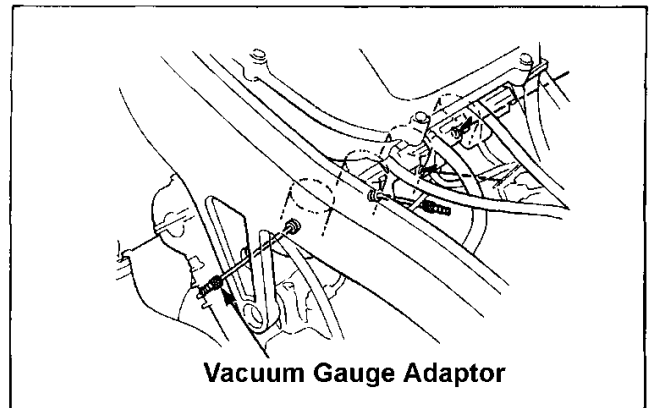

# CBR250R (J)

sprocket cover.

Loosen the rear axle nut, lock nut and chain adjusting nut and ease the tension of the drive chain.

Remove the bolt and detach the drive sprocket and the cushion rubber.

- **Change Pedal Detachment**

Remove the bolt and pull out the change pedal arm from the shaft.

Remove the bolt and detach the pedal.

## Engine Attachment

Reverse the detachment procedure.

- When attaching the change pedal, align punched marks on the change shaft and the change arm.
- After installing the drive sprocket, set the cushion rubber and the set plate.

### Torque:

Top engine mount bolt	4.5 ~ 5.5kg-m
Rear upper engine mount bolt	4.5 ~ 5.5kg-m
Rear lower engine mount bolt	4.5 ~ 5.5kg-m
Change arm bolt	1.4 ~ 1.8kg-m
Engine hanger bracket	3.5 ~ 4.5kg-m

## Cylinder Head, Valve

### Cylinder head cover attachment / detachment

Detach the lower cowl (22-31).

Detach the radiator (5-3).

Disconnect the breather tube from the cylinder head cover.

Remove plug caps.

Remove bolts to detach cylinder head covers.

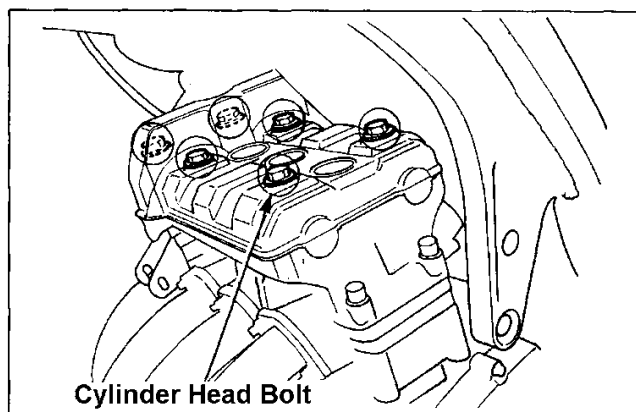
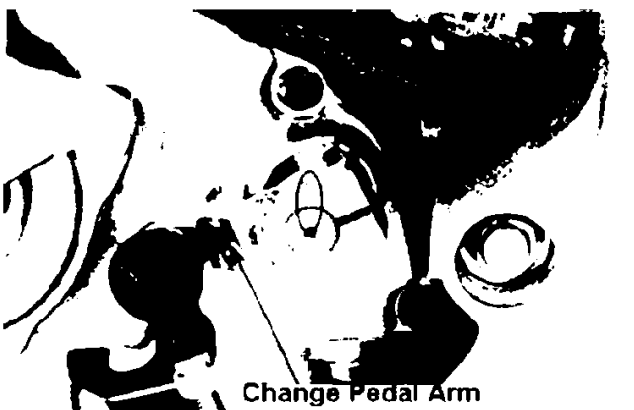
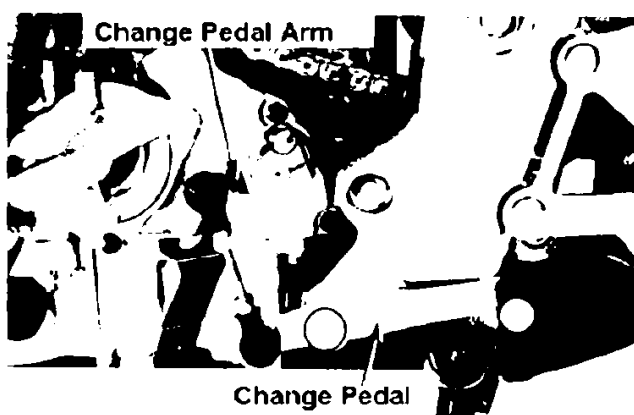
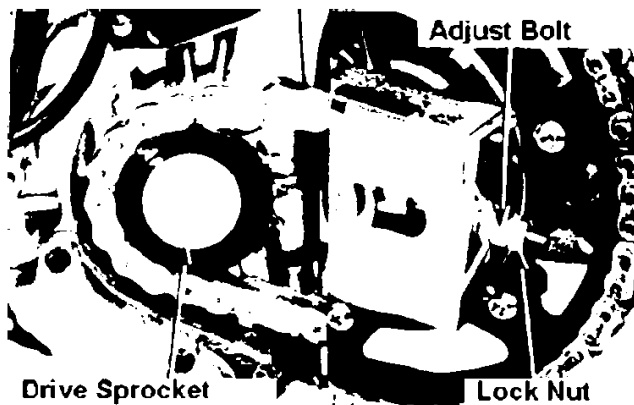

# CBR250R (J)

Reverse the procedure for the attachment.

## Front Wheel Attachment / Detachment

### Detachment

Remove the screw and disconnect the speedometer cable.

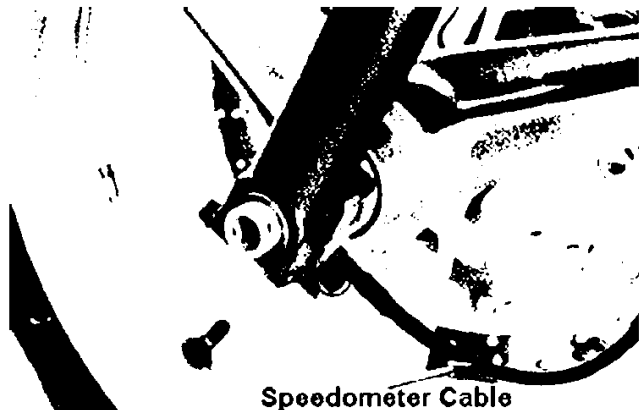

Remove the axle bolt.  
Loosen four bottom case pinch bolts.

Pull the axle shaft towards the left and detach.

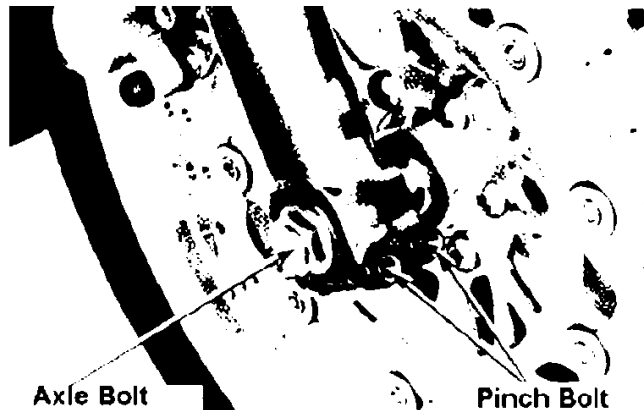

### Disc Plate detachment

Remove socket bolts and detach the disk plate.

Do not disassemble after detaching the disc plate.

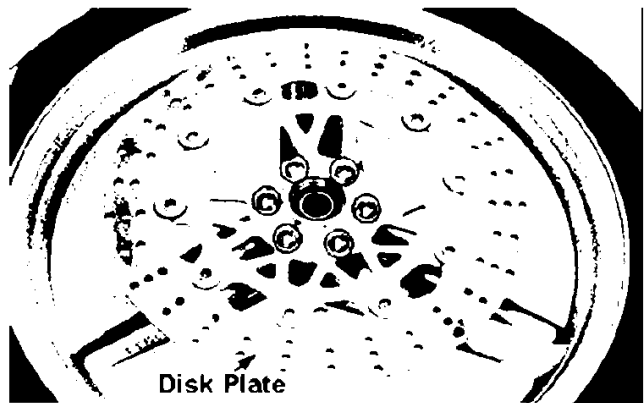

### Attachment

Widen the brake pads separation with the screwdriver.

Align the speedometer gear box stopper with the back of the left fork bottom case stopper.

Install the axle shaft from left hand side.

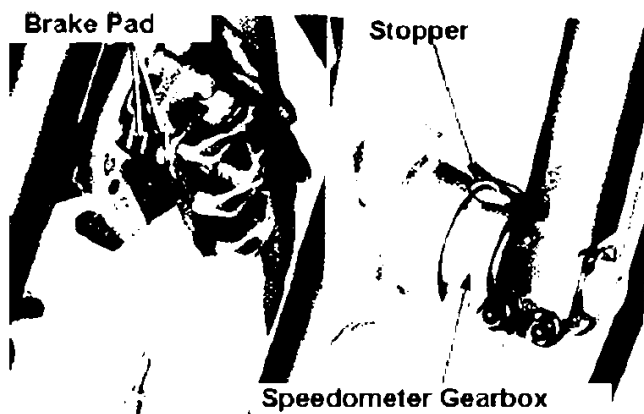

# CBR250R (J)

Tighten the axle bolt.  
Torque: 6.0kg-m

Tighten the bottom case pinch bolt.  
Torque: 2.2kg-m

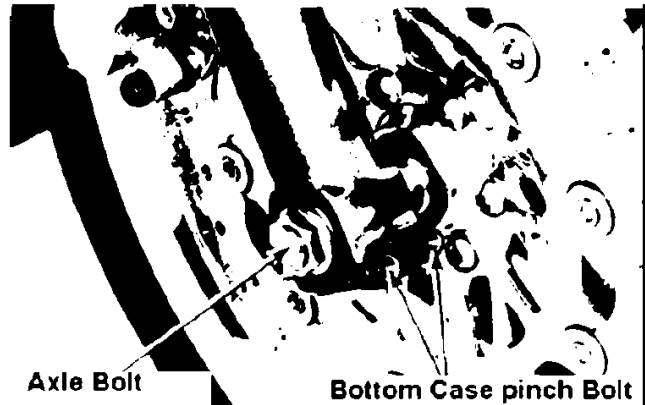

Connect the speedometer cable.



## Rear Wheel, Suspension

### Rear cushion

#### Detachment

Support the frame and lift the rear wheel.  
Detach the left side cover.  
Remove the conrod bolt (cushion arm side).  
Remove the rear cushion lower bolt.

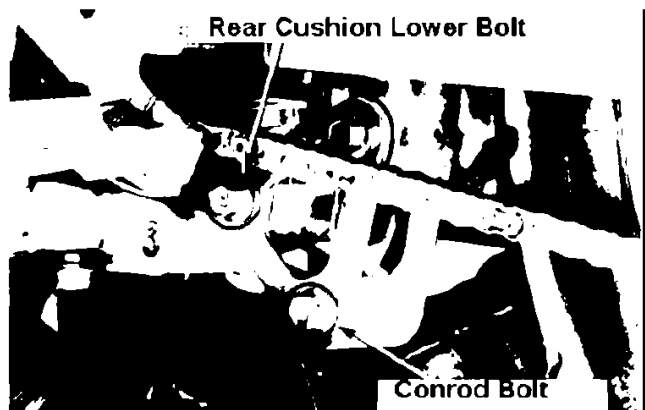

Remove the rear cushion upper bolt and detach the rear cushion downwards.

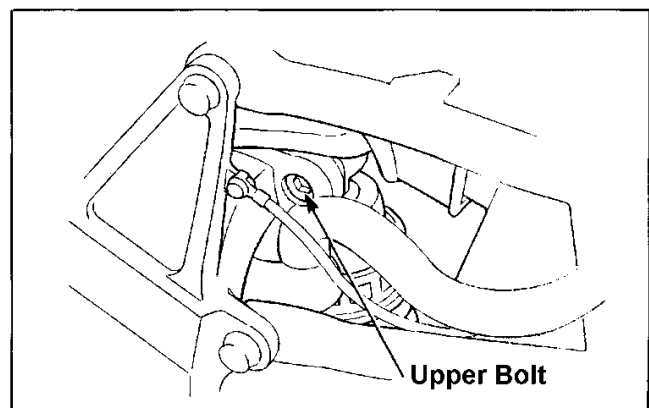

# CBR250R (J)

## • Assembly/Disassembly

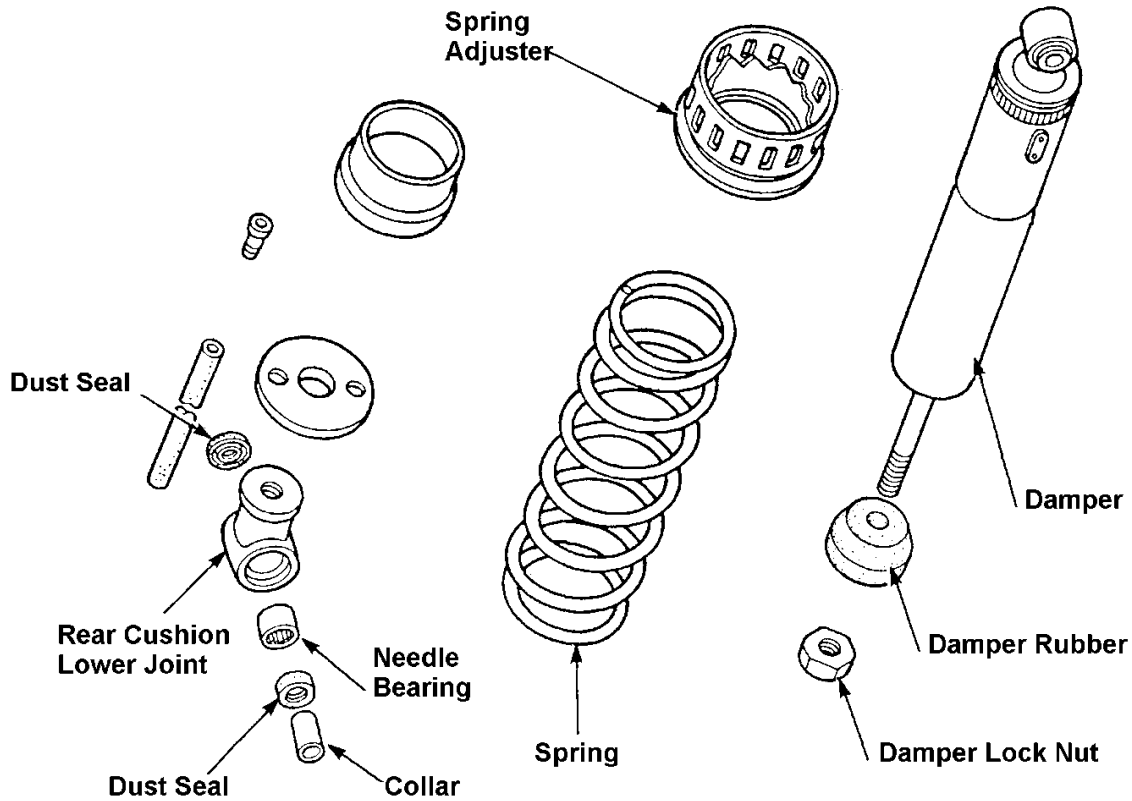

### Needle bearing replacement

Remove dust seals and the collar.  
By using hydraulic press machine, remove the needle bearing from the rear cushion.

Exc. tool

Bushdriver Assy 07GMD-KT80100

Install the new needle bearing to the rear cushion by using the press machine.

Exc. tool

Bushdriver Assy 07GMD-KT80100

After attaching it, apply grease to the bearing.  
Install dust seals and the collar.

### Attachment

Reverse the detachment procedure.

Tighten the rear cushion upper mount bolt after setting the lower mount bolt.

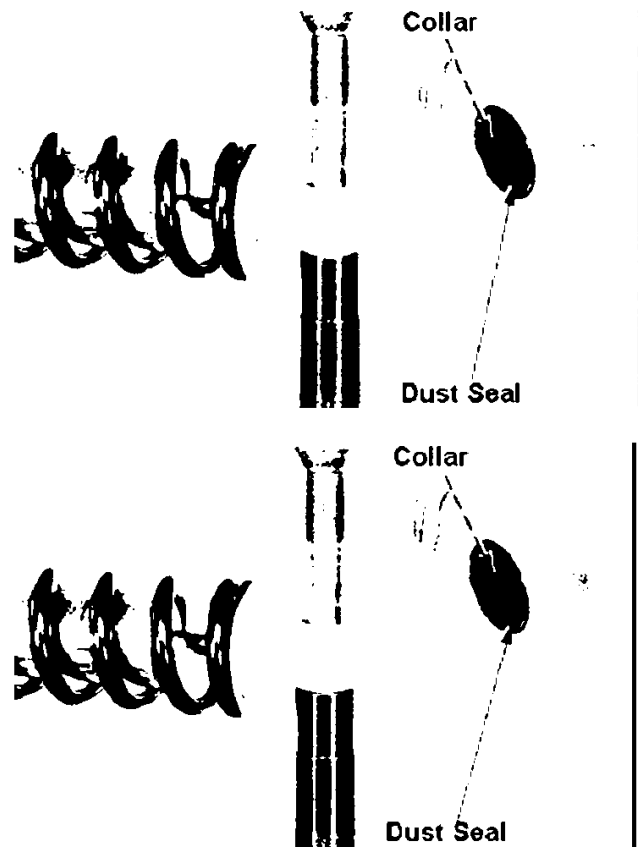

# CBR250R (J)

## Suspension linkage

### Detachment

Loosen the rear cushion upper mount bolt prior to detaching the suspension linkage.

Remove conrod bolts (frame side and the cushion arm side) and detach the cushion conrod.

Rear Cushion Lower Mount Bolt

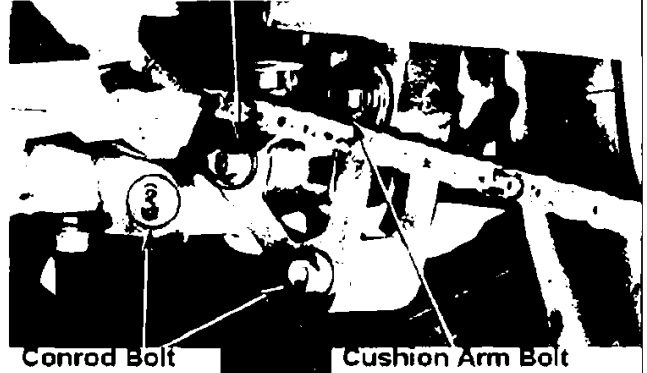

Remove the rear cushion lower bolt and the cushion arm bolt and detach the cushion arm.

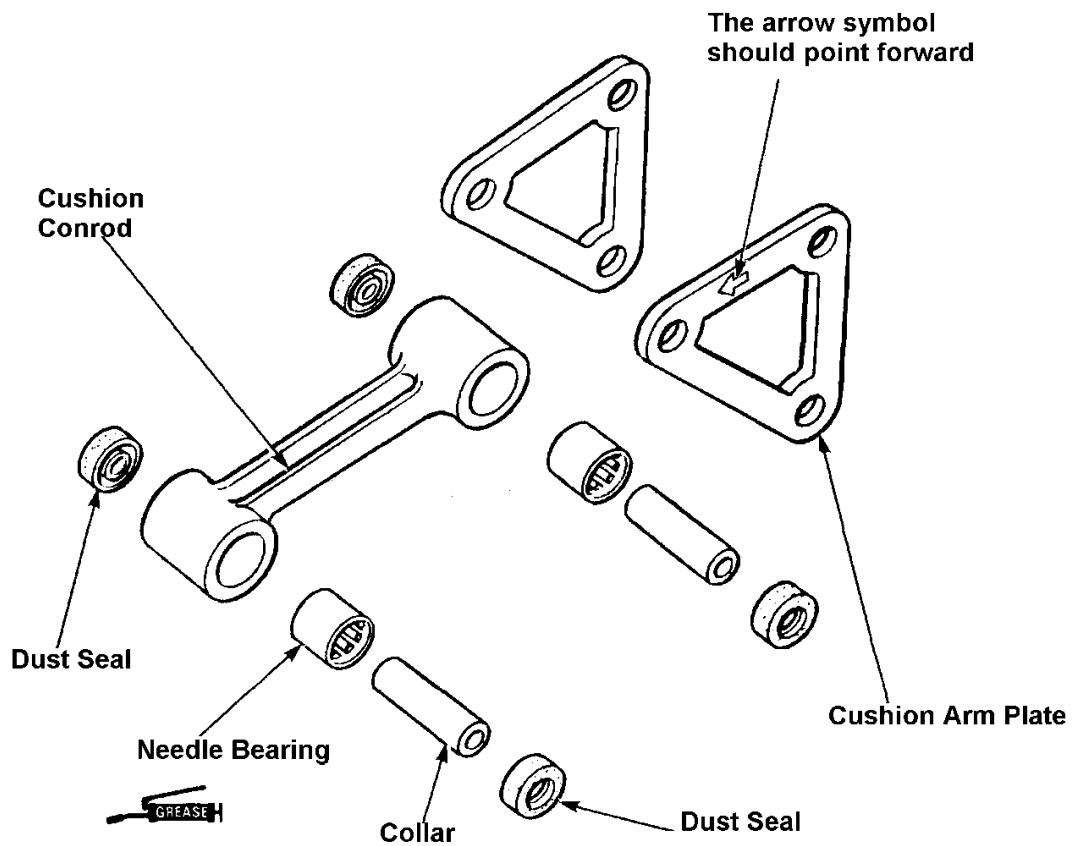

### Needle bearing replacement

Remove dust seals and collars.  
Detach the needle bearings from the conrod by using a hydraulic press machine.

Exc. tool

Bushdriver Assy 07GMD-KT80100

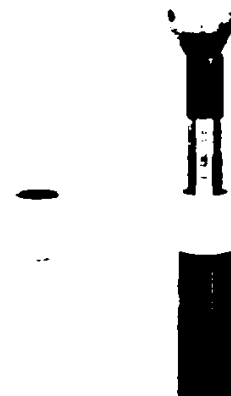



# CBR250R (J)

Install new needle bearing to the conrod by using a hydraulic press machine.  
After the attachment, apply grease to the bearing.  
Attach dust seals and collars.

Exc. tool

Bushdriver Assy 07GMD-KT80100

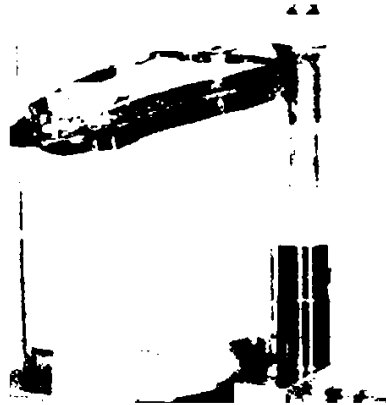

- **Rear Fork Assembly/Disassembly**

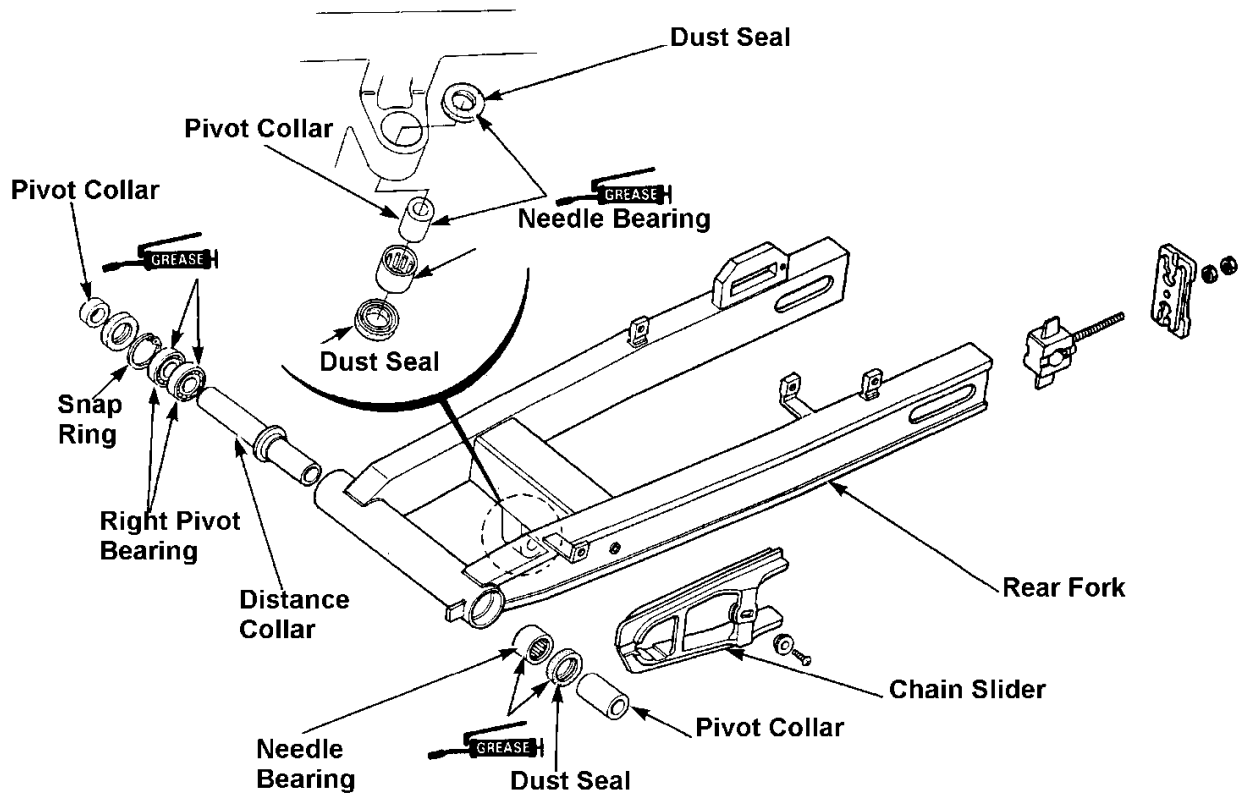

## Needle bearing replacement (suspension linkage side)

Remove dust seals and collars.  
Remove the needle bearings from a rear fork by using a press machine.

Exc. tool

Bushdriver Assy 07GMD-KT80100

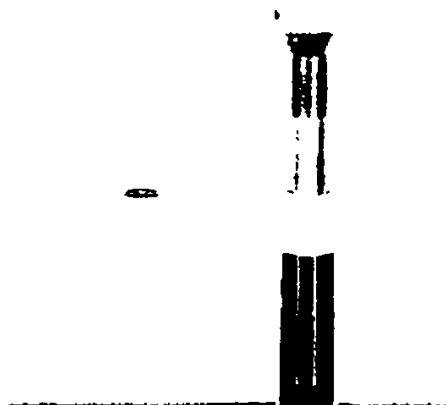

# CBR250R (J)

Install the new needle bearings to the rear fork by using the press machine.  
After installing them, apply grease to the bearings.

Install dust seals and collars.

Exc. tool

Bushdriver Assy 07GMD-KT80100

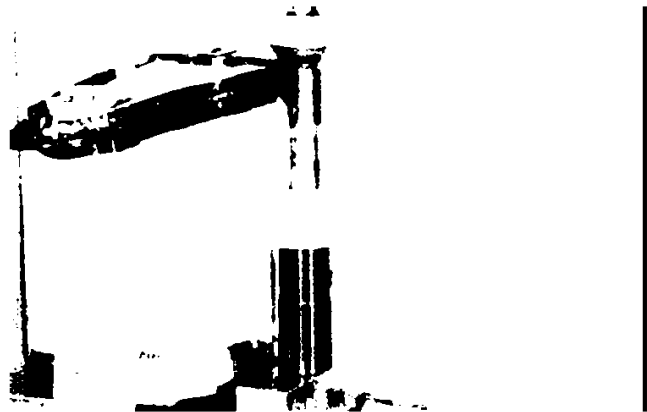

## Brake System (Disk Brake)

### Front brake pad change

Remove the pad pin plug and the hanger pin.  
Pull down the pad to remove.

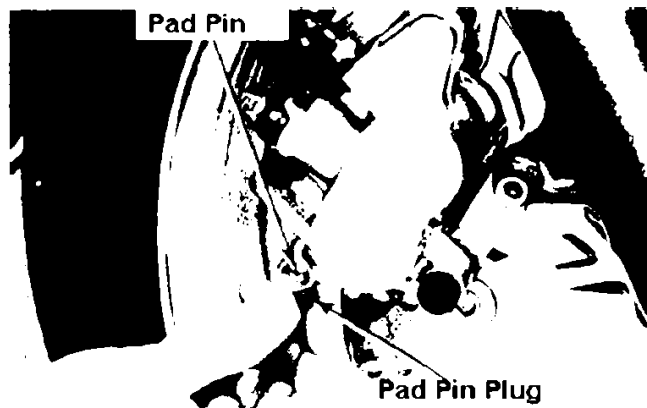

Attach the pad to the caliper by inserting the projection on the pad to the caliper dent.

- Always change brake pads in a pair.
- Check the pad spring and pad retainer are set firmly before installing pads.

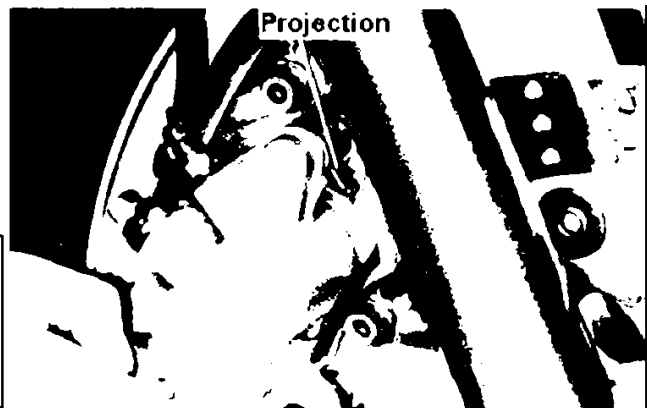

Push up the pad to compress the pad spring and install / tighten the hanger pin.

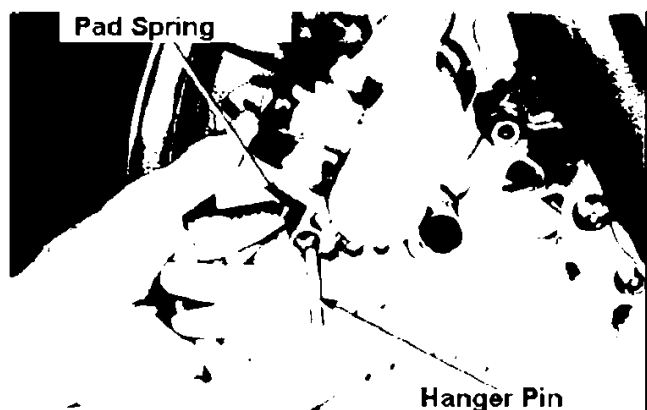

# CBR250R (J)

## Fairing

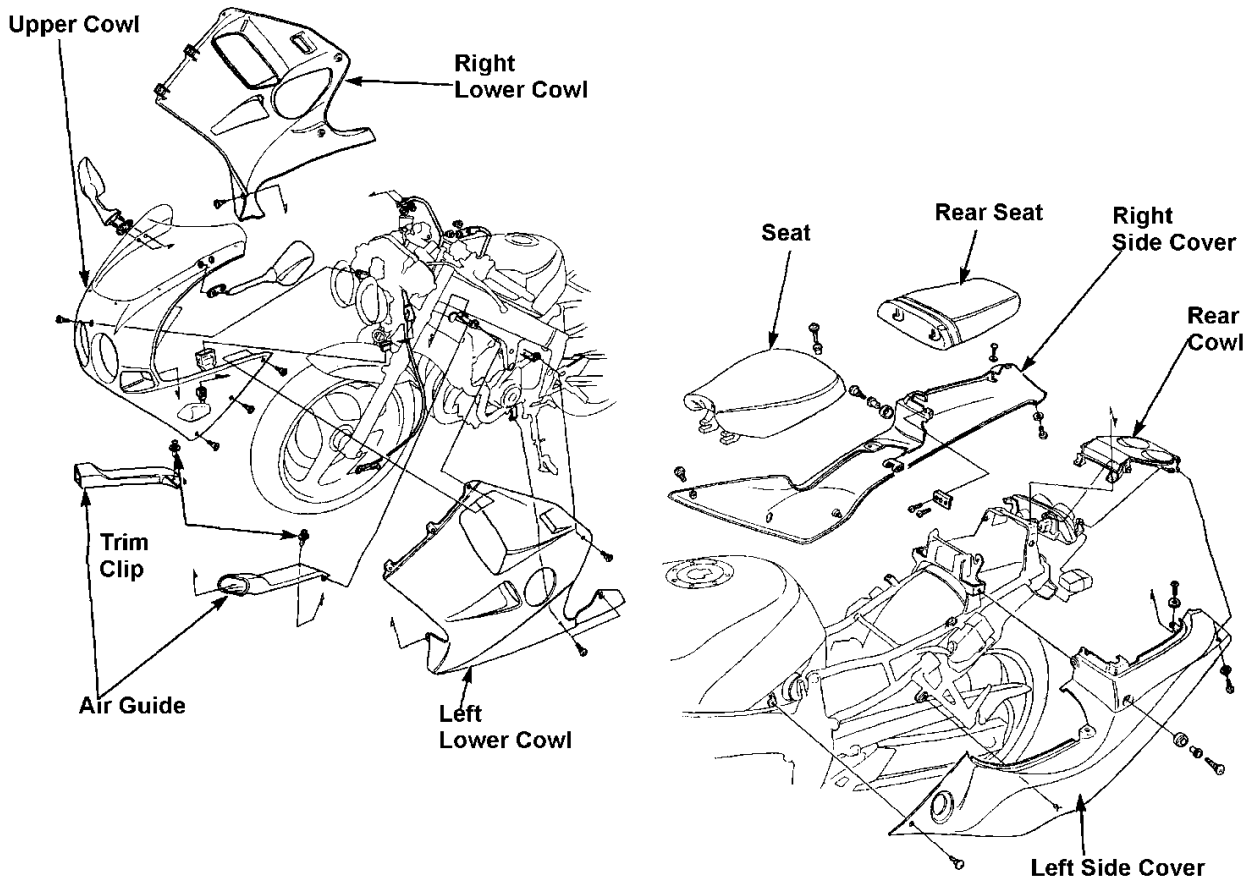

### Side cover attachment / detachment

Remove the seat and the rear seat.  
Remove screws underneath the rear cowl.

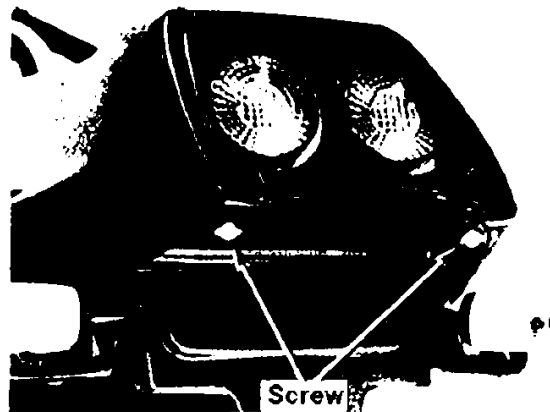

# CBR250R (J)

Remove joint screws and mount screws on lower part of the rear seat.  
Remove two side bolts and detach side covers.

When detaching side covers, do not snap hooks.

Reverse the procedure for the attachment.

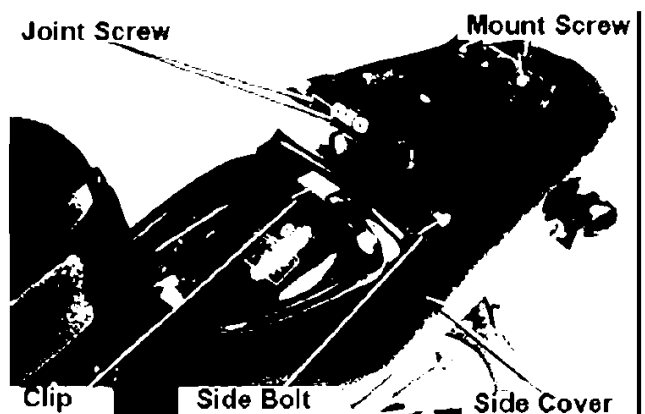

## Lower Cowl Attachment / Detachment

Remove the lower cowl joint bolt.  
Remove seven bolts to detach the left lower cowl.  
Remove six bolts to detach the right lower cowl.

Reverse the procedure for the attachment.



## Upper Cowl Attachment / Detachment

Detach lower cowls.  
Detach rearview mirrors.  
Remove the trim clip on the air guide to remove the air guide.

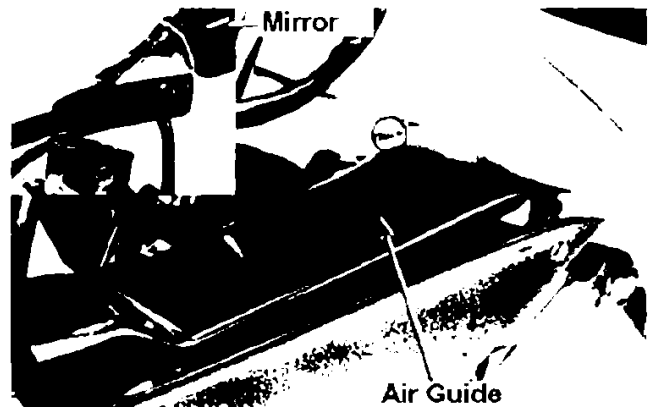

Disconnect left and right turn signal wire couplers.  
Detach 6P coupler clamp on left hand side and disconnect the coupler.

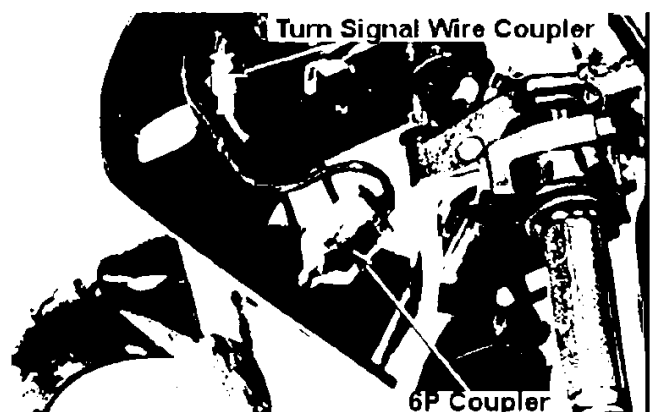

# CBR250R (J)

---

Remove the upper cowl mount screw to detach the upper cowl.

Reverse the procedure for the attachment.

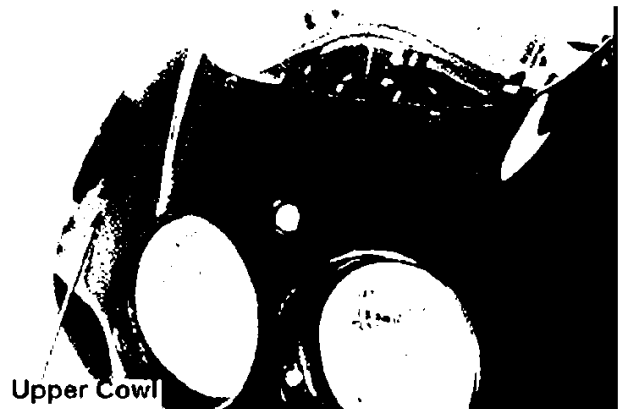

## Rear Cowl attachment / detachment

Remove side covers.  
Disconnect four hooks and detach the rear cowl.

Reverse the procedure for the attachment.

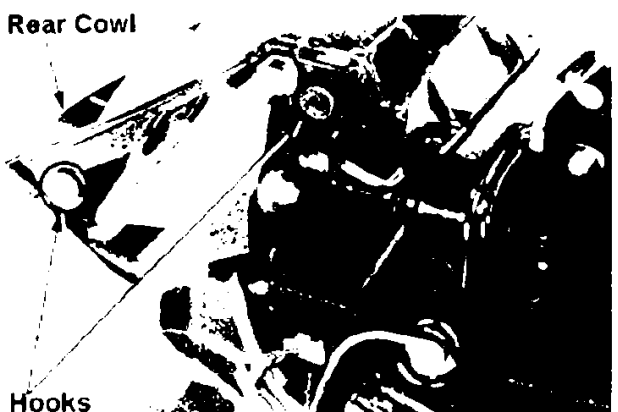

## Lamps, Instruments and Switches

### Headlamp case attachment/detachment

The headlamp can be detached individually.

Detach the upper cowl.  
By pushing the catch of the headlamp wire connector, disconnect it.  
Remove three bolts to detach the headlamp case.

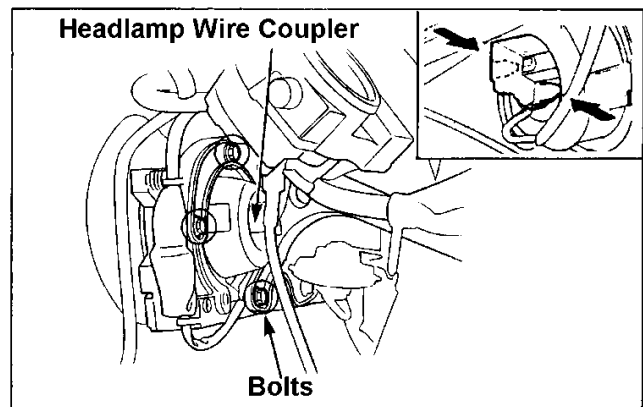

### Headlamp light bulb change

Detach the upper cowl (22-31).  
By pushing the catch of the headlamp wire connector, disconnect it.  
Remove the socket cover.

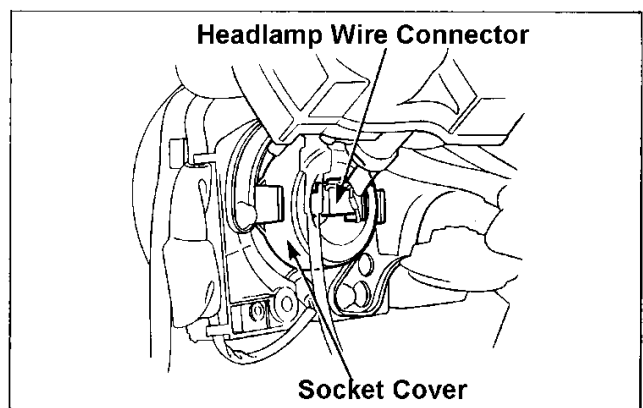

# CBR250R (J)

Detach the bulb socket and remove the bulb.  
Reverse the procedure for the attachment.

Place the socket cover so as to have an  
"UP" marking at the top.

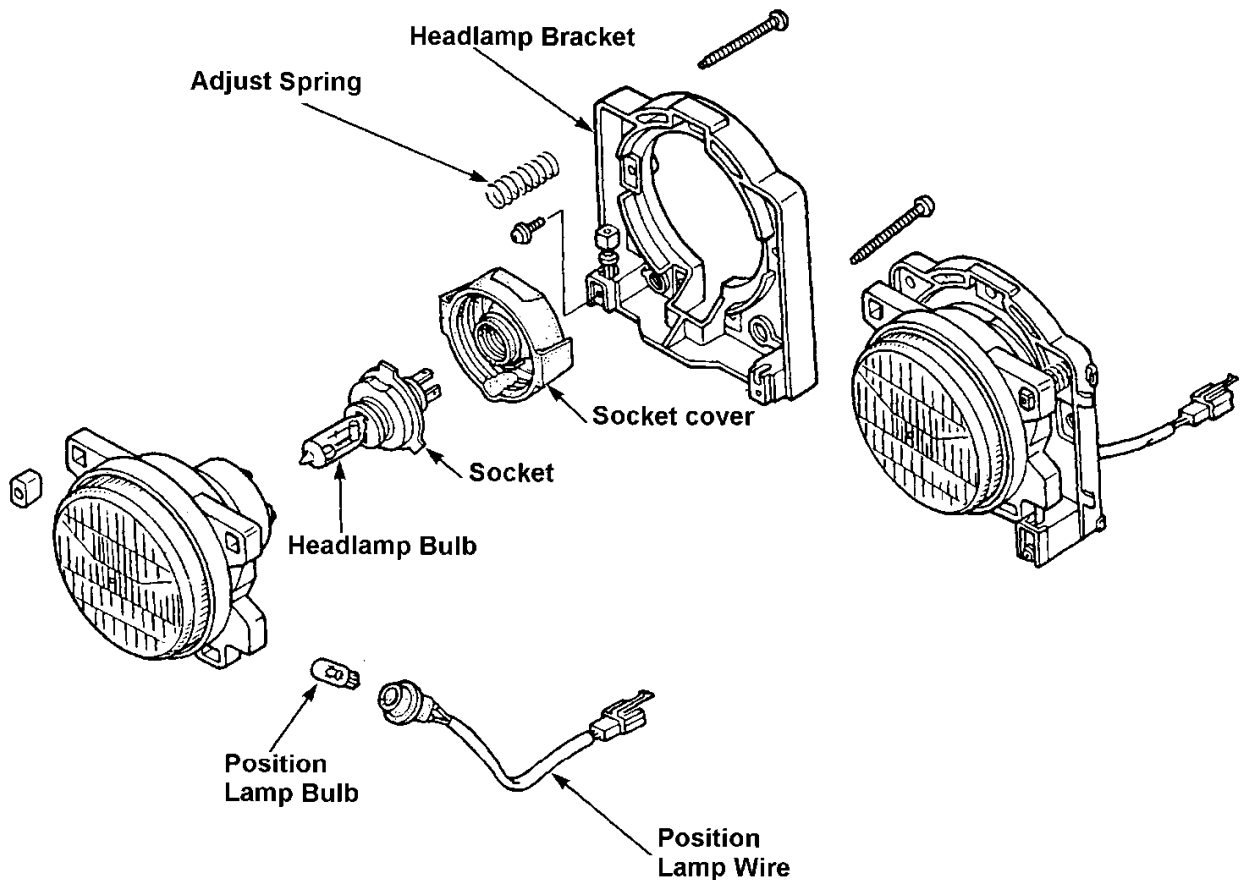
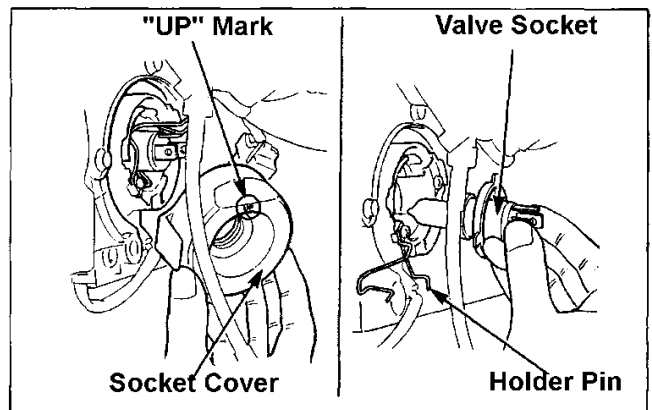

## Tail lamp bulb change

Detach the rear seat.  
Turn the bulb socket counter clockwise and pull it out.  
Remove the bulb.

Reverse the procedure for the attachment.



# CBR250R (J)

## Instruments attachment / detachment

Disconnect the speedometer cable.

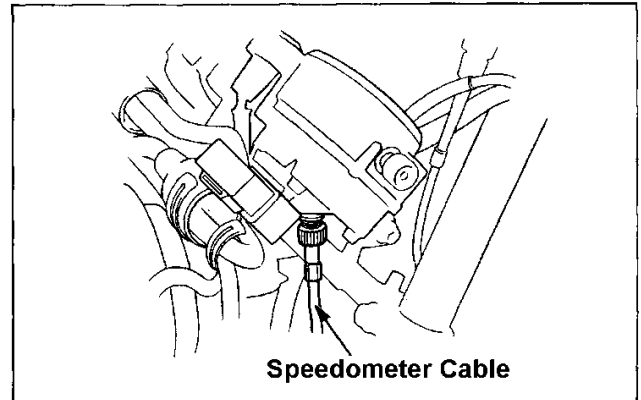

Disconnect the right air guide (22-31).  
Disconnect instrument wire couplers.  
Remove instrument mount bolt.

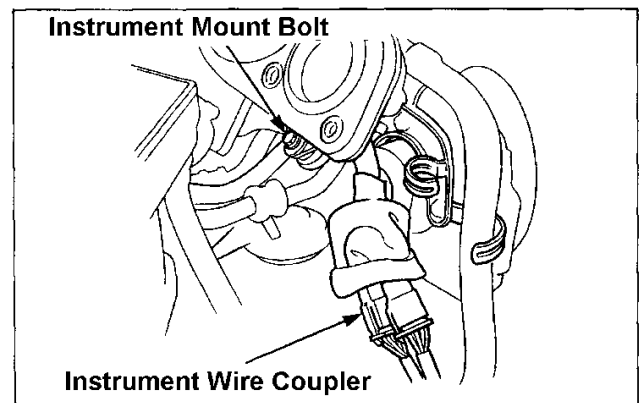

Instrument ASSY can be detached by rotating it clockwise around the speedometer and lifting it up.

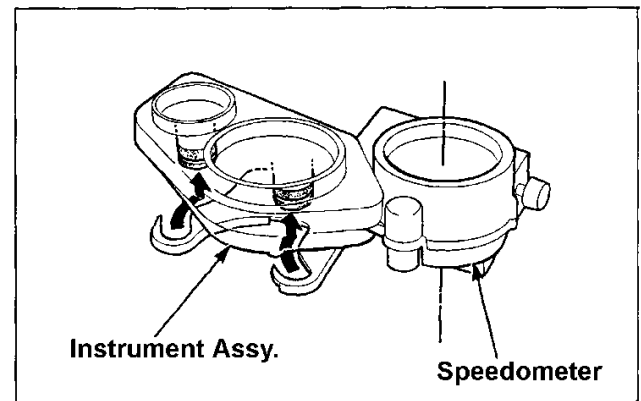

## Instrument bulb change

Detach the bulb socket and replace the bulb.

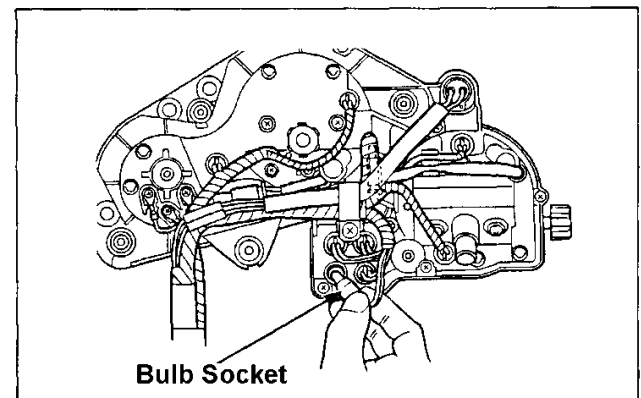

# CBR250R (J)

## Instruments disassembly

Remove screws and detach the instrument lower cover.

Remove connectors, bulb socket, trip meter reset knobs and individual instruments mount screws and disassemble them.

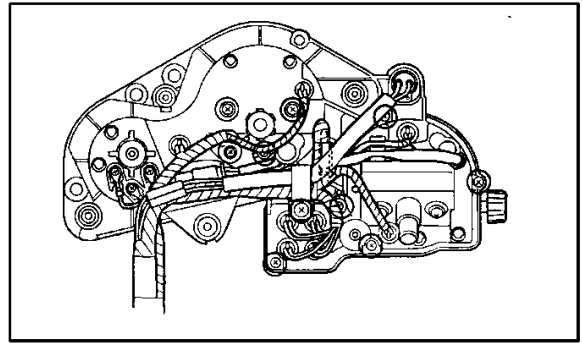

If you are removing screw tightening instrument wires, check the colour of the wires.

## Instruments assembly / attachment

Reverse the detachment / disassembly procedure.

- Correctly apply instrument wire harness.
- Firmly connect the wires with screws to corresponding terminals.
- When installing instruments, firmly attach four grommets to the stay.

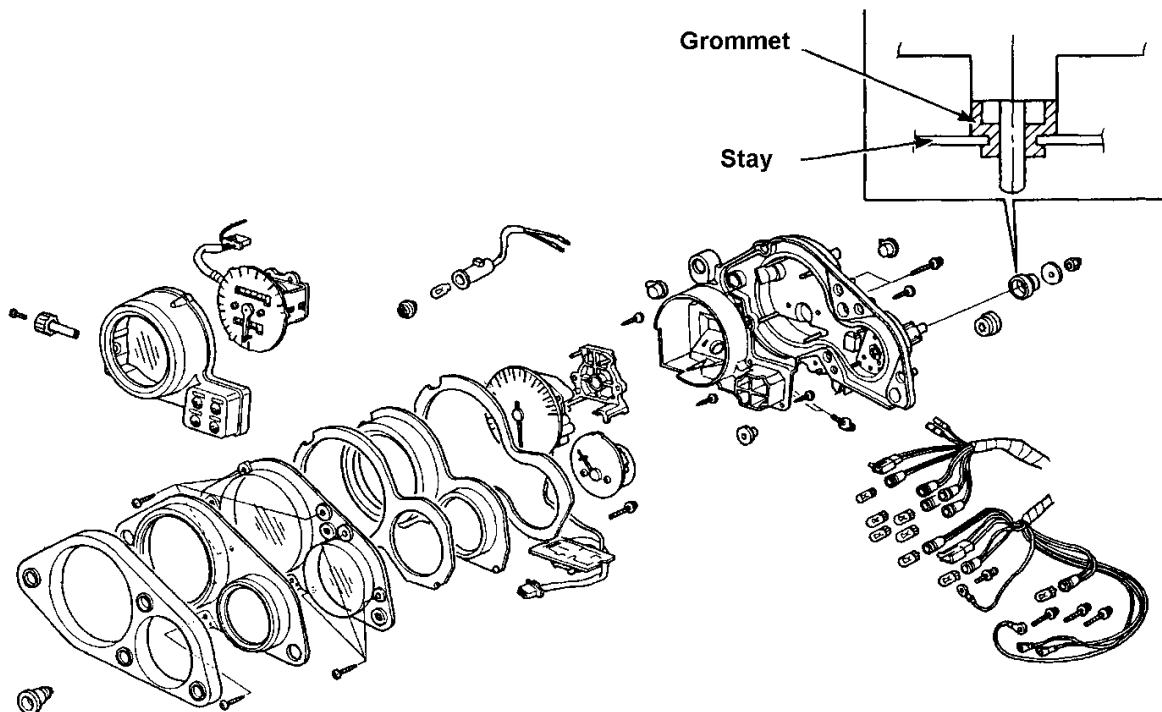



# CBR250R (J)

## Fuel pump system check

Top off the fuel tank (13l).

Detach the left lower cowl and the left side cover.

Disconnect the fuel tube (fuel pump ~ carburettor) from the carburettor and put the end to the container.

Turn the ignition "ON".

Disconnect the fuel cut relay wire coupler (Black/Blue – Black) and short circuit for 5 seconds.

From the amount of fuel coming out from the tube, calculate the fuel flow per minute.

**Standard: 1,800c.c. / min**

If there is a significant difference with the standard, inspect the fuel cut-off relay.

## Fuel pump inspection

Detach the fuel tank (22-19).

Disconnect the fuel pump wire coupler.

Disconnect the fuel tube from carburettor and pull the tube and the wire connector to the right side of the frame and re-attach the fuel tank (as shown in the figure).

Do not use pliers to disconnect the tube as they may damage the tube. A commercialised rubber tube remover may be an alternative.

Connect the battery to the fuel pump wire coupler and measure the fuel flow.

If the flow is far out of the standard, replace the fuel pump.

If the flow rate is ok, inspect the fuel cut off relay.

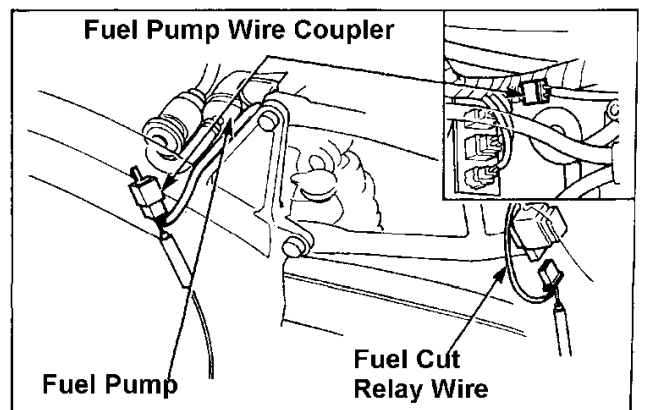
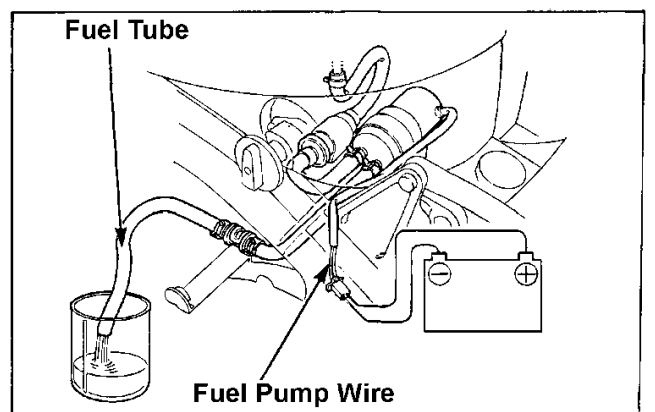
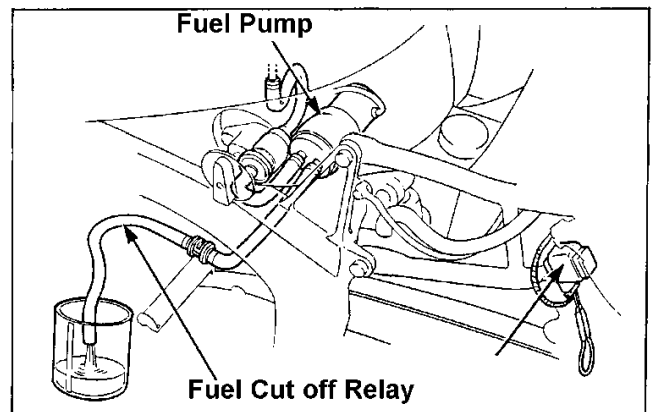

- Sparks may come out when connecting the battery. Exercise extreme caution so petrol does not catch fire.
- Check (+) (-) when connecting a battery. Reverse connection may end up with a fuel pump failure.

# CBR250R (J)

---

## Fuel cut relay inspection

Remove the fuel tank (22-19).

Disconnect the fuel cut relay wire coupler.

Disconnect the fuel pump wire coupler.

Check the continuity of Black / Blue wires between each coupler harness.

If no continuity, replace the wire harness.

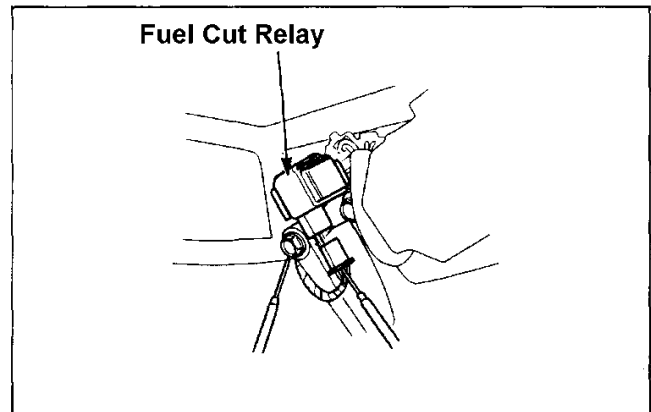

If there is no fault, conduct the following check on the fuel cut relay wire coupler (harness side).

Ignition "ON"

Measure the voltage between Black – ground earth.

Measure the voltage between Yellow - ground earth.

If the voltage indicate battery voltage, replace the fuel cut relay.

If there is no battery voltage, replace the wire harness.

**Table of Contents**

<b>Wiring Diagram .....</b>	<b>23-2</b>
<b>Circuit Wiring Diagram .....</b>	<b>23-3</b>

# CRBR250R (K)

- Wiring Diagram

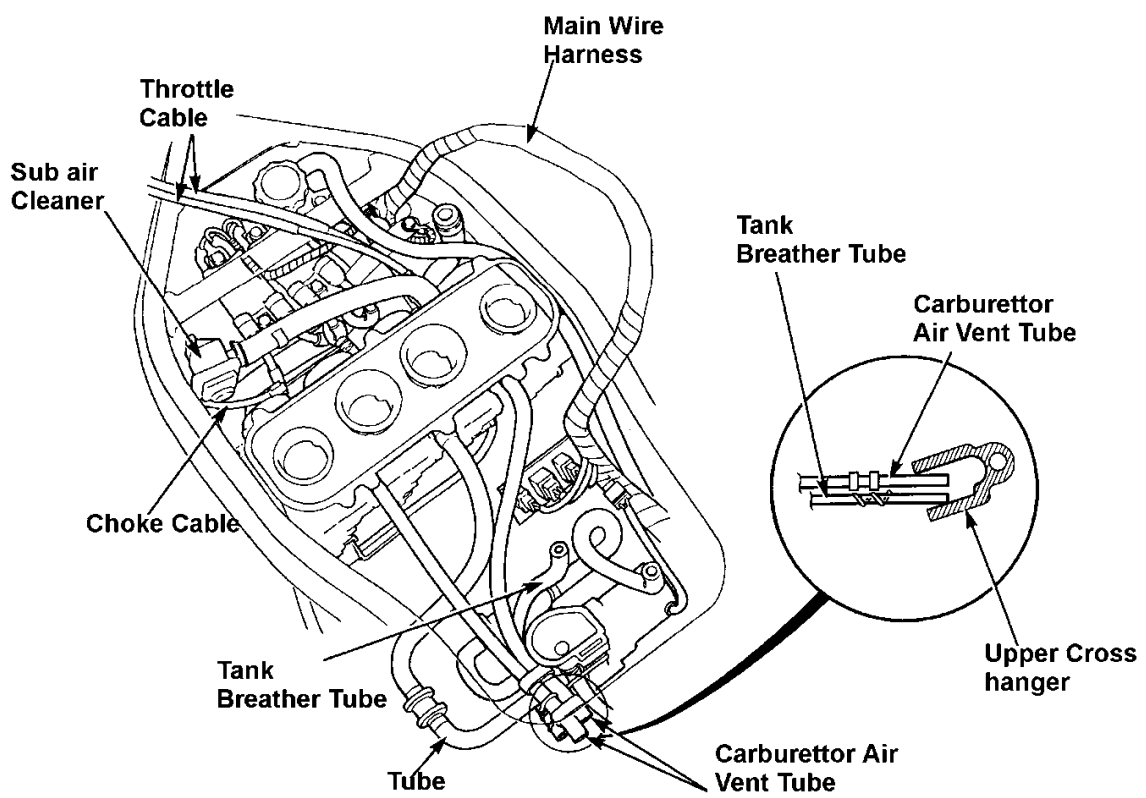
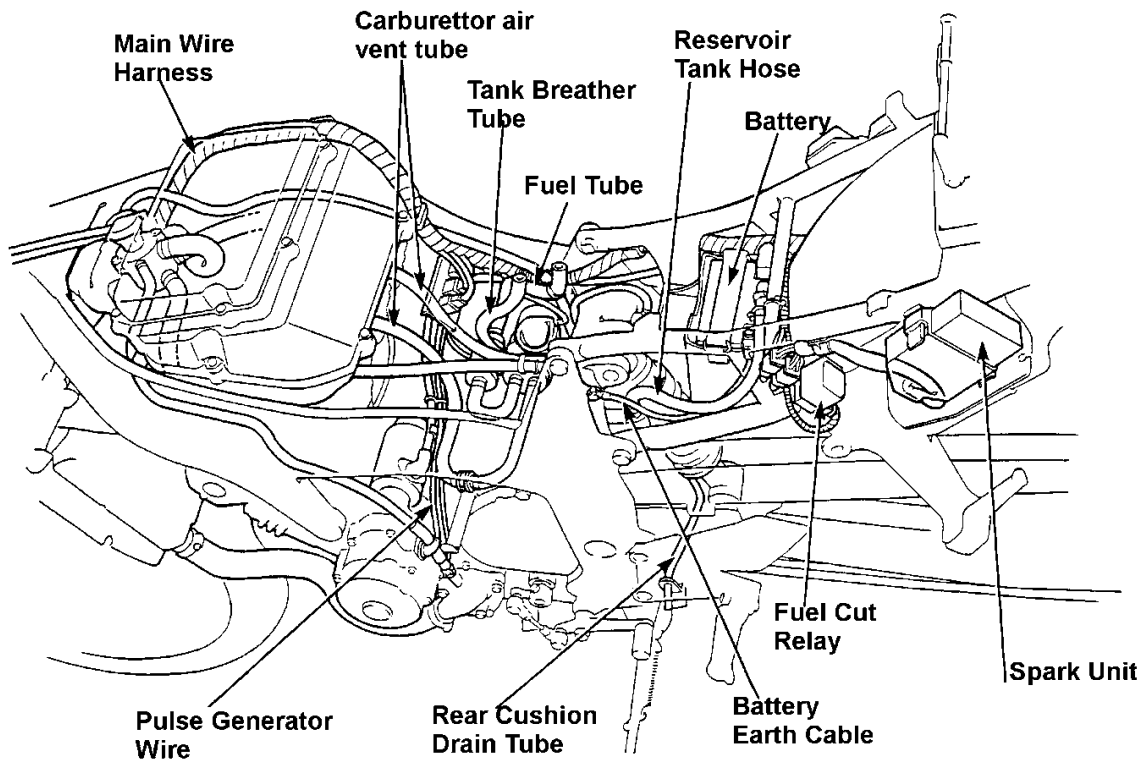

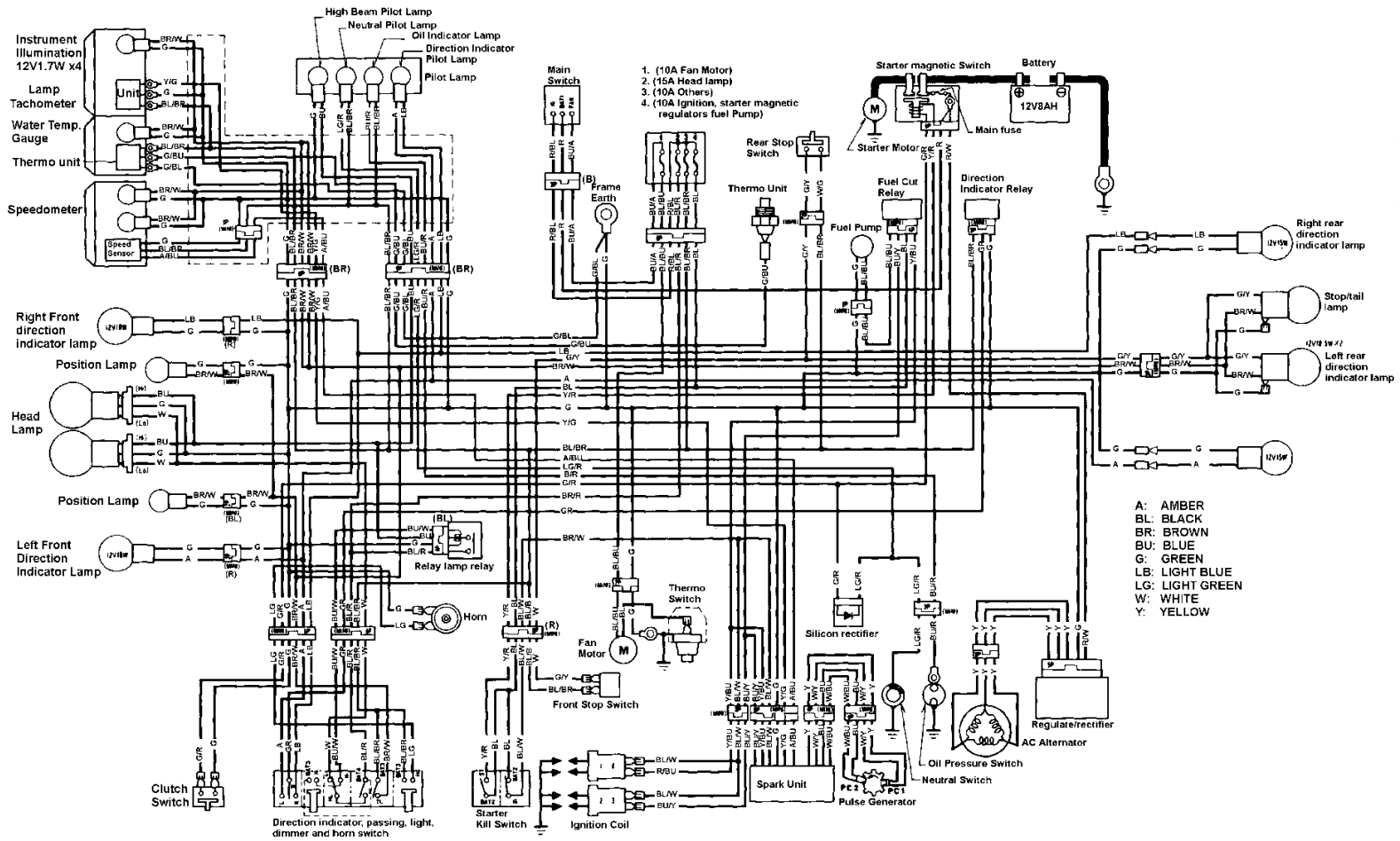

- A: AMBER
- BL: BLACK
- BR: BROWN
- BU: BLUE
- G: GREEN
- LB: LIGHT BLUE
- LG: LIGHT GREEN
- W: WHITE
- Y: YELLOW

### SWITCH CONNECTION

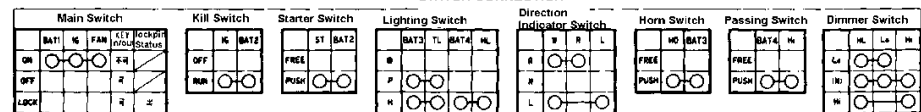

0030Z-KY1-7000

## Table of Contents

Specification .....	24 – 2
Description of the mechanism .....	24 – 3
Torque setting .....	24 – 5
Exclusive / Common tools.....	24 – 5
Wiring.....	24 – 6
Wiring diagram .....	24 – 10
Maintenance data .....	24 – 11
Troubleshooting.....	24 – 14
Maintenance .....	24 – 16
Fuel System.....	24 – 20
Cooling System .....	24 – 36
Engine mount / dismount .....	24 – 41
Cylinder head and valve .....	24 – 43
Cylinder, Piston and Crankshaft .....	24 – 44
Gear shift linkage .....	24 – 45
Front wheel, Suspension and Steering.....	24 – 46
Rear wheel and Suspension .....	24 – 48
Brake System .....	24 – 56
Fairing and Exhaust Pipe.....	24 – 58
Battery and Charging System .....	24 – 61
Ignition System.....	24 – 62
Lamps, Instruments and Switches.....	24 – 66

# CBR250RR (L)

## Specifications

Thick lined cells are different from  
CBR250FOUR / CBR250R

Type		MC22			
Length		1.975m			
Width		0.675m			
Height		1.080m			
Wheelbase		1.345m			
Powerplant		MC14E			
Displacement		0.249l			
Type of fuel		Petrol			
Vehicle weight	Front	80kg			
	Rear	77kg			
	Total	157kg			
Maximum capacity		2			
Gross weight	Front	101kg			
	Rear	166kg			
	Total	267kg			
Tyres	Front	110/70 – R17 54H			
	Rear	140/60 – R17 63H			
Minimum clearance		0.130m			
performance	Brake stop Distance (initial km/h)	14.0m (50km/h)			
	Minimum Turning radius	2.9m			
Powerplant	Starting system		Electric start		
	Type		Petrol, 4 – cycle		
			In-line 4 cylinders		
	Combustion chamber		Pent roof type		
	Valves		DOHC gear driven 2 intake, 2 exhaust		
	Bore x stroke		48.5 x 33.8mm		
	Compression ratio		11.5		
	Compression		13.0kg/cm <sup>2</sup> -400rpm		
	Max horsepower		45PS / 15,000rpm		
	Max torque		2.5kg-m / 12,000rpm		
	Valve timing	I N	Open	19° BTDC (1mm lifted)	
			Close	33° ABDC (1mm lifted)	
		E X	Open	36° BBDC (1mm lifted)	
			Close	11° ATDC (1mm lifted)	
	Valve clearance	IN	0.16mm (cooled)		
		EX	0.23mm (cooled)		
	Unloaded max rpm		1,500rpm		
	Lubrication	Type		Compress/splash	
		Oil pump		Trochoid rotor type	
		Oil filter		Total flow, screen / paper dual type	
Oil capacity		2.7l			
Cooling system		Water cooled, electric fan			
Fuel system	Air cleaner		Filter paper		
	Carb-uretor	Fuel capacity		13l	
		Type		VG20	
		Gas valve dia		30mm	
		Venturi diameter		29mm	
	Electrical system	Type			
		Ignition Timing		23° BTDC/1500 rpm	
		Spark plug	NGK	CR9EH-9, CR10EH-9	
			ND	U27FER9, U31FER9	
		Plug gap		0.8-0.9mm	
Battery capacity		12V6AH			
Drive Train	Clutch	Type		Wet multi plate coil, spring type	
		Operation		Mechanical	
	Engine to transmission reduction ratio		2.966		
	Gear ratio	Type		Constant Mesh	
		Reduction ratio	1 <sup>st</sup>	2.733	
			2 <sup>nd</sup>	2.000	
			3 <sup>rd</sup>	1.590	
			4 <sup>th</sup>	1.333	
			5 <sup>th</sup>	1.153	
	6 <sup>th</sup>		1.035		
Reduction	Primary	Gear type		Chain	
		Reduction ratio		3.058	
Wheels	Front	Caster		24°00'	
		Trail		89mm	
	Tyre Pressure	Front	2.25kg/cm <sup>2</sup>		
		Rear	2.50kg/cm <sup>2</sup>		
Steering angle		Left	31°		
		Right	31°		
Suspension system		Front	Telescopic		
		Rear	Swing Arm		
Brake System		Front	Hydraulic disk		
		Rear	Hydraulic disk		
Frame type		Backbone			
Frame Serial No.		MC22 – 1000001 ~			
Engine Serial No.		MC14E-1140001 ~			

# CBR250RR (L)

---

## Description of the mechanism

### VP carburetor

The CBR250RR is equipped with a VP type carburettor, which has a flat type vacuum piston. The bottom area of the piston was reduced from the area of the conventional circular cross-section piston. This reduces the downward force on the piston bottom (which resists the piston to lift), resulting in improved throttle control response.

Moreover, the dead volume in the carburettor main bore (which is resisting the incoming airflow) is reduced and therefore the intake efficiency is improved.

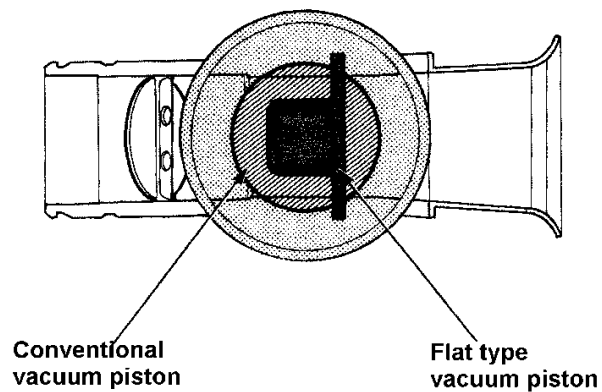
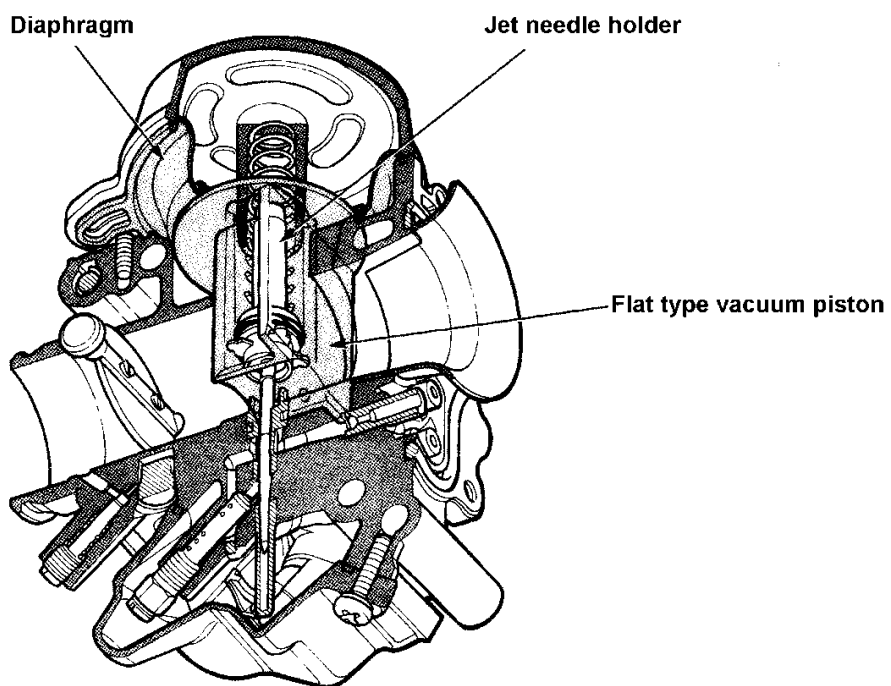



## CBR250RR (L)

---

Two connecting bolts and connecting collars are used to link the carburetors. By linking all #1 to #4 carburettor bodies with the connecting bolt, all carburetors are precisely synchronised.

Installation of the vacuum piston guide to the vacuum chamber cover enables to reduce the size of the piston guide on the carburettor body. Also with the application of the connecting bolts, the number of parts was reduced and the carburettor itself is more simple and compact.

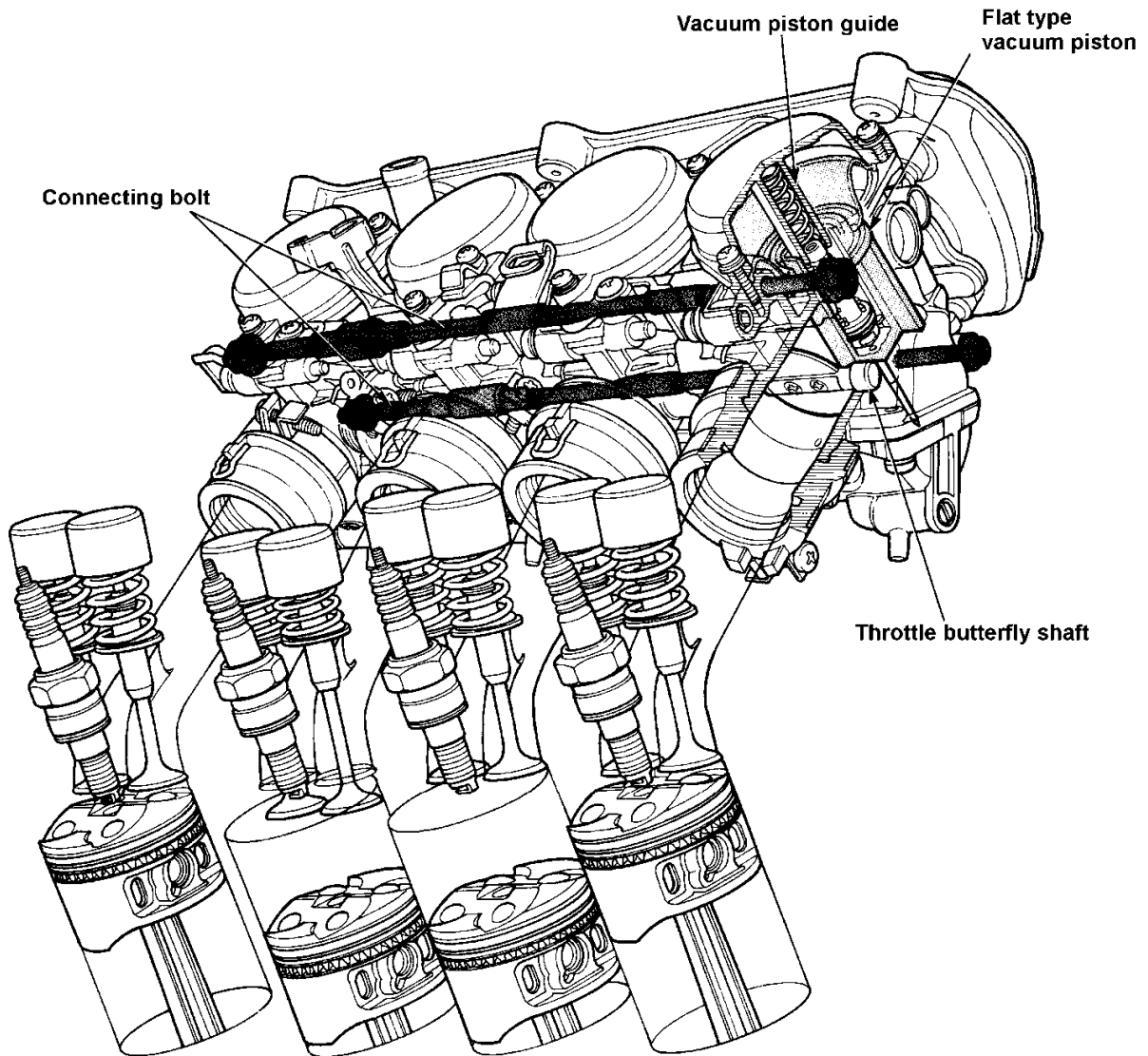

# CBR250RR (L)

## Torque Settings

### Engine

Item	Qty	Screw Dia (mm)	Torque Setting (kg-m)	Notes
Connecting rod bearing cap nut	8	8	1.6 - 2.0	Apply oil to the thread and the seat (Molybdenum oil not permitted).
Lower case sealing bolt	1	18	4.0 - 5.0	Apply screw locker (right side only)

Item	Qty.	Screw Dia (mm)	Torque Setting (kg-m)	Notes
Rear upper engine mount bracket bolt	4	8	3.0 – 4.0	
Rear lower engine mount bracket bolt	2	10	4.5 – 5.5	
Sub frame upper bolt / lower bolt	4	10	4.5 – 5.5	
Side stand bracket bolt	2	10	4.5 – 5.5	
Bottom bridge bolt	2	10	3.0 – 4.0	
Brake hose mount bolt	5	10	3.0 – 4.0	
Rear cushion lower bolt	1	10	4.5 – 5.5	Alloc bolt
Cushion arm bolt	1	10	4.5 – 5.5	Alloc bolt
Rear cushion protection plate bolt	3	5	0.5 – 0.7	Apply screw locker
Change arm bolt	1	6	1.4 – 1.8	
Right / left step pivot bolt	2	8	3.5 – 4.5	Alloc bolt
Silencer bolt	3	6	1.6 – 2.0	Torx bolt
Ignition switch mount bolt	2	8	2.4 – 3.0	Alloc bolt
Ignition coil mount screw	4	6	0.7 – 1.1	Alloc bolt

Notes: replace with new ones when the alloc bolts are removed.

### Special tools

Tool name	Tool No.	Qty.	Application
Drive chain staking tool	07HMH-MR10101	1	Drive chain replacement
Bearing remover attachment	07LMC-KV30200	1	Rear fork left pivot bearing removal
Ball race remover - bearing remover A	07946-KM90001 07946-KM90401	1 1	Ball race replacement (only the bearing remover A is different from 07946-KM90000).
Valve guide remover (3.5mm)	07HMH-KT70101	1	Valve guide clearing / finishing
Pilot screw wrench	07908-4220201	1	Pilot screw adjustment

### Common Tools

Tool name	Tool No.	Qty.	Application
Pilot (20mm)	07746-0040500	1	Front wheel bearing, rear driven flange bearing installation
Torx bit: T-40	07703-0010100	1	Ignition switch removal/installation
Torx bit: T-30	07703-0010200	1	Muffler removal/installation
Torx bit: T-10H	-	1	Ignition switch disassembly/assembly (available in market)

### Measuring Tool

Tool name	Tool No.	Qty.	Application
Peak voltage adapter	07HGJ-0020100	1	Ignition inspection

# CBR250RR (L)

## Routing

## Diagram

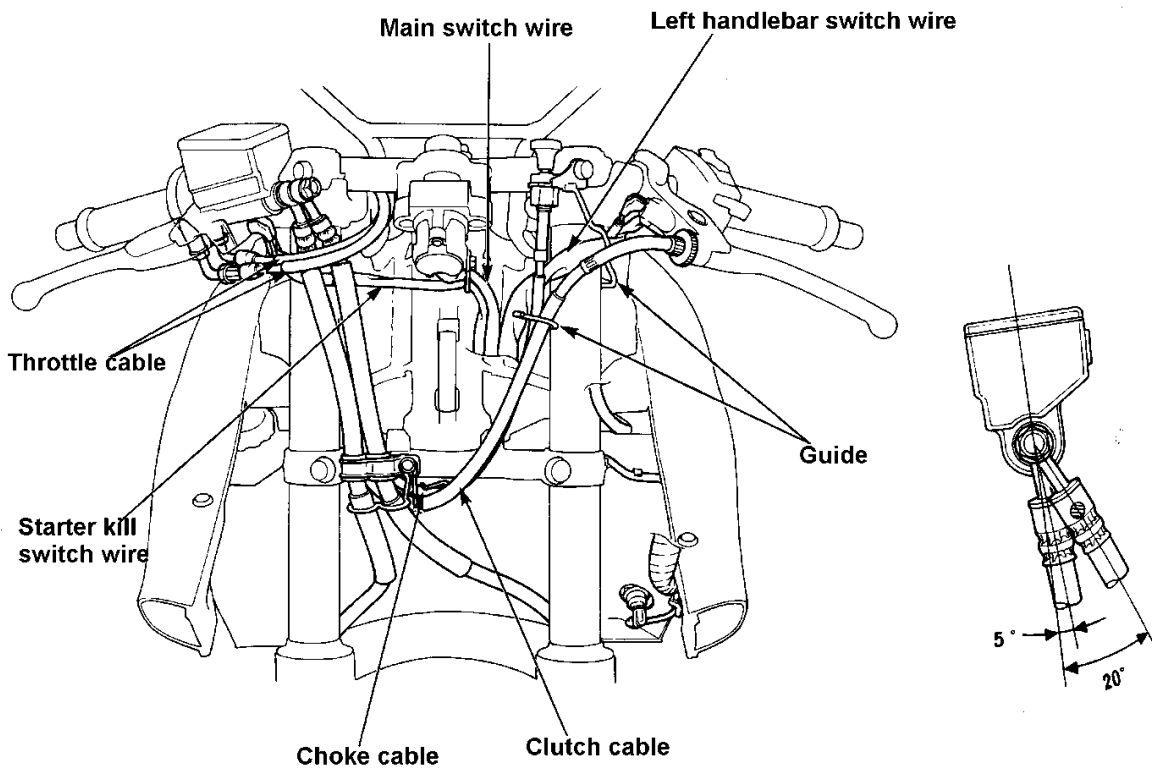
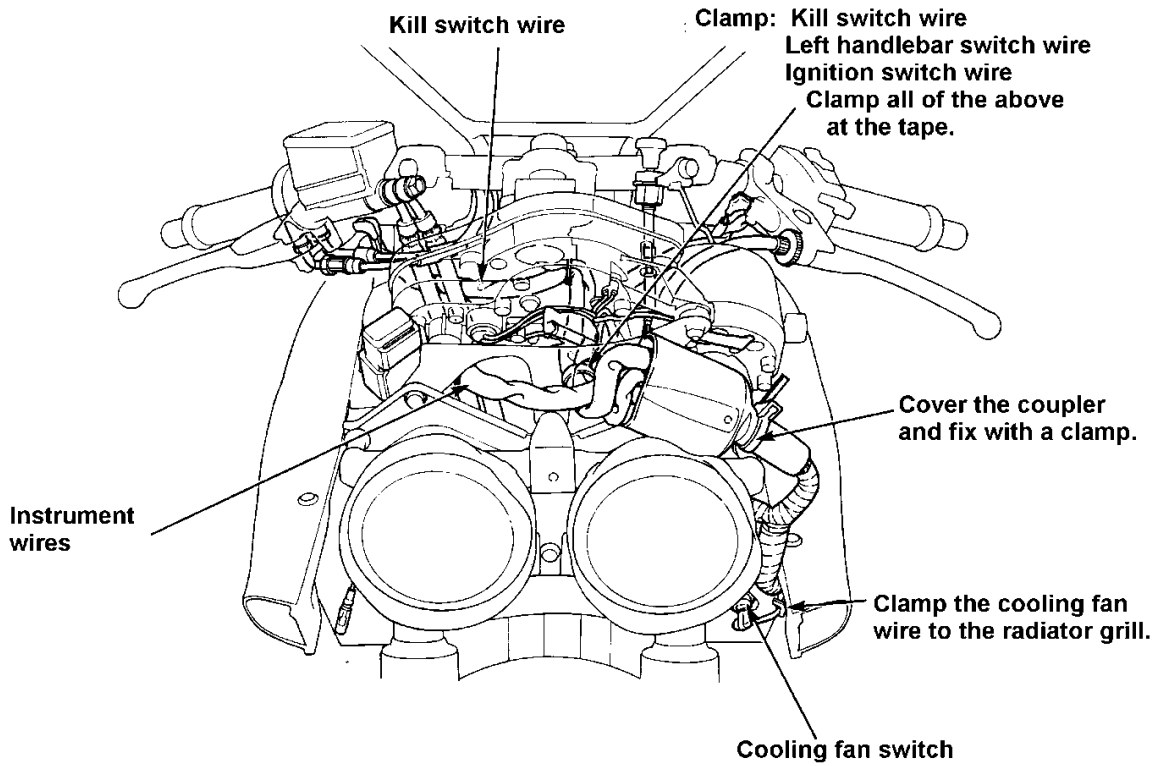

# CBR250RR (L)

---

Clamp the following at the tape.  
(Kill switch wire  
(Left handlebar switch wire  
(Ignition switch wire

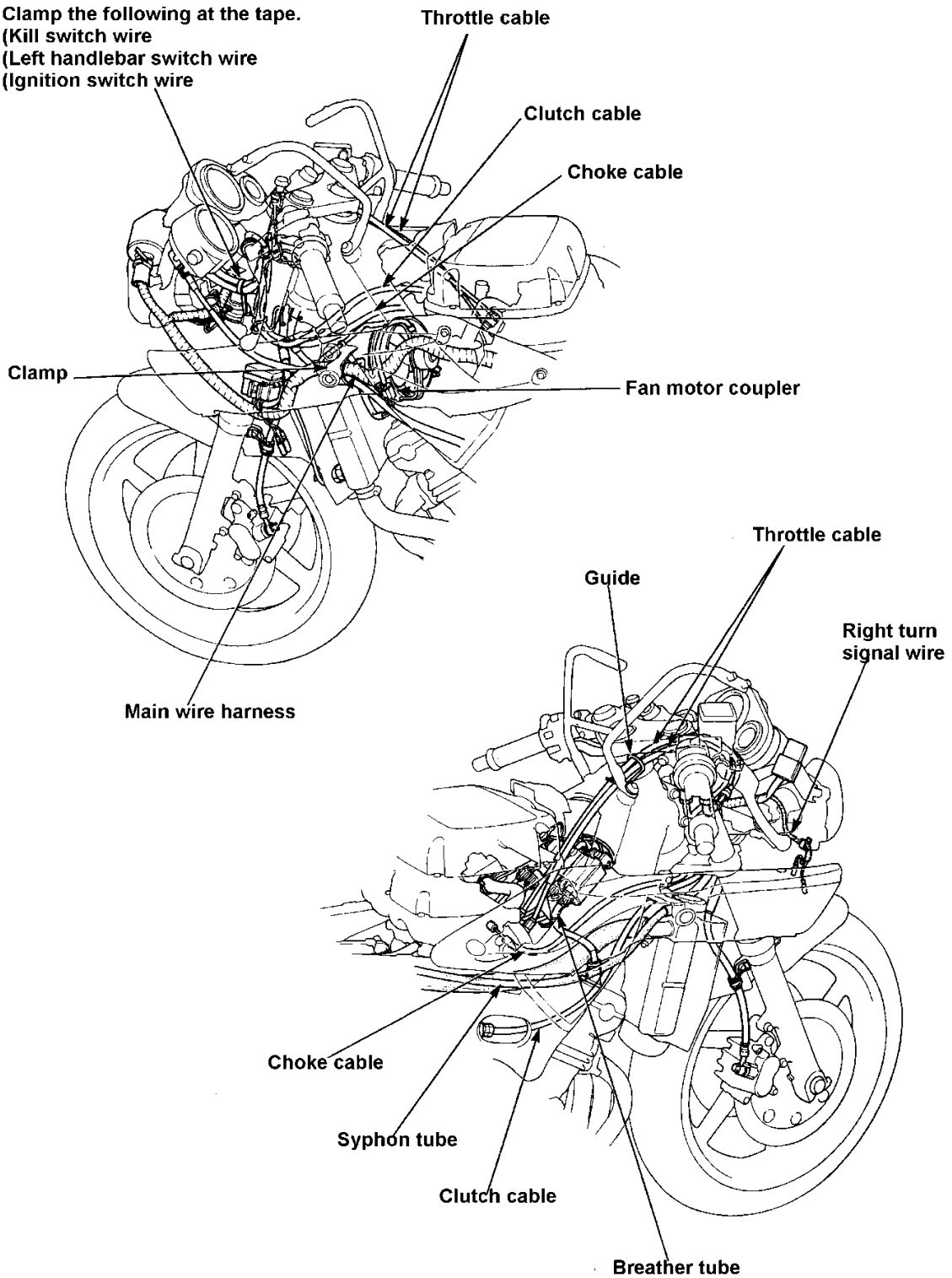

# CBR250RR (L)

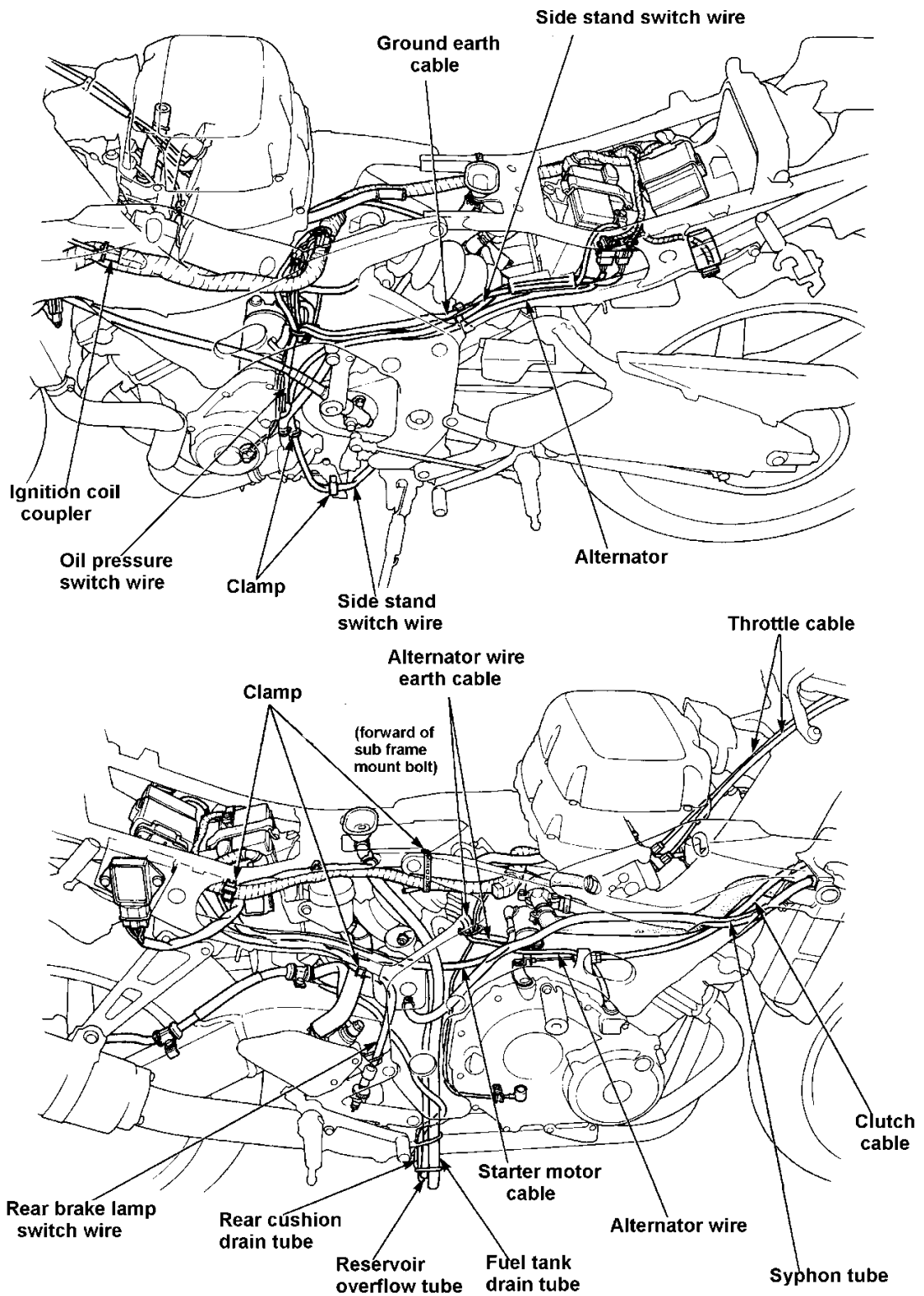

# CBR250RR (L)

---

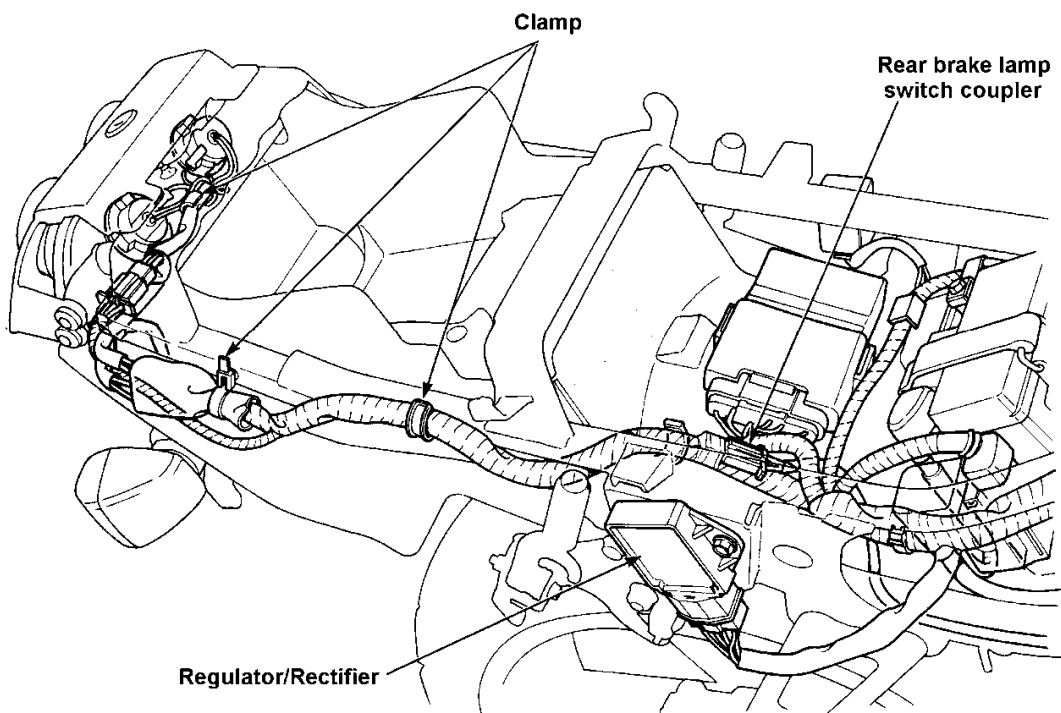
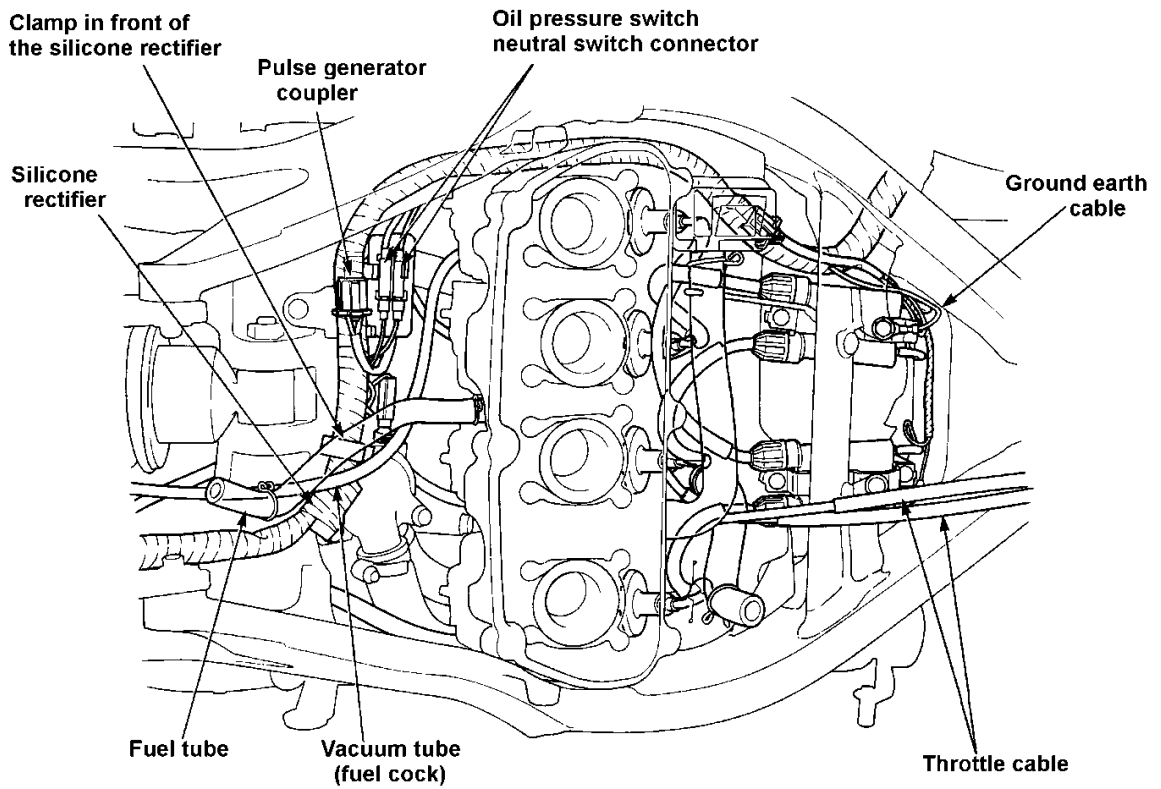

24-10

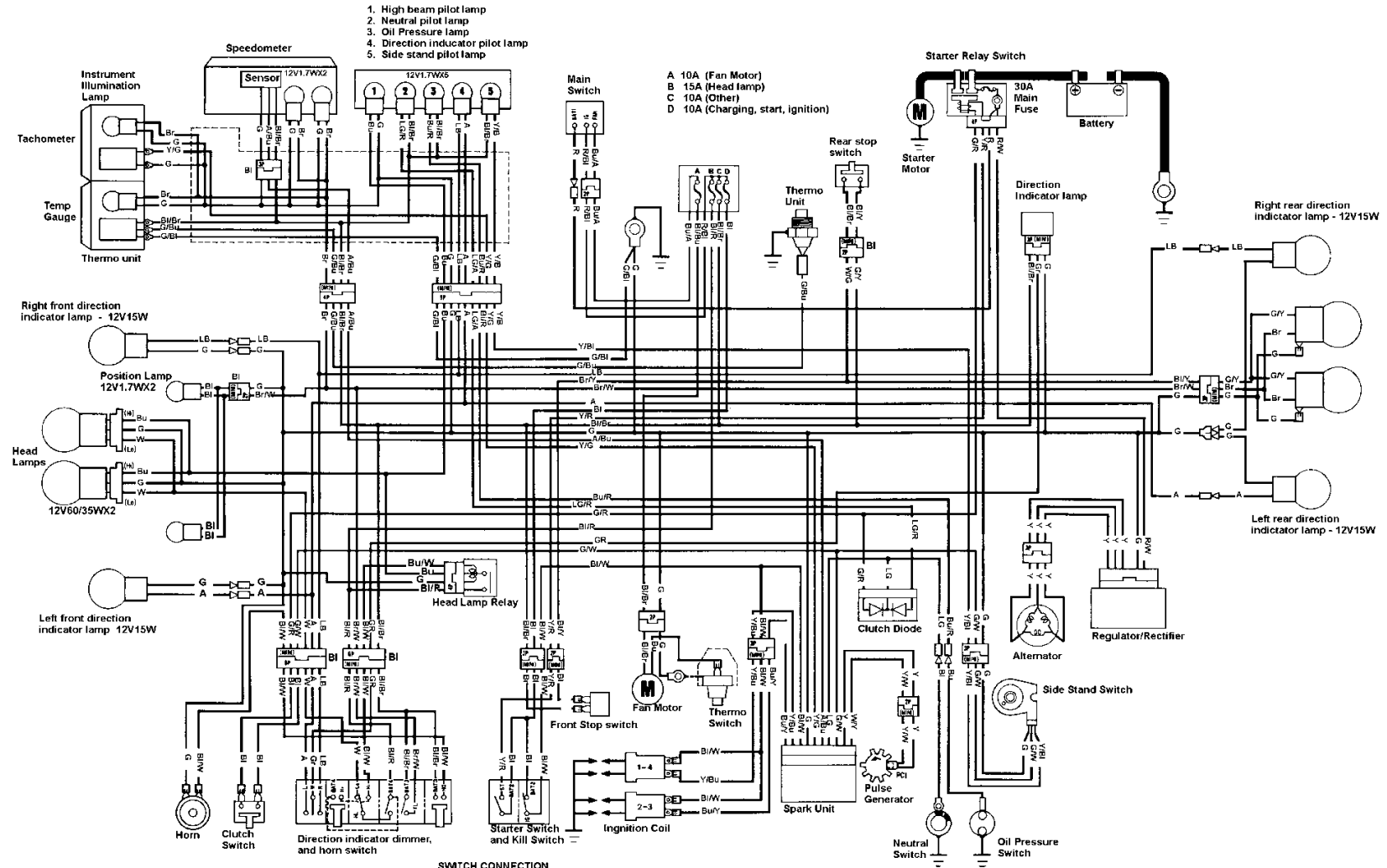

1. High beam pilot lamp
2. Neutral pilot lamp
3. Oil Pressure lamp
4. Direction indicator pilot lamp
5. Side stand pilot lamp

- A 10A (Fan Motor)  
 B 15A (Head lamp)  
 C 10A (Other)  
 D 10A (Charging, start, ignition)

SWITCH CONNECTION

Main Switch	Kill Switch	Starter Switch	Lighting Switch	Direction Indicator	Horn Switch	Passing Switch	Dimmer Switch																																																																																																																																																																																																																								
<table border="1"> <tr> <td>IN</td> <td>BAT1</td> <td>IG</td> <td>FAN</td> <td>Key</td> <td>lock</td> <td>lin</td> <td></td> </tr> <tr> <td>ON</td> <td>○</td> <td>○</td> <td>○</td> <td>No</td> <td>○</td> <td>○</td> <td>○</td> </tr> <tr> <td>OFF</td> <td>○</td> <td>○</td> <td>○</td> <td>Yes</td> <td>○</td> <td>○</td> <td>○</td> </tr> <tr> <td>LOCK</td> <td>○</td> <td>○</td> <td>○</td> <td>Yes</td> <td>Out</td> <td>○</td> <td>○</td> </tr> </table>	IN	BAT1	IG	FAN	Key	lock	lin		ON	○	○	○	No	○	○	○	OFF	○	○	○	Yes	○	○	○	LOCK	○	○	○	Yes	Out	○	○	<table border="1"> <tr> <td>OFF</td> <td>BAT2</td> <td></td> <td></td> <td></td> <td></td> <td></td> <td></td> </tr> <tr> <td>ON</td> <td>○</td> <td></td> <td></td> <td></td> <td></td> <td></td> <td></td> </tr> <tr> <td>LOCK</td> <td>○</td> <td></td> <td></td> <td></td> <td></td> <td></td> <td></td> </tr> </table>	OFF	BAT2							ON	○							LOCK	○							<table border="1"> <tr> <td>ST</td> <td>BAT2</td> <td></td> <td></td> <td></td> <td></td> <td></td> <td></td> </tr> <tr> <td>PUSH</td> <td>○</td> <td></td> <td></td> <td></td> <td></td> <td></td> <td></td> </tr> </table>	ST	BAT2							PUSH	○							<table border="1"> <tr> <td>BAT3</td> <td>TL</td> <td>BAT4</td> <td>HL</td> <td></td> <td></td> <td></td> <td></td> </tr> <tr> <td>○</td> <td>○</td> <td>○</td> <td>○</td> <td></td> <td></td> <td></td> <td></td> </tr> <tr> <td>P</td> <td>○</td> <td>○</td> <td>○</td> <td></td> <td></td> <td></td> <td></td> </tr> <tr> <td>H</td> <td>○</td> <td>○</td> <td>○</td> <td></td> <td></td> <td></td> <td></td> </tr> </table>	BAT3	TL	BAT4	HL					○	○	○	○					P	○	○	○					H	○	○	○					<table border="1"> <tr> <td>R</td> <td>W</td> <td>R</td> <td>L</td> <td></td> <td></td> <td></td> <td></td> </tr> <tr> <td>○</td> <td>○</td> <td>○</td> <td>○</td> <td></td> <td></td> <td></td> <td></td> </tr> <tr> <td>N</td> <td>○</td> <td>○</td> <td>○</td> <td></td> <td></td> <td></td> <td></td> </tr> <tr> <td>L</td> <td>○</td> <td>○</td> <td>○</td> <td></td> <td></td> <td></td> <td></td> </tr> </table>	R	W	R	L					○	○	○	○					N	○	○	○					L	○	○	○					<table border="1"> <tr> <td>FREE</td> <td>HO</td> <td>BAT3</td> <td></td> <td></td> <td></td> <td></td> <td></td> </tr> <tr> <td>○</td> <td>○</td> <td>○</td> <td></td> <td></td> <td></td> <td></td> <td></td> </tr> <tr> <td>PUSH</td> <td>○</td> <td>○</td> <td></td> <td></td> <td></td> <td></td> <td></td> </tr> </table>	FREE	HO	BAT3						○	○	○						PUSH	○	○						<table border="1"> <tr> <td>FREE</td> <td>BAT4</td> <td>N</td> <td></td> <td></td> <td></td> <td></td> <td></td> </tr> <tr> <td>○</td> <td>○</td> <td>○</td> <td></td> <td></td> <td></td> <td></td> <td></td> </tr> <tr> <td>PUSH</td> <td>○</td> <td>○</td> <td></td> <td></td> <td></td> <td></td> <td></td> </tr> </table>	FREE	BAT4	N						○	○	○						PUSH	○	○						<table border="1"> <tr> <td>HL</td> <td>Lp</td> <td>Lp</td> <td>H</td> <td></td> <td></td> <td></td> <td></td> </tr> <tr> <td>○</td> <td>○</td> <td>○</td> <td>○</td> <td></td> <td></td> <td></td> <td></td> </tr> <tr> <td>N</td> <td>○</td> <td>○</td> <td>○</td> <td></td> <td></td> <td></td> <td></td> </tr> <tr> <td>H</td> <td>○</td> <td>○</td> <td>○</td> <td></td> <td></td> <td></td> <td></td> </tr> </table>	HL	Lp	Lp	H					○	○	○	○					N	○	○	○					H	○	○	○				
IN	BAT1	IG	FAN	Key	lock	lin																																																																																																																																																																																																																									
ON	○	○	○	No	○	○	○																																																																																																																																																																																																																								
OFF	○	○	○	Yes	○	○	○																																																																																																																																																																																																																								
LOCK	○	○	○	Yes	Out	○	○																																																																																																																																																																																																																								
OFF	BAT2																																																																																																																																																																																																																														
ON	○																																																																																																																																																																																																																														
LOCK	○																																																																																																																																																																																																																														
ST	BAT2																																																																																																																																																																																																																														
PUSH	○																																																																																																																																																																																																																														
BAT3	TL	BAT4	HL																																																																																																																																																																																																																												
○	○	○	○																																																																																																																																																																																																																												
P	○	○	○																																																																																																																																																																																																																												
H	○	○	○																																																																																																																																																																																																																												
R	W	R	L																																																																																																																																																																																																																												
○	○	○	○																																																																																																																																																																																																																												
N	○	○	○																																																																																																																																																																																																																												
L	○	○	○																																																																																																																																																																																																																												
FREE	HO	BAT3																																																																																																																																																																																																																													
○	○	○																																																																																																																																																																																																																													
PUSH	○	○																																																																																																																																																																																																																													
FREE	BAT4	N																																																																																																																																																																																																																													
○	○	○																																																																																																																																																																																																																													
PUSH	○	○																																																																																																																																																																																																																													
HL	Lp	Lp	H																																																																																																																																																																																																																												
○	○	○	○																																																																																																																																																																																																																												
N	○	○	○																																																																																																																																																																																																																												
H	○	○	○																																																																																																																																																																																																																												

# CBR250RR (L)

## Service Information

### Specification

#### Fuel System

Item		Standard	
Venturi diameter		9.1mm equivalent	
Setting mark		VP20A	
Float level		13.7mm	
Main jet		No:1.4 : #105	No. 2.3: #102
Jet needle mark		J93B	
Pilot screw rewinding		1 – ¾ revs	
Slow jet		# 35	
Fuel tank capacity	Total	13 l	
	Reserve	1.6 l	

#### Cooling System

Item	Standard	Service limit
Radiator cap valve opening pressure	1.10 – 1.40kg/cm <sup>2</sup>	1.10kg/cm <sup>2</sup> or less / 1.40kg/cm <sup>2</sup> or more
Coolant capacity	Total : 1570cc (approx)	Radiator side: 1350cc approx Reservoir side: 220cc approx

#### Engine mounting / dismounting

Engine weight (service)	48.5kg (approx)
-------------------------	-----------------

#### Cylinder head / valve

Unit: mm

Item			Standard	Service limit
Cam shaft	Cam lift	IN	28.94 – 29.18	28.91
		EX	28.51 – 28.75	28.48
Valve spring	Relaxed length		37.65	36.65
Valve and valve guide	Valve stem external diameter	IN	3.481-3.495	3.476
		EX	3.465-3.480	3.460
	Stem guide clearance	IN	0.005-0.032	0.10
		EX	0.020-0.047	0.13
Valve lifter	External diameter		19.978-19.993	19.970
Cylinder head	Valve lifter contact area bore		20.010-20.026	20.035



# CBR250RR (L)

## Cylinder, Piston and Crankshaft

Unit: mm

Item			Standard	Service limit
Crankshaft and connecting rod	Connection rod big end	Side clearance	0.10 – 0.25	0.30
	Main journal	Side clearance	0.022 – 0.040	0.06
Piston Ring	Ring end gap	Second	0.21 – 0.36	0.45

			Connecting rod bore code		
			1	2	3
			30.000 – 30.006mm	30.006 – 30.012mm	30.012 – 30.018mm
Crankpin ext. dia code	A	27.494-27.500mm	E (Yellow)	D (Green)	C (Brown)
	B	27.488-27.494mm	D (Green)	C (Brown)	B (Black)
	C	27.482-27.488mm	C (Brown)	B (Black)	A (Blue)

Bearing Metal Thickness:

A (Blue):	1.252-1.255mm
B (Black):	1.249-1.252mm
C (Brown):	1.246-1.249mm
D (Green):	1.243-1.246mm
E (Yellow):	1.240-1.243mm

## Front Wheel and Suspension

Item		Standard	Service limit
Front fork oil quantity		383 ± 2.5cc	-
Oil level		83mm	-
Front fork oil brand		Honda Ultra Cushion Oil # 10	-
Front cushion spring	Relaxed length	252.1mm	247mm
	Installing direction	Tapered end to the bottom	

## Rear Wheel and Suspension

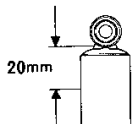
Item		Standard	Service limit
Rear cushion damper compression (10mm compressed)		15.4kg	12.3kg
Rear cushion spring installation length		135mm	-
Rear cushion spring relaxed length		143.8mm	140.9mm
Damper unit gas releasing hole position		20mm from the damper case upper end 	

## Brake System (Disc Brake)

Item		Standard	Service limit
Brake disc runout	Front	-	0.4
	Rear	-	0.3
Front master cylinder bore		12.700 – 12.743	12.755
Rear master cylinder bore		14.000 – 14.043	14.06
Front master piston external diameter		12.657 – 12.684	12.65
Rear master piston external diameter		13.957 – 13.984	13.95
Front caliper cylinder bore		25.400 – 25.450	25.46
Rear caliper cylinder bore		38.180 – 38.230	38.24
Front caliper piston external diameter		25.335 – 25.386	25.33
Rear caliper piston external diameter		38.098 – 38.148	38.09

# CBR250RR (L)

---

## Ignition System

Item		Standard
Ignition coil	Primary coil resistance (20°C)	2.0 – 3.5Ω
	Primary coil peak voltage	128V or above
	Secondary coil resistance (20°C)	With cap 23 – 37kΩ Without cap 13 – 17kΩ
Pulse generator	Coil resistance (20°C)	340 - 420Ω
	Peak voltage White / Yellow and Yellow	0.91V

## Charging System

Item	Standard
Alternator resistance (20°C)	0.1 – 0.5Ω
Alternator performance	270W / 5,000rpm
Charging commencement rpm (headlamp ON, low beam)	2,000rpm

## Lamps, Instruments and Switches

Item	Standard
Pilot lamp and instrument illumination lamp	12V 1.7 W x 9
Front turn signal bulb	12V 15W x 2
Rear turn signal bulb	12V 15W x 2

# CBR250RR (L)

## Troubleshooting

### Faulty charging (flat battery)

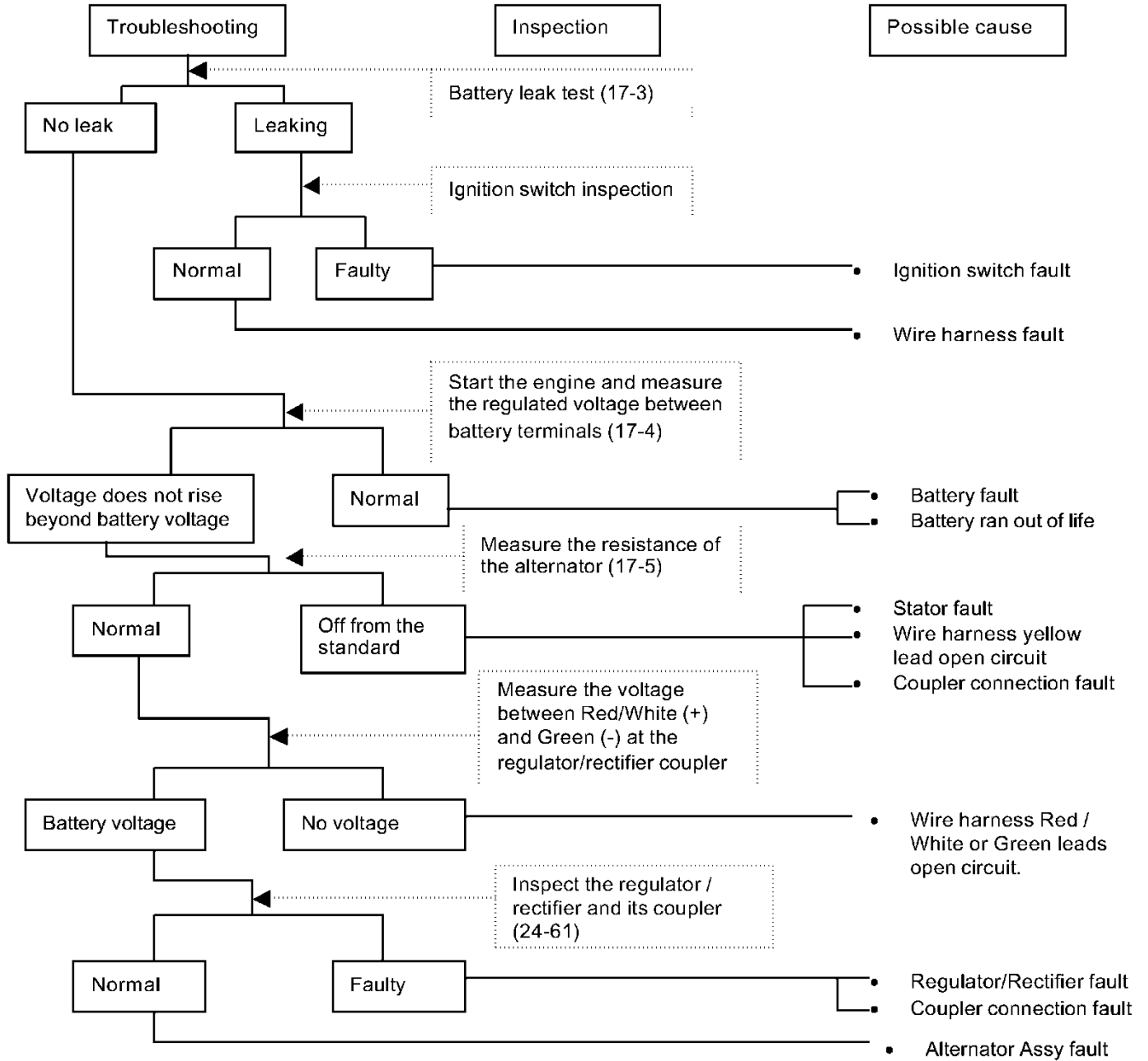

### Faulty charging (overcharging)

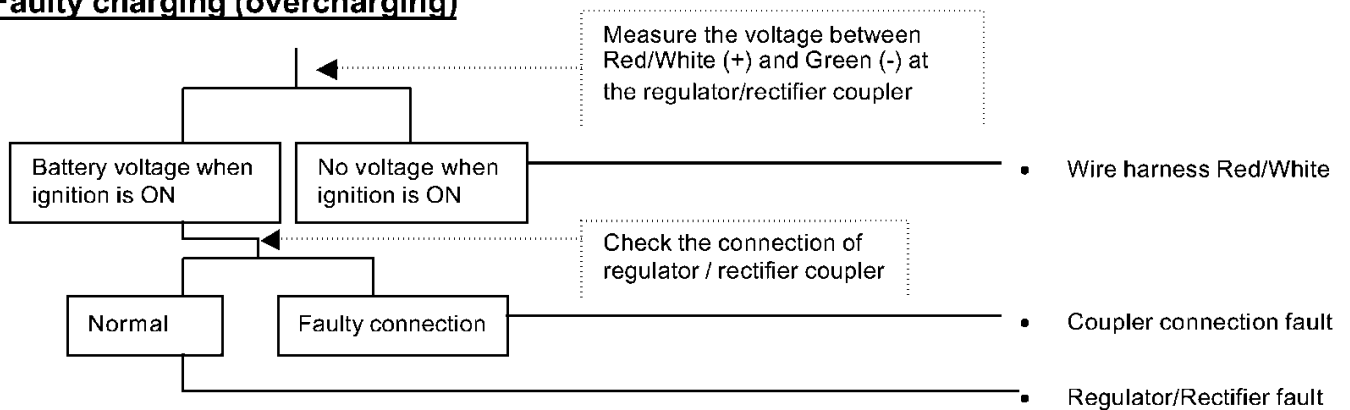

# CBR250RR (L)

## No Spark on the Spark Plugs

- Before starting the troubleshooting, test with a good spark plug to eliminate the possibility of the spark plug fault. Also, make sure the connection of plug caps and high tension leads are fine and there is no secondary current leak from the ignition coil due to moisture.
- If a particular ignition coil does not generate spark, swap the ignition coil and test again. If the symptom is still the same, measure the primary voltage of the ignition coil. If spark is generated normally by swapping the ignition coils, the original coil is faulty.
- The “initial voltage” of the ignition coil primary voltage is the one measured when the ignition switch is turned ON with the kill switch ON (while the engine is not cranked).

Symptom		Suspected cause (check from ①)
Ignition coil primary voltage	No initial voltage when the ignition switch is ON and the kill switch is RUN, but other electrical accessories are operating normally.	① Faulty kill switch. ② Open circuit between the switch and the ignition coil. ③ Faulty connection/open circuit on the ignition primary voltage leads/coupler (measure the resistance of the primary voltage lines between spark unit terminals). ④ If the initial voltage is normal when the spark unit is removed, the spark unit is faulty.
	Initial voltage is normal. However, the voltage drops 2 ~ 4 volts when cranking.	① Peak voltage adapter misconnected. ② Battery almost flat (large voltage drop when cranking). ③ No voltage on Black/White lead on the spark unit, or the spark unit coupler connection fault. ④ Spark unit green lead open circuit or connection fault. ⑤ Ignition coil – spark unit (Yellow/Blue or Blue/Yellow leads) open circuit or coupler connection fault. ⑥ Ignition coil primary voltage lead short circuit. ⑦ Side stand switch or relevant (Green/White, Green lead, and couplers) parts fault. ⑧ Pulse generator fault (measure peak voltage). ⑨ Spark unit fault (if all of ① - ⑧ are normal).
	Initial voltage is normal, but very little or no peak voltage while cranking.	① Peak voltage adapter misconnected. ② Peak voltage adapter fault. ③ Spark unit fault (if all of ① - ② are normal).
	Initial voltage is normal but the peak voltage is low.	① Internal resistance of the multi meter is low. ② Too low cranking speed <ul style="list-style-type: none"> <li>• Battery almost flat</li> </ul> ③ Effect of the sampling time of the multi meter (measure few times). ④ Spark unit fault (if all of ① - ③ are normal and no spark on plugs).
	Both initial and peak voltage are normal but no spark.	① Spark unit fault or ignition coil secondary current leak. ② Faulty ignition coil.
Pulse Generator	Low peak voltage.	① Internal resistance (impedance) of the multi meter is low. ② Too low cranking speed <ul style="list-style-type: none"> <li>• Battery almost flat</li> </ul> ③ Effect of the sampling time of the multi meter (measure few times). ④ Pulse generator fault (if all of ① - ③ are normal).
	Little or no peak voltage	① Faulty peak voltage adapter. ② Faulty pulse generator.

# CBR250RR (L)

## Inspection / Adjustment - Service Schedule

### Notes:

- Service items include high speed operation service items.
- (●) are mandatory service items, while (○) are the manufacturers recommendation.
- (✧) are regular replacement of security parts.  
However, regular intervals are designed to the vehicles operated in standard condition.  
The interval may be varied considering the vehicles specific operating environment.
- High speed operation is such an operation at or above 80km/h.

Service Item		Schedule				Notes				
		Regular	Initial 1 month or 1000km	Private						
				6 month	12 month					
Steering System	Steering handle	Free play / loose fit				●				
		Controllability					●			
	Steering wheel	Steering angle of the wheel					●			
	Steering fork	Damage			●	●				
		Fork, spindle attachment			●	●		Steering stem		
Fork, spindle bearing						●	Steering stem			
Braking System	Brake pedal	Clearance between the pedal and the floor when the pedal is fully depressed.			●	●		Free Play: Front brake (lever) at lever end: 20 – 30mm Rear brake (pedal): 10 – 20mm		
		Free play and effectiveness	●							
		Braking performance		○	●	●				
	Hose & Pipe	Leak, damage and attachment		○	●	●				
		Brake hose replacement						✧ every four years		
	Reservoir	Brake fluid level (quantity)	●		●	●		Reservoir brake fluid level: Front: Above minimum level Rear: Between min-max level		
	Master/wheel cylinder and caliper	Function, wear and damage					●			
		Master / Wheel cylinder cup, dust seal and disc caliper rubber parts replacement.						✧ Bi-annual		
	Disc / Pad	Disc pad clearance					●			
		Pad wear			○	●		Indicator type		
		Disc wear and damage					●	Standard thickness: Front 4.0mm Rear 5.0mm Service limit: Front 3.5mm Rear 4.0mm		
	Fluid	Brake fluid change						✧ Annual		
Driving System	Wheels	Tyre Pressure	●		●	●	(unit: kg/cm <sup>2</sup> )			
							1 person	Normal	Front 2.25	Rear 2.25
								High speed	2.25	2.25
							2 people	Normal	2.25	2.50
Tyre specification		110/70 R17 54H	140/60 R17 63H							

# CBR250RR (L)

Service Item		Schedule				Notes	
		Regular	Initial 1 month or 1000km	Private			
				6 month	12 month		
Driving System	Wheels	Tyre crack and damage	●		●	●	
		Tyre tread and unusual wear	●		●	●	Tread = 0.8mm front, 0.8mm rear
		Debris etc.	●	●		●	
		Wheel nuts / bolts tightness			●	●	Axle bolts / nuts: Front axle holder torque: 1.8 – 2.5kg-m Front axle bolt torque: 5.5 – 6.5kg-m Rear axle nut torque: 8.0 – 10.0kg-m
		Rim, side ring and wheel disc damage		○		●	Wheel rim runout at rim edge: Front wheel rim: Axial 2.0mm Radial 2.0mm Rear wheel rim: Axial 2.0mm Radial 2.0mm
		Front wheel bearing fit				●	
		Rear wheel bearing fit				●	
Shock absorbing system	Chassis spring				●	Cushion spring	
	Suspension arm				●	Joint looseness and arm damage	
	Shock absorber	Oil leak and damage				●	
		Mount fit				●	
Transmission System	Clutch	Lever free play			●	●	Free play at lever end: 10 – 20mm
		Operation		○	●	●	
	Transmission	Oil leak and level			●	●	Dipstick type: Between min – max lines
		Mechanical operation				●	
	Chain / sprocket	Chain slack		○	●	●	Side stand extended at the midpoint between two sprockets: 15 – 25mm maximum
		Sprocket attachment and wear				●	
Electrical system	Ignition system			●	●	Plug gap: 0.8 – 0.9mm	
	Battery				●	Terminal connection	
	Wiring				●	Connection, damage on cables	
Powerplant	Main component	Starting and noise			●	●	
		Low speed and acceleration		○	●	●	Idling rpm: 1,500 ± 100rpm
		Exhaust			●	●	
		Air filter change					Every 20,000km
		Valve clearance		○		●	Intake (cooled): 0.13 – 0.19mm Exhaust (cooled): 0.20 – 0.26mm

# CBR250RR (L)

Service Item		Schedule				Notes		
		Regular	Initial 1 month or 1000km	Private				
				6 month	12 month			
Powerplant	Lubrication	Oil dirt and quantity			●	●	Dipstick type: Between min – max lines	
		Oil leak			●	●		
		Oil level	●					
		Engine oil change		○				Initial 1,000km then every 6,000km
		Oil cleaner change						Initial 13,000km then every 12,000km
	Fuel System	Fuel leak			●	●		
		Carburettor link				●		
		Throttle valve and choke valve				●		
		Fuel filter				●		
		Fuel quantity	●					
	Cooling system	Fuel hose change						✂ every four years
		Coolant level	●		●	●		Reservoir between min – max lines
		Coolant leak	●			●		
Radiator cap function					●		1.10 – 1.40kg/cm <sup>2</sup> valve opening pressure	
Exterior lamps	Operation			●	●			
	Flashing, dirt and damage	●						
Horn and Lock	Operation				●			
Rearview mirror	Vision	●					Rearview mirrors only	
Reflector and registration plate	Dirt and damage	●						
Instruments	Operation				●			
Exhaust pipe and muffler	Attachment and damage				●			
	Muffler function				●			
Frame	Attachment and damage				●			
Defects discovered on previous day	Being serviced and normal	●						
Others	Greasing to the vehicle			●	●			

# CBR250RR (L)

## Transmission System

### < Chain slider wear >

Remove the drive sprocket cover (6-3).  
Inspect the chain slider for wear damage.  
Replace it if it is worn to the wear limit (24-49).

Replace the slider as early as possible as it will prevent the chain contacting the rear fork, which may damage/wear the chain and the fork.

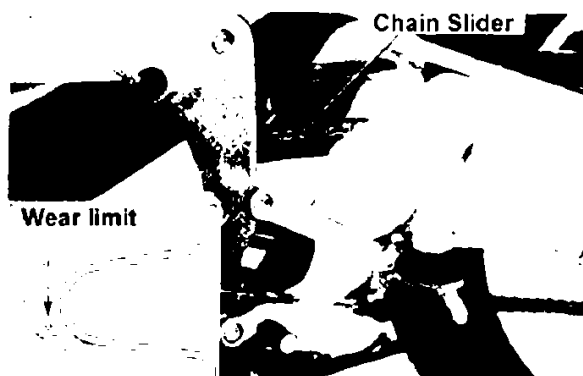

### < Chain replacement >

#### Caution

Do not use any chain or tool other than the designated products.  
Never use a clip type chain.

Relax the chain to find out the staked part.  
Set the tool to cut the stake.

#### Special tools

Drive chain staking tool: 07HMH-MR10101  
or equivalent products available from the market.

- Read the instructions when using the staking tool.
- Do not re-use the master link, O-Rings and the link plate.

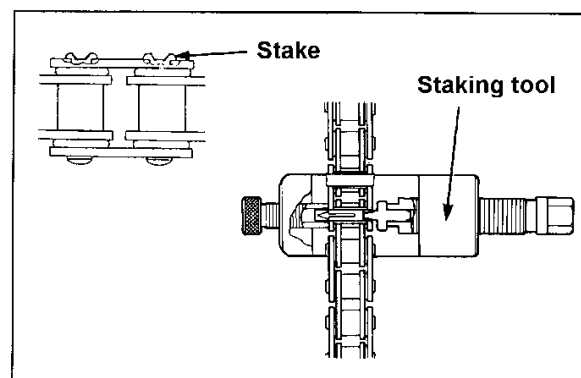

Replace with a new chain.

Designated replacement chain: DID 428VS1  
RK 428SH0Z1

Install O-Rings to the new master link.

Install the master link from the inner side of the chain.

Do not catch the O-Ring.

Install O-Rings and the link plate from the other side of the chain by using a special tool.

Stake the master link joint pins.

- Face the labeled side of the master link plate outwards.
- Do not catch O-Rings.

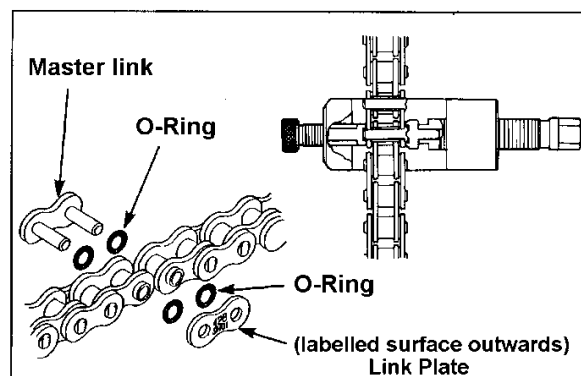

Make sure the staked parts are free from cracks.

If there is any crack, re-stake by using a new masterlink, a new link plate and O-Ring.

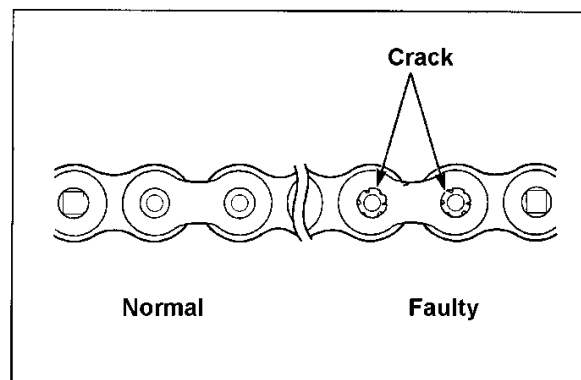

**Caution** Do not use clip-type chain



# CBR250RR (L)

## Fuel System

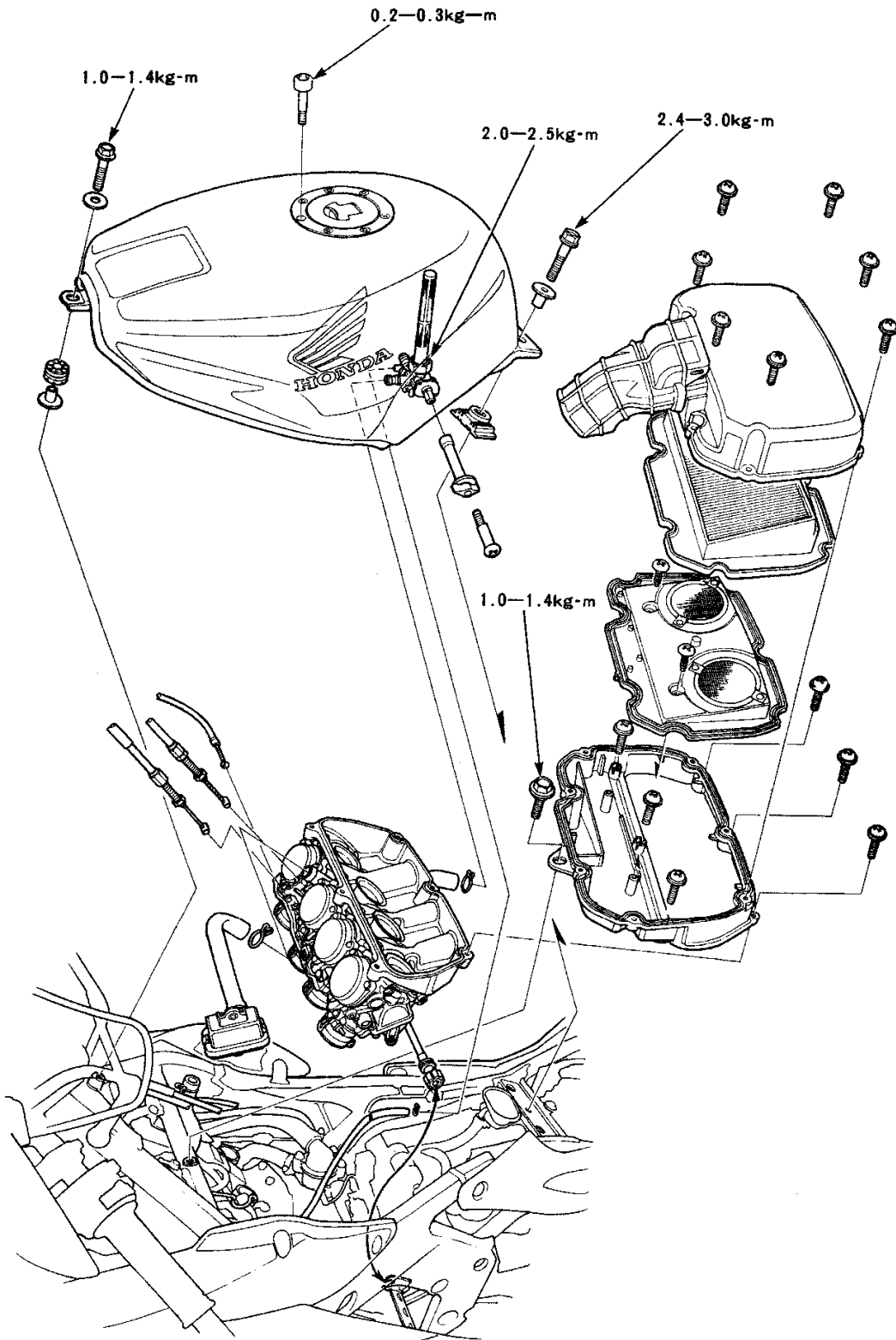

# CBR250RR (L)

## Fuel Tank Removal

### **Caution**

- Highly flammable. Keep away from fire.
- Wipe off spilt fuel straight away.

Remove the seat.  
Turn the fuel cock "OFF".  
Unscrew fuel tank mount bolts.

Lift up the tank.  
Disconnect the vacuum tube and the fuel tube  
from the fuel cock.

Lift up the front part of the tank first, and remove  
the tank to the right, upwards.

Do not bend the fuel cock lever.

## Fuel Tank installation

Follow the removal procedure in reverse order.

- Do not bend or squash the vacuum tube.
- Check for fuel leak after installation.

Torque Setting: Fuel tank mount bolt  
Front: 1.0 ~ 1.4kg-m  
Rear: 2.4 ~ 3.0kg-m

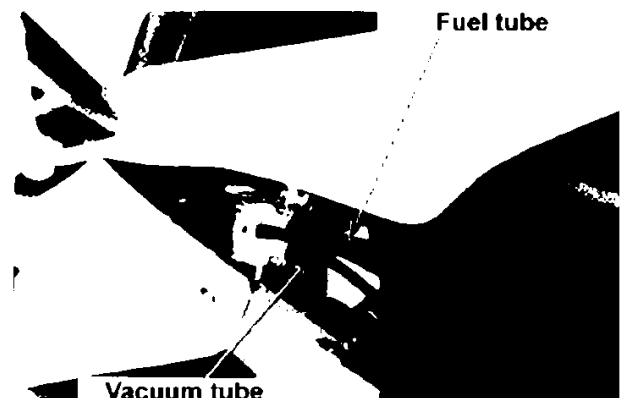
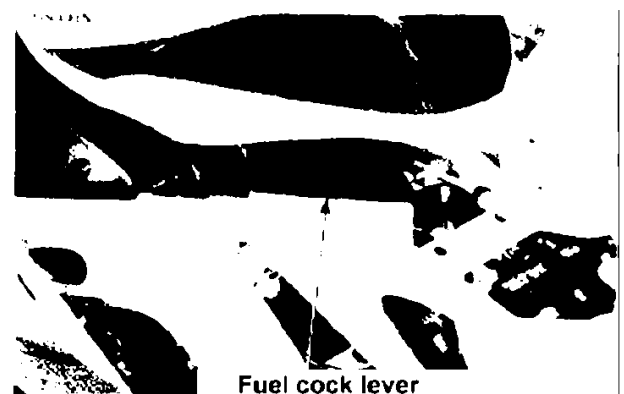
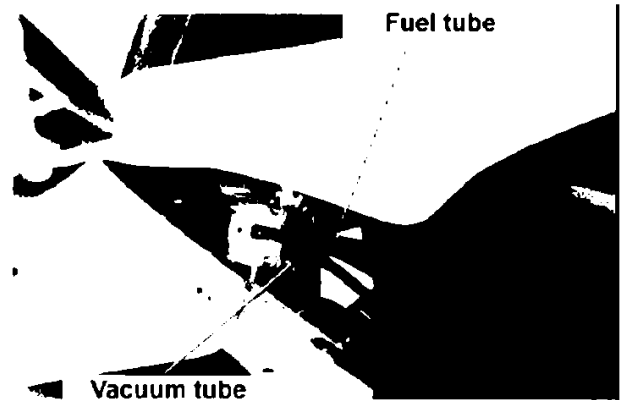
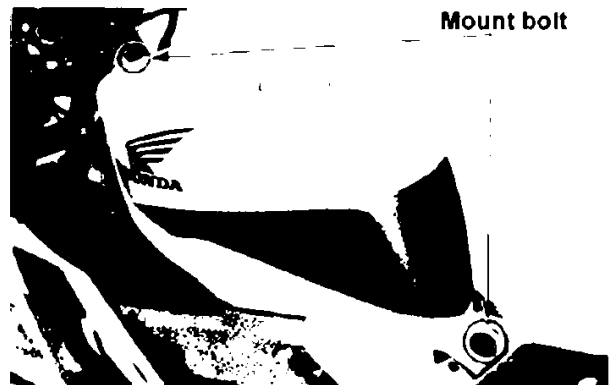

# CBR250RR (L)

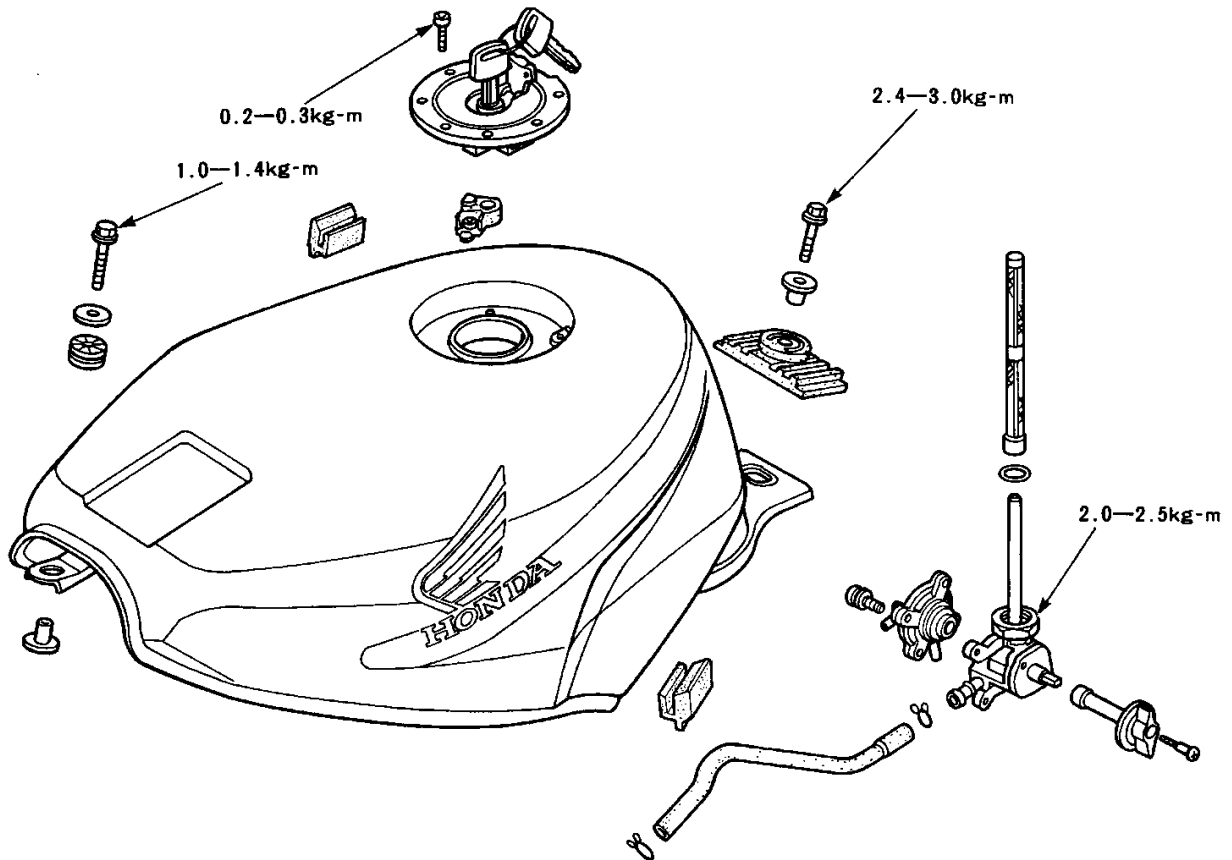

## Air Filter Case Removal

Remove the fuel tank (24-21).  
Unscrew to remove the air filter case cover.

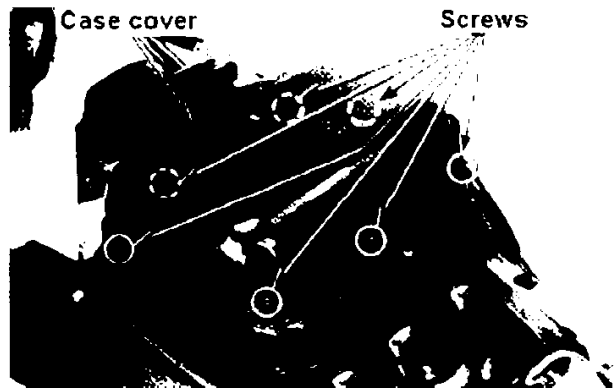

Remove the air filter element.  
Unscrew to remove air filter element bases.

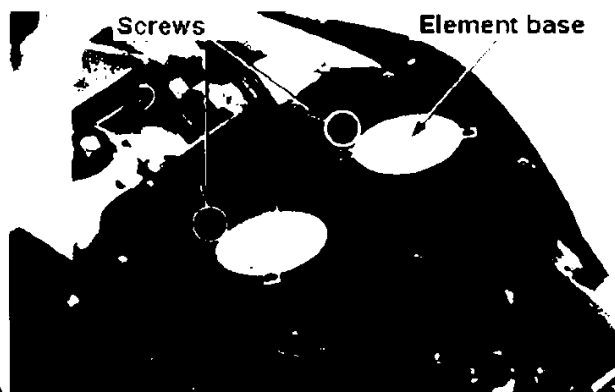

24-22

# CBR250RR (L)

Loosen the air filter upper case mount screws and the bolt.

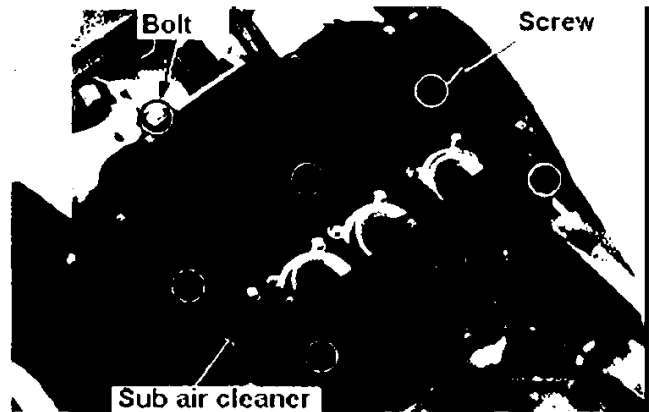

Lift up the air filter upper case to disconnect the breather tube. Remove the air filter upper case.

Set an air filter lower case to the carburettor to remove/install the case.

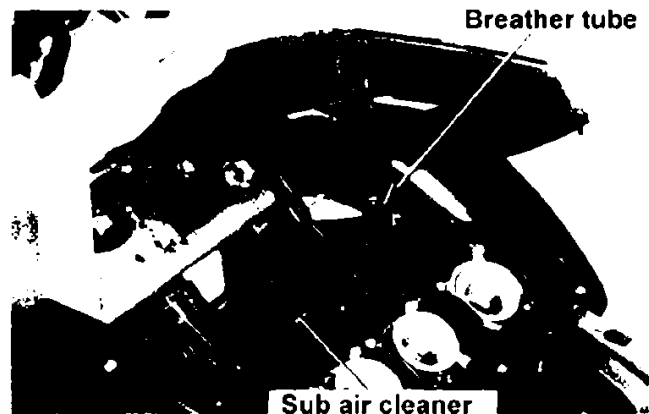

## Air Filter Case Installation

Follow the removal procedure in reverse order.

- Connect the breather tube to the air filter upper case.
- Firmly clamp the sub air filter tube.

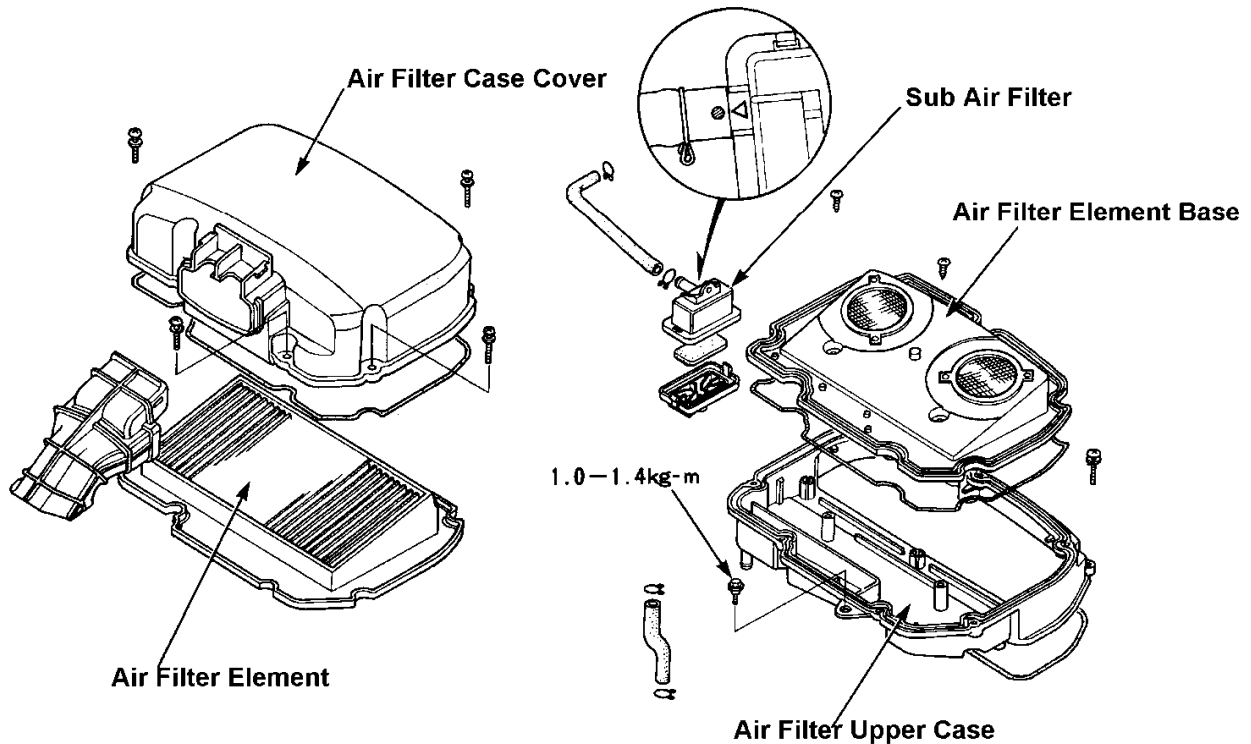

# CBR250RR (L)

## Carburettor Removal

Remove the fuel tank (24-21).  
Remove the air filter case (24-22).  
Unscrew the drain plug to drain fuel in the carburettor.  
Loosen four screws on the carburetor insulator band on the cylinder end.

### Caution

- Highly inflammable. Keep away from fire.
- Wipe off spilt fuel straight away.

Set the carburetor insulator to the carburetor to remove/install it.

Remove the throttle stop screw from the clamp.

Disconnect the throttle cable and a choke cable.  
Remove the carburetor.

Seal the intake manifold with adhesive tape after removing the carburetor.

## Disassembly

The carburetor need not be disassembled for the vacuum chamber / float chamber disassembly / assembly.

Remove the insulator from the carburetor.

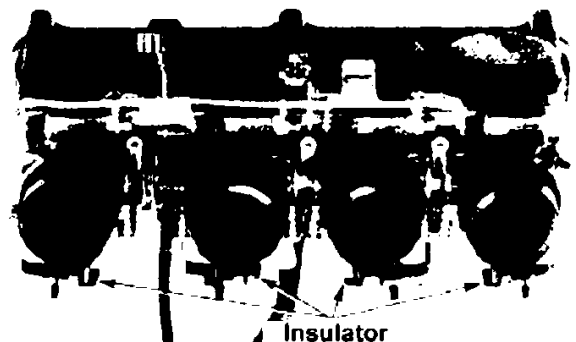
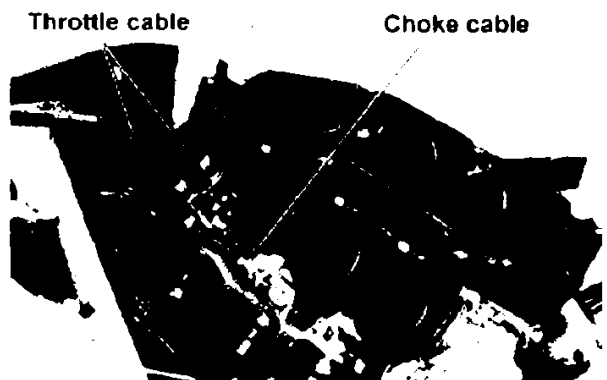
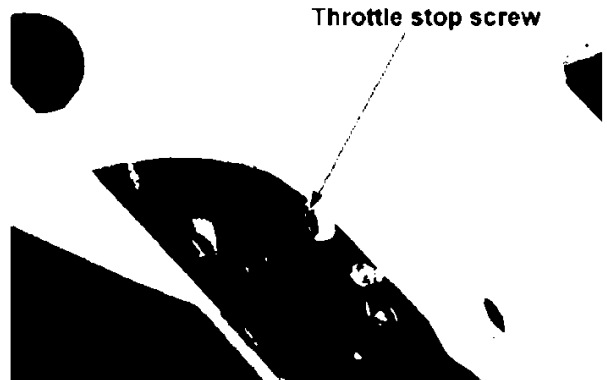
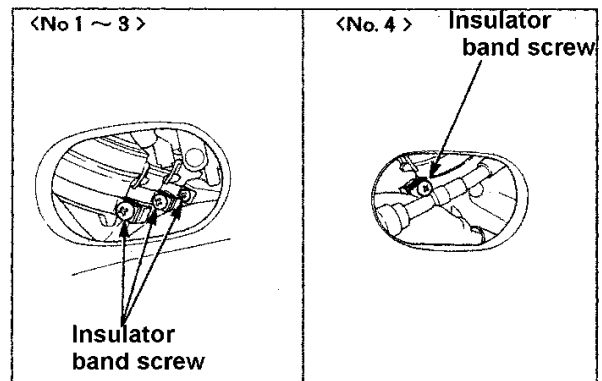

# CBR250RR (L)

Wind the throttle stop screw to have all carburettor bi-pass holes visible.

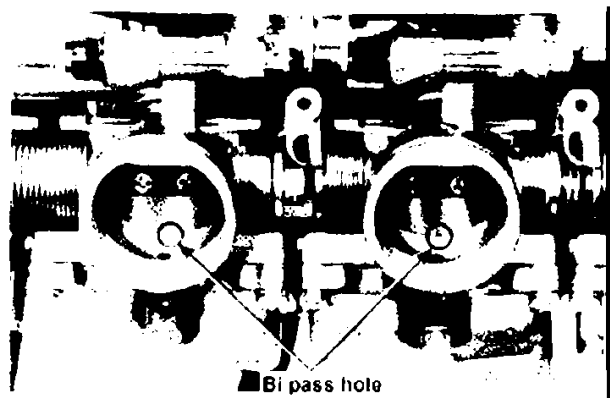

Unscrew bi-starter lever mount screws to remove the washer and the bi-starter lever. Remove the return spring, spring collar, and the spring.

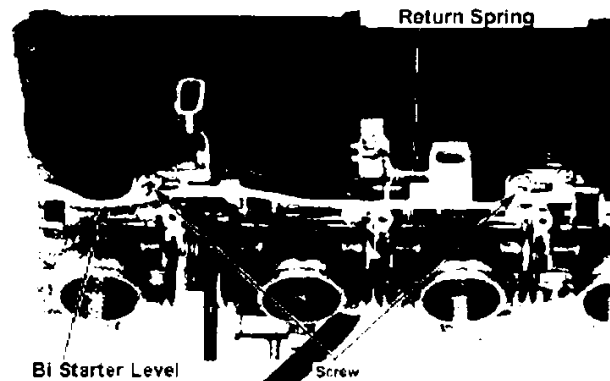

Lift a catch on the lock plate and unscrew the lock plate screws.

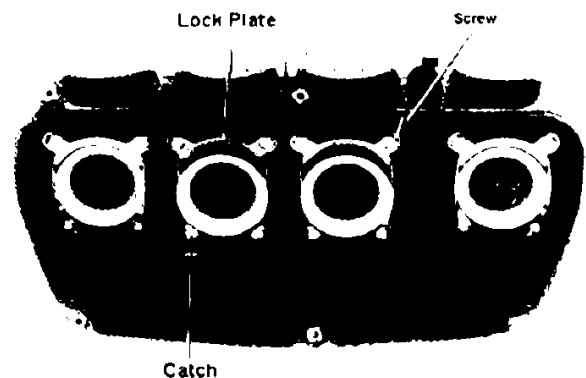

Remove the air filter lower case together with the air funnel.

Remove O-Rings.

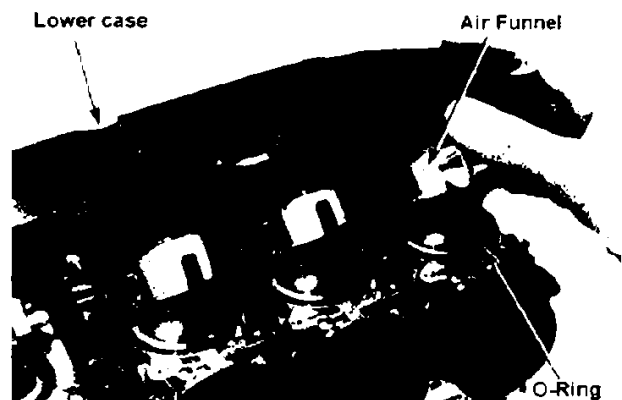

## CBR250RR (L)

Unscrew carburettor nuts and remove nuts on the left hand side.

Pull carburettor connecting bolts out to the right.

Separate the carburetors.

- Two carburettor thrust springs and three synchronisation adjust springs will come off at the same time. Do not lose them.
- Separate carburetors horizontally to avoid damaging the fuel joints and the air vent joints.

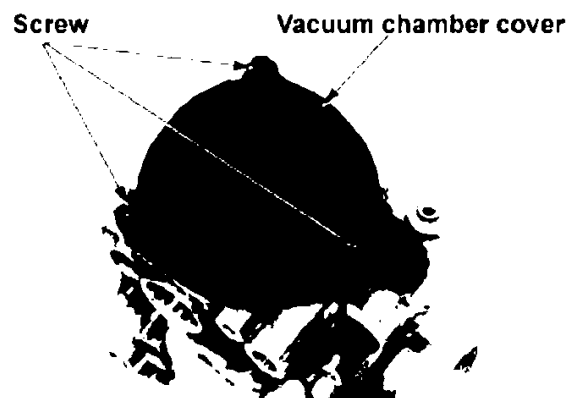
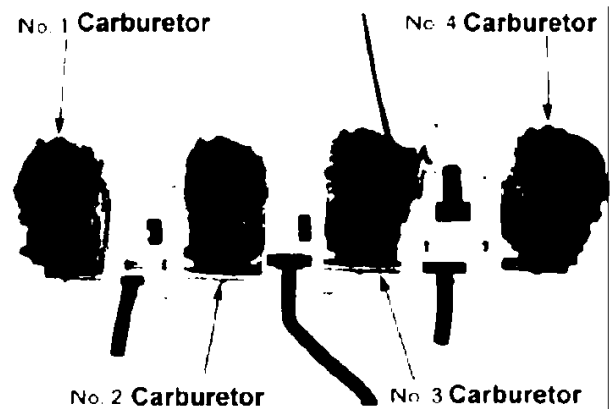

Unscrew vacuum chamber mount screws to remove the vacuum chamber cover.

Remove the spring and the vacuum piston. Check for the smooth operation of the piston in the chamber.

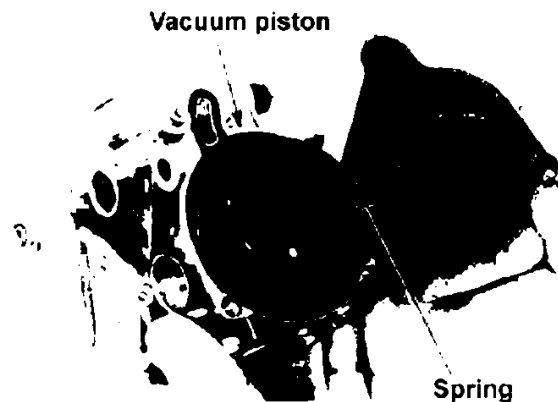

Screw the vacuum chamber cover mount bolt to the jet needle holder to pull the holder out. Remove the spring, jet needle and the washer from the piston.

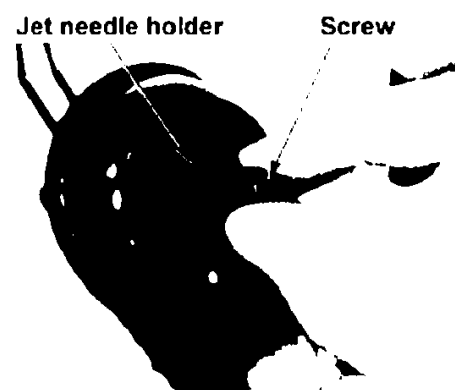

# CBR250RR (L)

---

Inspect the jet needle tip for wear, twist and damage.

Inspect the diaphragm for damage.

Inspect the vacuum piston for wear and damage.

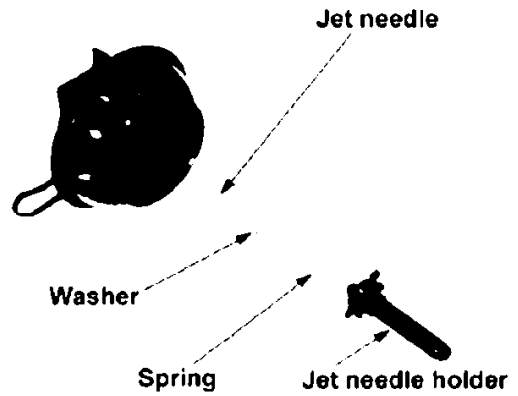

Unscrew float chamber mount screws.  
Remove the float chamber.

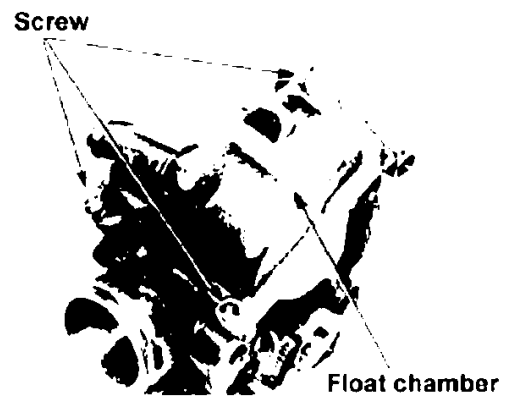

Remove the float pin to remove the float valve.  
Inspect the float.

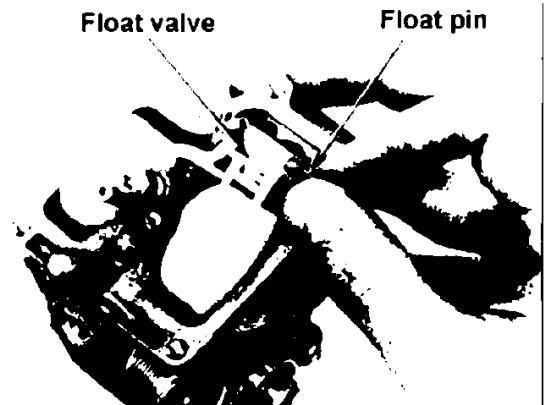

Inspect the float valve and the valve seat for blockages and damage.  
Inspect the valve seat contact area for wear.

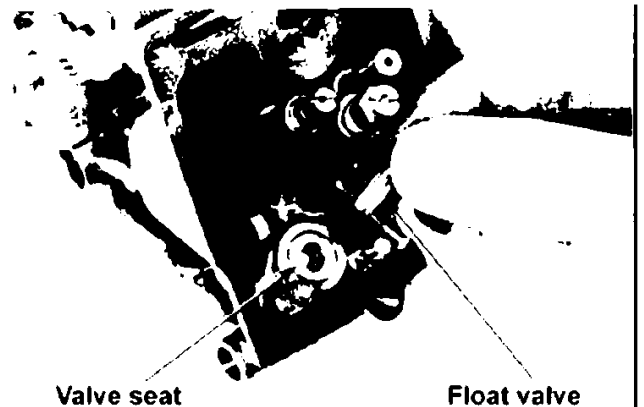



# CBR250RR (L)

Remove the main jet, the needle jet holder and the slow jet.

Record the number of winds to fully tighten the pilot screw, then unscrew. Remove the spring, the washer and the O-Ring.

Do not overtighten the pilot screw to avoid damaging the seat.

Clean the main / slow jets.

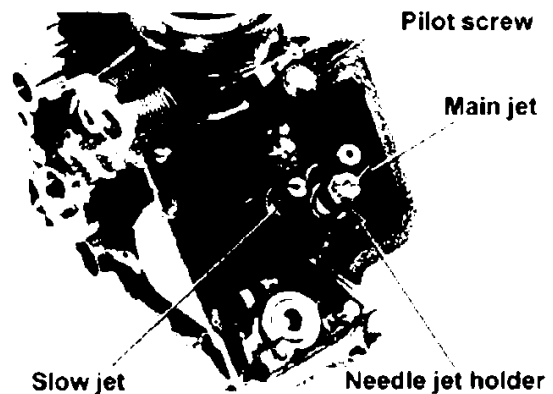

Loosen the bi-starter valve nut to remove valve spring and valve.

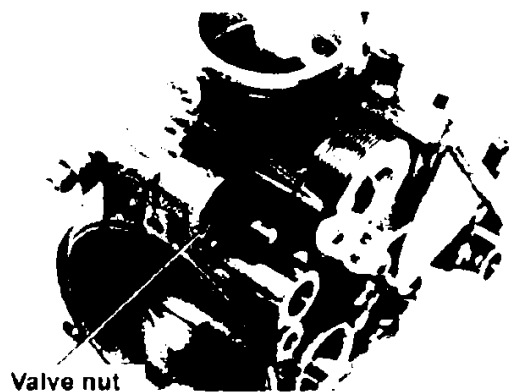

Insert the bi-starter valve to inspect , for unequal wear and damage. Inspect the valve spring for deformation and damage. Inspect the dust seal for damage.

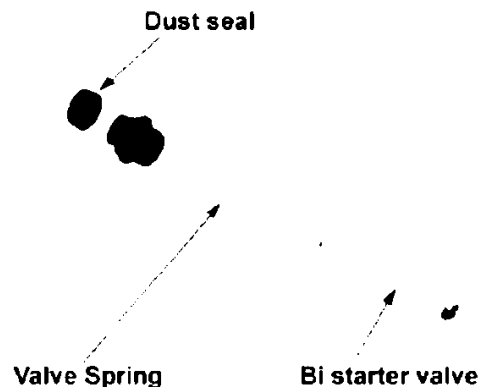

Clean the carburetor air passage with compressed air. Clean the threaded part of the air filter lower case. Clean the filter in a float valve seat with compressed air.



# CBR250RR (L)

## ◆ Assembly

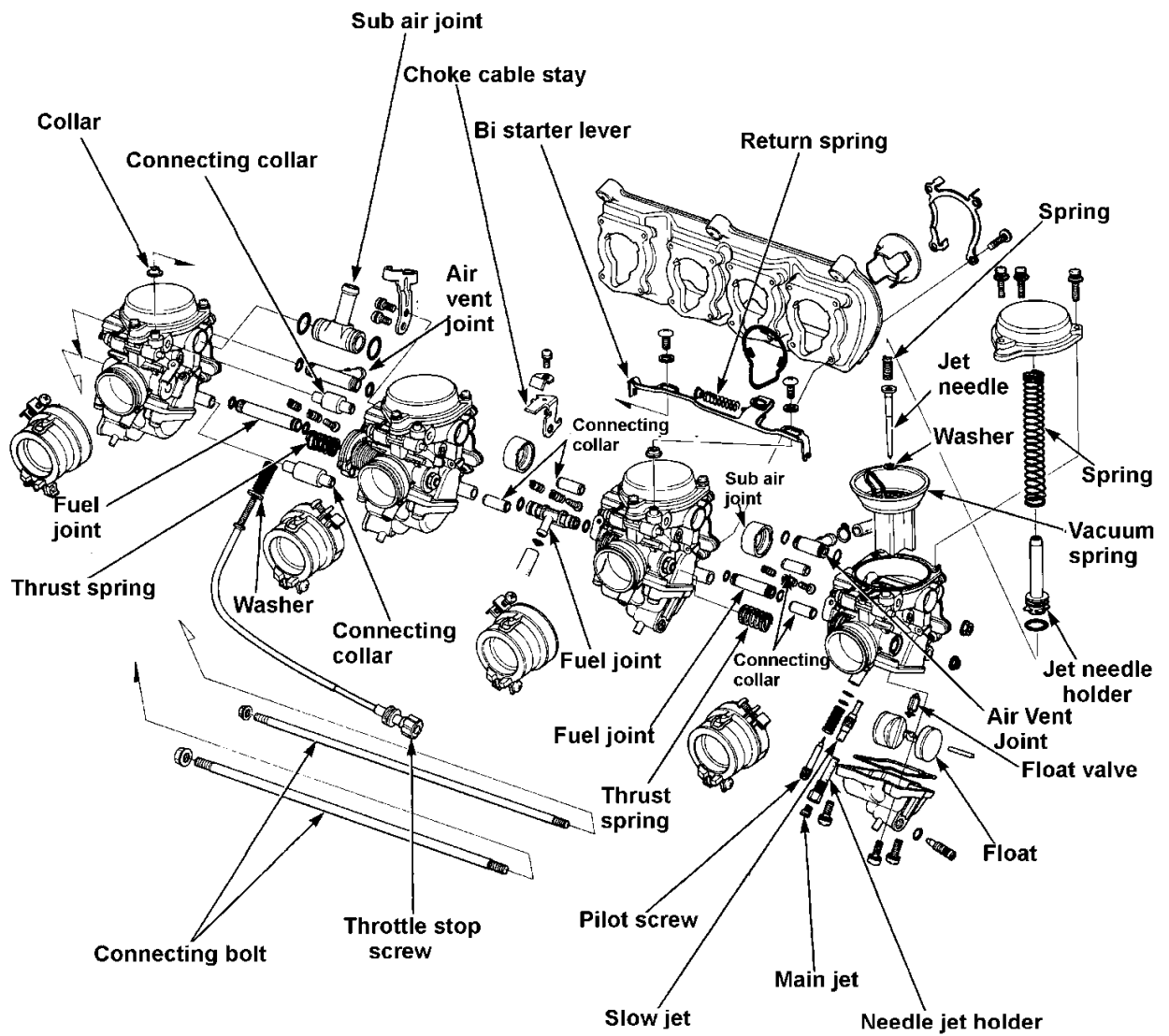

Install the bi-starter valve and the valve spring.  
Tighten the bi-starter valve nut.



# CBR250RR (L)

Install the needle jet holder, the main jet and the slow jet to the carburettor body.  
Install a washer, an O-Ring and the pilot screw to the carburettor body.

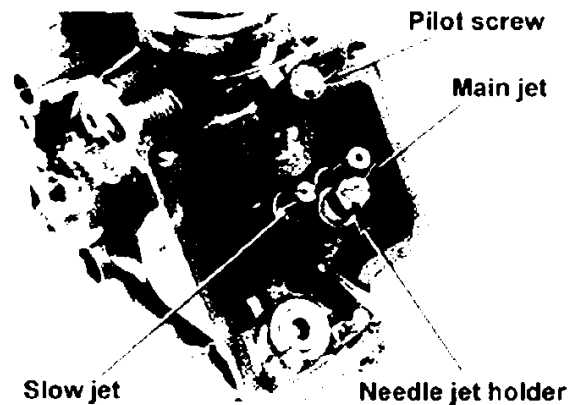

Install the float and the float valve to the carburettor body with the float pin.

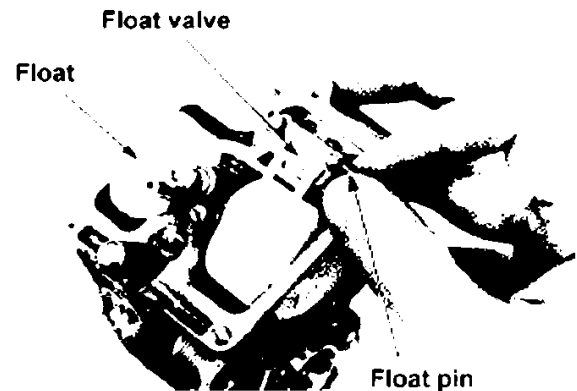

## Float level check

Hold the float chamber mount surface vertical and tilt the carburettor 30° from that position. Measure the float level at the position where the float valve and the float arm contact.

Standard float level: 13.7mm

Common Tools:  
Float level gauge: 07401-0010000

Place the gauge perpendicular to the float chamber mount surface at the main jet.

Install a new O-Ring to the float chamber and install the chamber.

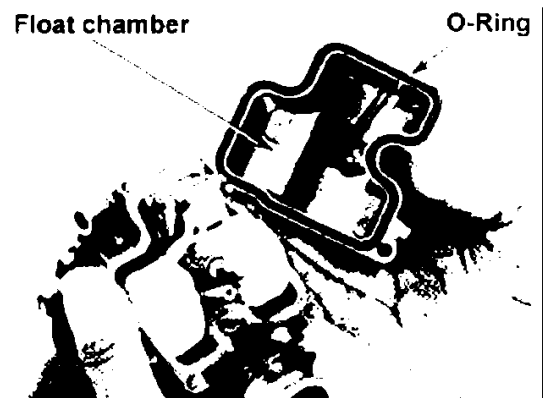
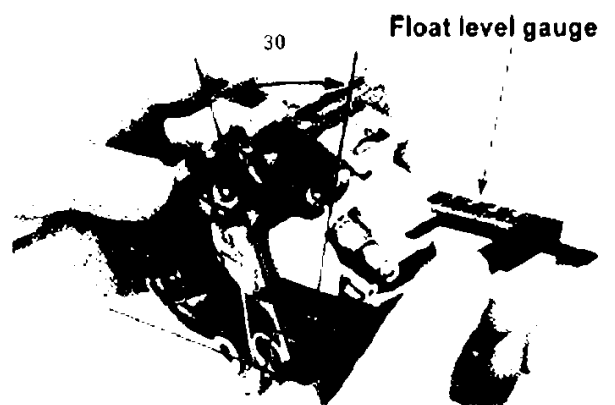

# CBR250RR (L)

Firmly tighten the three screws.

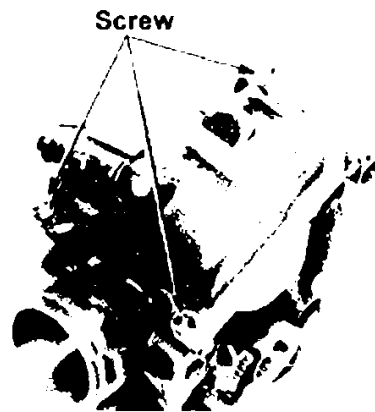

Install the washer, jet needle and the spring to the vacuum piston and push the jet needle holder into the piston.

Push the holder in until you can feel the O-Ring set to the slit.

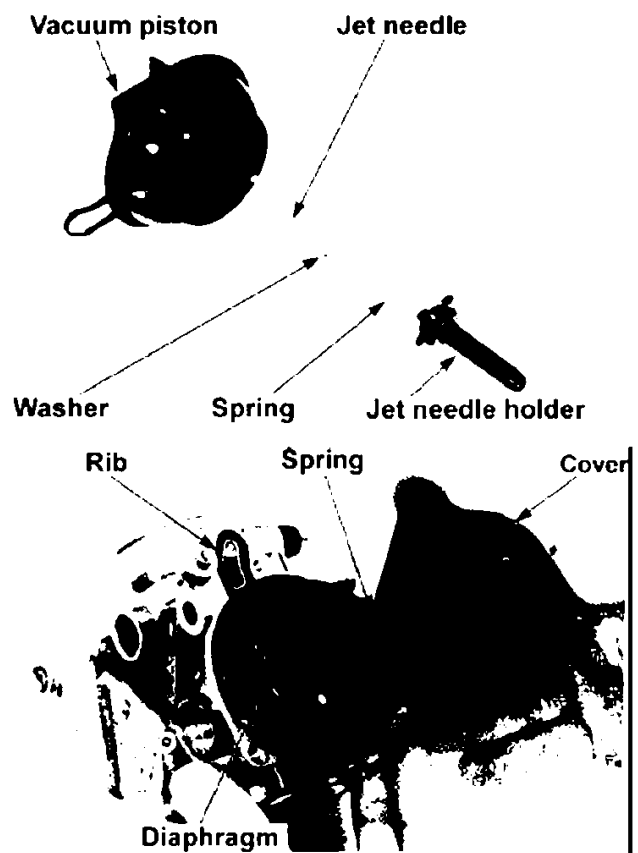

Push up the bottom of the vacuum piston toward the vacuum chamber (fully opened). Firmly set the rib of the diaphragm to the slit on the body.

Install the spring and the cover.

Do not catch the diaphragm.

Firmly tighten the three screws.

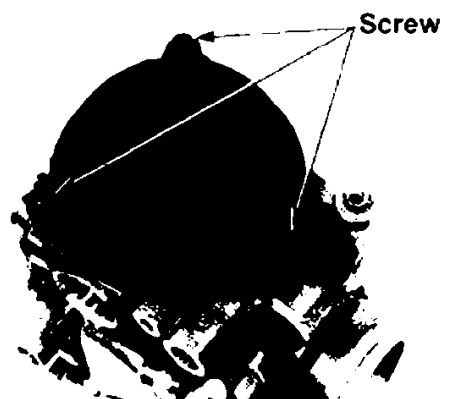

# CBR250RR(L)

Install #1 and #2 carburetors in the following manner.

Install new O-Rings to the air joint pipe and fuel joint pipe.

Joint the carburetors with a thrust spring, an air vent joint, a fuel joint and connecting collars.

Install a synchronization spring.

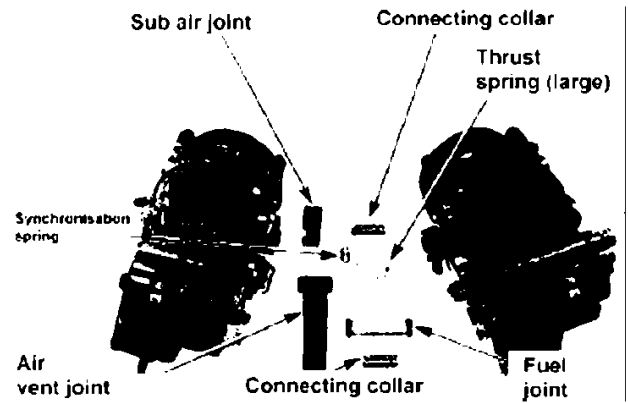

- When installing the sub air joint to #1 carburettor, set the joint slit to the body projection as shown in the photograph.
- Install the air vent joint so as to have its tube facing the air filter.
- Do not damage O-Rings when jointing parts.

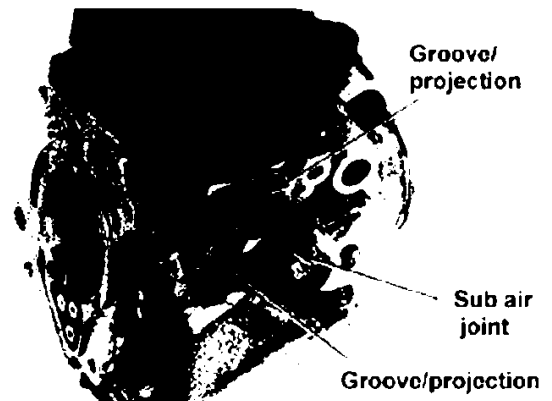

Install #3 carburettor in the same manner as #1 and #2.

- Do not use the thrust spring between #3 and #2 carburetors.
- Set a choke cable stay together with the top connecting collar.

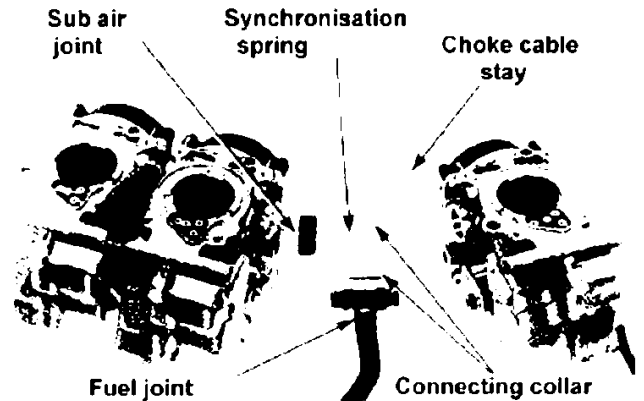

Install #4 carburettor in the same manner as #1 and #2.

Set the sub air joint so as to face it towards the vacuum chamber cover.

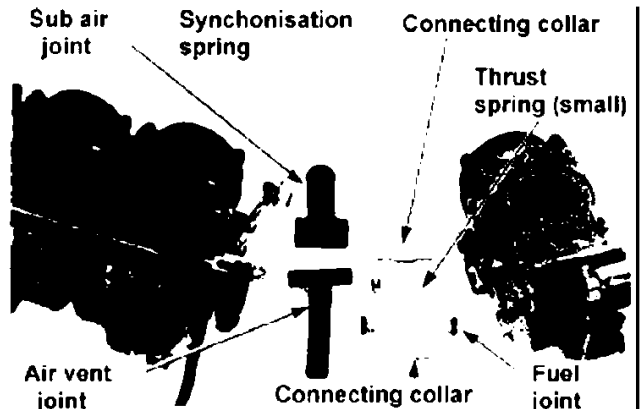

# CBR250RR(L)

Install carburettor connecting bolts from the right side.

Secure nuts.

Torque: M5 : 0.45 ~ 0.6kg-m

M6 : 0.8 ~ 1.2kg-m

## Caution

Strictly follow the torque setting.  
Overtightening may alter the carburetors separation.

Inspect the O-Rings and replace if worn/damaged.

Install O-Rings to the carburettor bodies.  
Install an air funnel together with the air filter lower case.

- Set new lock plates in advance.
- Set the slit of the air funnel to the projection on the carburettor.

Secure new screws and lock them by bending the catch of the lock plates.

Install collars to the carburettor bodies.  
Install the bi-starter lever to the bi-starter valve with the return spring and the spring collar.

Install the washer with the mount screw.

Connecting bolt (M6)

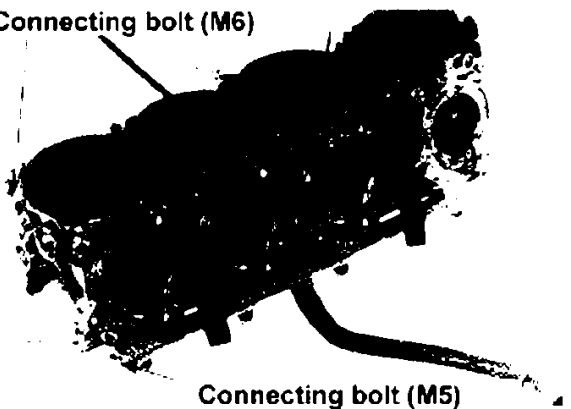

Connecting bolt (M5)

Lower case



O-Ring

Lock plate



Groove/projection

Lock plate

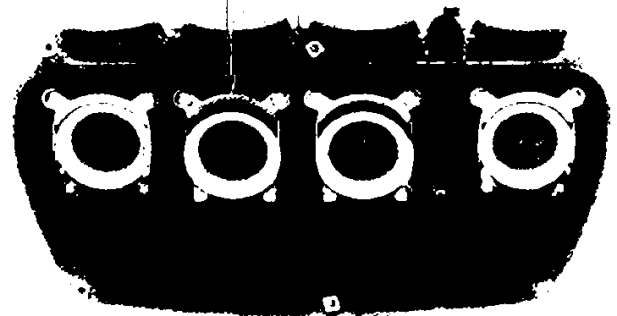

Spring collar

Screw

Return spring

Washer

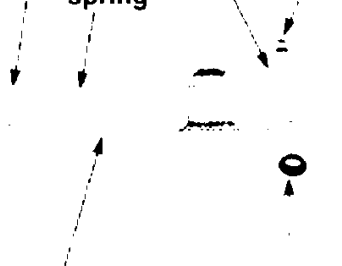

Bi starter lever

Collar

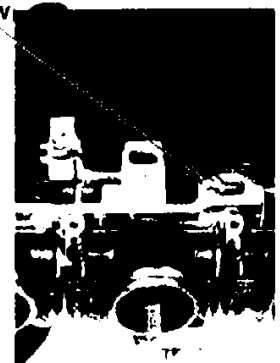

# CBR250RR(L)

Move the bi-starter lever to check the valve operation.

Check the throttle operation with the following procedure.

- Rotate the throttle drum to open the throttle a small amount. Check the smooth returning of the throttle.
- Open/close the throttle for its smooth operation.

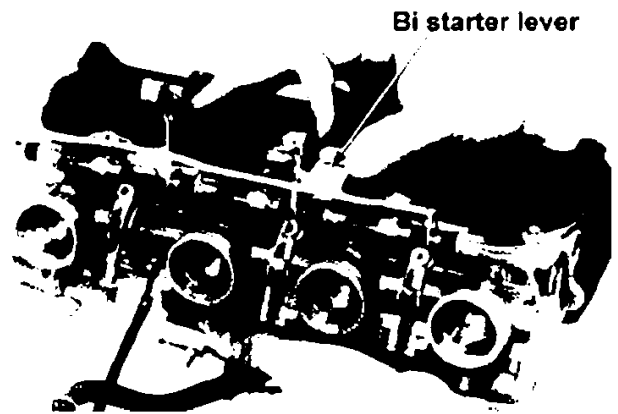

Wind synchronization adjust screws to align bypass holes of all carburetors with the throttle valve position.

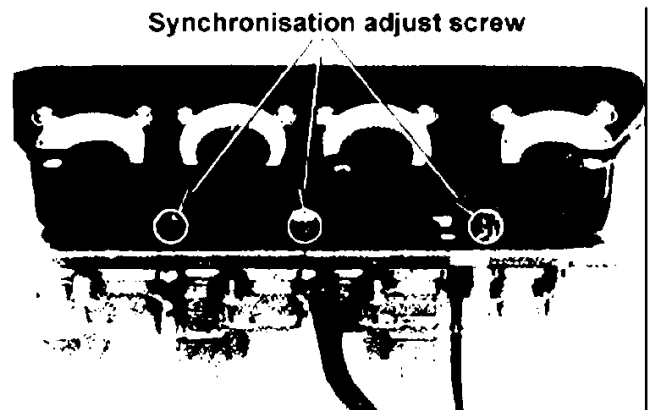

Use #3 carburettor as a reference.

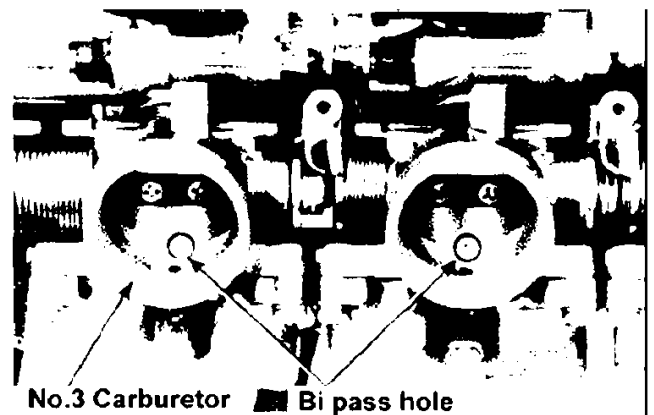

Install insulators to the carburetors.

Set the insulator strap screws correctly as shown in the photograph.

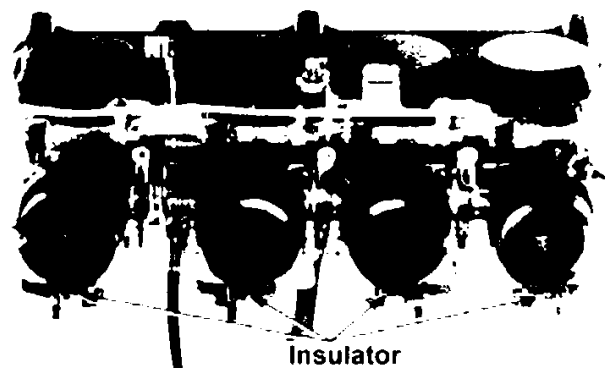

# CBR250RR(L)

## Carburettor Installation

Connect the choke cable and throttle cables.

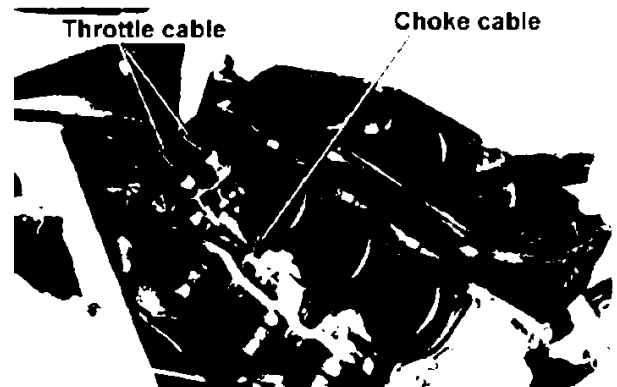

Install carburettors to cylinder heads and secure the insulator straps with screws.

Install the air filter case (24-23).

Install the fuel tank (24-21).

After installation, adjust the following items:

- Pilot screw adjustment (24-35)
- Throttle grip free play (2-16)
- Carburettor synchronization (24-36)
- Idling speed (2-10)

## Pilot screw adjustment

Remove lower cowls.

By using the following tool, wind the pilot screw to the end and wind back as recorded when disassembled.

Special tool: Pilot screw wrench: 07908-4220201

If the pilot screw or the body was replaced, wind back to the standard setting.

**Standard setting: 1 – ¾ winds.**

Do not overtighten the pilot screw or it may damage the seat surface.

## Carburettor synchronization

Adjust the synchronization after warming up the engine.

Apply vacuum to the auto cock (4-19).

Remove the fuel tank (24-22).

Remove rubber caps from #2 and #3 cylinder head intake parts and directly connects the rubber tubes of a vacuum gauge.

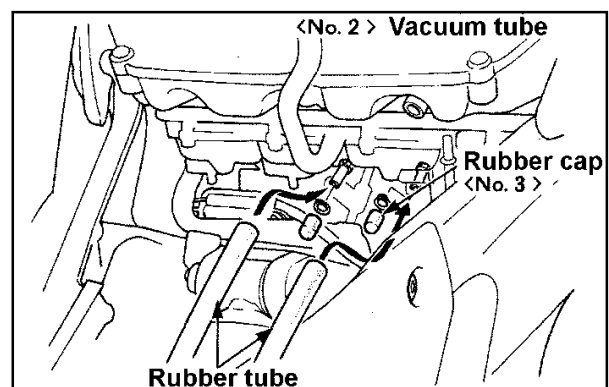
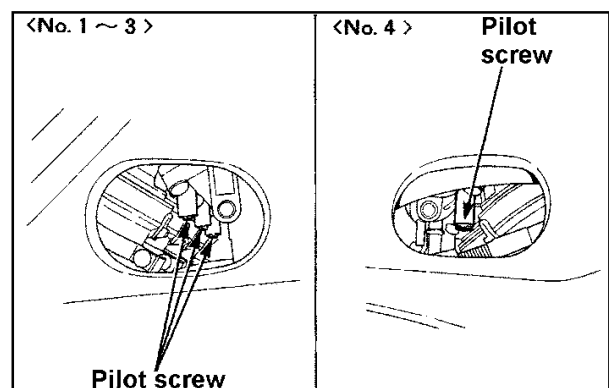
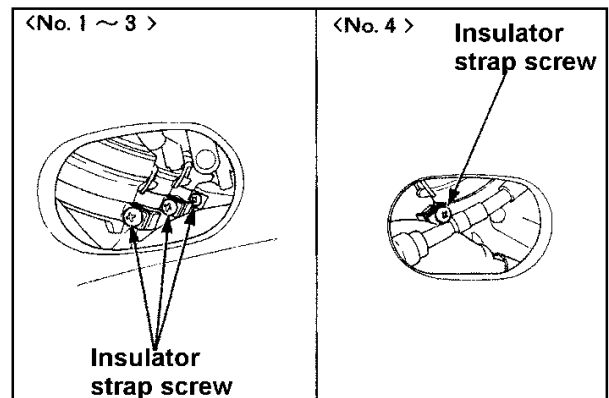



# CBR250RR(L)

Disconnect the vacuum tube from #1 cylinder head intake port and directly connect the rubber tube of a vacuum gauge.

Remove the plug and the washer from #4 cylinder head intake port and connect a genuine joint plug (part #16214-MBO-000).

Joint Plug: Genuine Honda 16214-MBO-000

Connect the rubber tube of the vacuum tube to the adapter.

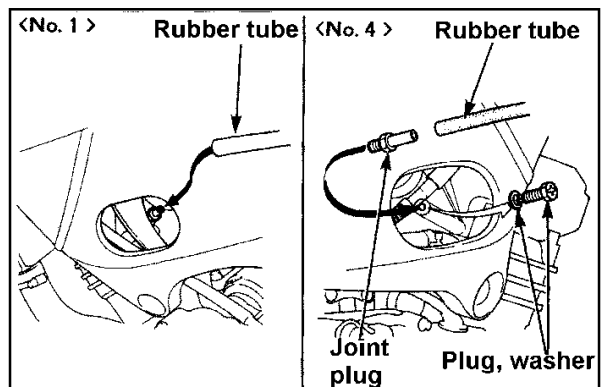

Start the engine and set it to the standard idling rpm.

**Idling rpm: 1500 ± 100rpm**

Measure the difference in vacuum between each cylinder.

**Standard vacuum difference: 40mmHg**

**Measuring Tool:**

**Vacuum gauge: 07404-0020000**

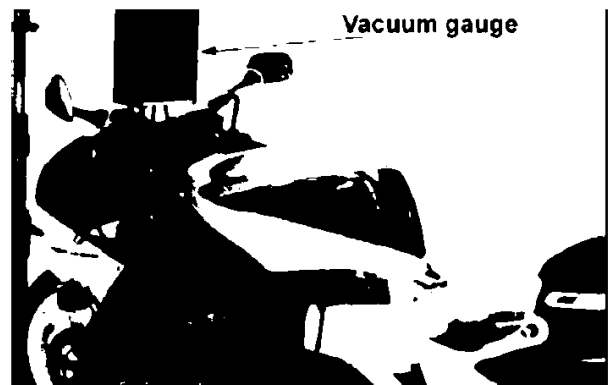

If the vacuum difference is above the standard, adjust in the following manner:

- 1) Confirm all pilot screws are rewound to the standard or recorded winds.
- 2) Wing adjust screws to adjust the synchronization.

Use #3 carburettor as a standard.

Re-check the synchronization and adjust the idling (24-35).

Install all parts by following the removal procedure in reverse order.

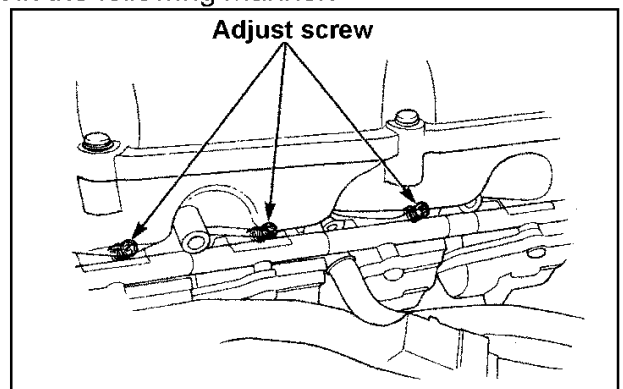

## Cooling System

### Thermostat removal

Remove lower cowls (24-59).

Drain radiator coolant by unscrewing the drain bolt.

Unscrew two bolts to remove the right air guide.

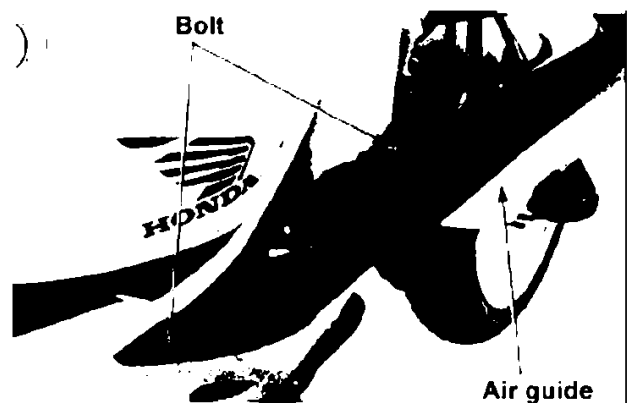

# CBR250RR(L)

---

Remove the radiator cap to drain coolant (5-3).

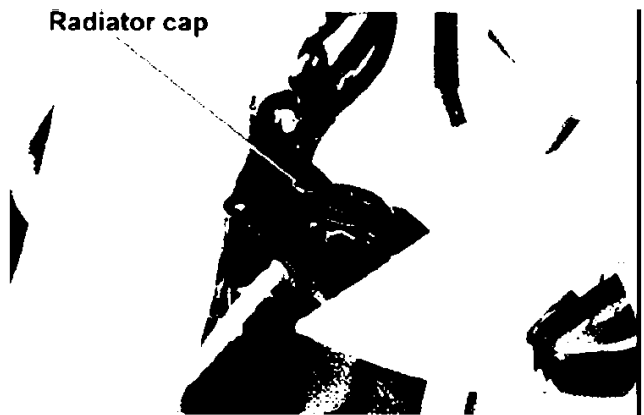

Unscrew two wire harness clamp mount bolts.

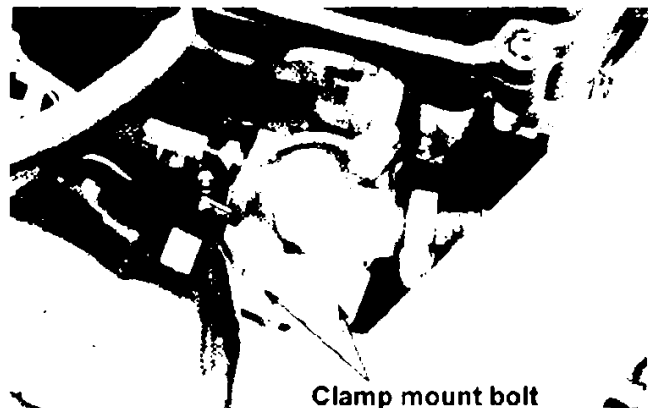

Unscrew two mount bolts to remove the thermostat upper case.

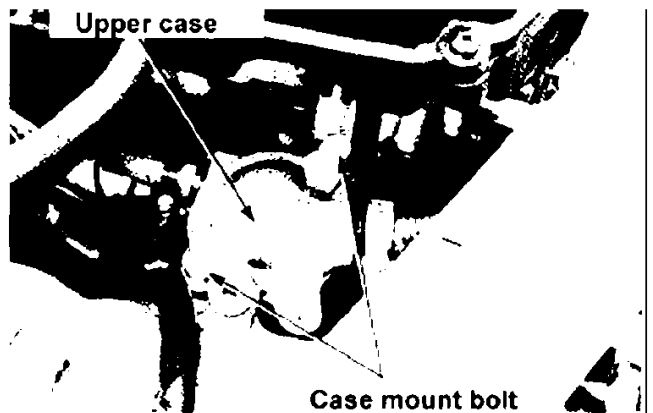

Remove the thermostat and the O-Ring.

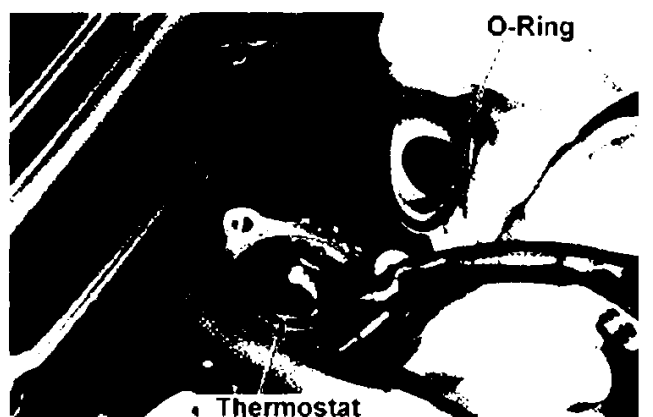

# CBR250RR(L)

## Thermostat Installation

Install the new O-ring to the thermostat upper case.  
Follow the removal procedure in reverse order for installation.

**Torque:**  
**Thermostat upper case: 1.0 ~ 1.4kg-m**

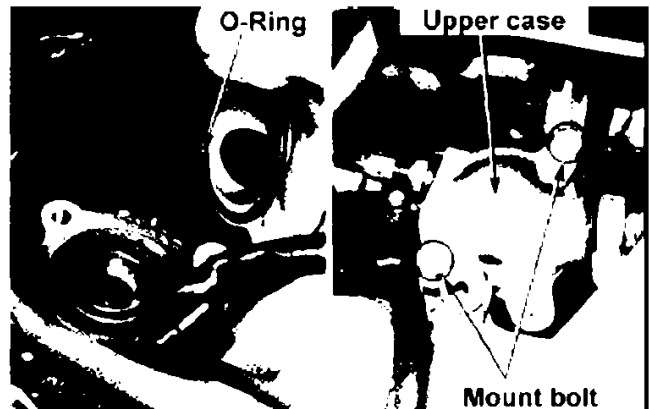

## Reservoir removal

Remove the rear cushion (24-50).  
Push the reservoir set spring and release the projection of the reservoir from the hole on the spring.  
Pull the reservoir back to remove the set spring.

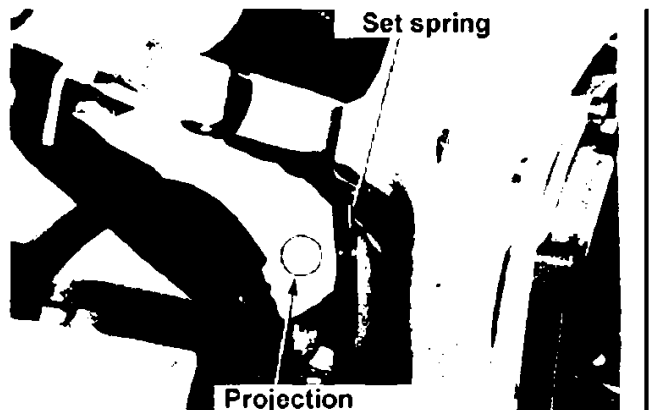

Release the projection on the left side of the reservoir from the hole on the frame.  
Disconnect the overflow tube.

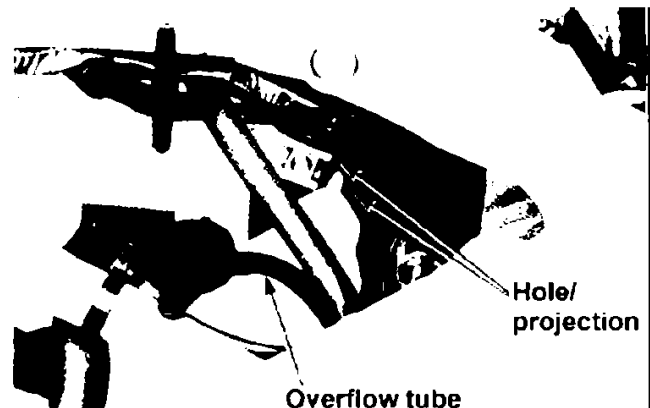

Disconnect the syphon tube.  
Remove the reservoir.

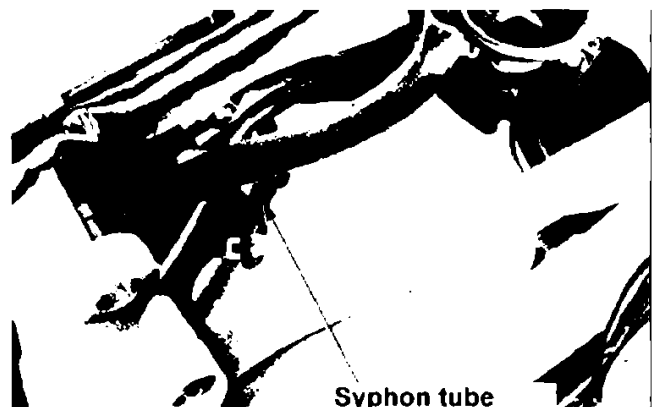

# CBR250RR(L)

---

## Reservoir Installation

Follow the removal procedure in reverse order for installation.

- Set the hole on the reservoir set spring to the projection on the frame.
- Refer to (24-8) for routing tubes.

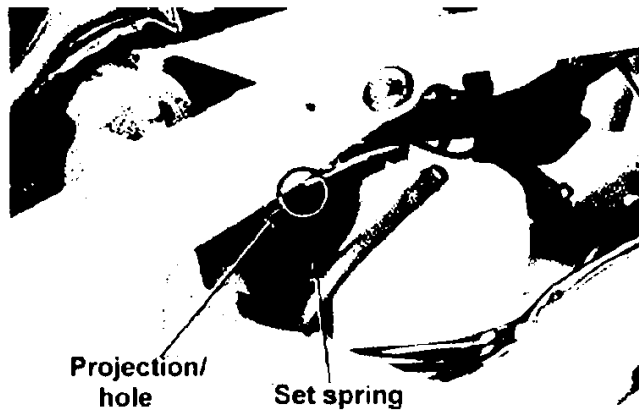

# CBR250RR(L)

## Engine Mounting / Dismounting

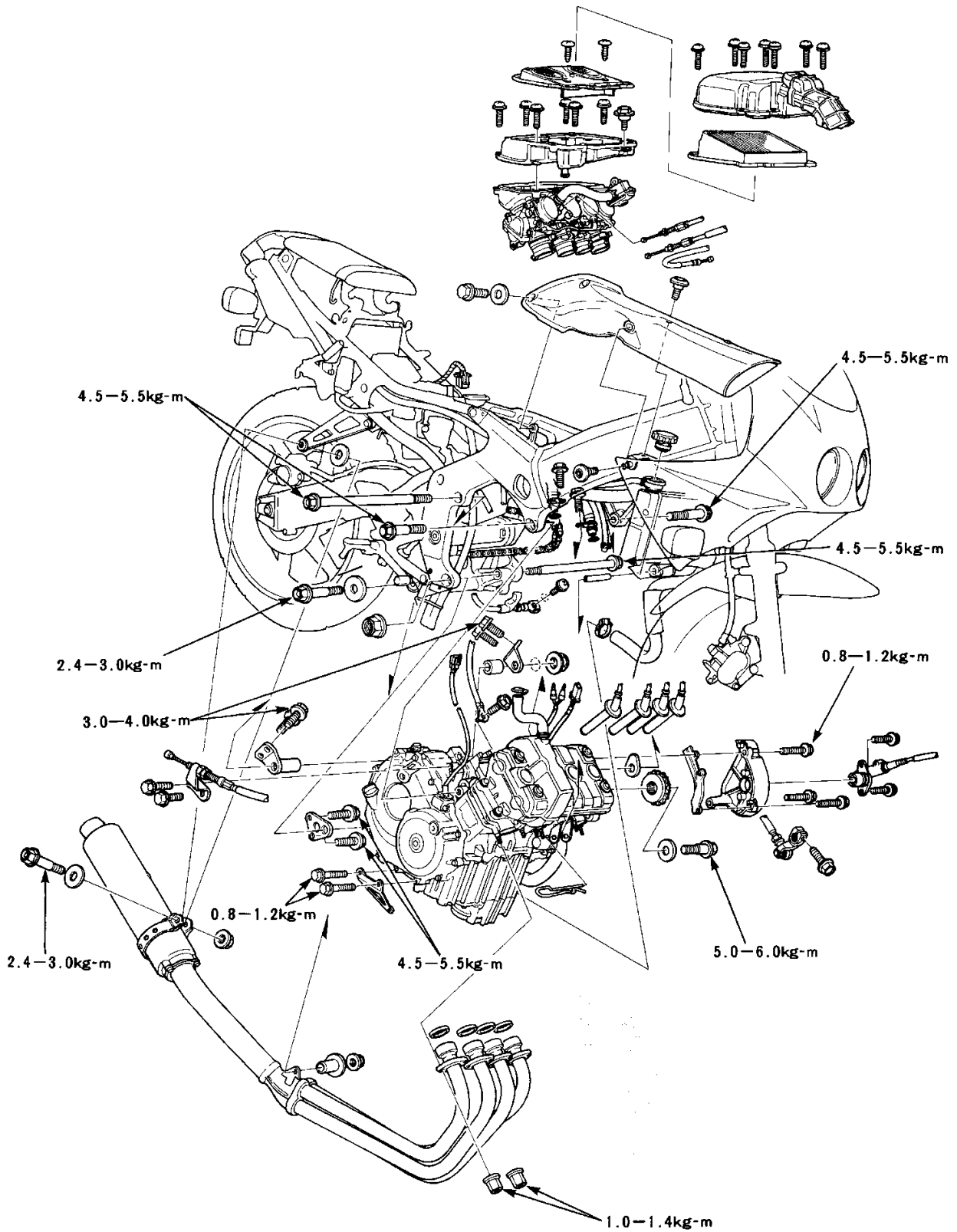

# CBR250RR(L)

## Engine Dismounting

- Drain engine oil (2-16).
- Drain radiator coolant (24-37).
- Remove the fuel tank (24-21).
- Disconnect the pulse generator coupler.
- Disconnect the neutral switch and the oil pressure switch connector.
- Remove carburetors (24-24).

Seal the intake manifold with adhesive tape.

- Remove two water hose mount bolts and disconnect the water hose from cylinders.
- Disconnect the earth cable and the terminal cable (6-2).

- Disconnect the alternator coupler.
- Disconnect the clutch cable (6-3).
- Disconnect the exhaust pipe (24-60).

- Remove the right lower cowl stay.

When dismounting the engine without removing the right lower cowl stay, do not bend the cowl stay.

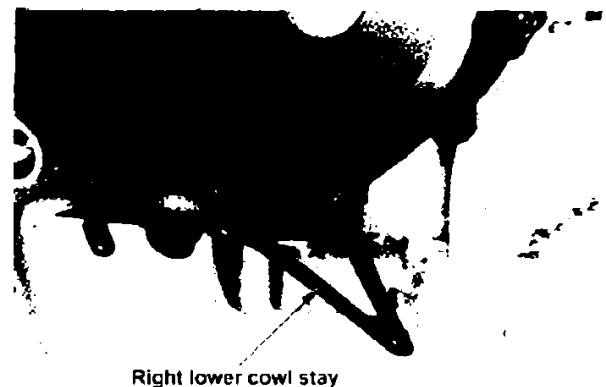
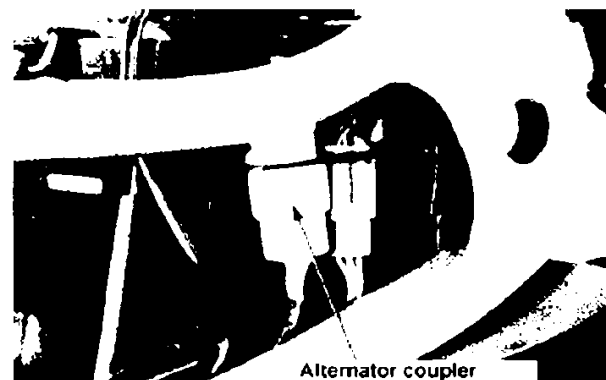
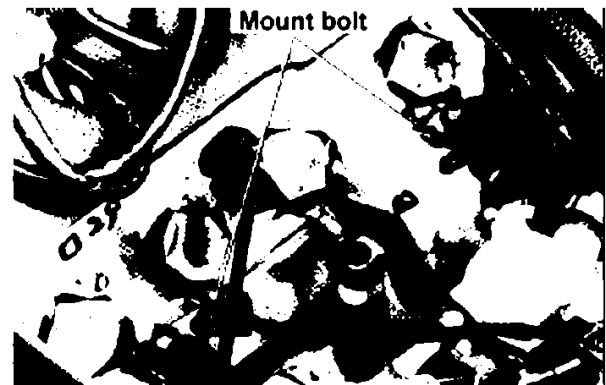
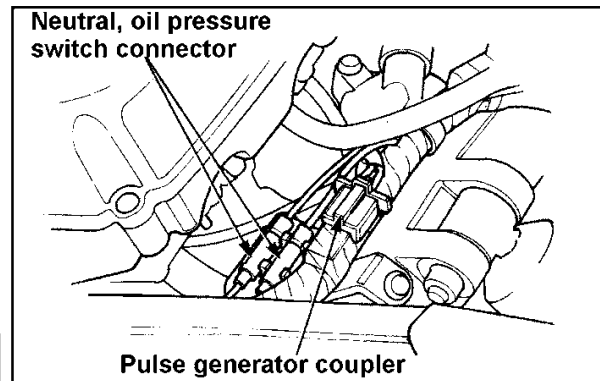

# CBR250RR(L)

Unscrew the bolt to pull the gearshift pedal arm out from the gear shift spindle.  
Remove the drive sprocket cover (6-3).  
Loosen the drive chain and unscrew the bolt to remove the drive sprocket and the washer.  
Disconnect the radiator hose and the bypass tube (6-3).

Remove the radiator set pin. Swing the radiator forward and fix it to the frame.  
Remove four plug caps.

Unscrew the front engine mount bolt from the right side.  
Remove the front engine mount bolt spacer and the nut from the left side.

Jack up the engine in advance.

Unscrew the rear upper engine mount bolt and the rear lower engine mount bolt to dismount the engine from the frame.

## Engine Mounting

Follow the dismounting procedure in reverse order.

- Install the rear upper engine mount bolt from the right side.
- Install the rear lower engine mount bolt from the left side.

## **Torque:**

Front engine mount bolt	4.5 – 5.5kg-m
Rear upper engine mount bolt	4.5 – 5.5kg-m
Rear lower engine mount bolt	4.5 – 5.5kg-m
Gear shift arm bolt	1.4 – 1.8kg-m
Drive sprocket bolt	5.0 – 6.0kg-m
Lower cowl stay bolt	0.8 – 1.2kg-m

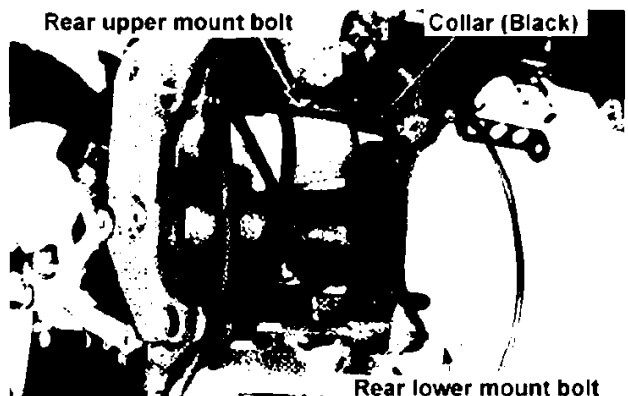
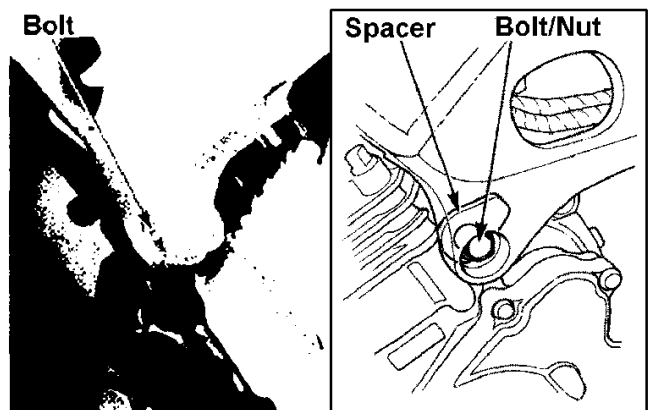
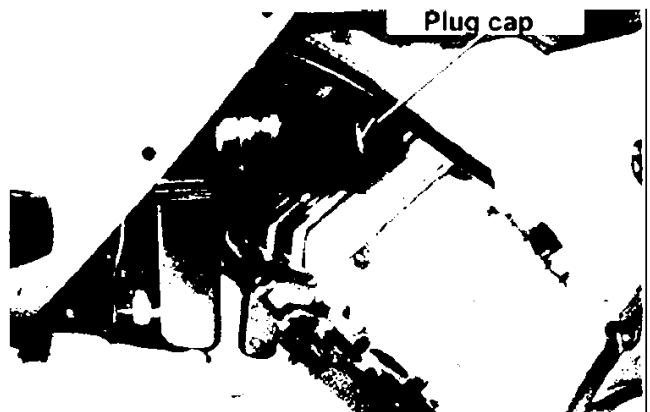
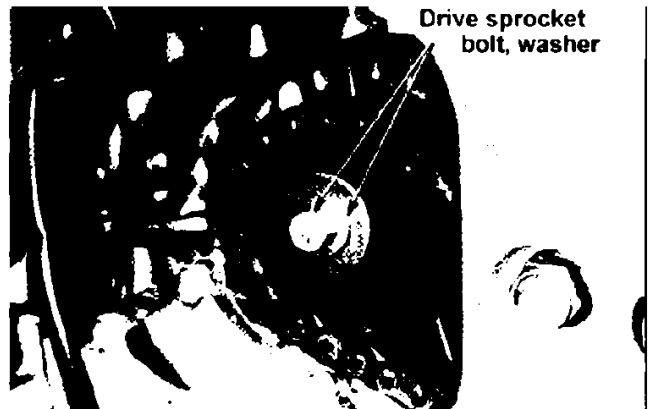

# CBR250RR(L)

Install the speedometer gearbox retainer by setting it to the drive sprocket bolt.

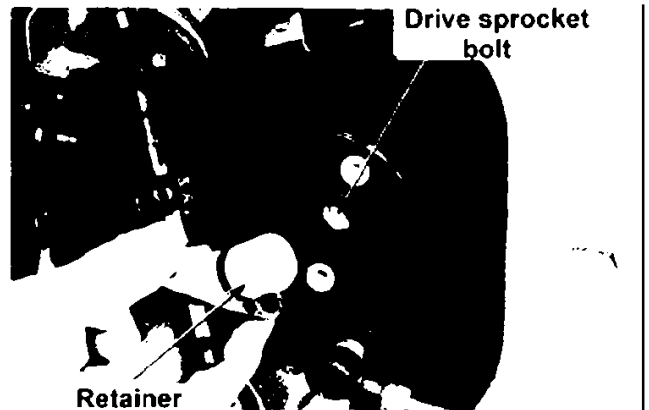

Install the new O-Ring to the hose joint and connect the water hose to cylinders. Screw the mount bolt for the oil pass pipe stay.

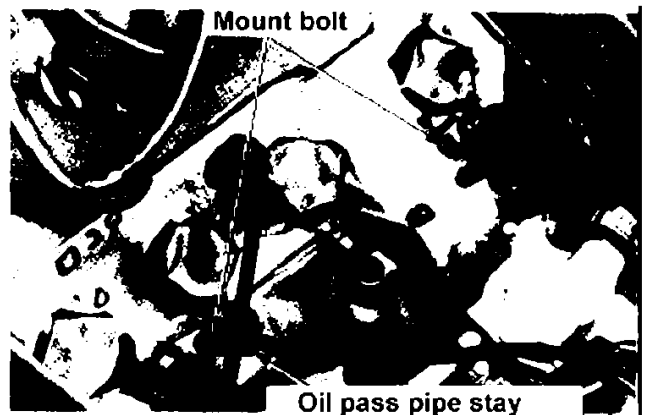

## Cylinder Head & Valve

### Cylinder head cover removal / installation

Remove both right and left lower cowls (24-59).

Remove both right and left lower guides (24-36).

Remove a radiator set pin and swing the radiator to the front.

Unscrew two mount bolts to remove the fan shroud and the fan motor in whole Assy. Remove plug caps.

Remove the fuel tank (24-21).

Remove the air filter case cover (24-22).

Disconnect the ignition coil mount bolt to remove the ignition coil and the heat guard plate in whole Assy to the bottom.

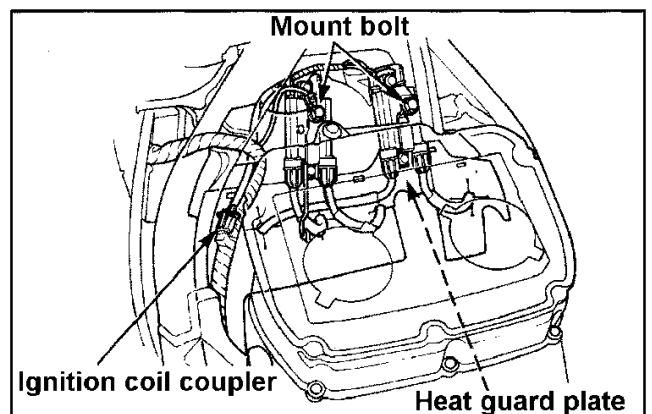
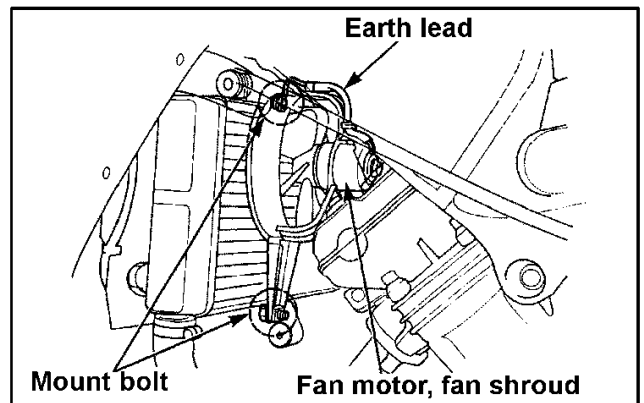



# CBR250RR(L)

Unscrew bolts to remove the cylinder head cover.

Follow the removal procedure in reverse order.

- Note there are “UP” marks on each washer.
- Tighten the top fan shroud mount bolt together with the earth lead.
- Screw the bolts at “▼” marks (two) on the head cover first, then the rest.
- When dismounting cylinder head / cylinder block, install the oil orifice so as to have smaller hole at the bottom.

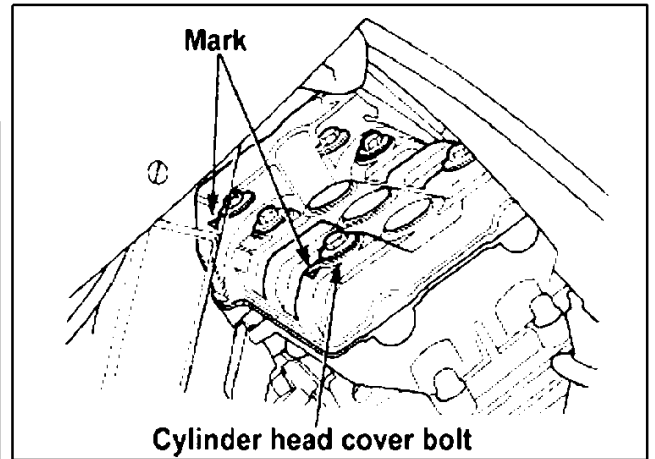

## Torque:

Cylinder head mount bolt: 0.8 ~ 1.2kg-m

## Cylinder, Piston and Crankshaft Bearing inspection and selection

- Crank pin bearing

Avoid the oil hole and place a plasticine gauge. Install connecting rods and bearing caps to each crankpin.

Apply oil to threads and seats and screw nuts (9-6).

Torque: 1.6 ~ 2.0kg-m

Do not rotate the crankshaft or the connecting rod while measuring.

Remove the bearing cap and select the plasticine size.

Oil clearance service limit:  
0.05mm or above → replace.

Replace the bearing if the oil clearance is above the service limit (9-7).

Find out the colour code of the bearing from the code numbers on the crankpin and the connecting rod.

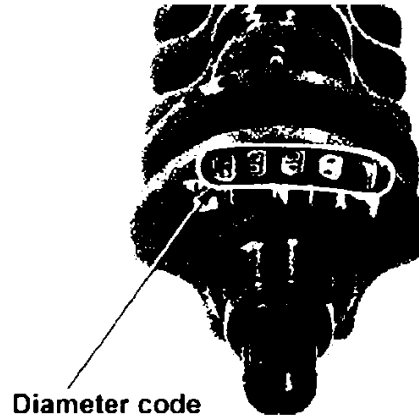

Bearing metal thickness	A (Blue) B (Black) C (Brown) D (Green) E (Yellow)	Thick ↕ Thin	Connecting rod bore code		
			30.000 – 30.006	30.006 – 30.012	30.012 – 30.018
Crankpin diameter code	27.500 – 27.494	A	E (Yellow)	D (Green)	C (Brown)
	27.494 – 27.488	B	D (Green)	C (Brown)	B (Black)
	27.488 – 27.482	C	C (Brown)	B (Black)	A (Blue)

# CBR250RR(L)

## Gear shift Linkage

### Gear shift pedal removal

Loosen the lock nut to remove the tie-rod bolt.  
Unscrew the left step holder bolt to remove the left step holder.

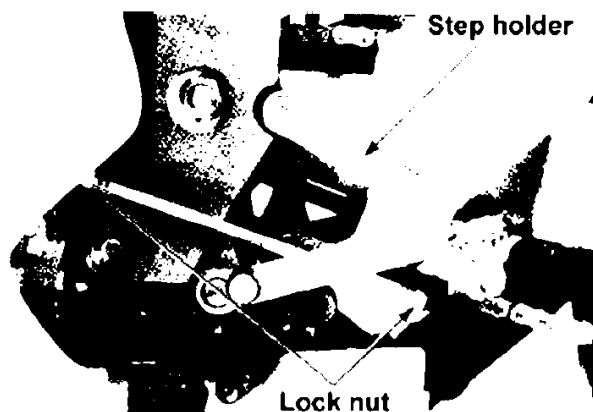

Unscrew the step pivot bolt to remove the gear shift pedal, step and the thrust washer.

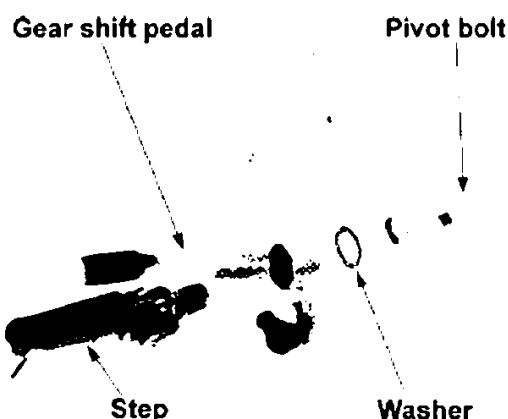

### Gear shift pedal installation

If the step pivot bolt was removed, replace the bolt and clean the thread.

Apply grease to the interior surface of the gearshift pedal bush.

Install the pedal and the thrust washer to the step.  
Set the step pivot to the slit on the step holder.  
Screw the new step pivot bolt.

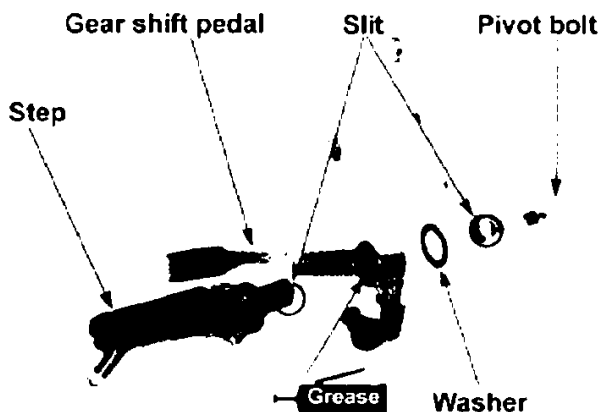

**Torque: 3.5 – 4.5kg-m**

Install the left step holder and screw the holder bolt.

**Torque: 2.4 – 3.0kg-m**

Install the tie-rod bolt to adjust the height of the gearshift pedal.

Screw the lock nut.

**Torque: 0.08 – 0.1kg-m**

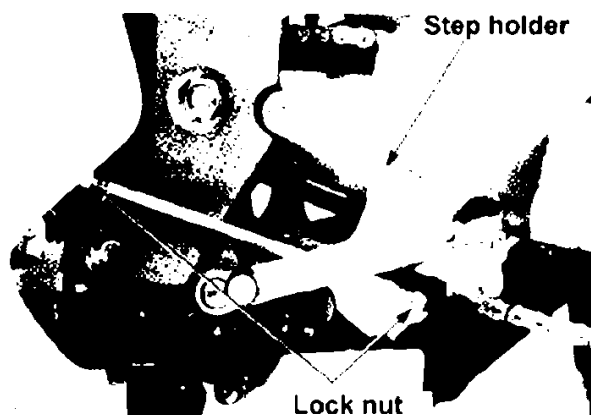

# CBR250RR(L)

## Front Wheel, Suspension and Steering

### Handlebar removal

Loosen the right top bridge bolt.  
Unscrew the left top bridge bolt.  
Remove the steering stem nut and the washer.  
Remove the top bridge.

The ignition switch may be left installed.

Remove the following parts:

- Handlebar switch case
- Throttle grip
- Master cylinder
- Left handlebar lever bracket

Unscrew handlebar mount bolts to remove the handlebar from the fork pipes.

### Handlebar Installation

Install the handlebar to the fork pipes.

Press the handlebar to the stopper rings on the fork pipes.

Install removed parts (13-7).  
Install the top bridge.

Set the positioning boss on the handlebar to the slits on the top bridge.

Install the steering stem nut and the washer.

**Torque: 9 – 12kg-m**

Screw the right top bridge bolt.

Screw the left top bridge bolt together with the choke cable guide.

**Torque: 2.0 – 2.5kg-m**

Screw the handlebar mount bolts.

**Torque: 2.4 – 3.0kg-m**

Refer to (24-6) to route the choke cable.

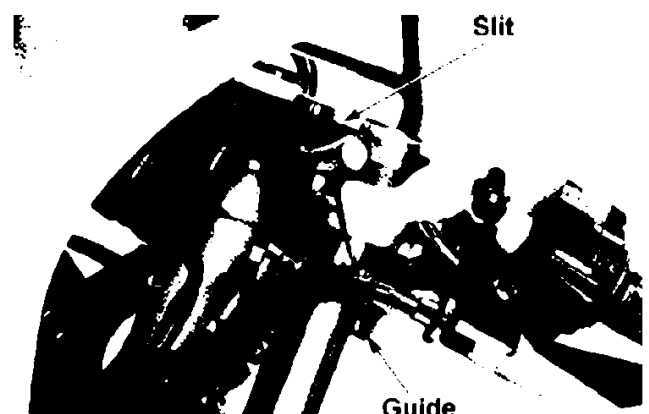
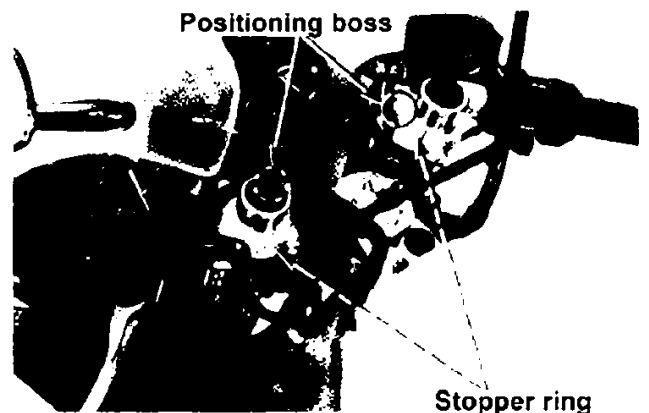
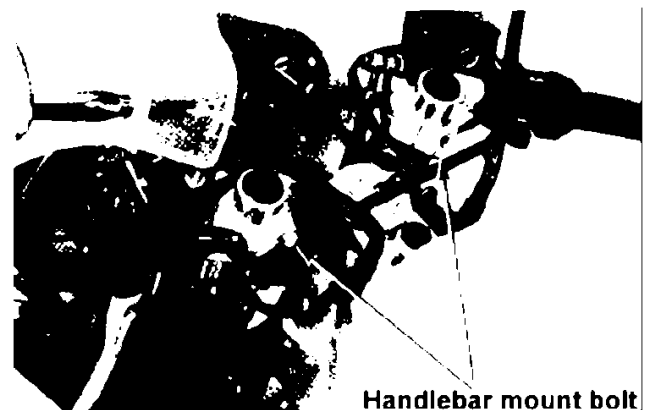
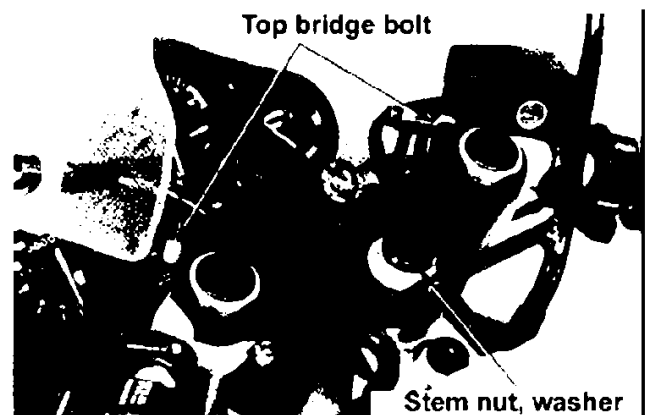

# CBR250RR(L)

---

## Cushion Spring Installation

Set the cushion spring so as to have its tapered end at the bottom

Wipe off all fork oil on the spring before installing.

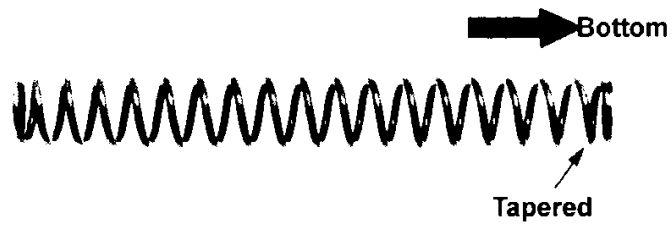

# CBR250RR(L)

## Rear Wheel and Suspension

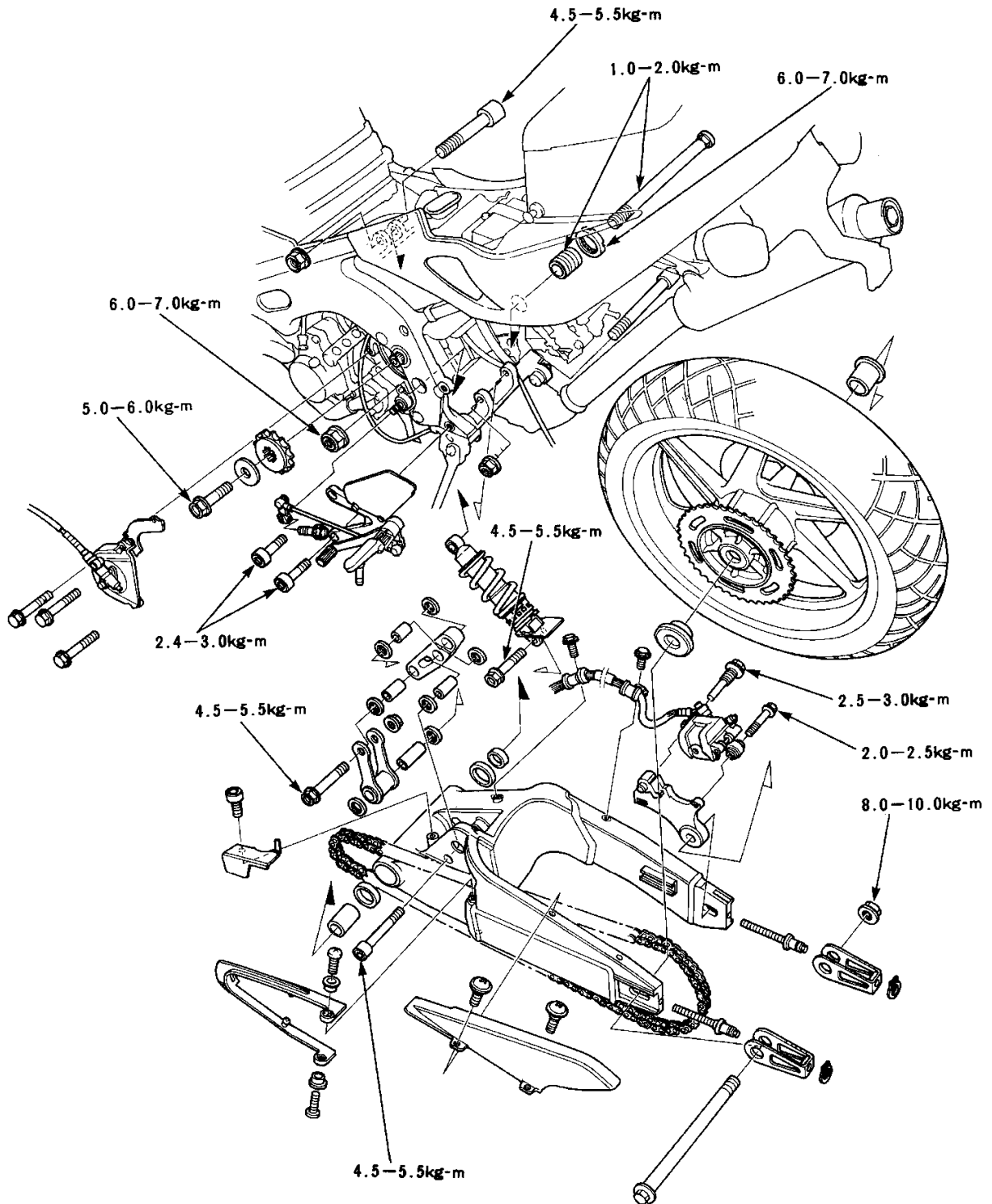

# CBR250RR(L)

## Drive Chain Replacement

Remove lower fairings (24-58).  
Remove the drive sprocket cover (6-3).  
Unscrew chain slider mount screws.

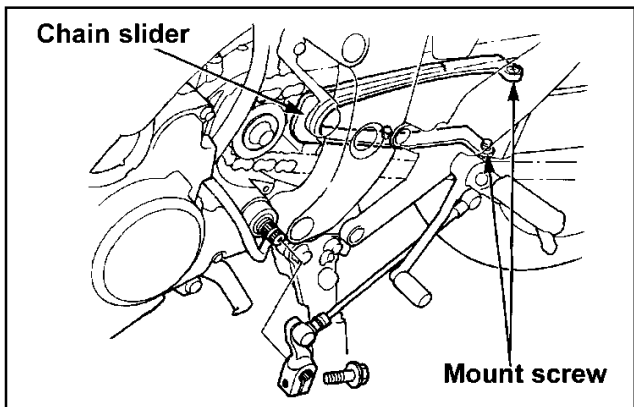

Remove the chain slider from the projection at the front part of the rear fork to replace.

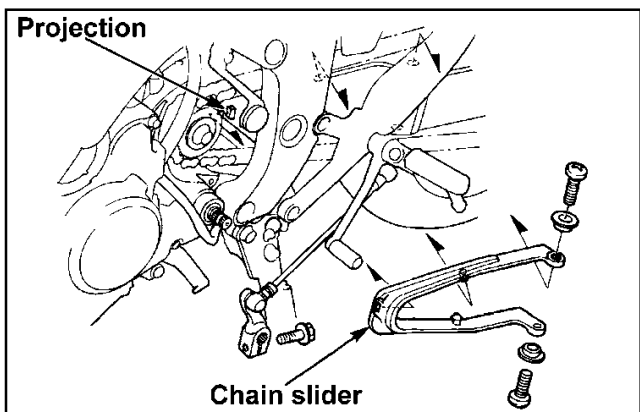

Screw chain slider mount screws.  
Install the drive sprocket cover (24-44).  
Install lower fairings (24-59).

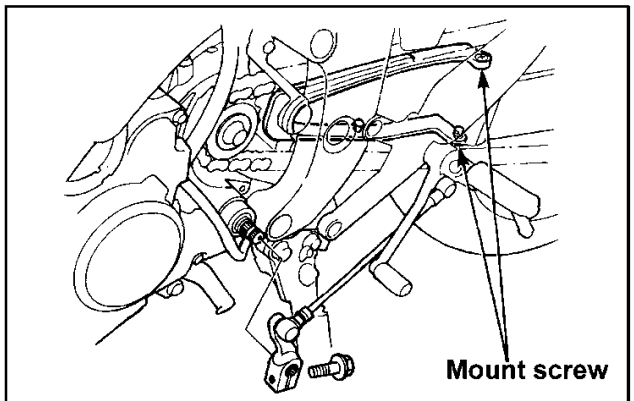

## Rear Wheel Bearing Replacement

Remove wheel bearings (14-5).  
Install the right bearing first.  
Insert the distance collar.  
Install the left bearing.

- Insert the right bearing to the stopper.
- Face the labeled surface of the bearing outward.

### Common Tools:

Driver handle A	07749-0010000
Outer driver (37 x 40mm)	07746-0010200
Pilot (17mm)	07746-0040400

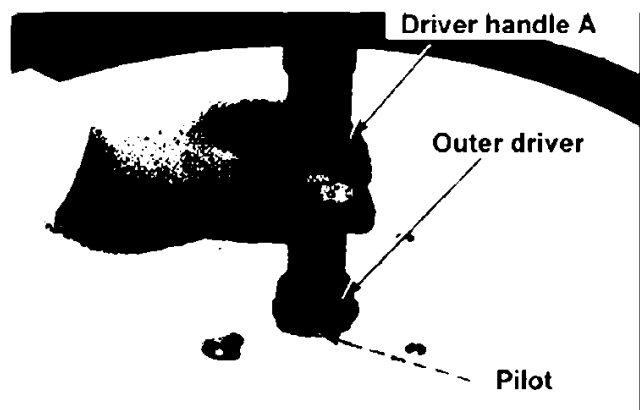

# CBR250RR(L)

## Rear cushion removal

Support the frame to lift the rear wheel.  
Remove the fuel tank (24-21).  
Unscrew the rear cushion lower bolt.  
Unscrew the rear cushion upper bolt.  
Remove the rear cushion.

Clean the female thread of the lower joint whenever the rear cushion is removed.

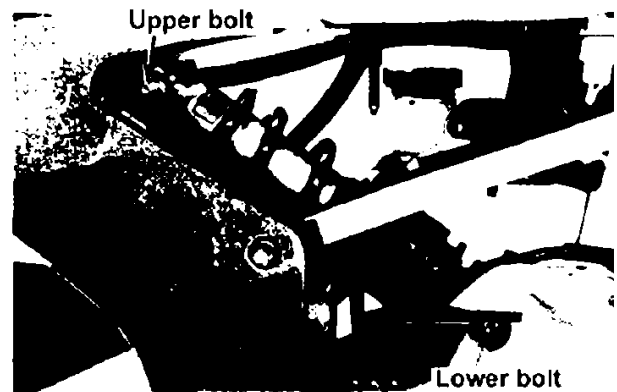

## Disassembly

### General Caution

#### Caution

- The damper unit contains compressed Nitrogen gas. Strictly follow the instructions below:
  - Do not heat or disassemble the unit.
  - When disposing of the damper unit, bleed Nitrogen gas from the unit. Refer to (24-13).

Pre-set the adjuster to the softest position prior to removing the rear cushion assembly.

Install the rear cushion compressor.

#### Common tool:

Rear cushion compressor  
07GME-0010000

#### Special tool:

Rear cushion compressor attachment  
07959-MB10000

Compress the spring and remove the stopper ring.

Do not disassemble while the lock nut on the lower joint is loose.

Remove the tool and remove the spring seat and the spring.

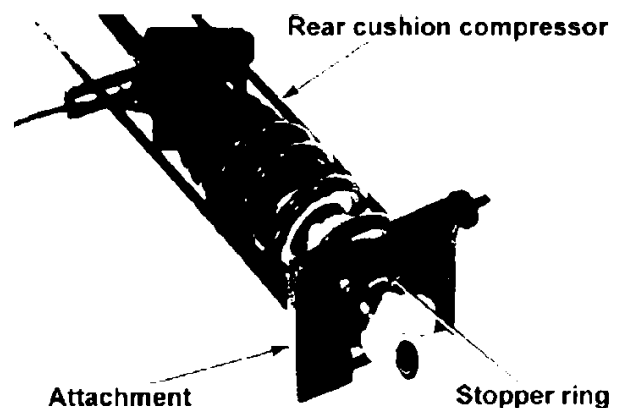
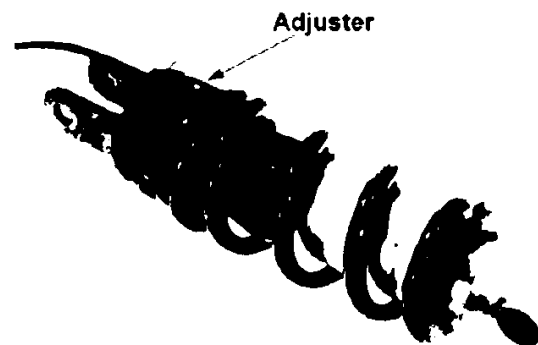

# CBR250RR(L)

Inspect the damper seal for oil leak.  
Inspect the damper rubber for wear / damage.

Do not disassemble while the lock nut on the lower joint is loose.

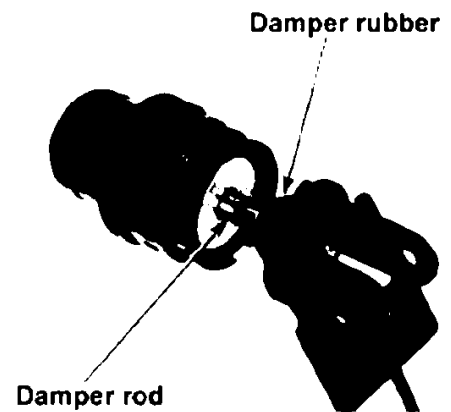

## Assembly

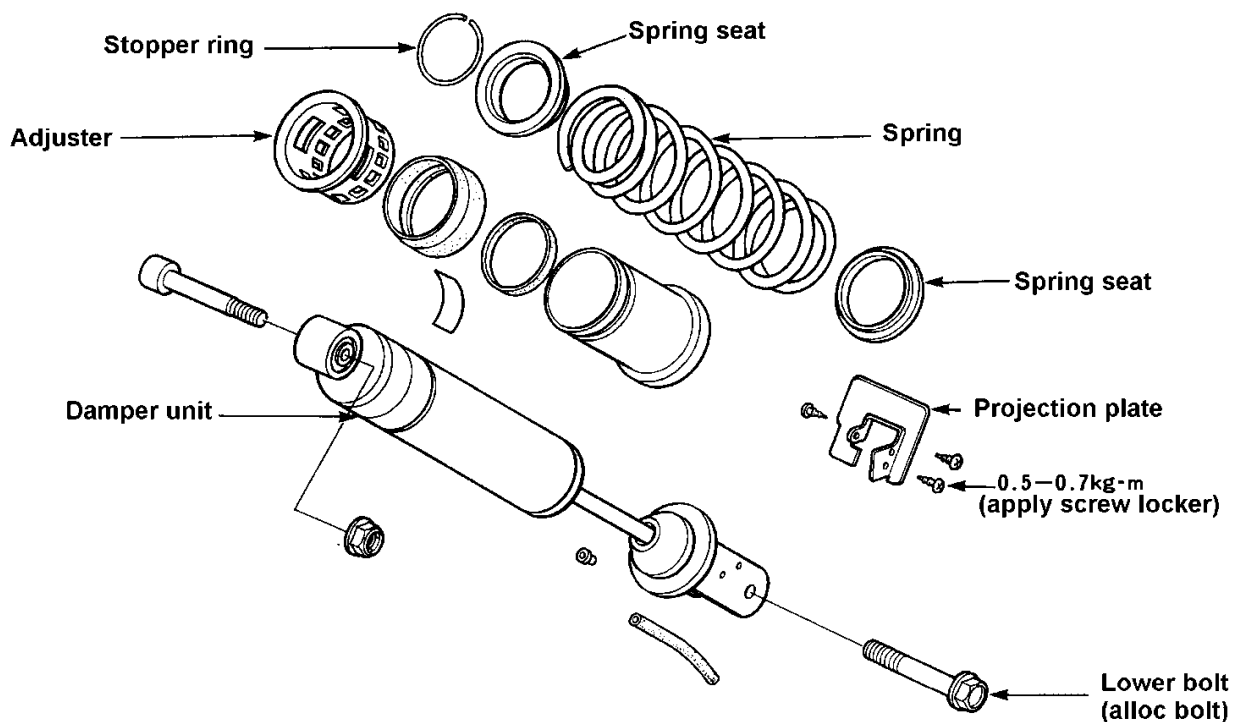

Install the spring and the spring seat to the damper.  
Compress the spring by using the rear cushion compressor until the stopper ring can be installed.

### Common tool:

Rear cushion compressor  
07GME-0010000

### Special tool:

Rear cushion compressor attachment  
07959-MB10000

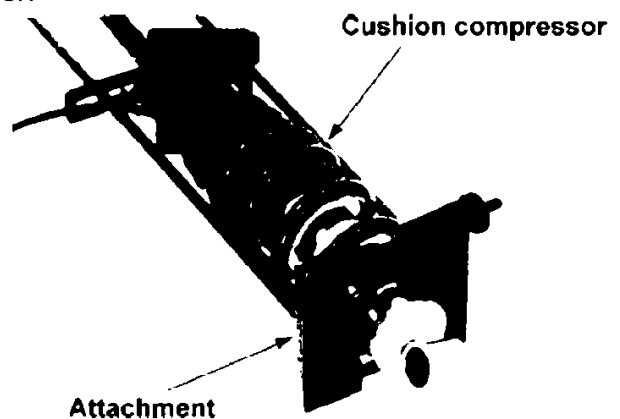



# CBR250RR(L)

Install the stopper ring.  
Remove the rear cushion compressor from the rear cushion.

## Rear cushion installation

Install the rear cushion.  
Install an upper bolt and a nut.

**Torque: 4.5 – 5.5kg-m**

Install the new rear cushion lower bolt.

**Torque: 4.5 – 5.5kg-m**

- Refer to (24-8) to route the rear drain tube.
- Replace the rear cushion lower bolt with a new one when removed.

Install the fuel tank (24-21).

## Suspension Linkage removal

Support the frame to lift the rear wheel.  
Remove the left step holder (24-45).  
Unscrew the connecting rod bolt (frame side).  
Unscrew the rear cushion lower bolt and the cushion arm bolt.  
Remove the suspension linkage in assy.

## Disassembly

Unscrew the connecting rod bolt (cushion arm side) to separate the arm and the rod.

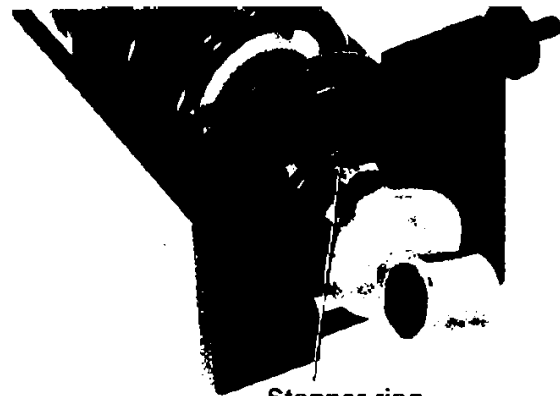

Stopper ring

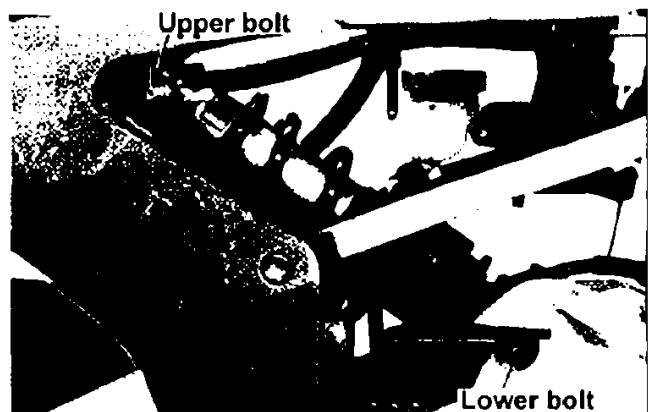

Upper bolt

Lower bolt

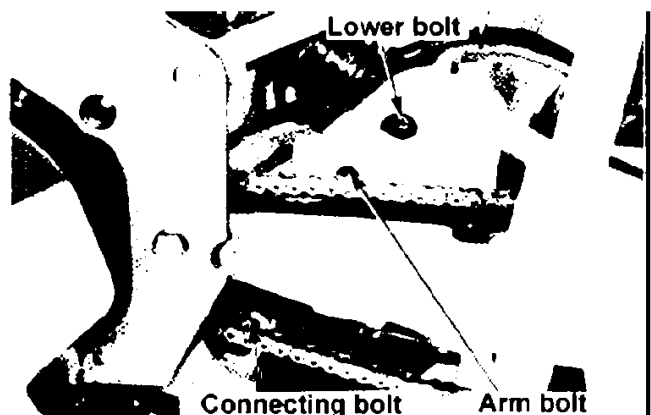

Lower bolt

Connecting bolt

Arm bolt

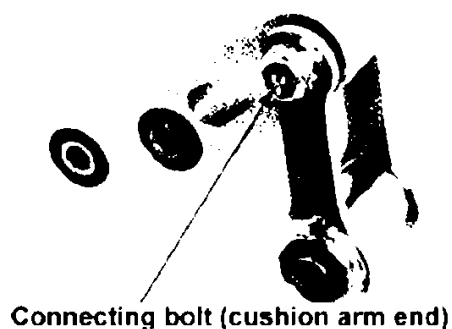

Connecting bolt (cushion arm end)

# CBR250RR(L)

## Needle bearing replacement

Remove the dust seal and the collar from the cushion connecting rod.  
Replace the needle bearing by using a press machine.

### Special tool:

Bush driver Assy 07GMD-KT80100

- Press the labeled side of the needle bearing in.
- Press in the needle bearing for 7.5mm from the connecting rod end.

Remove the dust seal and the collar from the cushion arm.

### Special tool:

Bush driver Assy  
07GMD-KT80100

- Press the labeled side of the needle bearing in.
- Press in the needle bearing for 5.5mm from the cushion arm end.

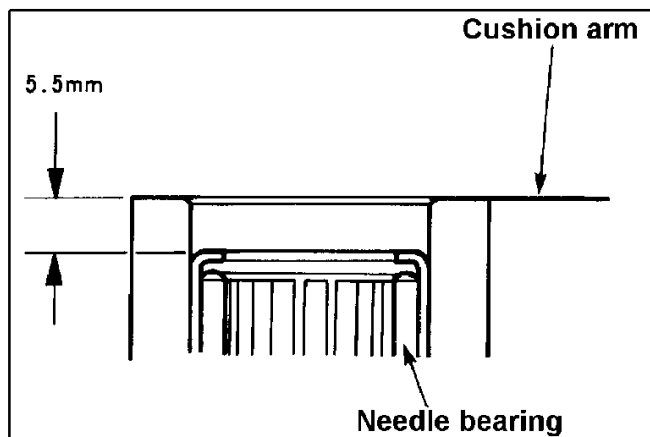
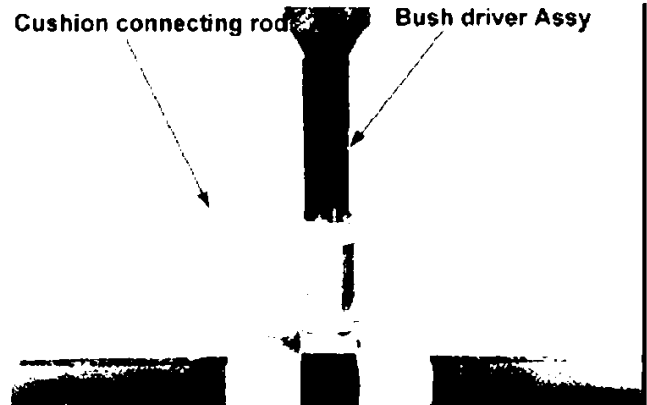
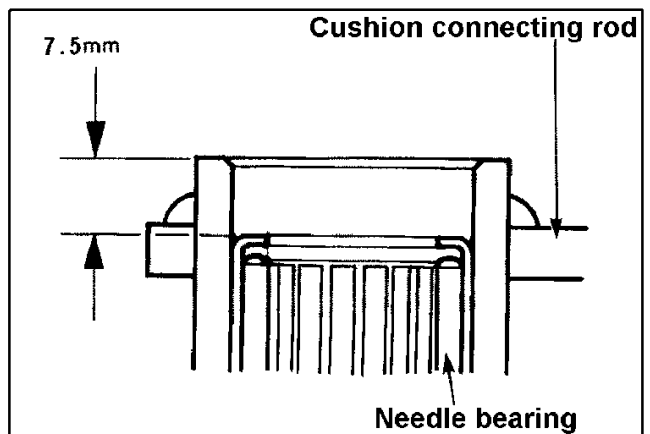
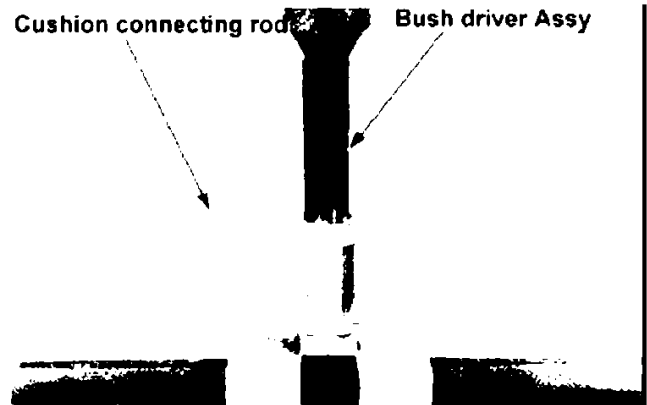

# CBR250RR(L)

## Assembly

Screw the cushion arm connecting rod bolt and assemble the arm and the connecting rod.

**Torque: 4.5 – 5.5kg-m**

## Suspension Linkage Installation

Set the linkage to its mounting position.

Set the cushion arm mark (KA8↑ UP) upwards when installing.

Install the new rear cushion lower bolt and the cushion arm bolt (24-52).

**Torque: 4.5 – 5.5kg-m**

Install the connecting rod bolt and the nut (frame side).

**Torque: 4.5 – 5.5kg-m**

Install the left step holder (24-45).

## Rear fork removal

Support the frame to lift the rear wheel.

Remove the rear wheel (21-24).

Remove the lower fairings (24-58).

Remove the drive sprocket (24-42).

Remove the rear cushion (24-50).

Remove the suspension linkage (24-52).

Remove the rear hose clamp from the rear fork.

Unscrew the rear fork pivot bolt/nut to remove the rear fork (14-18).

## Pivot bearing replacement

Remove the right pivot collar and the dust seal (14-19).

Remove the left pivot collar and the dust seal (14-19).

Remove the distance collar from the rear fork pivot (14-19).

Remove the circlip.

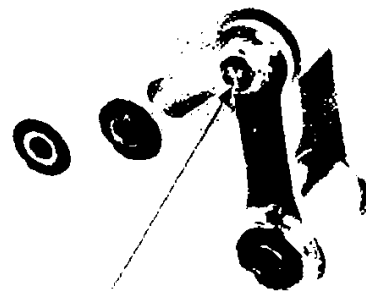

Cushion arm connecting bolt

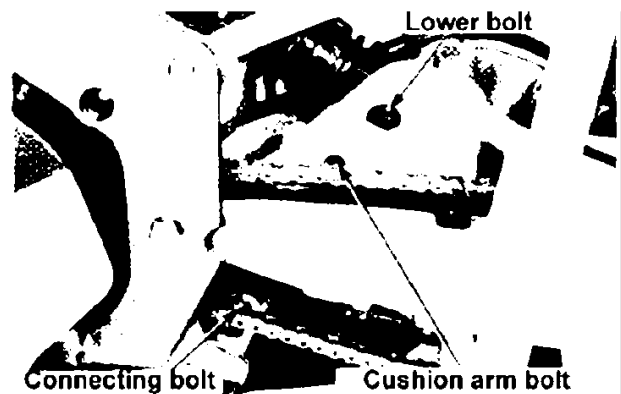

Connecting bolt

Cushion arm bolt

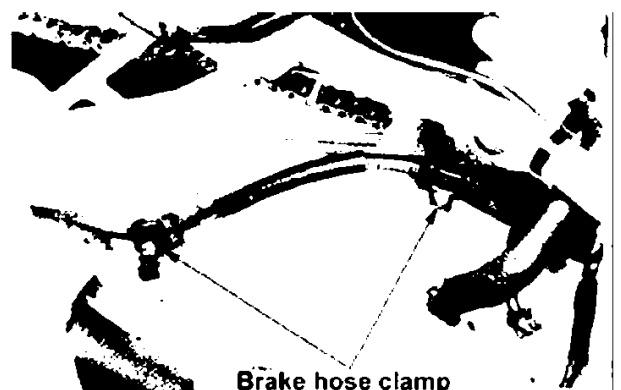

Brake hose clamp

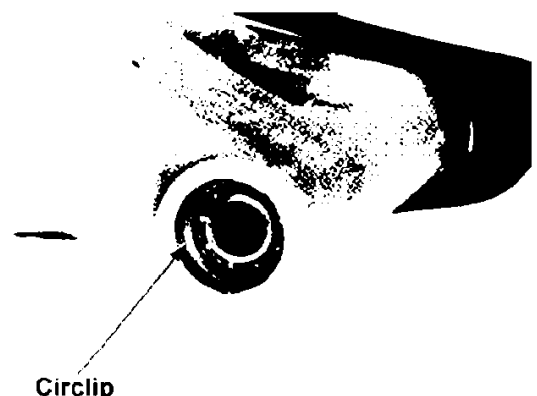

Circlip

# CBR250RR(L)

Remove the right pivot bearing (ballbearing).

Special tools:

- Bearing remover set 15mm  
07936-KC10000
- Remover handle 15mm  
07936-KC10100
- Remover 15mm  
07936-KC10200
- Sliding weight  
07741-0010201

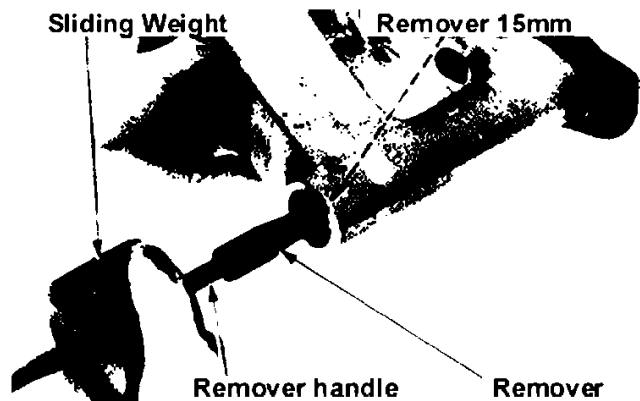

Remove the left pivot bearing.

Special tools:

- Bearing remover attachment  
07LMC-KV30200
- Driver shaft  
07946-MJ00100

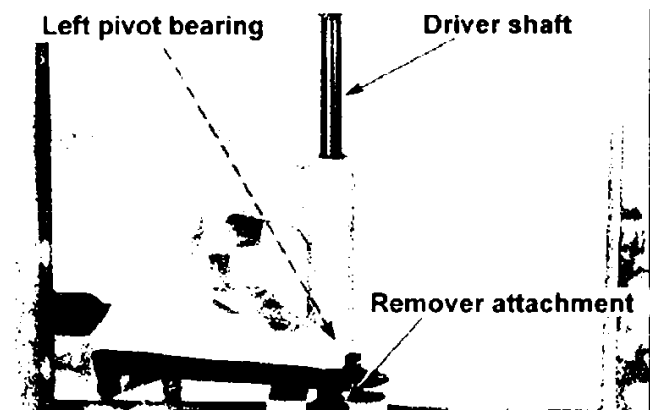

By using a press machine, press in the left pivot bearing to 5.5mm depth from the rear fork end.

Common tools:

- Driver handle A  
07749-0010000
- Outer driver (32 x 35mm)  
07746-0010100

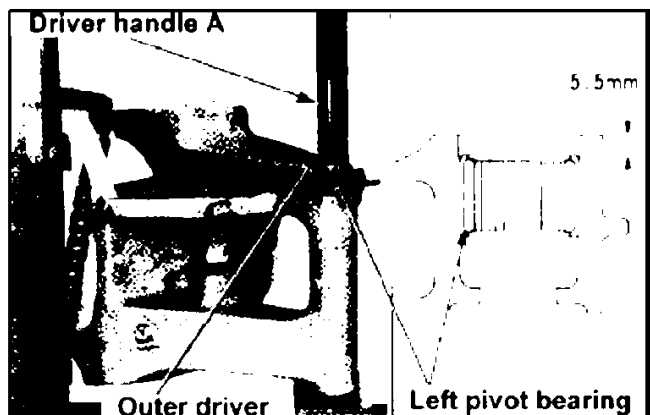

Press in the right pivot bearing.

Common tools:

- Driver handle A  
07749-0010000
- Outer driver (32 x 35mm)  
07746-0010100

Press in the right pivot bearing until the stopper.

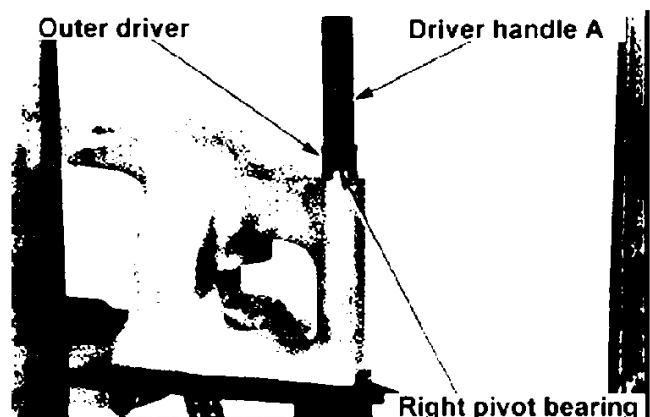

- Install the circlip to the slit.
- Install the distance collar to the rear fork pivot.
- Install the dust seal and the right pivot collar (21-30).
- Install the dust seal and the left pivot collar (21-29).

# CBR250RR(L)

## Rear fork installation

Install rear fork.  
Clamp the rear brake hose to the rear fork.  
Screw the pivot bolt, the lock nut and the pivot nut (14-22).  
Install the rear cushion (24-52).  
Install suspension linkage (24-54).  
Install the rear wheel (21-24).  
Install the drive sprocket (24-43).  
Install the drive sprocket cover (6-3).  
Install the lower fairings (24-58).

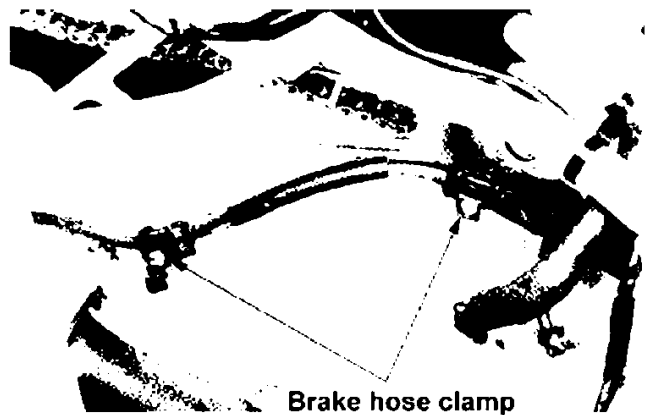

## Braking System

### Brake Pedal removal

Unscrew rear master cylinder mount bolts to remove the right step guard.  
Unscrew the right step holder bolt.

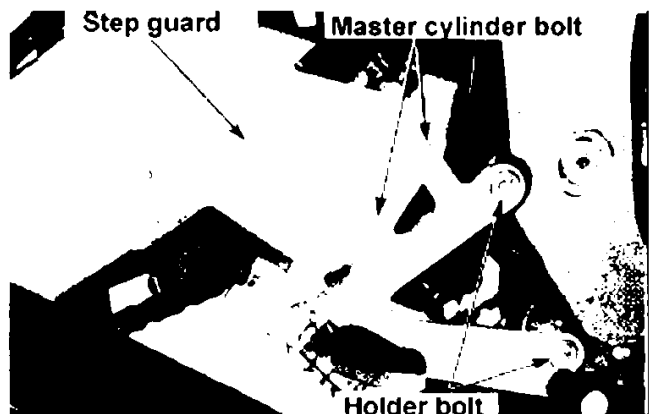

Remove the cotter pin and the joint pin to detach the master cylinder from the brake pedal.  
Remove the brake switch spring to remove the brake switch.  
Remove the return spring.

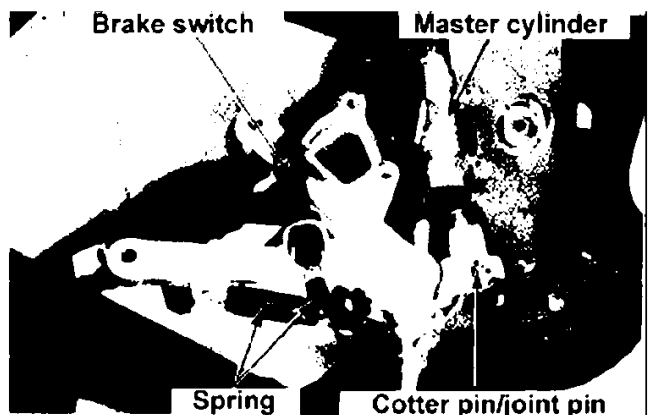

Unscrew the stop pivot bolt to remove the brake pedal, the step and the wave washer.

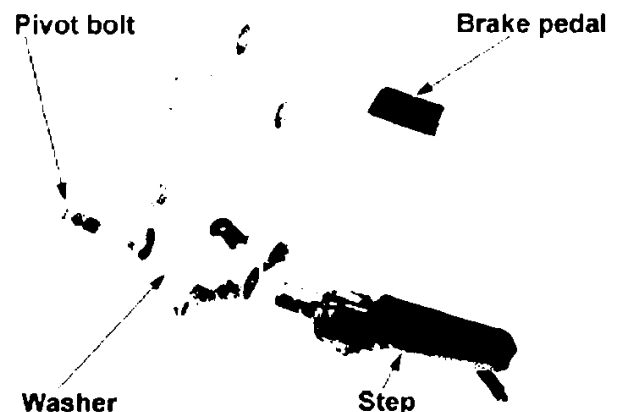

# CBR250RR(L)

## Installation

Replace the step pivot bolt whenever it is removed and clean the female thread.

Apply grease to the interior surface of the brake pedal bush.

Install the brake pedal and the wave washer to the step.

Set the slit on the step pivot to the slit on the step holder and screw the new step pivot bolt.

**Torque: 3.5 – 4.5kg-m**

Install the brake pedal and the master cylinder push rod with the joint pin.

Then install new cotter pin.

Install the brake switch and the brake switch spring.

Set the return spring.

Install the rear master cylinder and the right step guard and temporarily screw the rear master cylinder mount bolts.

Install the right step holder and screw the holder bolts.

**Torque: 2.4 – 3.0kg-m**

Screw the rear master cylinder mount bolts.

**Torque: 1.0 – 1.4kg-m**

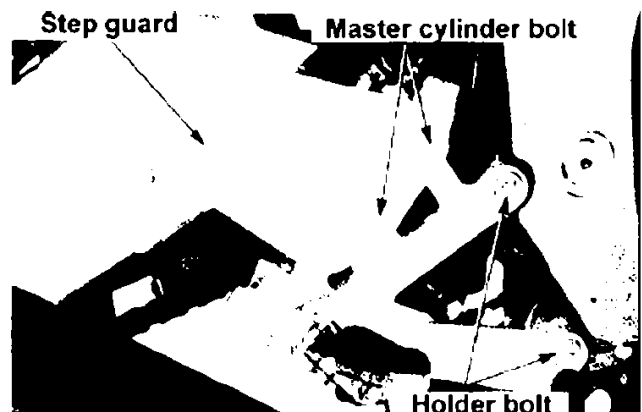
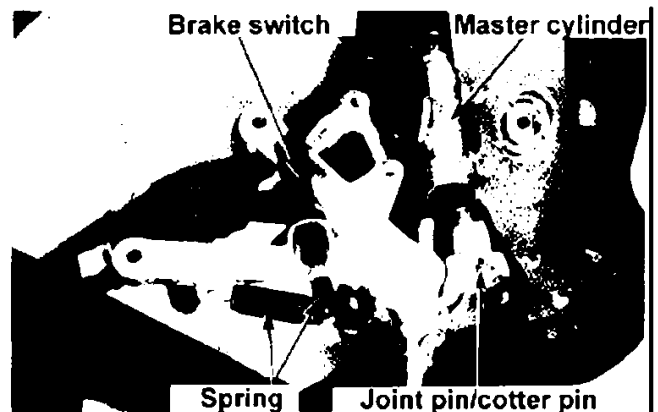
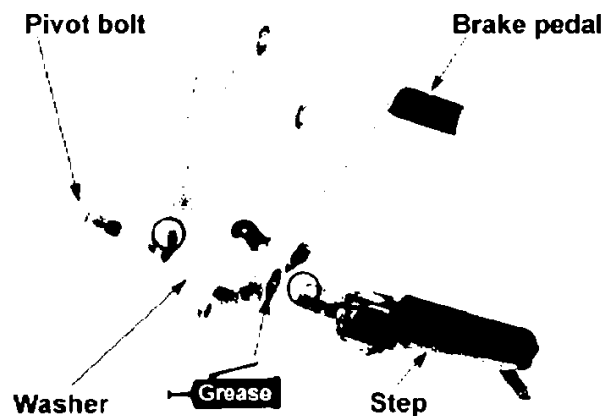

# CBR250RR(L)

---

## Fairing & Exhaust Pipe

Refer to (22-30) for removal / installation.

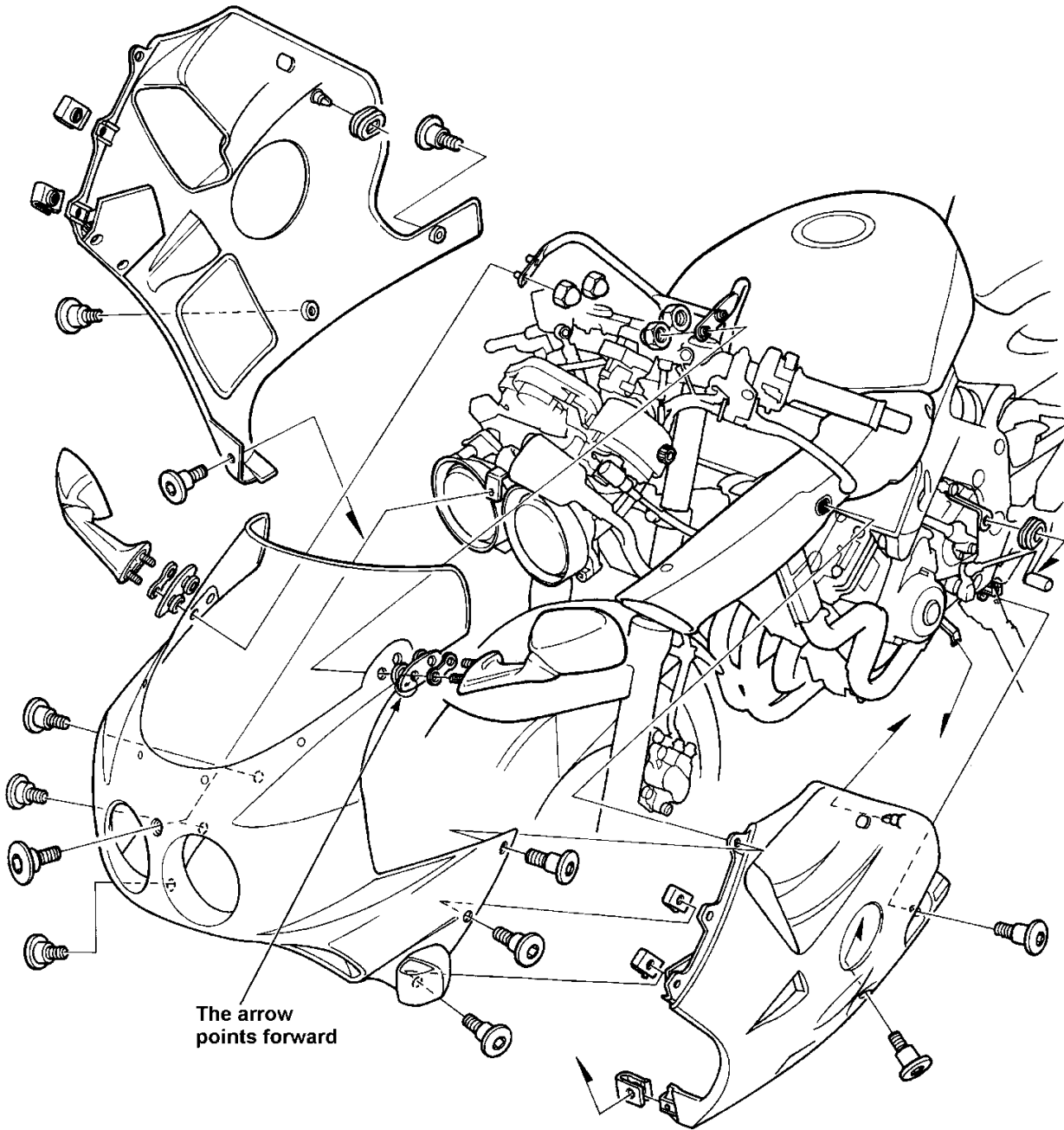

# CBR250RR(L)

Refer to (22-30) for removal / installation.

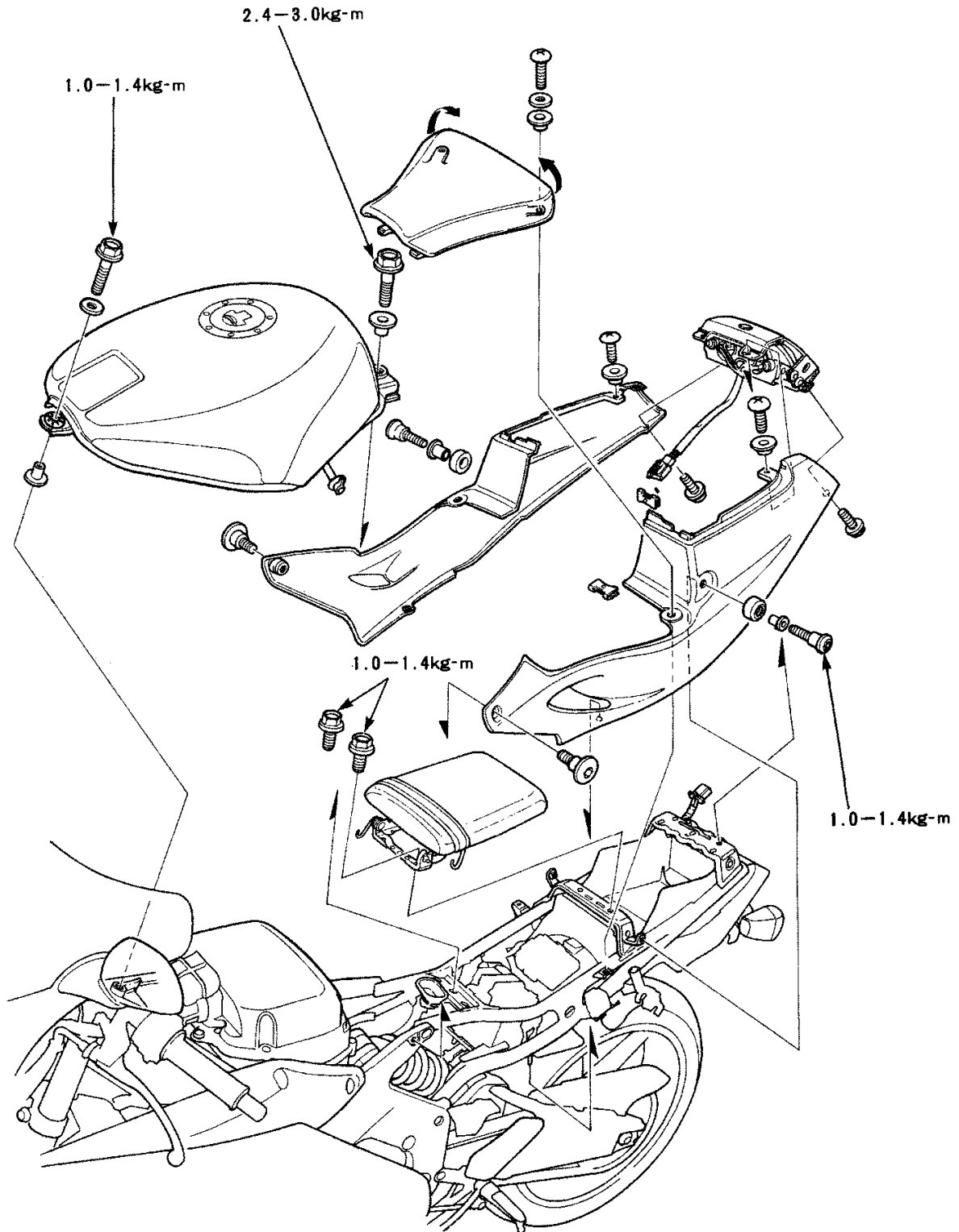



# CBR250RR(L)

## Exhaust Pipe removal

### Caution

Remove while the muffler and the pipe are cool.

Remove lower cowls (24-59).  
Unscrew exhaust pipe joint nuts.  
Unscrew muffler mount bolt/nut.  
Unscrew exhaust pipe mount bolt/nut to remove the exhaust pipe and the gasket.

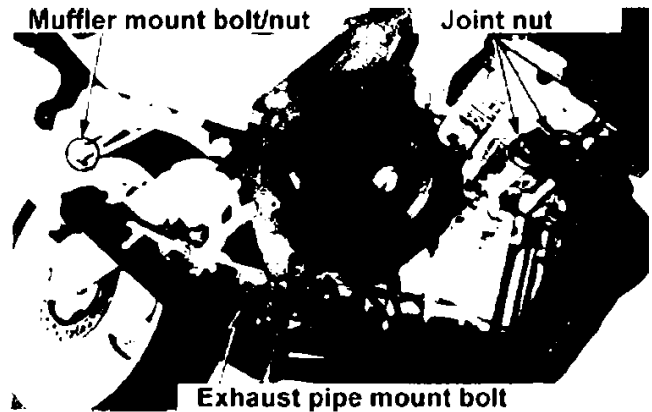

## Exhaust Pipe installation

Follow the removal procedure in reverse order.

Torque:

Exhaust Pipe joint nut	1.0 – 1.4kg-m
Muffler mount bolt	2.4 – 3.0kg-m
Exhaust pipe mount bolt	2.4 – 3.0kg-m

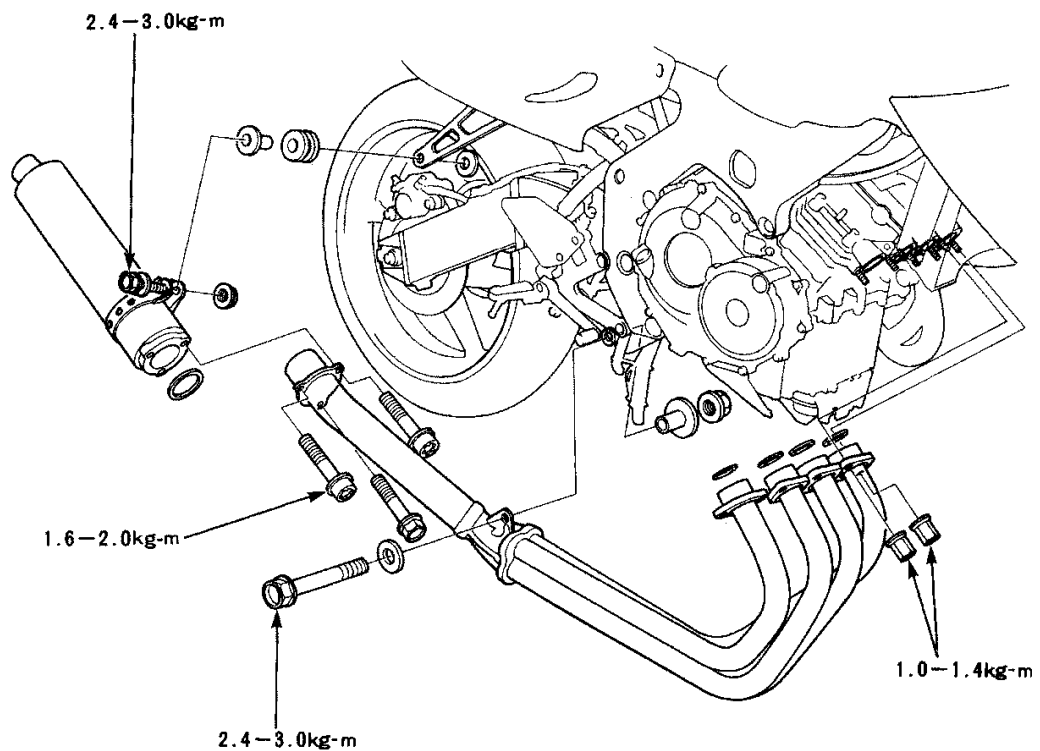

# CBR250RR(L)

## Muffler removal

Caution

Remove while the muffler and the pipe are cool.

Unscrew muffler joint bolts.

Common tools:

Torx bit (T30)      07703-0010200

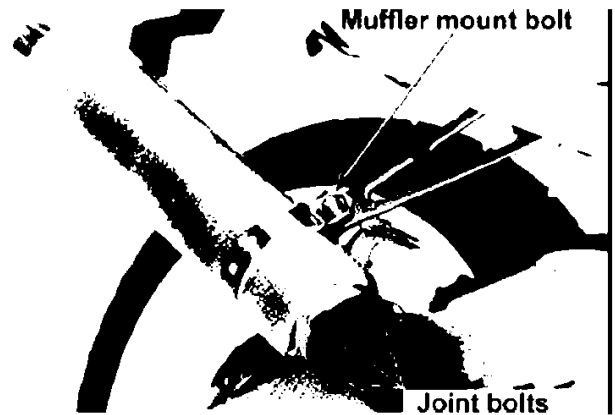

Unscrew the muffler mount bolt/nut to remove the muffler and gasket.

## Muffler installation

Install the new gasket.

Follow the removal procedure in reverse order.

Torque:

Muffler joint bolt:      1.6 – 2.0kg-m

Muffler mount bolt      2.4 – 3.0kg-m



## Battery & Charging System

### Regulator / rectifier inspection

- Do not touch the probes while measuring.
- Use one of the following multi meters. Other products may indicate different resistance values.
  - KOWA 07411-0020000 digital multi meter
  - SANWA 07308-0020001 analogue multi meter
  - KOWA TH – 5H
- Set the range as follows:
  - SANWA      k Ω range
  - KOWA      Rx100Ω range (CDI Ω, Rx100 for digital multi meter)
- Multi meters may have false indication when their batteries are low. Check the battery first if the measured value is faulty.
- Multiply by 100 to the indicated value to obtain measured value in KOWA products.

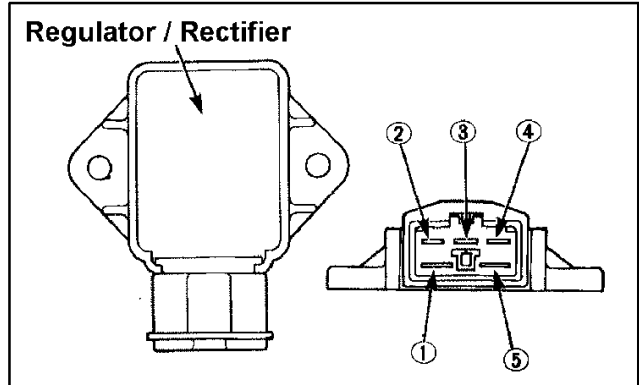

Unit: kΩ

⊖	+	①	②	③	④	⑤
①		∞	∞	∞	∞	∞
②		0.5-10	∞	∞	∞	∞
③		0.5-10	∞	∞	∞	∞
④		0.5-10	∞	∞	∞	∞
⑤		0.7-15	0.5-10	0.5-10	0.5-10	∞

# CBR250RR(L)

## Ignition System

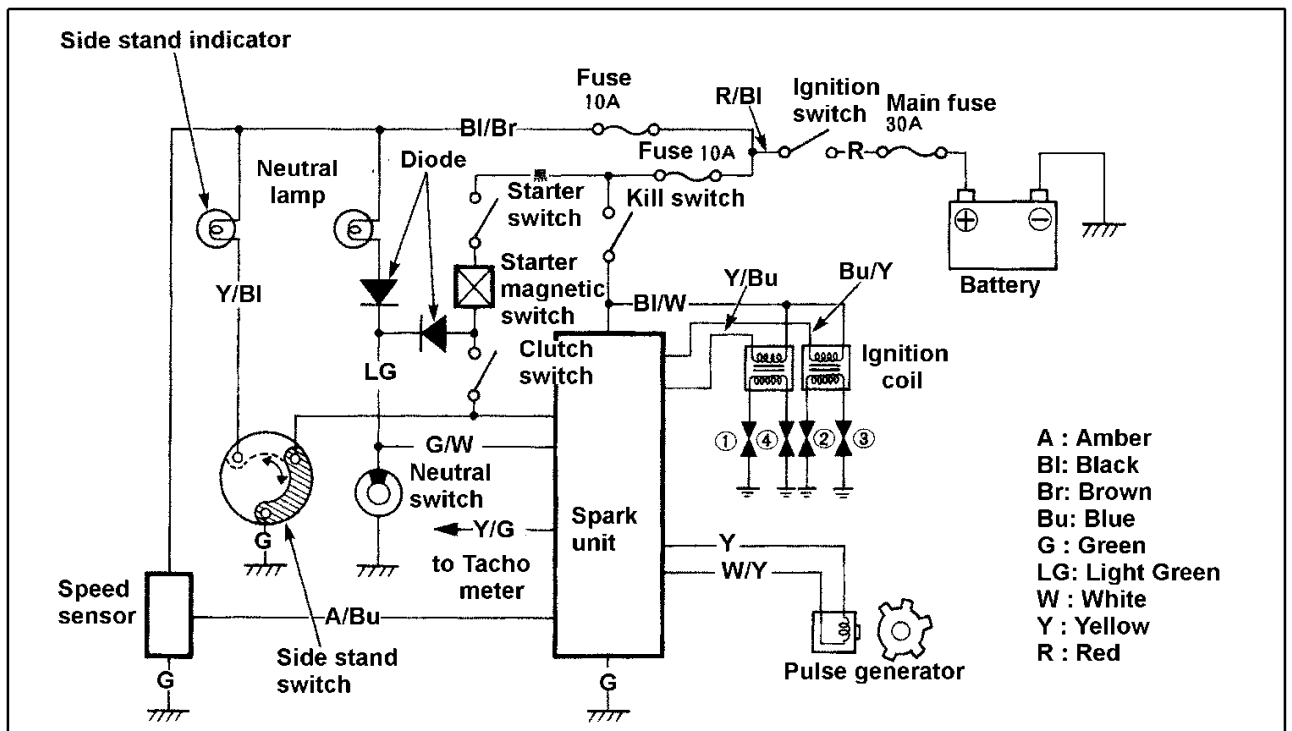
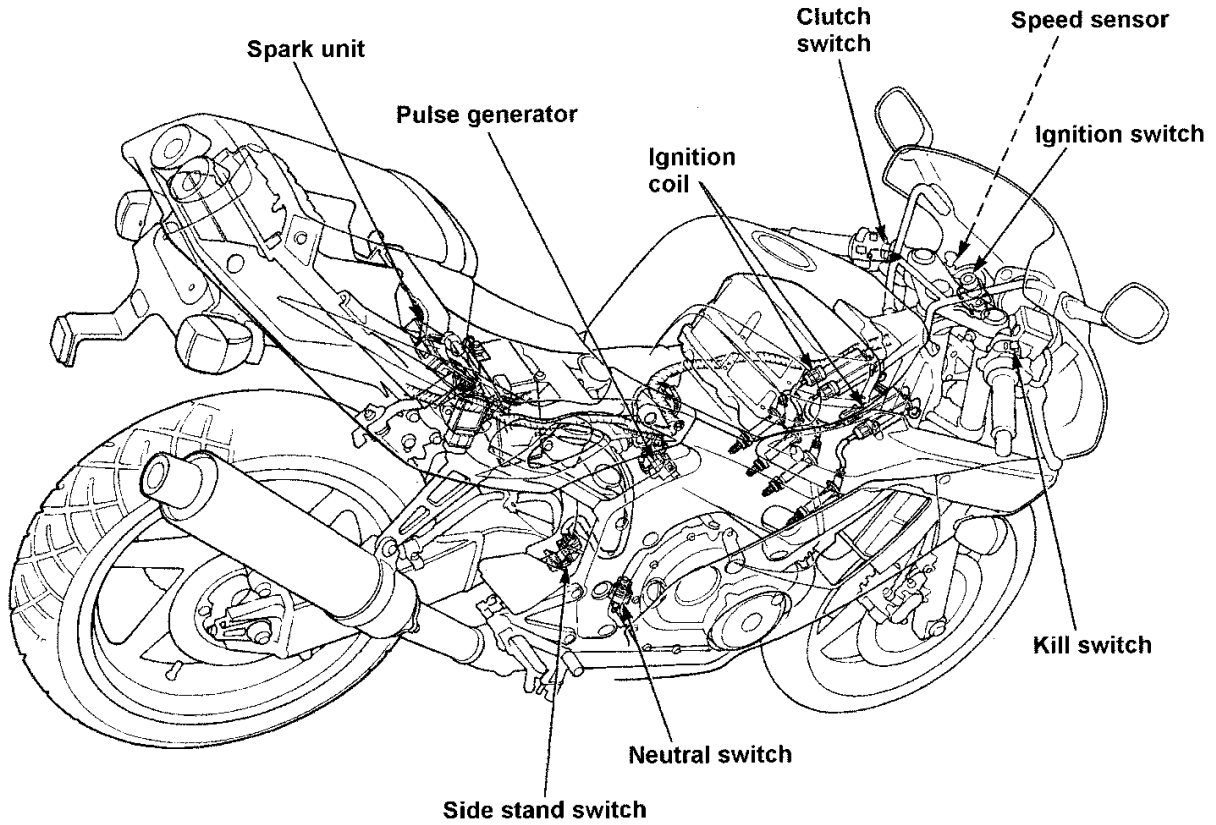

# CBR250RR(L)

## General Information

- Follow the troubleshooting chart (24-15) for the ignition system check.
- The ignition timing cannot be adjusted as the electrical advancing system is internally mounted in the unit.
- The ignition system unit is fragile. Handle with care. Whenever connecting / disconnecting the connectors or couplers, turn the ignition switch OFF beforehand.
- The majority of causes of the ignition trouble are connection problems. Inspect all connection.
- Use reasonably well charged battery. Low charged battery might not produce sufficient cranking and spark voltage.
- Use proper spark plugs. Improper spark plugs may cause engine trouble/damage.
- This section describes peak voltage inspection. Although the coil resistance inspection is also mentioned, it may not give correct idea.
- Refer to (20-9) for the neutral switch inspection and the locations of the switches / couplers.
- Refer to (20-6) for the ignition / kill switch inspection.
- This model is equipped with an ignition cut off style side stand. The system allows the ignition to activate when the gear is in neutral or the side stand is extended, or both.

## Ignition system inspection

- If there is no spark, check all wiring connections and then measure the peak voltage.
- Use genuine multi meter or a model which has an impedance of 10M $\Omega$  / DCV or above.

Connect the peak voltage adapter to the multi meter.

### Measuring tools:

Peak voltage adapter                      07HGJ-0020100  
Genuine KOWA multi meter              07411-0020000  
Or multi meter of 10M $\Omega$ /DCV or above impedance.

### Ignition Coil primary voltage

- Check all wiring connections before measuring
- Measure the peak voltage while having cylinder compression and plugs/caps properly installed. If the plug caps were removed, the peak voltage may be over read.

If the engine ignites with normal spark, the cranking speed becomes unstable.  
In the same manner as a normal spark test, leave the spark plug in the cylinder head and set new (good) spark plugs to each plug caps and earth to the engine.

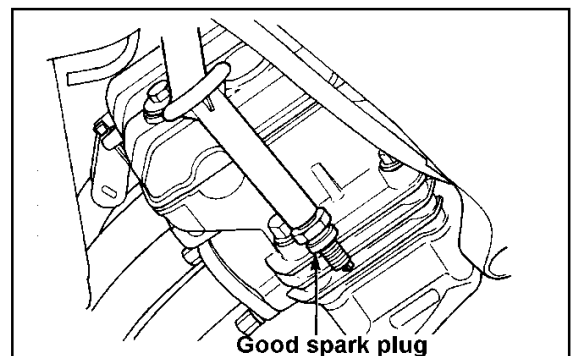
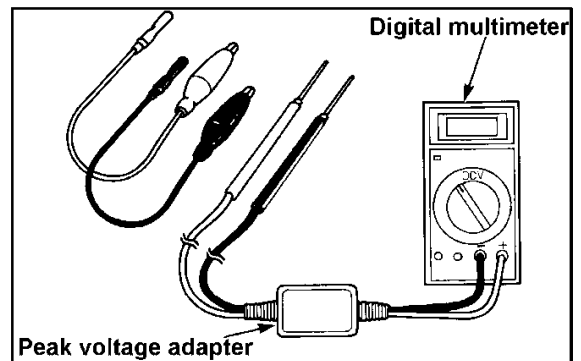

# CBR250RR(L)

Remove the fuel tank (24-21).

Leave the leads connected to the ignition coil and connect the peak voltage adapter between the primary voltage terminal and the body earth.

## Connection:

**#1 and #4 ignition coils**

**Yellow/Blue (+) – body earth (-)**

**#2 and #3 ignition coils**

**Blue/Yellow (+) – body earth (-)**

Turn the ignition switch ON and the kill switch RUN. Monitor the initial voltage at this moment. It should be close to the battery voltage.

If there is no voltage, the ignition power circuit is faulty.

Refer to the troubleshooting to inspect the circuit before measuring the peak voltage.

Turn the ignition switch ON and the kill switch RUN.

Crank the engine with the starter motor and measure each peak voltage.

**Peak Voltage:** 128 volts or above

**CAUTION: Do not touch the probe while measuring.**

The measured peak voltages can be different between each ignition coil, as long as the values are at or above the standard.

If the measured peak voltages are out of the range, connect the adapter to the ignition coil 3P-coupler terminal.

Re-measure the peak voltage and compare the result with the original value.

**CAUTION: Do not touch the probe while measuring.**

The measured peak voltages can be different between each ignition coil, as long as the values are at or above the standard.

## Pulse Generator peak voltage

- Check the wiring connection.
- Measure the peak voltage with cylinder compression and plugs/caps properly installed. If the plug caps were removed, the peak voltage may be over read.

Remove the seat.

Disconnect a coupler on the spark unit.

Connect the peak voltage adapter probe to the following terminals on the harness end:

**Connection:** White / Yellow (-) – Yellow (+)

Turn the ignition on, the kill switch RUN.

Crank the engine and measure the peak voltage.

**Peak Voltage:** 0.91 volts or more

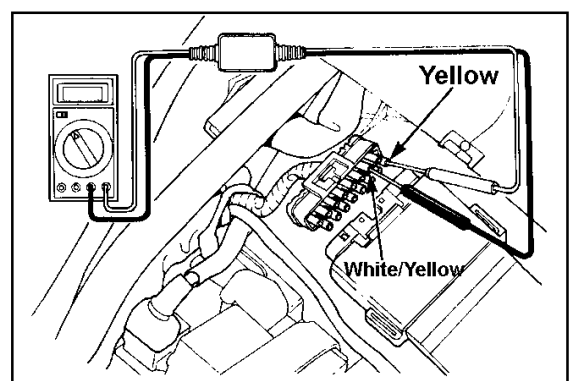
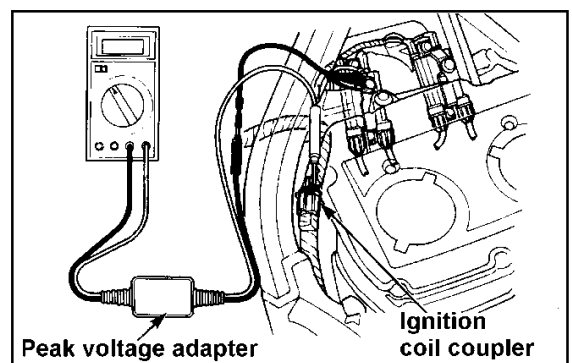
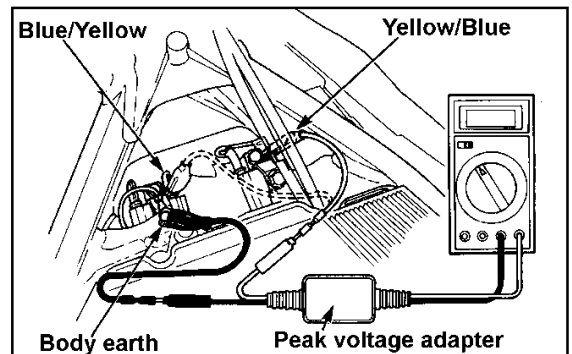

# CBR250RR(L)

**CAUTION:** Do not touch the probe while measuring.

If the peak voltages at the spark unit coupler are faulty, disconnect the pulse generator 2P (White) coupler and re-measure the peak voltage between the above terminals.

Peak voltage: 0.91 volts or above

- If the values at the unit end are faulty and the ones at the pulse generator coupler are fine, check coupler connections and wire harness.
- If both values are faulty, follow the troubleshooting chart to check each item and judge the pulse generator is faulty.

## Side Stand Switch

### Operation

Move the side stand to check its operation. Set the transmission neutral and start the engine with the side stand retracted. Hold the clutch lever and select any gear position. The engine should stop by extending the side stand. If the engine does not stop, inspect the side stand switch (24-65).

Inspect the side stand switch attachment.

### Torque:

Side stand pivot bolt	0.5 – 1.0kg-m
Side stand pivot nut	3.5 – 4.5kg-m
Side stand switch mount bolt	0.8 – 1.2kg-m

### Inspection

Turn the ignition "OFF". Remove the spark unit from the rear fender and disconnect its coupler. Inspect continuity between the Green/White and Green terminals on the harness end coupler. The continuity should only exist when the side stand is retracted. If the result is fault, inspect the wire harness and the side stand switch unit.

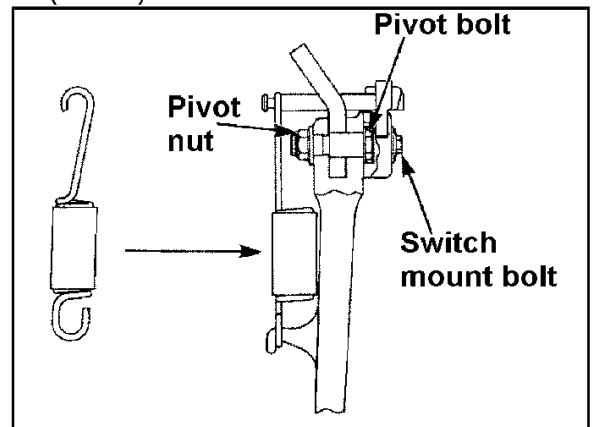
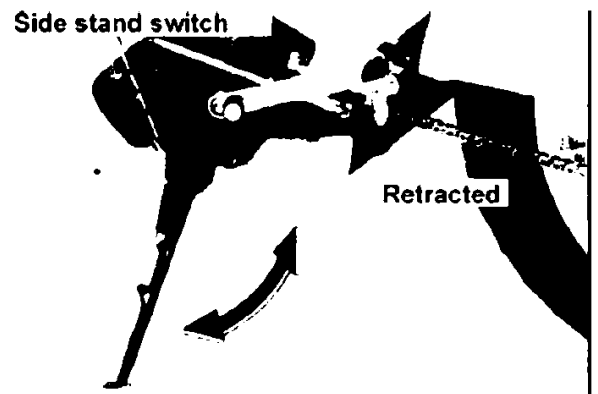
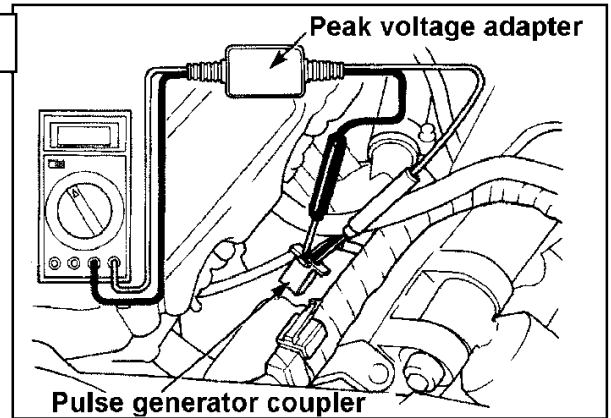

# CBR250RR(L)

## Side stand switch unit inspection

Disconnect the side stand switch 3P coupler and inspect its continuity by following the table below. Continuity should exist between  $\bigcirc$   $\ominus$ .

Lead colour	Green /White	Green	Yellow /Black
Side stand extended		$\bigcirc$ — $\bigcirc$	$\bigcirc$ — $\bigcirc$
Side stand retracted	$\bigcirc$ — $\bigcirc$	$\bigcirc$ — $\bigcirc$	

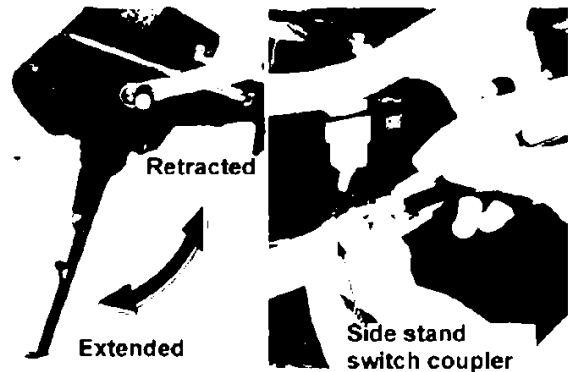

## Side stand switch removal

Turn the ignition switch "OFF".  
Disconnect the side stand switch 3P coupler.  
Unscrew the side stand switch mount bolt to remove the switch.

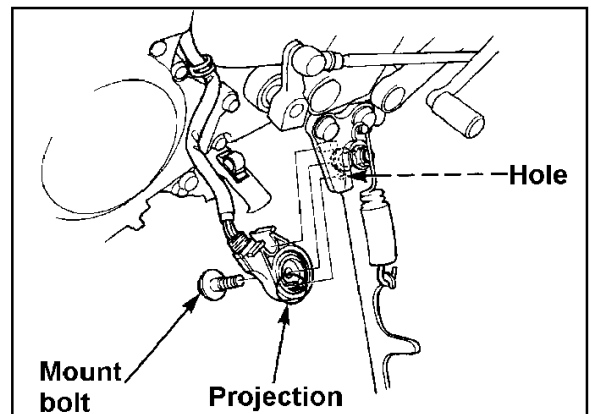

## Side stand switch installation

Set the projection on the switch to the hole on the side stand to install the switch.  
Screw the switch mount bolt.  
Connect the 3P coupler.

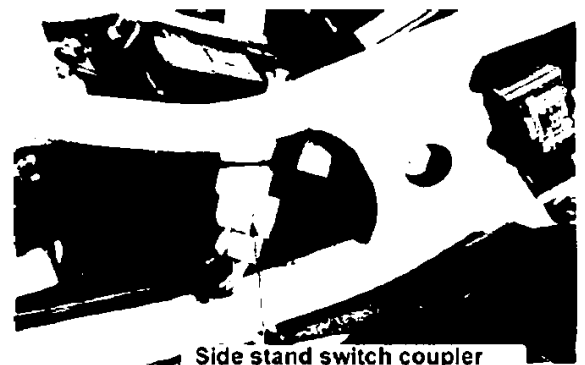

## Lamps, Instruments and switches

### Headlamp relay

Unable to turn the headlamp "off"

Inspect the lighting switch and the dimmer switch (24-67).

If the lighting switch is fine, inspect the headlamp relay (refer to the next page).

If the relay is fine, inspect the wire harness for short circuit.



# CBR250RR(L)

## Headlamp and Switches

Inspect the headlamp bulb and the sub fuse (headlamp 15A).

Disconnect the headlamp relay coupler.

Conduct the following inspection:

- Check the wiring connection
- Inspection continuity between the green terminal on the coupler and the body earth. If there is no continuity, repair or replace the wire harness. If there is continuity, turn the ignition ON and measure the voltage between black/red terminal and the body earth. It should have battery voltage.

If there is no voltage, the black/red lead between the headlamp relay and the fuse box has open circuit.

If the battery voltage exists, inspect the headlamp relay.

If the relay unit is fine, the leads between the headlamp relay and the headlamp coupler, or, between the headlamp relay and the lighting switch, have open circuit. Replace the wire harness.

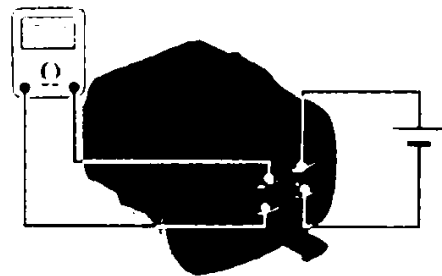
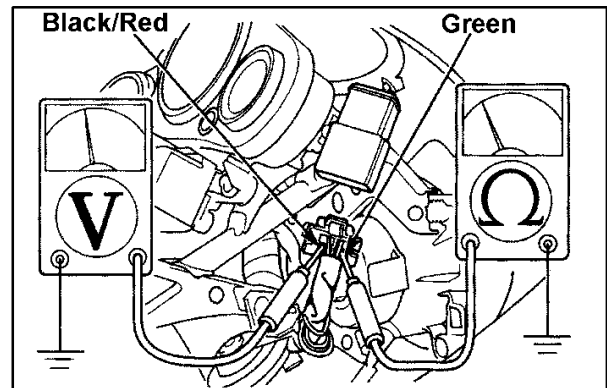

## Headlamp Relay Inspection

Remove the relay unit.

Connect the battery between the Blue/Yellow and Green terminals (equivalent).

Continuity should exist between Black/Red and Blue terminals (equivalent).

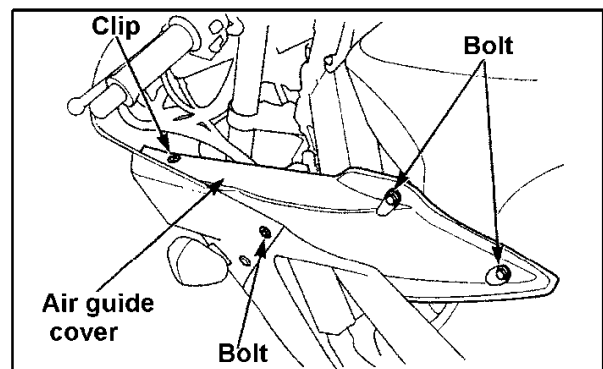

## Sub Fuses replacement

Unscrew two left air guide mount bolts.

Unscrew the lower cowl mount bolt.

Remove the trim clip.

Remove the left air guide cover to replace sub fuses.

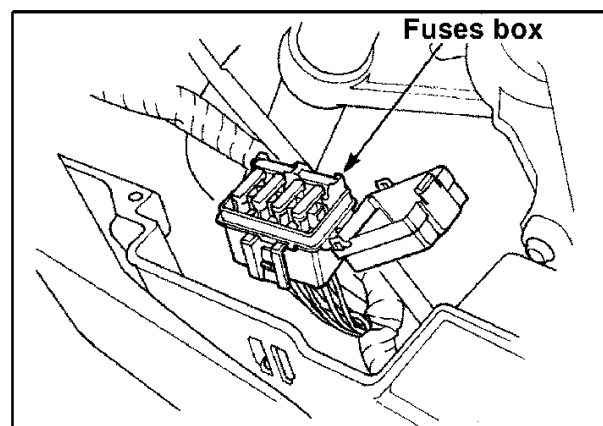



# CBR250RR(L)

## Instruments removal / installation

Unscrew two instruments mount bolts.

The upper fairing may be left attached to remove/install instruments.

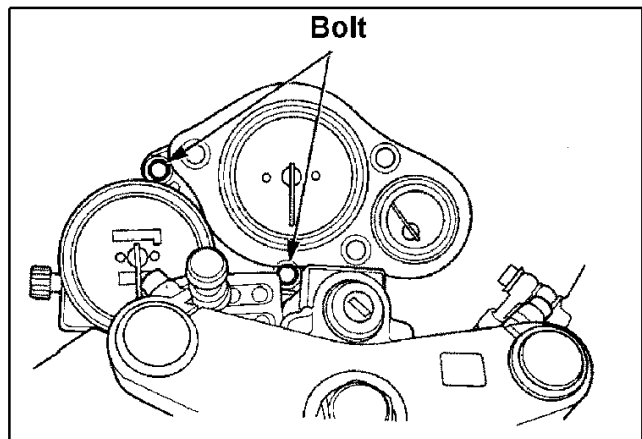

Disconnect the speedometer cable (22-34).  
Lift up the instruments Assy to disconnect the wire coupler.  
Remove the instruments Assy.

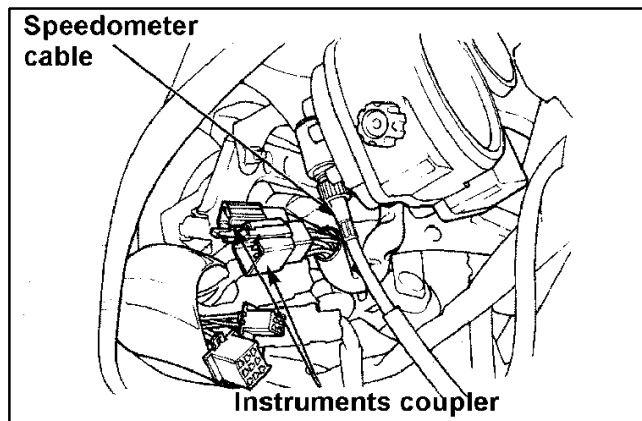

## Instruments disassembly

Remove the trip meter reset knob.  
Unscrew to remove the upper cover.  
Disconnect all connectors, bulb sockets and unscrew individual instruments mount screws to disassemble the instruments.

Record the colour of leads if the screw is holding the lead before unscrewing.

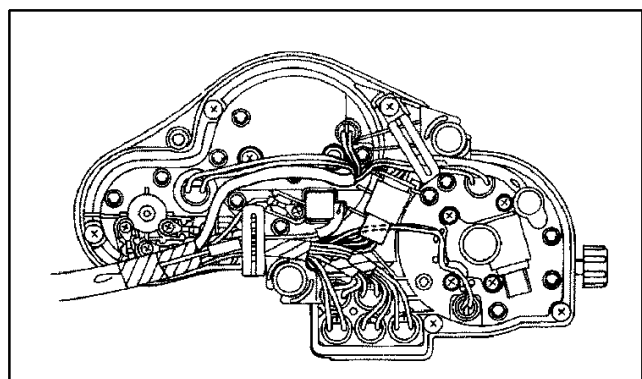

# CBR250RR(L)

---

## Instruments Assembly / Installation

Follow the disassembly / removal procedure in reverse order.

- Correctly route wire harnesses.
- Install the instruments firmly to the grommets.

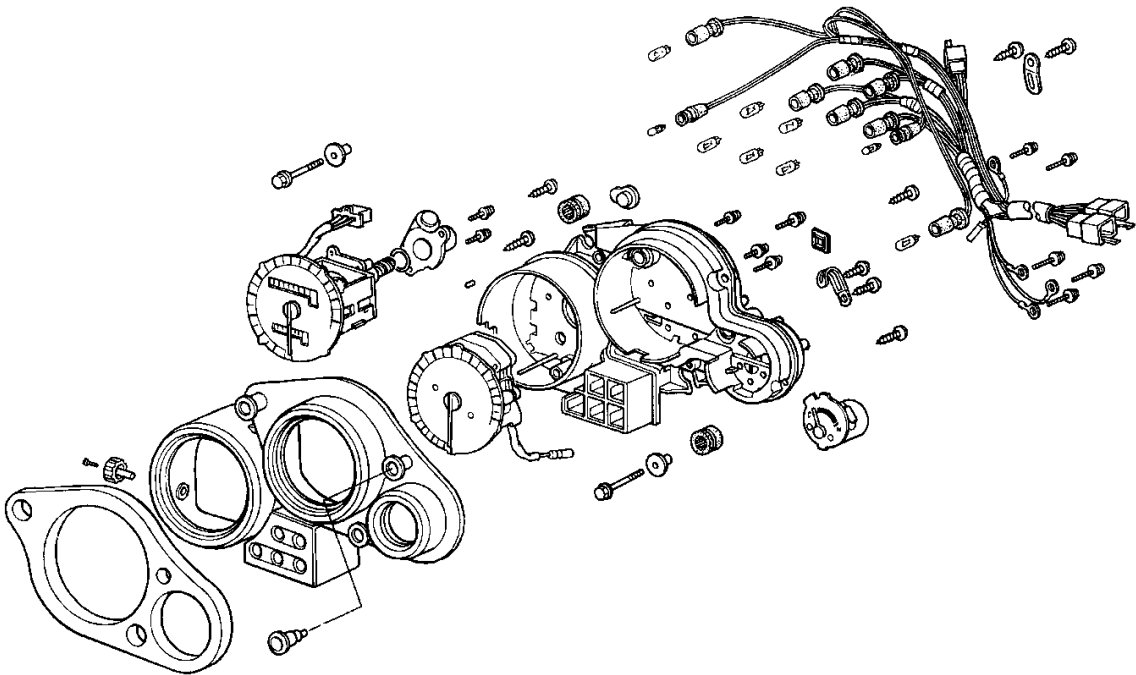

**CBR250R (R)****Table of Contents**

<b>Specification .....</b>	<b>25 – 2</b>
<b>Torque Settings .....</b>	<b>25 – 3</b>
<b>Lubrication and Sealant.....</b>	<b>25 – 6</b>
<b>Special and Common Tools .....</b>	<b>25 – 8</b>
<b>Circuit Diagram.....</b>	<b>25 – 9</b>
<b>Routing Diagram .....</b>	<b>25 – 10</b>
<b>Service Standard.....</b>	<b>25 – 11</b>
<b>Valve Clearance.....</b>	<b>25 – 17</b>
<b>Drive Chain .....</b>	<b>25 – 21</b>
<b>Radiator Disassembly .....</b>	<b>25 – 23</b>
<b>Clutch Disassembly .....</b>	<b>25 – 24</b>

# CBR250RR (R)

# Supplement

## Specification

Name		Honda MC22			
Length		1.975m			
Width		0.675m			
Height		1.080m			
Wheel base		1.345m			
Powerplant type		MC14E			
Total displacement		0.249l			
Type of fuel		Petrol			
Vehicle weight	Front	81kg			
	Rear	77kg			
	Total	158kg			
Maximum capacity		2			
Vehicle gross weight	Front	102kg			
	Rear	166kg			
	Total	268kg			
Tyres	Front	110/70R17 54H			
	Rear	140/60R17 63H			
Minimum clearance		0.130m			
Performance	Brake stop distance (initial km/h)		14.0m (50km/h)		
	Minimum turning radius		2.9m		
Powerplant	Starting system		Electric		
	Type		Petrol 4 cycle		
	Cylinder layout		Inline 4 cylinder		
	Combustion chamber		Pent Roof type		
	Valve operation		DOHC gear driven, inlet 2, exhaust 2		
	Bore x stroke		48.5 x 33.8mm		
	Compression ratio		11.5		
	Compression		13.0kg/cm <sup>2</sup> - 400rpm		
	Maximum output		40PS/14,500rpm		
	Maximum torque		2.4kg-m / 11,500rpm		
	Valve Operation	Inlet	Open	20°BTDC (1mm lifted)	
			Close	20°ABDC (1mm lifted)	
		Exhaust	Open	29°BBDC (1mm lifted)	
			Close	3°BTDC (1mm lifted)	
	Valve clearance		IN 0.16mm (cool)		
			EX 0.23mm (cool)		
	Unloaded rev		1,500rpm		
	Lubrication	Type		Compress – spray	
		Pump type		Trochoid	
		Filter type		Total flow filtering Screen and paper	
Oil capacity		2.7l			
Cooling system		Water cooled, electrical			
Fuel System	Air filter type		Filter paper		
	Fuel tank capacity		13.0l		
	Carburetor	Type		VP20	
		Throttle valve diameter		30mm	
Venturi diameter		29mm			
Electrical System	Ignition system	Type		Full transistor, battery ignition	
		Timing		20°BTDC / 1,500rpm	
		Spark plug	NGK	CR 9 EH 9, CR10EH 9	
			ND	U27FER-9, U31FER-9	
	Plug gap		0.8 – 0.9mm		
Battery capacity		12V 6AH			
Transmission	Clutch	Type		Multiple wet spring coil	
		Operation		Mechanical	
	Motor to transaxle ratio		2.966		
	Gear Reduction	Gear Ratio	Type		Constant Mesh
			Low	Second	2.733
				Third	2.000
				Fourth	1.333
			Fifth	1.153	
				Sixth	1.035
	Reduction	No 1	Gear type	Chain	
Reduction ratio			3.058		
Wheels	Front	Caster		24°00'	
		Trail		89mm	
	Tyre pressure		Front	2.25kg / cm <sup>2</sup>	
		Rear	2.50kg/cm <sup>2</sup>		
Steering angle		Front	31°		
		Rear	31°		
Brake system		Front	Hydraulic disc brake		
		Rear	Hydraulic disc brake		
Suspension		Front	Telescopic		
		Rear	Swing arm		
Frame type		Diamond			
Frame number		MC22 – 1100001			
Engine number		MC14E - 1400001			

# CBR250RR (R)

# Supplement

## • Torque Settings Engine

Part	Qty	Screw Dia (mm)	Torque (kg-m)	Notes
Cylinder head cover special bolt	6	6	0.8 – 1.2	
Camshaft holder flange bolt	16	6	1.2 – 1.6	
Cylinder head flange bolt 7mm	9	7	2.7 – 3.0	Apply oil
8mm	1	8	2.4 – 2.7	Apply oil
Spark plug	4	10	1.0 – 1.4	
Connecting rod (connecting rod bolt / nut)	8	-	1.6 – 2.0	Apply oil
Gear train holder bolt	2	8	1.8 – 2.2	
Alternator flywheel	1	10	8.0 – 9.0	UBS
Starter clutch	1	10	8.0 – 9.0	UBS
Clutch centre lock nut	1	20	10.0–12.0	Stake
Oil pump driven sprocket flange bolt	1	6	1.3 – 1.7	Apply screw locker
Oil pressure switch	1	PT / 1/8	1.0 – 1.4	Apply sealant
Neutral switch	1	10	1.0 – 1.4	
Oil filter centre bolt	1	20	1.5 – 2.0	
Drain plug bolt	1	14	2.5 – 3.5	
Crankcase flange bolt 6mm	16	6	1.0 – 1.4	Apply oil
8mm	11	8	2.1 – 2.5	Apply oil
Shift drum centre (shifter pin)	1	-	2.1 – 2.5	Apply screw locker
Gear shift return spring pin	1	8	2.1 – 2.5	
Centre shift fork lock bolt	1	7	1.6 – 2.5	
Lower crankcase	1	18	4.0 – 5.0	Apply screw locker
Timing hole cap	1	14	0.8 – 1.2	
Crankshaft hole cap	1	30	0.8 – 1.2	
Drive sprocket special bolt	1	10	5.0 – 6.0	
Carburetor synchronisation joint	4	5	0.2 – 0.3	

## Frame

Part	Qty	Screw Dia (mm)	Torque (kg-m)	Notes
Engine mount Front right	1	10	4.5 – 5.5	
Front left	1	10	4.5 – 5.5	
Rear upper	1	10	4.5 – 5.5	
Rear lower	1	10	4.5 – 5.5	
Rear upper bracket	2	8	3.0 – 4.0	
Rear lower bracket	2	10	4.5 – 5.5	
Sub frame Upper	2	10	4.5 – 5.5	
Lower	2	10	4.5 – 5.5	
Side stand bracket bolt	2	10	4.5 – 5.5	
Side stand pivot bolt / nut	1/1	10	4.5 – 5.5	
Handlebar split bolt	2	8	2.4 – 3.0	
Handle weight mount screw	2	6	0.7 – 1.1	
Handle lever bracket bolt	4	6	0.7 – 1.1	
Radiator mount bolt upper	2	6	1.0 – 1.4	
Lower	1	6	1.0 – 1.4	
Fan motor switch	1	16	1.5 – 2.0	
Thermostat case mount bolt	2	6	1.0 – 1.4	
Water hose strap	-	-	0.1 – 0.2	
Fuel tank mount bolt Front	1	6	1.0 – 1.4	
Rear	1	8	2.4 – 3.0	
Fuel cock mount nut	1	22	3.0 – 4.0	
Fuel cock lever mount bolt	1	4	0.2 – 0.3	
Fuel cap socket bolt	3	4	0.2 – 0.3	

# CBR250RR (R)

# Supplement

Part	Qty	Screw Dia (mm)	Torque (kg-m)	Notes	
Air filter case screw	13	5	0.1 – 0.2		
Air filter case front stay bolt	1	6	1.0 – 1.4		
Upper cowl socket bolt	1	6	0.7 – 1.1		
Upper cowl stay A	2/2	8	2.4 – 3.0		
Instruments mount bolt	2	6	1.0 – 1.4		
Horn mount bolt	1	6	1.0 – 1.4		
Headlamp mount bolt	3	6	1.0 – 1.4		
Upper cowl stay B SH bolt	2	6	1.0 – 1.4		
Rearview mirror cap nut	4	6	0.8 – 1.2		
Upper cowl stay C	2	6	1.0 – 1.4		
Steering stem adjust nut	1	26	2.0 – 2.4		
Steering stem nut	1	24	9.0 – 12.0		
Bottom bridge split bolt	2	10	3.0 – 4.0		
Top bridge split bolt	2	8	2.0 – 2.5		
Rear axle nut	1	16	8.0 – 10.0		
Front axle bolt	1	14	5.5 – 6.5		
Axle holder split bolt	4	8	1.8 – 2.5		
Front brake disc bolt	12	8	4.0 – 4.5		
Driven sprocket nut	6	8	2.8 – 3.4		
Rear brake disc bolt	4	6	1.8 – 2.2		
Brake hose oil bolt	6	10	3.0 – 4.0		
Rear brake caliper slide pin - Main	1	12	2.5 – 3.0		
- Sub	1	8	2.0 – 2.5		
Hanger pin	3	10	1.5 – 2.0		
Hanger pin plug	3	10	0.2 – 0.3		
Brake bleeder valve	3	8	0.4 – 0.7		
Front brake caliper mount bolt	4	8	2.8 – 3.4		
Rear master cylinder hose joint screw	1	4	0.1 – 0.2		
Rear master cylinder push rod joint nut	1	8	1.5 – 2.0		
Front brake master cylinder cap screw	2	4	0.1 – 0.2		
Front brake switch screw	1	4	0.08 – 0.15		
Brake lever pivot bolt	1	6	0.05 – 0.15		
Brake lever pivot nut	1	6	0.5 – 0.7		
Front brake master cylinder holder nut	2	6	1.0 – 1.4		
Rear fork pivot nut	1	14	6.0 – 7.0		
Drive chain slider screw	2	6	0.45 – 0.60		
Rear fork pivot adjust bolt	1	26	1.0 – 2.0		
Rear fork adjust bolt lock nut	1	26	6.0 – 7.0		
Fork bolt	2	34	1.5 – 3.0		
Fork damper lock nut	2	8	1.5 – 2.5		
Rear cushion mount bolt	Upper	1	10	4.5 – 5.5	
Lower	1	10	4.5 – 5.5		
Cushion connecting rod	Frame end	1	10	4.5 – 5.5	
Cushion arm end	1	10	4.5 – 5.5		
Cushion arm	Swing arm end	1	10	4.5 – 5.5	
Rear cushion plate screw		3	5	0.5 – 0.7	Apply screw locker
Lower cowl socket bolt		6	6	0.7 – 1.1	
Lower cowl stay	Right upper	1	6	0.7 – 1.1	
Left upper	1	6	1.0 – 1.4		
Lower	2	6	0.7 – 1.1		
Change arm flange bolt		1	6	1.4 – 1.8	
Exhaust pipe joint nut		8	6	1.0 – 1.4	
Muffler mount bolt / nut		2/2	8	2.4 – 3.0	
Silencer mount bolt		3	6	1.6 – 2.0	
Step holder socket bolt		4	8	2.4 – 3.0	
Rear master cylinder mount bolt		2	6	1.0 – 1.4	

# CBR250RR (R)

# Supplement

Part	Qty	Screw Dia (mm)	Torque (kg-m)	Notes
Pillion step holder flange bolt	4	8	2.4 – 3.0	
Pillion step lock lever bolt	2	6	1.0 – 1.4	
Rear fender mount bolt	4	6	1.0 – 1.4	
Rear turn signal screw	2	5	0.35 – 0.50	
Reflector nut	1	6	0.7 – 1.1	
Front fender mount bolt	4	6	0.7 – 1.1	
Side cover socket bolt	4	6	0.7 – 1.1	
Side cover joint screw	1	5	0.35 – 0.50	
Side cover hook socket bolt	2	6	1.0 – 1.4	
Seat cowl screw	2	5	0.3 – 0.4	
Seat screw	2	5	0.35 – 0.50	
Pillion seat catch	1	6	1.0 – 1.4	
Drive chain case bolt	1	6	0.8 – 1.2	
Throttle cable adjust nut (carburetor end)	1	6	0.8 – 1.2	
Throttle housing screw	2	5	0.35 – 0.50	
Clutch cable nut (engine side)	1	8	0.8 – 1.2	
Choke cable screw (carburetor side)	1	4	0.15 – 0.30	
Ignition coil bracket bolt	4	6	1.0 – 1.4	
Ignition coil screw	2	6	0.7 – 1.1	
Ignition switch socket bolt	2	8	2.4 – 3.0	
Tail lamp cap nut	2	6	0.8 – 1.2	

**Lubrication & Sealant**  
**Engine**

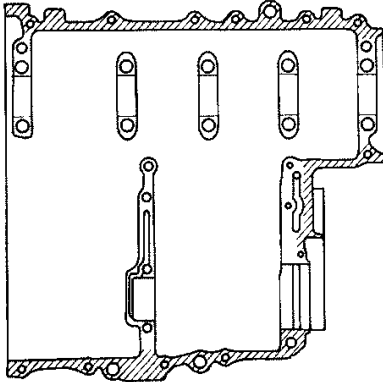
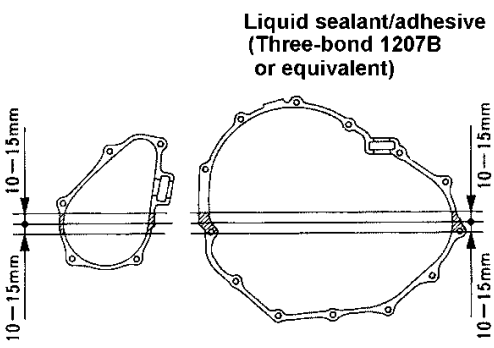
Application	Notes	Type
Main journal bearing Connecting rod bearing Crankshaft journal Camshaft bearing and cam Transmission shift fork groove Intake / Exhaust valve stem Clutch primary driven gear / sub gear Clutch outer needle bearing Starter reduction gear shaft Connecting rod small end C1 gear collar Valve lifter Primary drive gear / sub gear 10 x 44mm pin		Molybdenum solution (engine oil: Molybdenum grease = 1:1)
Piston, piston ring and piston pin Pulse generator rotor mount bolt Cylinder head bolt (7mm) thread and seat Connecting rod nut thread and seat Clutch centre lock nut thread and seat Flywheel bolt thread and seat Starter one way clutch lock surface Clutch disc lining Clutch lifter pin Each gear / bearings Each O-Ring Other moving surface		Engine oil
Each oil seal lips Crankshaft wheel cap thread and seat		Multi purpose grease
Crankcase mating surface  <b>Crankcase mating surface</b> 	Liquid sealant / adhesive (three bond 1207B or equivalent)	 <p style="text-align: center;"><b>Liquid sealant/adhesive (Three-bond 1207B or equivalent)</b></p>

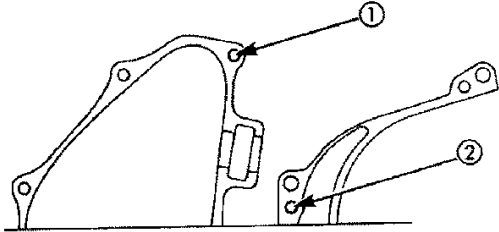
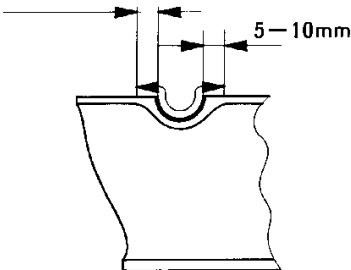

Application	Notes	Type
Oil pressure switch thread Thermo – sensor thread		sealant
Cylinder block sealing bolt thread Cylinder head sealing bolt thread Drive sprocket cover bolt thread (6 x 25mm) (1) Left crankcase cover mount bolt thread (2)  Breather plate bolt thread Lower crankcase sealing bolt thread Alternator lead clamp bolt thread Main bearing set plate bolt thread Oil pipe mount bolt thread/seat (block side) Left crankcase cover plate bolt thread Shift drum bearing set plate bolt thread Oil pump driven sprocket bolt thread Shift drum centre bolt thread Drive chain guide plate bolt thread Starter clutch outer bolt thread Pulse generator bolt thread		
Cylinder head camshaft plug half-round section  <b>Cylinder head camshaft plug                      half-round section</b> 		Three bond #5211C or equivalent

**Frame**

<b>Application</b>	<b>Notes</b>	<b>Type</b>
Rear brake pedal pivot Throttle grip pipe Left handle lever pivot Gear shift pedal pivot Seat catch hook Steering stem bearing Stem dust seal lip Pillion seat hinge		Multi purpose grease
Steering stem adjust nut thread		Engine oil
Side stand pivot		Molybdenum grease

**Special & Common Tools****Special Tool**

<b>Tool Name</b>	<b>Tool No.</b>	<b>Qty</b>	<b>Application</b>
Drive chain staking tool	07HMH – MR10103	1	Drive chain replacement

**25-9**

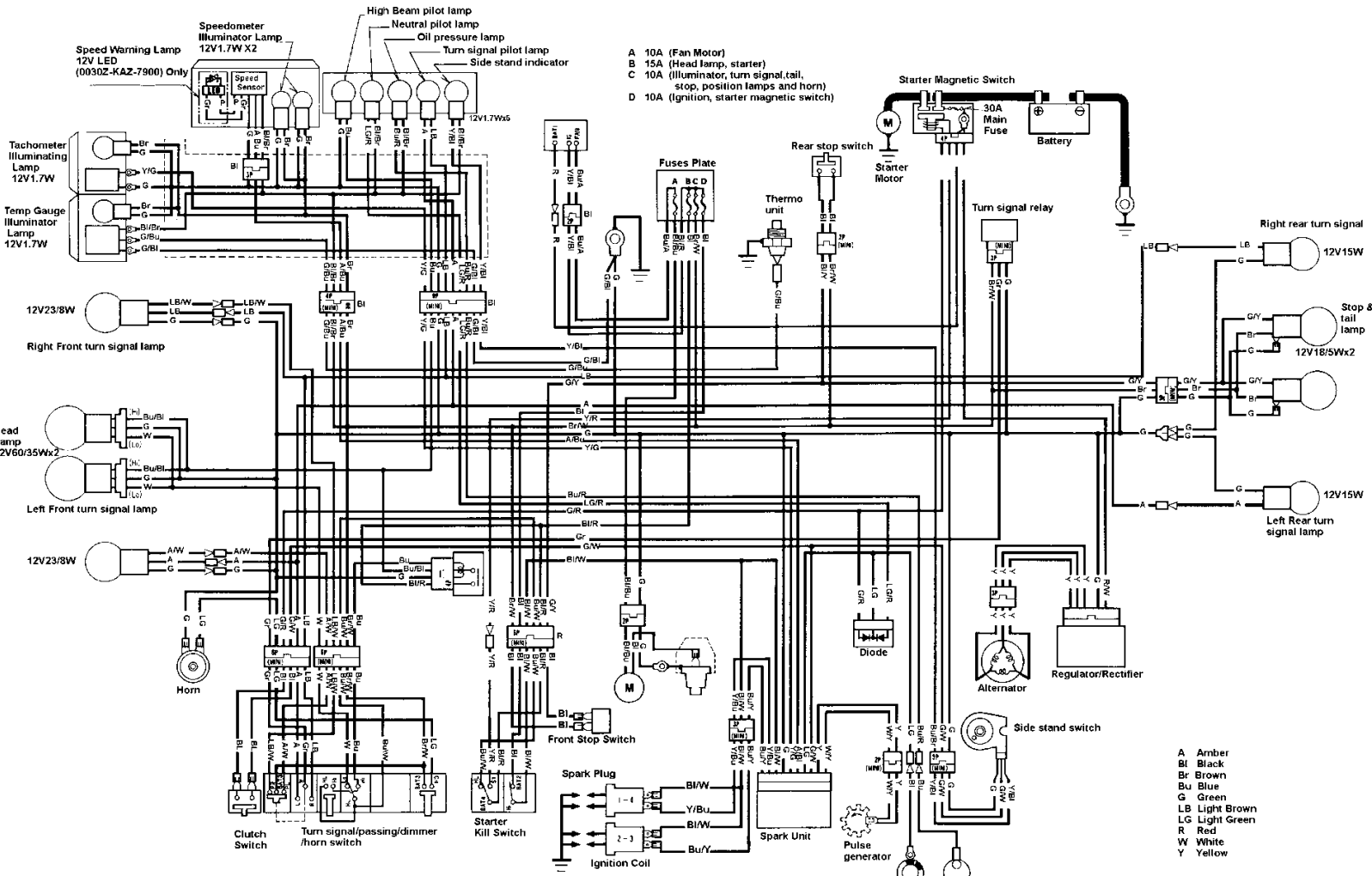

**SWITCH CONNECTION**

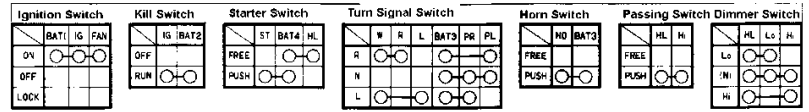

**0030Z-KAZ-7800  
-7900**

Routing Diagram

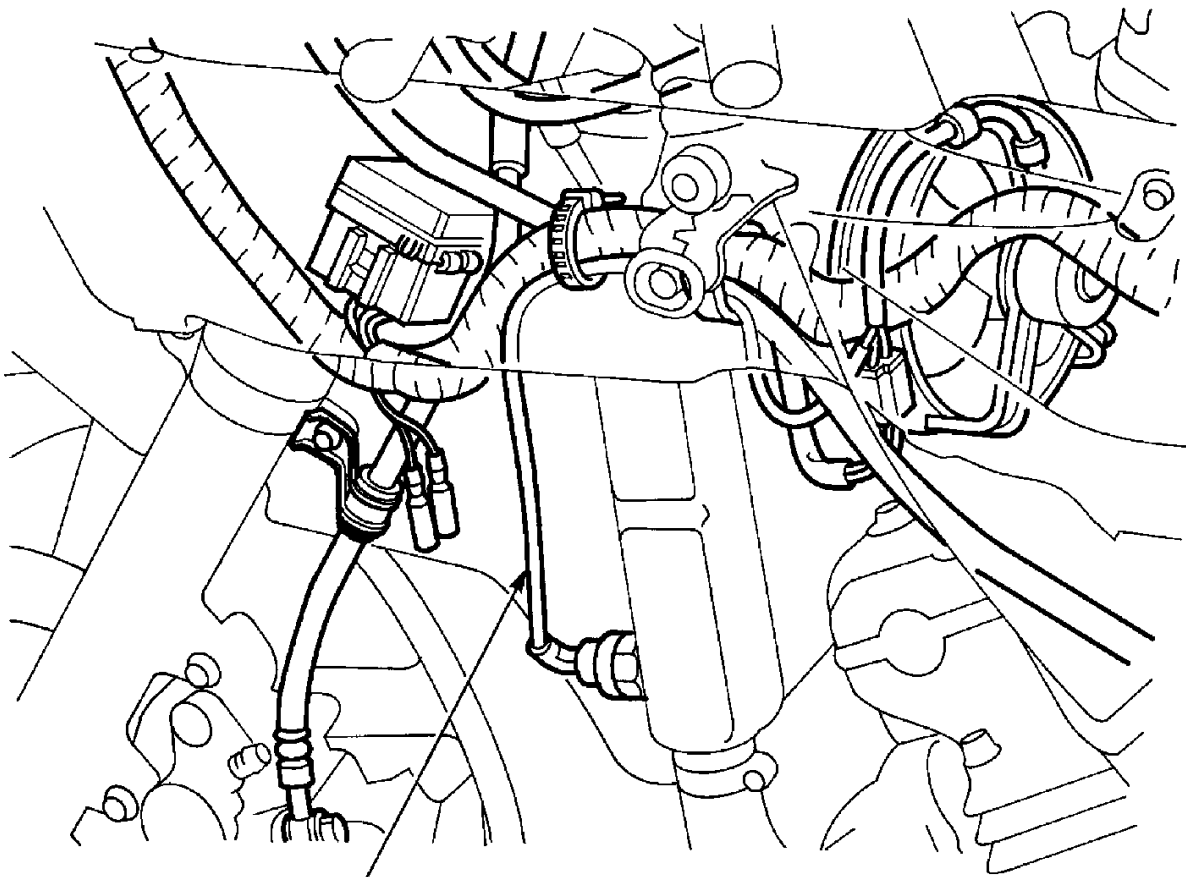

**Cooling fan wire**

# CBR250RR (R)

# Supplement

Unit : mm

Item	Standard	Standard	Service Limit
Oil Pump	Rotor tip clearance	0.15	0.20
	Pump body – outer rotor gap	0.15 – 0.22	0.35
	Rotor – body gap	0.02 – 0.07	0.10
	Pressure	4.0 – 5.0kg/cm <sup>2</sup> (6,000 oil temp 60°c)	

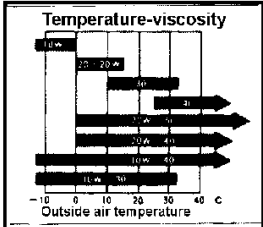
Engine oil capacity	2.2L(oil change) 2.4L (oil & filter change) 2.7L (total capacity)
Designated engine oil	<ul style="list-style-type: none"> <li>Genuine Honda Ultra GP (4 cycle motorcycle, SAE 10W – 40 or SAE 20W – 50)</li> </ul> <div style="border: 1px solid black; padding: 5px; width: fit-content; margin: 10px auto;">                     Select proper oil based on operation temperature.                 </div> 

## Fuel System

Item	Standard
Venturi Diameter	Primary bore 9.1mm equivalent, Secondary bore 29mm equivalent
Setting mark	VP20B
Float level	13.7mm
Main jet	No. 1, 4 : #112      No. 2, 3 : #110
Slow jet	#35
Idling rpm	1,500 ± 100rpm
Throttle grip free play	2 – 6mm
Pilot screw initial setting	2 1/8 turns out
Fuel tank capacity	Total
	Reserve
	13L
	Approx 1.6L

## Cooling System

Item	Standard	Service limit
Radiator cap valve opening pressure	1.10 – 1.40kg/cm <sup>2</sup>	Replace if out of the range: 1.10 ~ 1.40kg/cm <sup>2</sup>
Thermostat valve opening temperature	Opening temp	80 – 84°
	Full open	95°c
	Full open lift	8mm or above
Coolant capacity	Total approx: 1570cc (Radiator: 1350cc) (Reservoir: 220cc)	

## Engine Mounting / Dismounting

<b>Engine Weight (service)</b>		<b>Approx 48.5kg</b>
Recommended engine oil		"Genuine Honda Ultra GP (4 cycle motorcycle, SAE 10W – 40 or SAE 20W 50)" <ul style="list-style-type: none"> <li>• API classification SE, SF or SG grade oil (Refer to (3-2) for viscosity)</li> </ul>
Engine oil capacity	Total capacity	2.7L
	Oil change	2.2L
	Oil and filter change	2.4L

## Cylinder Head & Valve

Unit : mm

Item	Standard		Standard	Service Limit
Compression			13.0kg/cm <sup>2</sup> - 400rpm	-
Cam shaft	Cam lift	IN	28.72 – 28.80	28.69
		EX	28.51 – 28.75	28.48
	Oil clearance	1	0.015 – 0.057	0.06
		2	0.015 – 0.057	0.06
		3	0.025 – 0.067	0.07
		4	0.015 – 0.057	0.06
Runout		-	0.05	
Valve spring	Relaxed length		37.65	36.65
Valve & Valve guide	Valve stem diameter	IN	3.481 – 3.495	3.476
		EX	3.465 – 3.480	3.460
	Valve guide bore	IN	3.500 – 3.512	3.57
		EX	3.500 – 3.512	3.57
	Stem guide clearance	IN	0.005 – 0.032	0.10
		EX	0.020 – 0.047	0.13
Valve seat contact width	IN	0.8	1.3	
	EX	1.0	1.5	
Valve lifter	Diameter		19.978 – 19.993	19.970
Cylinder head	Warpage		-	0.05
	Valve lifter contact area bore		20.010 – 20.026	20.035

## Cylinder, Piston and Crankshaft

Unit: mm

Item		Standard	Service limit	
Crankshaft and connecting rod	Connecting rod big end side clearance	0.10 – 0.25	0.30	
	Crankshaft runout	-	0.05	
	Crank pin oil clearance	0.028 – 0.046	0.05	
	Main journal oil clearance	0.022 – 0.040	0.06	
Cylinder	Bore	48.500 – 48.510	48.60	
	Top warp	-	0.05	
	Out of round	-	0.005	
	Taper	-	0.005	
Piston Ring	Ring groove – ring clearance	Top	0.015 – 0.050	0.10
		Second	0.21 – 0.36	0.10
	Ring end gap	Top	0.1 – 0.25	0.45
		Second	0.15 – 0.30	0.45
		Oil (side rail)	0.2 – 0.8	1.00
Piston	Piston diameter	48.47 – 48.49	48.35	
	Piston – cylinder clearance	0.01 – 0.04	0.10	
	Piston pin hole diameter	13.002 – 13.008	13.02	
	Piston pin diameter	12.994 – 13.000	12.98	
	Piston – Piston pin clearance	0.002 – 0.014	0.04	
	Connecting rod small end bore	13.016 – 13.034	13.05	
	Piston pin – connecting rod clearance	0.016 – 0.040	0.06	

		Connecting rod bore code			
		1	2	3	
Crankpin diameter code	A	27.494-27.500mm	E (Yellow)	D (Green)	C (Brown)
	B	27.488-27.494mm	D (Green)	C (Brown)	B (Black)
	C	27.482-27.488mm	C (Brown)	B (Black)	A (Blue)

Bearing Metal Thickness:

A (Blue): 1.252-1.255mm  
 B (Black): 1.249-1.252mm  
 C (Brown): 1.246-1.249mm  
 D (Green): 1.243-1.246mm  
 E (Yellow): 1.240-1.243mm

		Case bore			
		A	B	C	
Main journal dia code	1	27.993-28.000mm	E (Pink)	D (Yellow)	C (Green)
	2	27.987-27.994mm	D (Yellow)	C (Green)	B (Brown)
	3	27.982-27.988mm	C (Green)	B (Brown)	A (Blue)

Bearing Metal Thickness:

A (Blue): 1.508-1.511mm  
 B (Brown): 1.505-1.508mm  
 C (Green): 1.502-1.505mm  
 D (Yellow): 1.499-1.502mm  
 E (Pink): 1.496-1.499mm

<b>Bl:</b> Black
<b>Br:</b> Brown
<b>Bu:</b> Blue
<b>G:</b> Green
<b>P:</b> Pink
<b>Y:</b> Yellow

## Clutch & Alternator

Item	Standard	Standard	Service Limit
Clutch	Clutch lever free play	10 – 20	-
	Clutch spring relaxed length	36	35
	Clutch disc thickness	2.9 – 3.0	2.6
	Clutch plate warpage	-	0.3
	Clutch outer guide bore	21.995 – 22.015	22.03
Oil pump drive sprocket bore		30.025 – 30.075	30.09
Oil pump drive gear collar	Bore	21.995 – 22.015	22.03
	Ex. dia	29.987 – 30.000	29.97
	Height	22.300 – 22.400	22.20
Main shaft diameter (at clutch outer guide)		21.980 – 21.990	21.97

## Transmission

Unit : mm

Item	Standard	Standard	Service Limit	
Transmission	Backlash		0.044 – 0.140	0.3
	Gear bore	M 5	25.000 – 25.021	25.05
		M 6	25.000 – 25.021	25.05
		C 1	23.000 – 23.021	23.05
		C 2	28.000 – 28.021	28.05
		C 3	28.000 – 28.021	28.05
		C 4	28.000 – 28.021	28.05
	Gear bush	M 5 bore	21.985 – 22.006	22.07
		M 5 diameter	24.959 – 24.980	24.92
		M 6 diameter	24.959 – 24.980	24.92
		C 1 diameter	22.959 – 22.980	22.92
		C 1 bore	20.020 – 20.041	20.11
		C 2 diameter	27.959 – 27.980	27.92
		C 3 diameter	27.959 – 27.980	27.92
		C 4 diameter	27.959 – 27.980	27.92
	Main shaft diameter	M 5	21.963 – 21.977	21.93
		Clutch outer guide	21.980 – 21.990	22.20
	Counter shaft diameter	C 1	19.987 – 20.000	19.77
	Gear bush or shaft clearance	M 5 bush	-	0.10
		M 5 bush-shaft	-	0.15
		M 6 bush	-	0.10
		C 1 bush	-	0.10
		C 1 bush-shaft	-	0.15
		C 2 bush	-	0.10
		C 3 bush	-	0.10
		C 4 bush	-	0.10
	Shift fork	Catch thickness	5.93 – 6.00	5.60
Bore		12.000 – 12.021	12.04	
Shift fork shaft	Diameter	11.960 – 11.971	11.90	



**Front Wheel and Suspension**

Item		Standard	Service limit
Front axle runout		-	0.2mm
Front wheel rim runout	Radial	-	2.0mm
	axial	-	2.0mm
Front cushion spring relaxed length		252.1	247mm
Front fork pipe runout		-	0.2mm
Front fork oil capacity	Standard	383 ± 2.5cc	-
	Fully compressed	83mm	-
Front fork air pressure		0 – 0.4kg/cm <sup>2</sup>	-

**Rear Wheel and Suspension**

Item		Standard	Service limit
Rear axle runout		-	0.2mm
Rear wheel rim runout	Radial	-	2.0mm
	Axial	-	2.0mm
Rear cushion damper compression (10mm compressed)		15.4kg	12.3kg
Rear cushion spring installation length		135mm	-
Rear cushion spring relaxed length		143.8mm	140.9mm

**Brake System (Disc Brake)**

Item		Standard	Service limit
Brake disc runout	Front	-	0.4
	Rear	-	0.3
Front master cylinder bore		12.700 – 12.743	12.755
Rear master cylinder bore		14.000 – 14.043	14.06
Front master piston diameter		12.657 – 12.684	12.65
Rear master piston diameter		13.957 – 13.984	13.95
Front caliper cylinder bore		25.400 – 25.450	25.46
Rear caliper cylinder bore		38.180 – 38.230	38.24
Front caliper piston diameter		25.335 – 25.386	25.33
Rear caliper piston diameter		38.098 – 38.148	38.09

## Battery and Charging System

Battery	Item	Standard
	Capacity	12V 6AH
	Charging Current	0.6A (10H)
	Discharging Voltage	13.0 – 13.2V (20°C)
Charging Start		2,000rpm
Regulator / Rectifier	Type	Non – contact type
	Regulated Voltage	14.0 – 15.0V
Alternator coil resistance (20°C)		0.1 – 0.5Ω
Alternator performance		270W / 5,000rpm

## Ignition System

Item		Standard	
Spark Plug		NGK	ND
		CR9EH – 9	U27FER – 9
		CR10EH – 9	U31FER – 9
Plug gap		0.8 – 0.9mm	
Ignition timing “F” mark		20°BTDC / 1,500rpm	
Ignition coil	Primary coil resistance (20°C)		2.0 – 3.5Ω
	Primary coil peak voltage		128V
	Secondary coil resistance (20°C)	With cap	23 – 37kΩ
		Without cap	13 – 17kΩ
Pulse Generator	Coil resistance (20°C)		340 - 420Ω
	Peak voltage		0.91 or above

## Self Starter

Item	Standard	Standard	Service Limit
Starter Motor	Brush spring tension	630 – 850g	-
	Brush length	11.00 – 11.05mm	4.5mm

## Lamps, Instruments and Switches

Item	Standard
Headlamp bulb	12V 60 / 35W x 2
Front turn signal bulb	12V 23 / 8 W x 2
Rear turn signal bulb	12V 15W x 2
Stop / Tail lamp bulb	12V 18 / 5 W x 2
Pilot lamps	12V 1.7 W x 4
Speed warning lamp (option)	LED
Tachometer, water temp gauge illuminator	12V 1.7 W x 2
Speedometer illuminator	12V 1.7 W x 2
Main fuse	30 A
Headlamp fuse	15 A
Other fuses	10 A x 3

## Valve Clearance

### Inspection

The valve clearance should be inspected when the engine is cool (35° c or less).

Remove the cylinder head cover (7-3).  
Remove the crankshaft hole cap and the timing hole cap.

Rotate the crankshaft clockwise and align the "T" mark on the crankshaft to the mark on the right crankcase cover.  
Make sure the "IN" and "EX" marks on cam gears are facing opposite directions (#1 cylinder TDC).

If the "IN" and "EX" marks are facing inwards, turn the crankshaft clockwise for one round.

Insert a thickness gauge between the camshaft and the valve lifter to measure the valve clearance on "IN" side of #1 & #3 cylinders.

**Valve clearance:** IN:  $0.16 \pm 0.03\text{mm}$

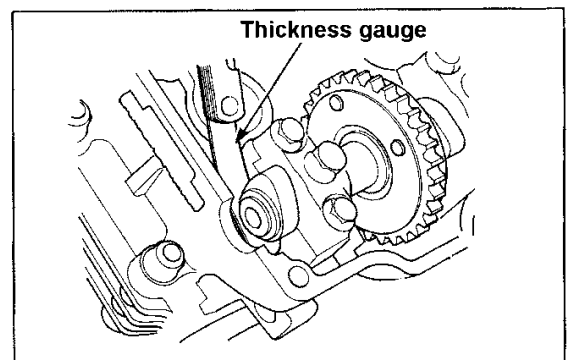
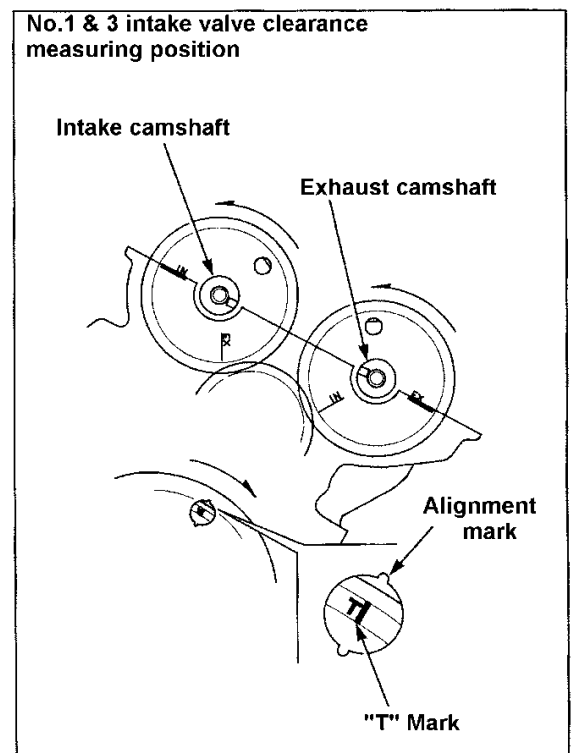
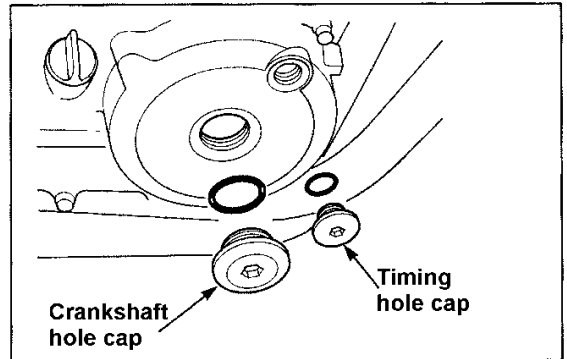

Turn the crankshaft 180° clockwise to align the "O" mark on the flywheel to the mark on the right crankcase cover.

Measure the valve clearance on "EX" sides of #2 & #4 cylinders.

**Valve clearance: EX:  $0.23 \pm 0.03\text{mm}$**

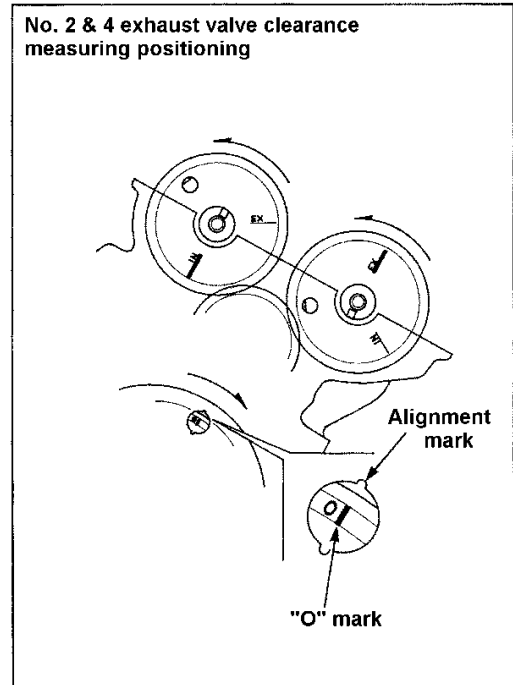

Turn the crankshaft clockwise to align the "T" mark on the flywheel to the mark on the right crankcase cover.

Measure the valve clearance on "IN" sides of #2 & #4 cylinders.

**Valve clearance: IN:  $0.16 \pm 0.03\text{mm}$**

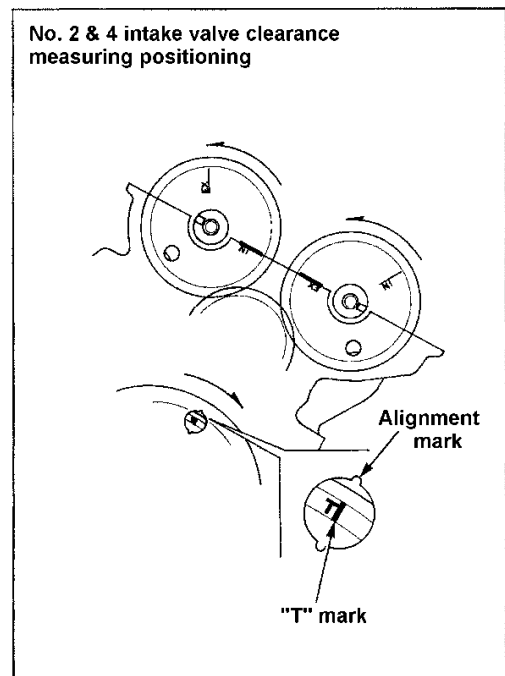

Turn the crankshaft 180° clockwise to align the "O" mark on the flywheel to the mark on the right crankcase cover.

Measure the valve clearance on "EX" sides of #1 & #3 cylinders.

**Valve clearance: EX:  $0.23 \pm 0.03\text{mm}$**

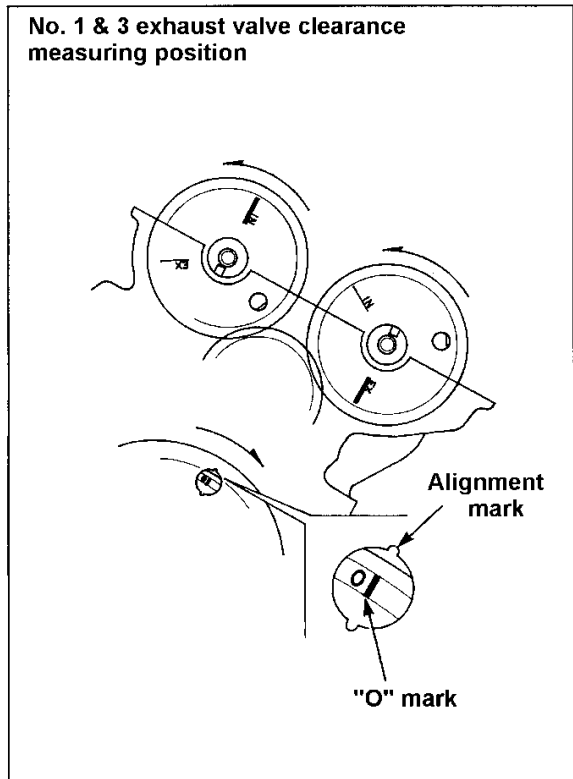

## Adjustment

Remove the camshaft (7-3).  
Remove valve lifters and shims.

- If the lifter is difficult to remove, use tools such as a valve wrapper.
- Shim may come out together with the valve lifter.
- If the shim is difficult to remove, use tweezers or a magnet.
- Re-install the lifters and the shims to the original position.
- Sort and store the lifters and shims.



Clean the valve lifter and the shim attachment with compressed air.

Wipe off oil on the shim and measure / record its thickness.

### How to select a new shim

There are 65 different types of shims, ranging from 1.200mm to 2.800mm with 0.025mm step.

Select the proper size by using the following equation:

$$A = B - C + D$$

Where

- A: new shim thickness
- B: measured valve clearance
- C: standard valve clearance
- D: removed (old) shim thickness

Example: Measured valve clearance: 0.16mm  
Removed shim thickness: 1.725mm  
Standard valve clearance: 0.21mm  
 $A = (0.16 - 0.21) + 1.725 = 1.675\text{mm}$

- Use a micrometer to measure new/old shim thickness accurately.
- If the required shim thickness is above 2.800mm remove built-up carbon on a valve seat to adjust it.

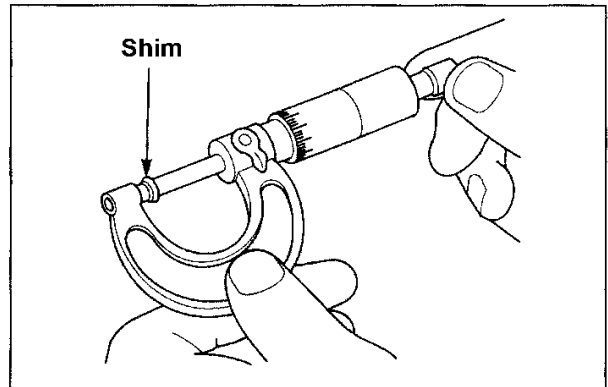

Install the selected shim to the valve spring retainer.

Apply Molybdenum dis-sulphide to the valve lifter and install the valve lifter.

Install the camshaft (7-19).

Turn the crankshaft several revolutions to ensure shim is settled.

Re-measure the valve clearance.

Install all removed parts by reversing the removal procedure.

Install the crankshaft hole cap and the timing hole cap.

- Inspect the O-Ring condition and replace if necessary.
- Apply grease to the cap thread.

### Torque:

**Crankshaft hole cap: 0.8 – 1.2kg-m**

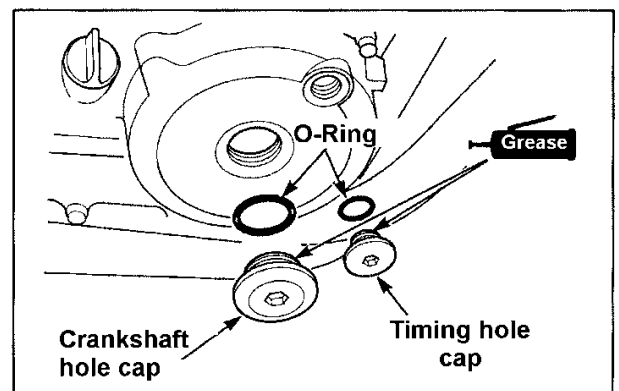
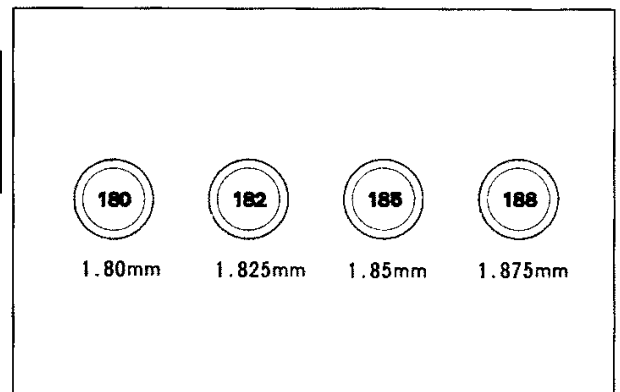

# CBR250RR (R)

# Supplement

Timing hole cap: 0.8 – 1.2kg-m

## Drive Chain

### Replacement

- CAUTION
- Use a special tool and genuine replacement chain to replace the drive chain.
- Never use clip-type chain.

Loosen the drive chain.  
Assemble the special tool.

### Special Tool:

Drive chain staking tool: 07HMH-MR10103

Read the instructions before using the staking tool.

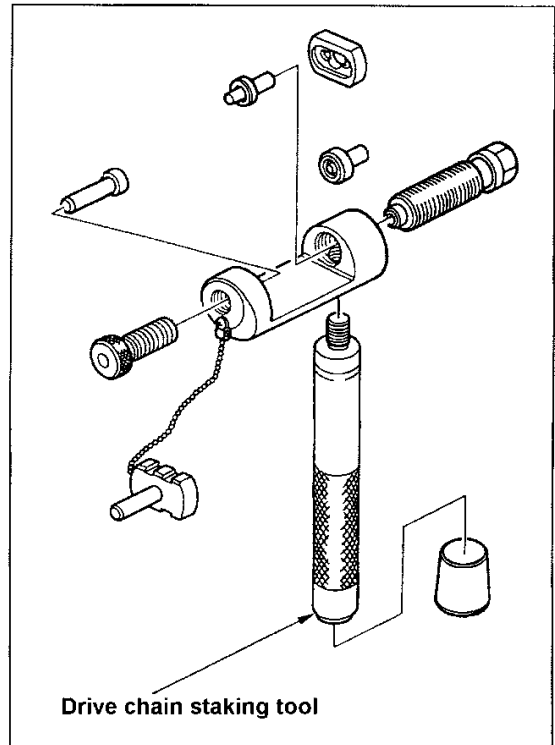

Set the tool to the staked section of the drive chain and cut the staked section.

### Special Tool:

Drive chain staking tool: 07HMH-MR10103

Adjust the number of links of the new drive chain by using the staking tool.

Include the master link to the number of links.

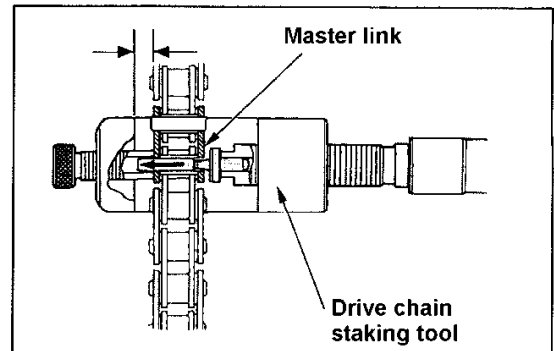

Standard links:

134 links

Replacement drive chain:

DID 428 VS1

RK 428 SHOZI

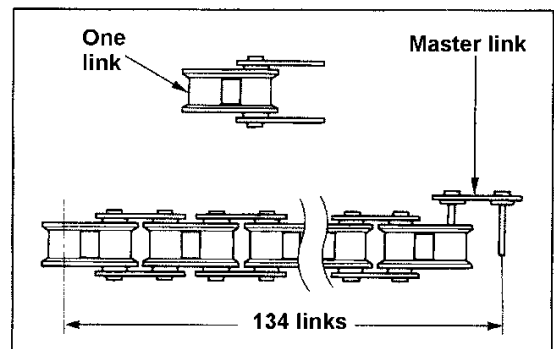

# CBR250RR (R)

# Supplement

Do not re-use the master link, the O-Ring, and the link plate.

Install O-Rings to the new master link and set the master link from inside of the chain.

- Install the master link plate so as to face its labeled surface outwards.
- Do not catch O-Rings.

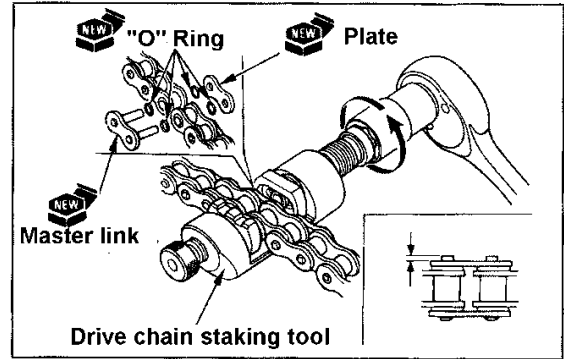

By using the staking tool, install O-Rings and the link plate to the link.

Confirm the end of the master link joint pins are coming out from the link plate.

**Standard:** RK – 1.0 ~ 1.2mm  
DID – 0.9 ~ 1.25mm

Stake the end of the joint pins.

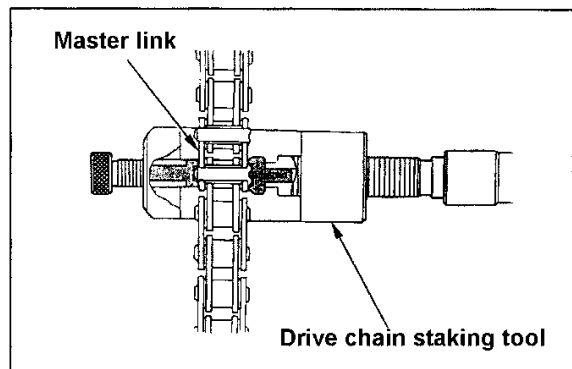

Measure the staked area with a caliper.

**Staked area:** 4.75 ~ 4.95mm

If the measured value is out of the above range, re-stake with a new master link, link plate and O-Rings.

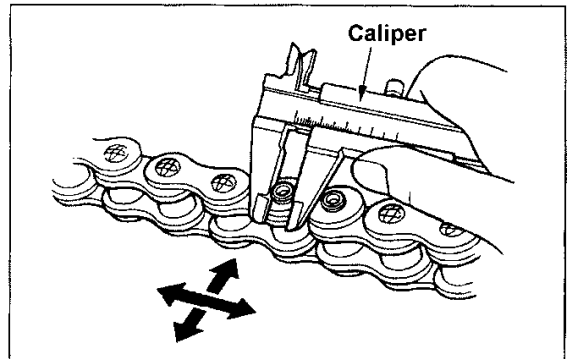

Make sure there is no crack on the staked area. If there is any crack, re-stake with the new master link, link plate and O-Rings.

**Caution :** Never use clip-type chain.

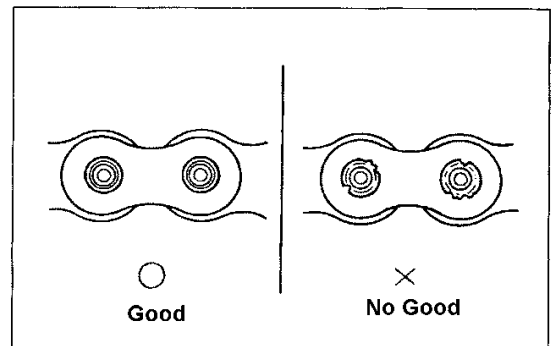



Radiator Disassembly

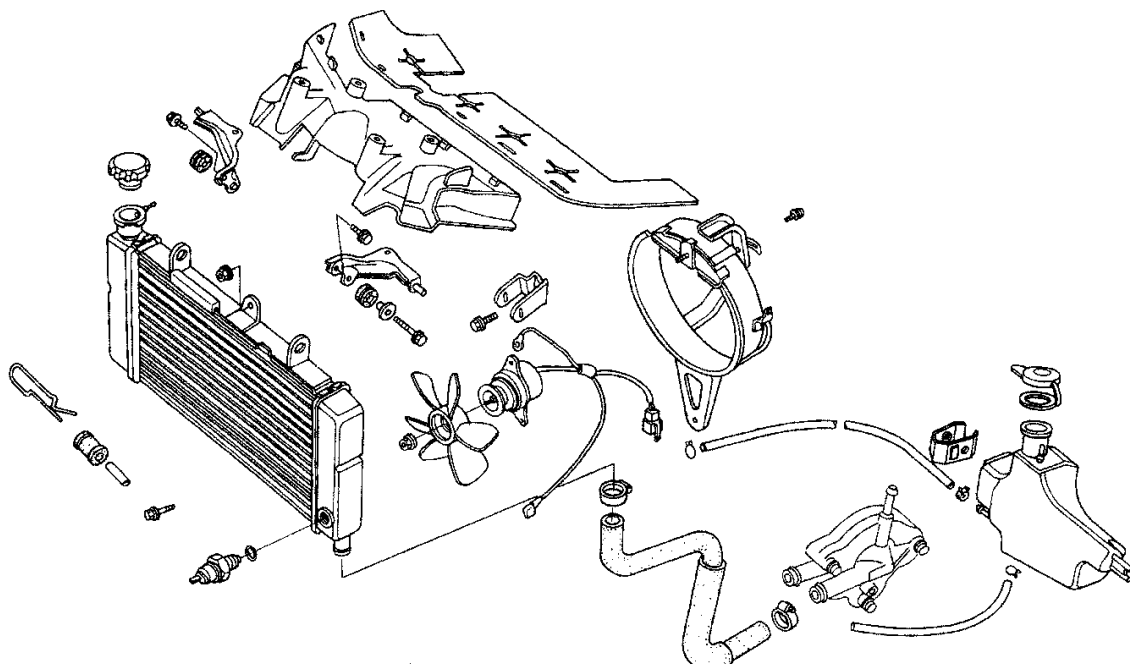

## Clutch Disassembly

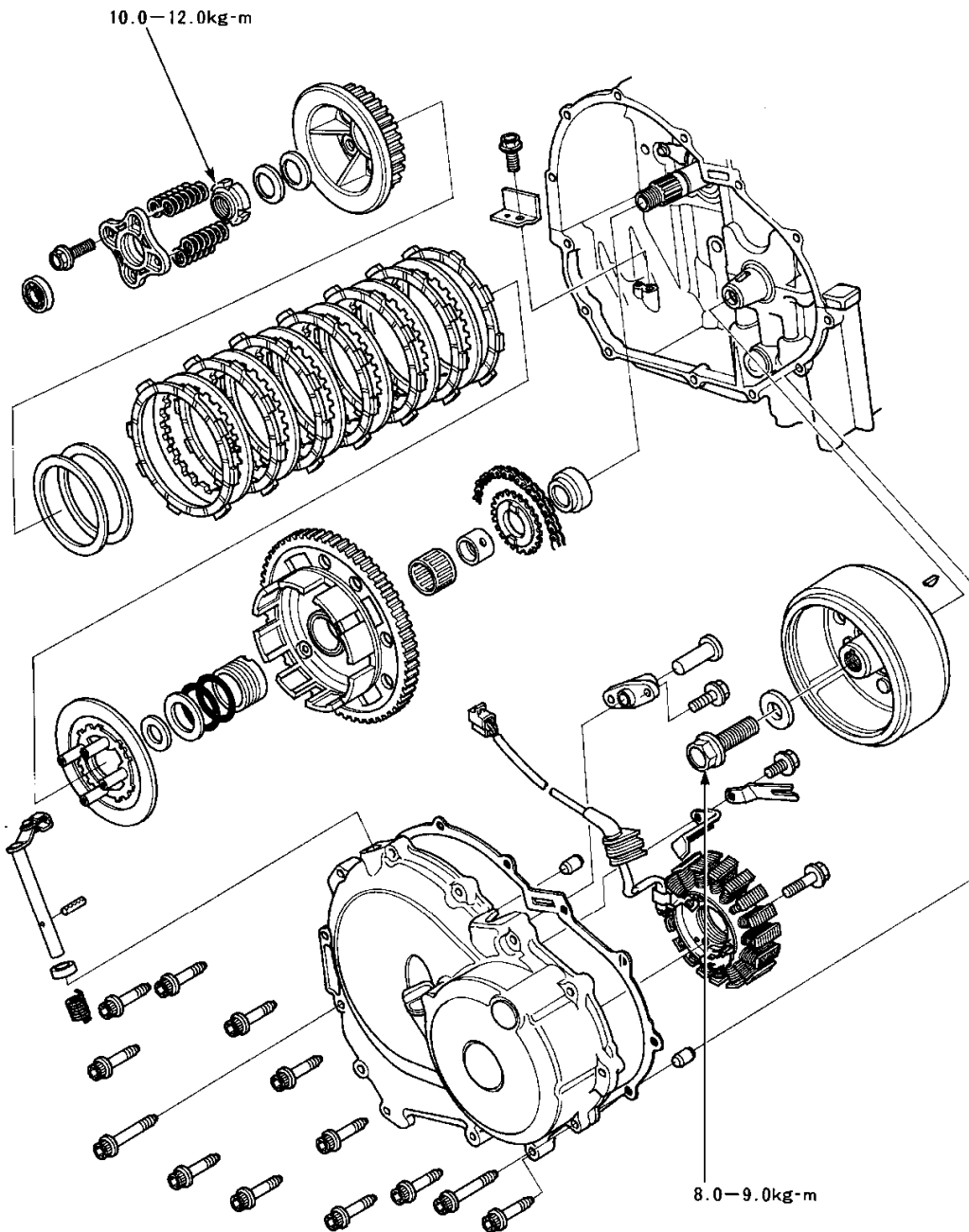

To print chapters, click on the printer icon and fill in the page range.

1.	Maintenance Information	3 - 44
2.	Inspection/Adjustment	45 - 64
3.	Oil lubrication	65 - 75
4.	Fuel system	76 - 95
5.	Cooling system	96 - 107
6.	Engine removal/Installation	108 - 113
7.	Cylinder head/Valve	114 - 136
8.	Crankcase	137 - 142
9.	Cylinder/Piston/Crankshaft	143 - 155
10.	Clutch/AC Generator	156 - 170
11.	Gear shift linkage	171 - 178
12.	Transmission	179 - 188
13.	Front wheel/Suspension/Steering	189 - 219
14.	Rear wheel/Brake/Suspension	220 - 243
15.	Braking system (Disc Brake)	244 - 255
16.	Exhaust pipe/Rear fender	256 - 258
17.	Battery Charger	259 - 264
18.	Ignition system	265 - 270
19.	Self starter system	271 - 284
20.	Lights/Instruments/Switches	285 - 294
21.	CBR250R(H)	295 - 337
22.	CBR250R(J)	338 - 374
23.	CBR250R(K)	375 - 377
24.	CBR250RR(L)	378 - 446
24.	CBR250RR(R)	447 - 470