



8

LISTE DES OPERATIONS FIGURANT AU CHAPITRE :
ESSIEU ARRIERE

VEHICULE CONCERNE
TYPE MOTEUR

1

NUMERO DE L'OPERATION	DESIGNATION	GAMME		20	22	25	25	25	25	25	25	25	Break 20	Break 25	Break 25	Break 25	Ambulance		
		TEXTES △	SYMBLES ○	Essence	Essence	Essence Injection	Prestige	Essence Turbo	Prestige Essence Turbo	Diesel	Diesel Turbo	Limousine Diesel Turbo	Essence + Familiale	Essence Injection	Diesel + Familiale	Diesel Turbo			
				829 A 5	J6T A 500	25/659	25/659	25/662	25/662	25/660	25/648	25/648	829 A 5	25/659	25/660	25/648	829A5 ou 25/660		
MA 420/1			○	X	X	X	X	X	X	X	X	X	X	X	X	X	X		
MA 420.00/1	Caractéristiques et points particuliers de l'essieu arrière		○	X	X	X	X	X	X	X	X	X	X	X	X	X	X		
MA 422.1/1	Dépose et pose d'un bras d'essieu arrière	△		X	X	X	X	X	X	X	X	X	X	X	X	X	X		



8



MA
420.00/1

1

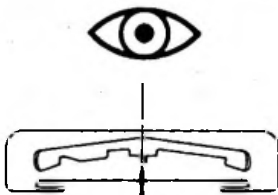
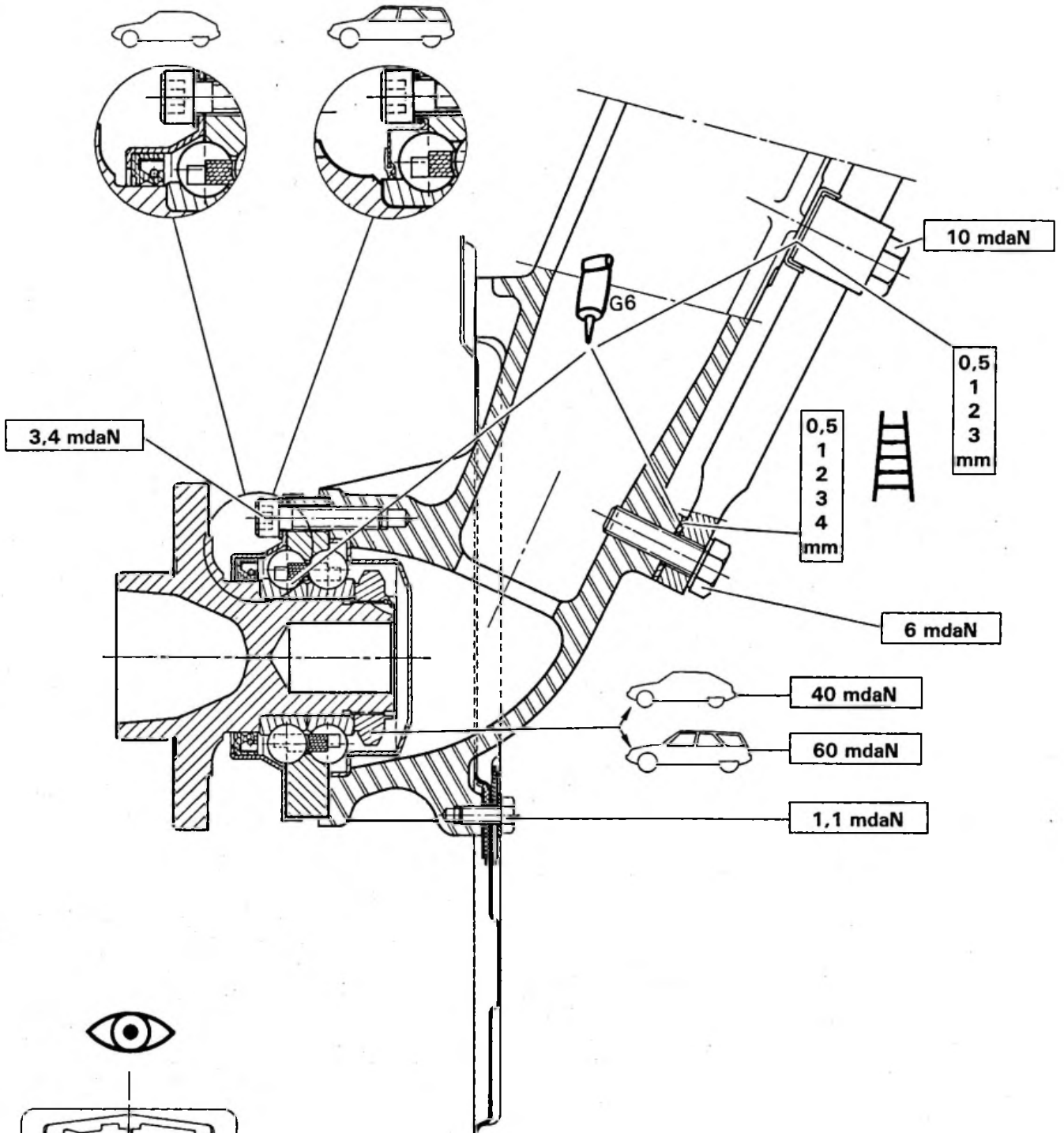

→ 7/85



7/85 →

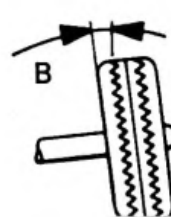
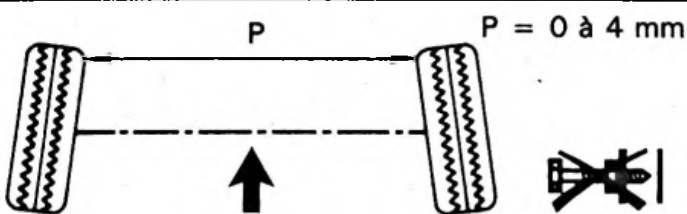

$B = 0^\circ - 0 24''$

*

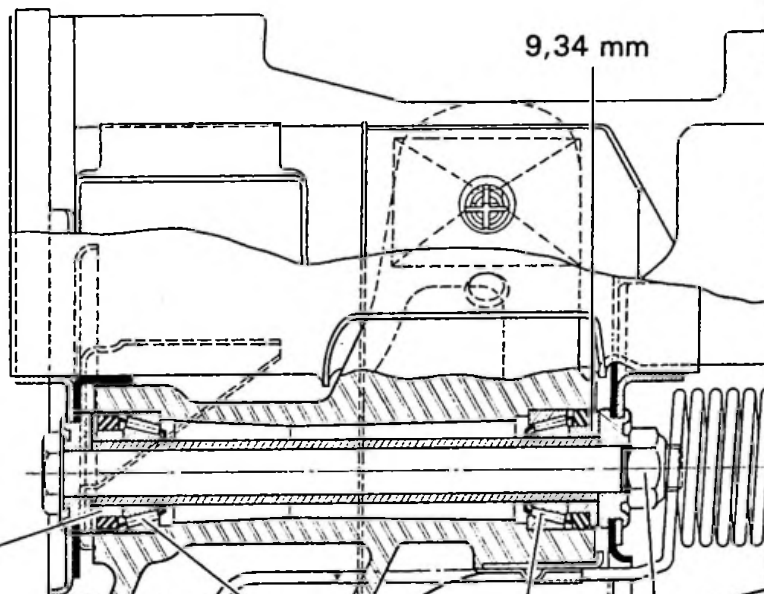
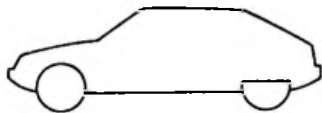

9,34 mm

10,04 mm



0,14 mm

12,5 mdaN

G6

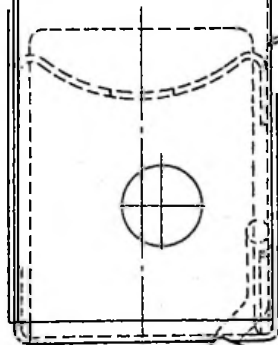
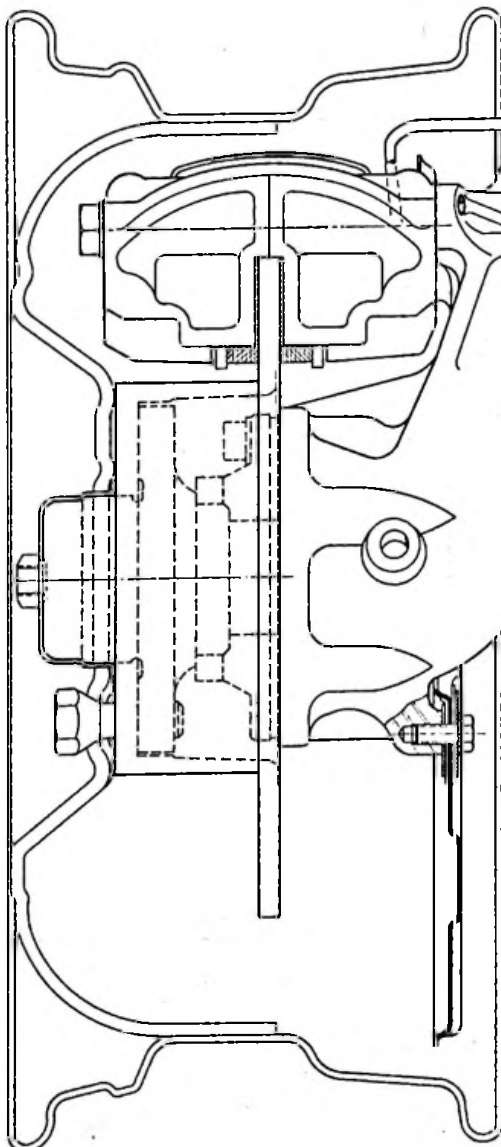



8



MA
420.00/1

3

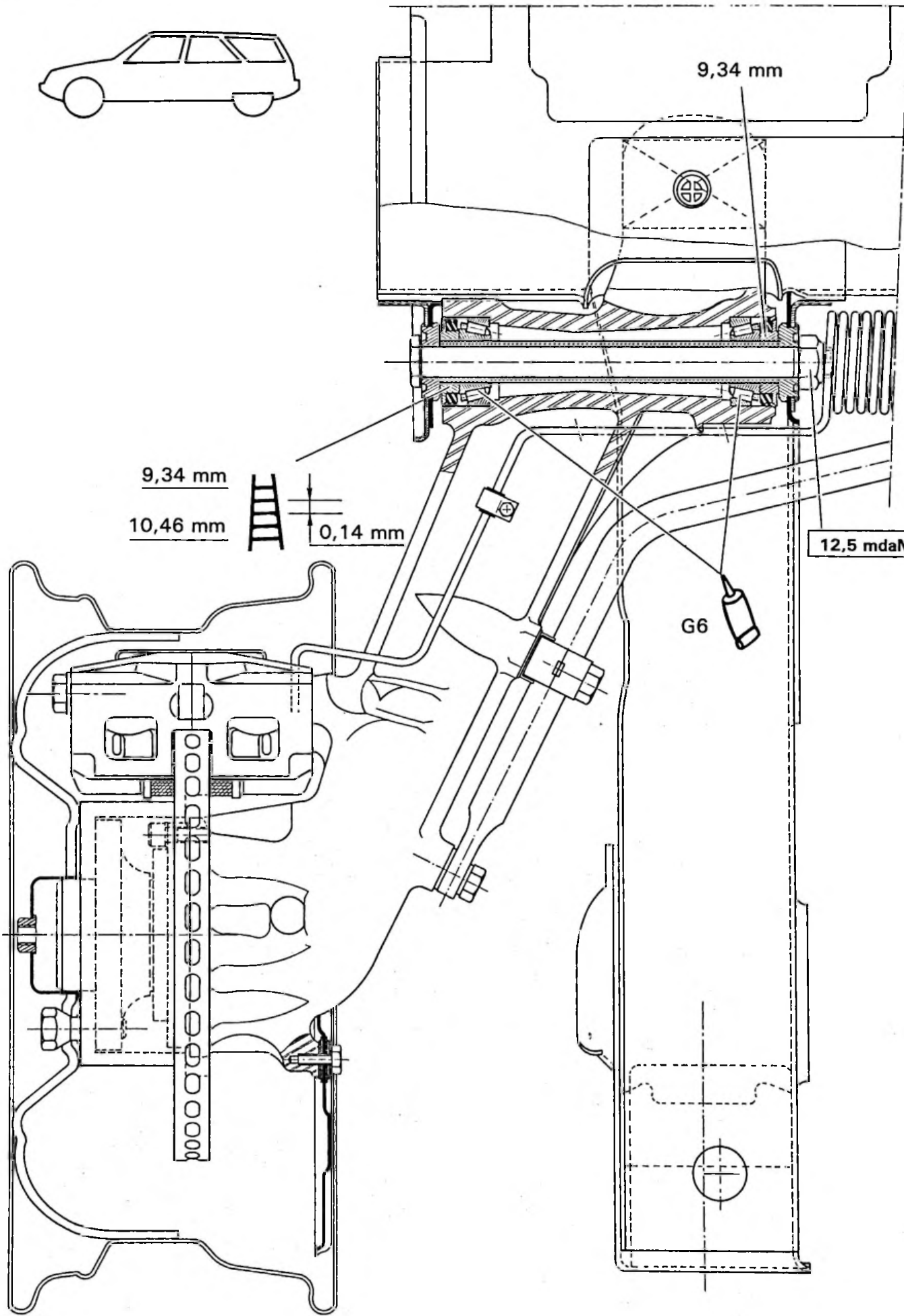
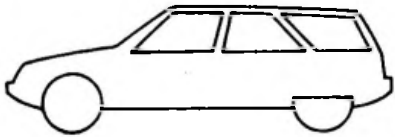

*



8

ESSIEU ARRIERE

MA
422.1/1

1

DEPOSE ET POSE D'UN
BRAS D'ESSIEU ARRIERE

**DEPOSE**

Caler l'arrière du véhicule roues pendantes

Déposer la roue

faire chuter la pression dans les circuits hydrauliques.

Déposer la tôle de protection (1) Fig. I.

Véhicule équipé de l'A.B.S. Fig. II

Déposer le capteur (3) et écarter sur le côté la tôle et le capteur en dégageant le faisceau des agrafes de maintien.

Déposer Fig. III le cylindre de suspension (5)
(Voir ⑨ MA 433-1/2.

Déposer la patte de maintien (4) Fig. III.

Désaccoupler :

- le tube de frein (2) Fig. I
- la barre anti-devers Fig. III pour cela déposer les vis (6) et (7) et conserver les cales et rondelles de calage situées en «a» et «b».

Déposer l'écrou (8) Fig. IV.

(24 mm sur plat)

Dégager l'axe et déposer le bras.

POSE

Poser le bras (la coupelle d'appui (9) la moins épaisse : 9,34 mm en «c» côté intérieur Fig. V).

Mettre en place l'axe.

Poser l'écrou (8) Fig. IV serrage à 13 m.daN
(Nylstop NEUF).

Accoupler la barre anti-devers Fig. III, poser les vis (6) et (7) avec les cales et rondelles de réglage trouvées au démontage en «a» et «b».

Serrage des vis (7) 6 m.daN et (6) 10 m.daN.

Accoupler le tube de frein (2) Fig. I, serrer (garniture joint NEUVE).

Poser la patte de maintien (4) Fig. III.

Poser le cylindre de suspension (5) Fig. IV
(Voir ⑨ MA 433-1/2..

Véhicule équipé de l'A.B.S. Fig. II

Poser le capteur (3) (enduire le corps du capteur de graisse MOBIL TEMP N° 1).

Serrer la vis à 1 m.daN.

Poser :

- la tôle de protection (1) Fig. I
- la roue.

Mettre le véhicule au sol.



8

MA
422.1/1

3

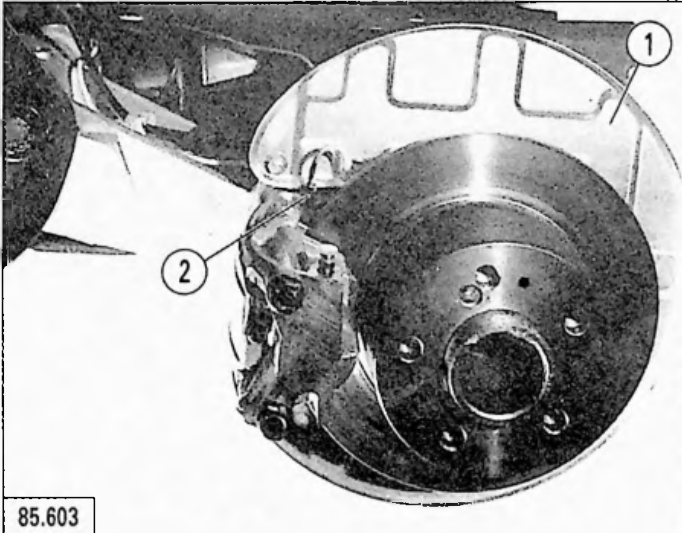

85.603

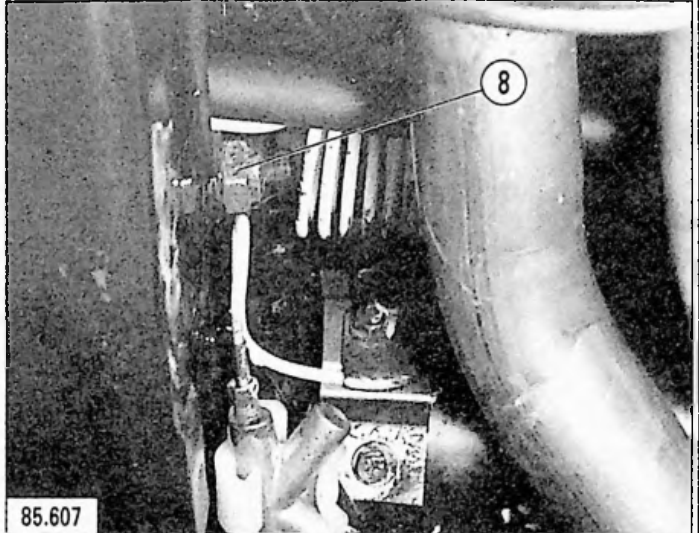

85.607

I

IV

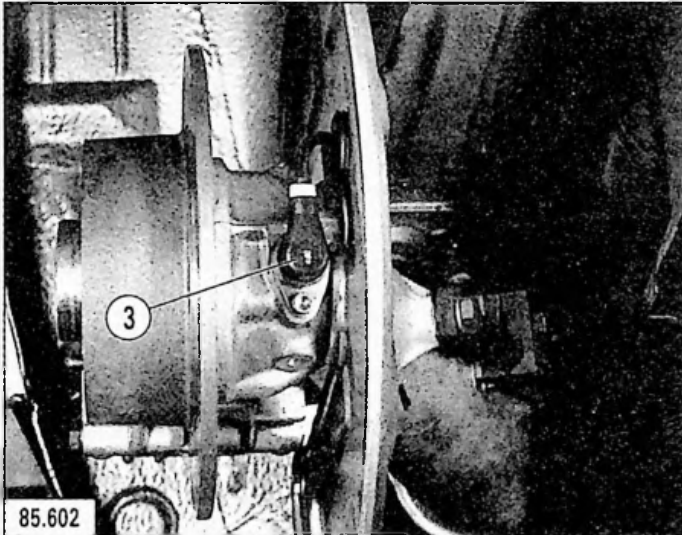

85.602

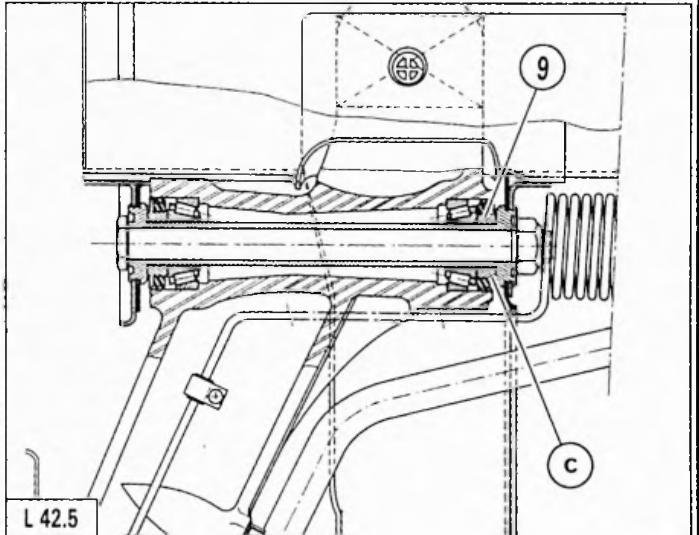

L 42.5

II

V

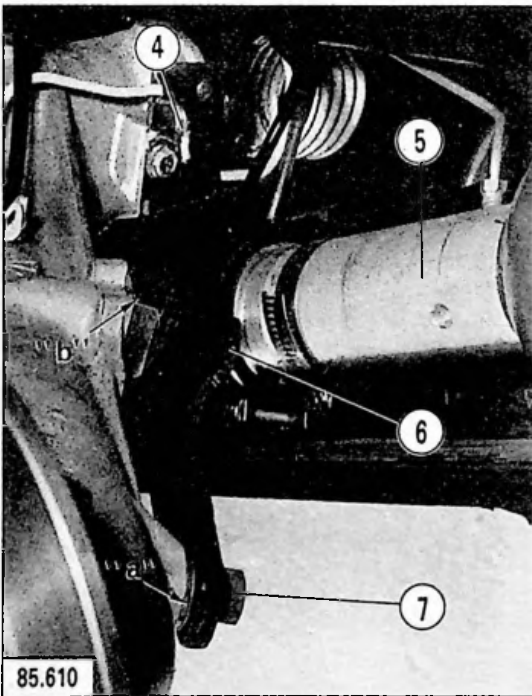

85.610

III

