



Service Manual

CASSETTE TAPE DECK

CT-F950

 **PIONEER**

2. FRONT PANEL FACILITIES

Cassette compartment illumination

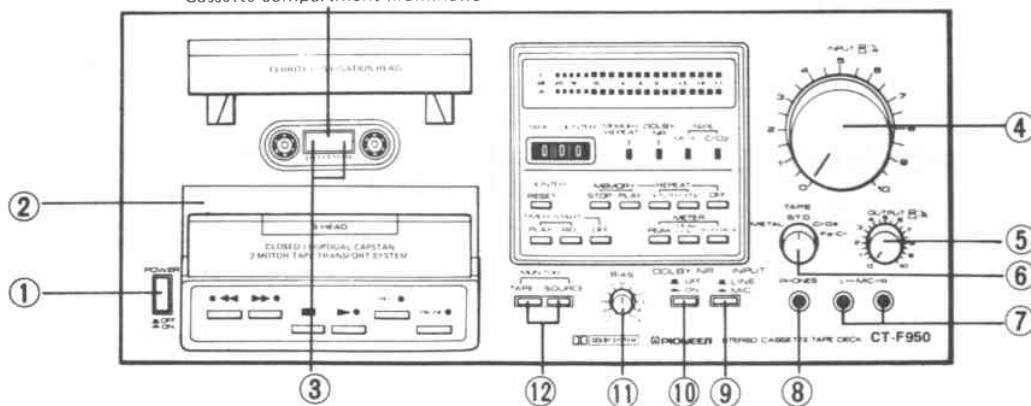

① POWER SWITCH

The power comes on when the POWER switch is depressed. The level meter and tape counter, and the cassette compartment illumination will then come on.

② DUST COVER

When you are not using the deck, always keep this cover in place to prevent dust and dirt from adhering to the head section and rotating parts.

③ REMAINING TAPE MARKER

If this marker is visible, it means that there is enough tape remaining for several minutes of recording or playback.

④ INPUT (RECORDING LEVEL) CONTROLS

Use these to adjust the level of the input signals from the MIC jacks or rear panel INPUT jacks.

Turning these controls to the right increases the level.

The controls are coupled to the left and right channels, but you can also use them to adjust the right channel (back) and the left channel (front) independently.

⑤ OUTPUT (PLAYBACK LEVEL) CONTROLS

Use these to adjust the output signal level during playback. Turning the controls to the right increases the level. The controls are coupled when turned but it is also possible to adjust the right channel (back) and the left channel (front) independently.

When playing back a reference tape (160 nwb/m), a reference playback level (0dB) is obtained with these controls set to the "6" click stop position.

⑥ TAPE SELECTOR

This selector allows the bias and equalizer characteristics to be selected during recording and the equalizer characteristics during playback in line with the type of tape you are using.

METAL: For using metal tapes

STD: For using ordinary or LH tapes

CrO₂: For using chrome tapes

Fe-Cr: For using ferrichrome tapes

⑦ MIC JACKS

These are the input jacks for microphone recording. Plug the left channel microphone into the L jack and the right channel microphone into the R jack.

⑧ HEADPHONES JACK

This is the output jack for your stereo headphones. You will be able to hear sound from signals selected by the MONITOR switches. Use this jack when you want to monitor the quality of a recording or when you want to listen to a tape privately on the CT-F950. Adjust the output level with the OUTPUT controls.

NOTES:

• Use low-impedance headphones. If you use a high-impedance model, you will not be able to obtain sufficient volume.

• You will damage the microphone if you plug it into the HEADPHONES jack by mistake.

⑨ INPUT SELECTOR SWITCH

Use this switch to select the program source which you intend to record.

LINE: Set to this position for recording a program source which is connected to the rear panel INPUT jacks.

MIC: Set to this position for recording signals from a microphone, or microphones, connected to the MIC jacks.

NOTE:

You will be able to record signals from the INPUT jacks if the LINE switch is depressed even when the microphones are plugged into the MIC jacks.

⑩ DOLBY* NR SWITCH

Set this switch to ON for recording with the built-in Dolby noise reduction system and for the playback of tapes which have been recorded using the Dolby NR system.

⑪ BIAS CONTROL

Use this control to adjust the bias in accordance with the characteristics of the tape being used. It is set so that the center (click stop) position corresponds to the standard bias.

⑫ MONITOR SWITCHES

You will be able to listen to the recorded signals (playback sound) if you depress the TAPE while you are recording a program. You will be able to listen to the signals (recording input) just before they are recorded if you depress the SOURCE. Use these switches to monitor your recording. Depress the TAPE during playback.

*Manufactured under license from Dolby Laboratories.

*Dolby and  are trademarks of Dolby Laboratories.

1. SPECIFICATION

Systems	Compact cassette, 2-channel stereo
Motors	Capstan drive; DC servo motor x 1 Reel drive; DC high torque motor x 1
Heads	Ferrite recording/ playback combination type head x 1 erasing head x 1
Fast Winding Time	Approximately 85 seconds (C-60 tape)
Wow and Flutter	No more than 0.04% (WRMS)
Frequency Response	
-20dB Recording	
Standard, LH tapes	20 to 17,000Hz (25 to 15,000Hz \pm 3dB)
Ferrichrome tape	20 to 19,000Hz (25 to 17,000Hz \pm 3dB)
Chromium dioxide tape	20 to 19,000Hz (25 to 17,000Hz \pm 3dB)
Metal tape	20 to 19,000Hz (25 to 18,000Hz \pm 3dB)
0dB Recording	
Chromium dioxide tape	20 to 11,000Hz
Metal tape	20 to 14,000Hz
Signal-to-Noise Ratio	Dolby NR OFF; More than 59dB Dolby NR ON; More than 69dB (over 5kHz)
Harmonic Distortion	No more than 1.2% (0dB)
Inputs (Sensitivity/Maximum allowable input/Impedance)	
MIC (L, R);	0.3mV/100mV/30kilohms, 6mm diam. jack (Reference MIC impedance; 250 ohms to 30 kilohms)
LINE x 2;	(60mV/25V/100 kilohms) Pin jack
Outputs (Reference level/Maximum level/Load impedance)	
LINE x 2;	(450mV/640mV/50 kilohms) Pin jack
HEADPHONES x 1;	63mV/90mV/8 ohms, 6mm diam. jack
Semiconductors	Transistors x 76 Diodes x 84, Photo interrupter x 1
Subfunctions	ICs x 13
	<ul style="list-style-type: none"> ● Dolby NR system (ON-OFF) with LED indicator lamp ● Fluorescent tube level meter (-20 to +7dB) (Peak/Peakhold/average selector) ● Fluorescent tape counter ● Bias fine adjusting control knob ● Memory stop/Memory play ● Counter repeat/End repeat ● Input selector ● Automatic tape slack canceller ● Cassette compartment illumination ● Standby mechanism with unattended recording ● Tape Selector 4 position. ● Click Stop. Output VR.

Power Requirements	AC 120V 60Hz
Power Consumption	54 watts
Dimensions	420(W) x 187(H) x 365.5(D)mm Max. 16-9/16 x 7-3/8 x 14-3/8 in.
Weight	10.1kg (22lb 4oz.)
Furnished parts	Stereo connecting cords with pin plugs x 2 Head cleaning swabs x 3 Operating instructions x 1

NOTE:
Specifications and the design subject to possible modification without notice due to improvements.

NOTES:

1. Reference Tapes: Standard & LH: DIN 45513/BLATT6 or equiv.
: CrO₂: DIN 45513/BLATT7(CrO₂) or equiv.
2. Reference Recording Level: Meter 0dB indicating level (160 nwb/m magnetic level = Philips cassette reference level)
3. Reference Signal: 333Hz
4. Wow & Flutter: ● JIS [3kHz, with acoustic compensation (weighted), rms value]
5. Frequency Response: ● Measured at -20dB level, DOLBY NR OFF, level deviation is \pm 6dB without indication.
6. Signal to Noise Ratio: ● Measured at the third harmonic distortion 3% level, weighted.
7. Sensitivity: Input level (mV) required for reference recording level with input (REC) controls set to maximum.
8. Maximum Allowable Input: While decreasing settings of input (REC) level controls and increasing level at input jacks, this is the maximum input level (mV) at the point where recording amplifier output waveform becomes clipped.
9. Reference Output Level: Playback output level when meter indicates 0dB.
10. Maximum Output Level: Playback output level with respect to reference recording level when output (PLAY) level controls are set to maximum.

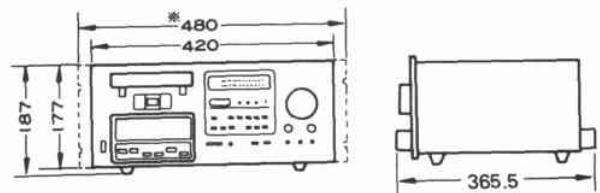

420(W) x 187(H) x 365.5(D)mm Max.

* with rackmount adaptor JA-R102

* 480(W) x 187(H) x 380(D) mm Max.

Unit: mm

3. LEVEL DIAGRAM

PLAYBACK

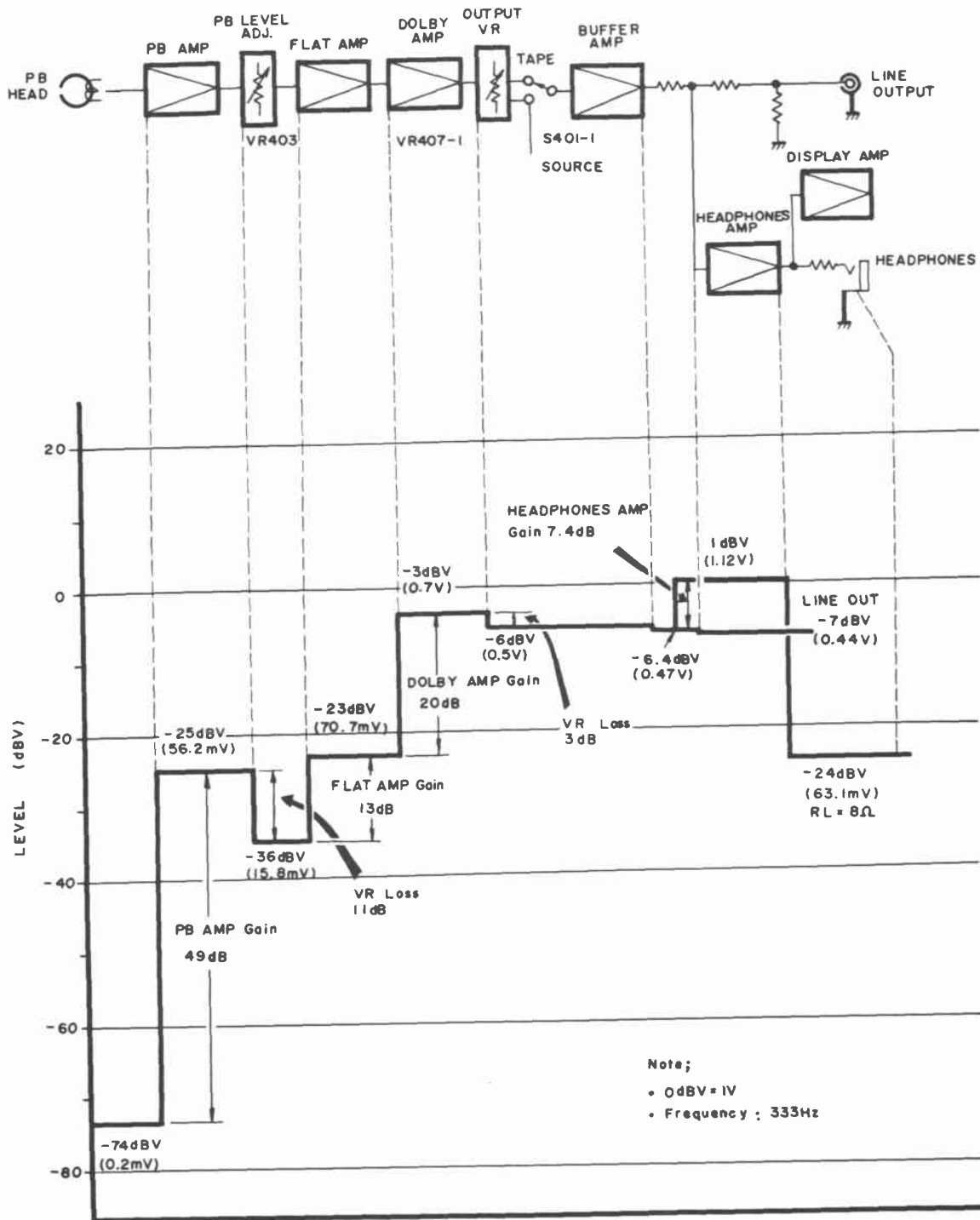

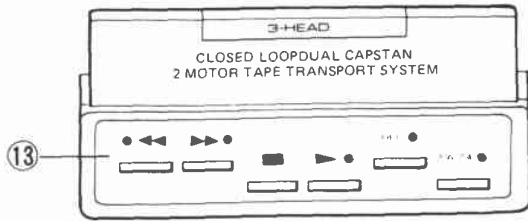

⑬ OPERATING SWITCHES

- ◀ (REW): Depress this switch to rewind the tape. (The tape will travel at high speed from right to left.)
- ▶▶ (FF): Depress this switch to send the tape forward at high speed. (The tape will travel from left to right.)
- (STOP): Depress this switch to stop the tape run and to release the operating switches.
- ▶ (PLAY): Depress this switch when playing back a tape. (The tape will travel from left to right.)
- REC: Depress this switch together with the PLAY switch for recording. This switch will not work when a cassette is not loaded or when the erasure prevention tabs of a loaded cassette have been broken off.
- PAUSE: Depress this switch to stop the tape temporarily during recording or playback. Depress it again to allow the tape to continue to travel as before.

NOTES:

- When any of the operating switches are depressed, the corresponding indicator (except STOP mode) will come on signifying that the deck is set to that respective mode.
- All the operating switches are released (OFF) to stop mode when the POWER switch is turned OFF.

⑭ COUNTER RESET BUTTON

Depress this button to reset the tape counter display to "000."

⑮ TAPE COUNTER

This indicates the position of the tape run. The counter reset to "000" when the power is switched on.

⑯ LEVEL METER

This indicates the input level during recording and the output level during playback.

By operating the METER switches, it can be made to function as a peak meter, a peak hold meter or as a level meter.

The input signal level is indicated when the MONITOR switch SOURCE has been depressed, and the playback output level is indicated when the MONITOR switch TAPE has been depressed.

⑰ DOLBY NR INDICATOR

This lights up when the DOLBY NR switch is set to ON and it indicates that a tape is being recorded or played back with the Dolby NR system.

⑱ TAPE INDICATORS

- METAL: This light comes on when the TAPE selector is set to METAL.
- CrO₂: This light comes on when the TAPE selector is set to CrO₂.

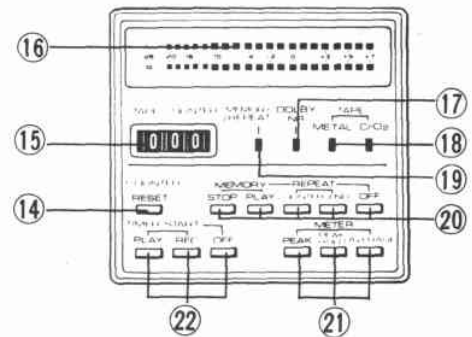

⑲ MEMORY/REPEAT INDICATOR

This indicator comes on when the MEMORY/REPEAT switches are depressed, signifying that the deck is set to the respective mode.

⑳ MEMORY/REPEAT SWITCHES

- MEMORY STOP**: Depress this switch and the tape will be rewound to that spot at which the tape counter was preset to "000" during rec/play, when the REW switch is depressed at any position you like.
- MEMORY PLAY**: Depress this switch and the tape will be rewound to that spot at which the tape counter was preset to "000" during rec/play, and playback will start from that spot, when the REW switch is depressed at any position you like.
- REPEAT COUNTER**: Depress this switch when you want to play back a tape during playback or recording from the point at which the tape counter was set to "000" up to the end of the tape.
- REPEAT END**: Depress this switch when you want to play back a tape from the beginning to the end of that tape.
- REPEAT OFF**: Depress this switch during normal tape playback or recording to release the MEMORY and REPEAT switches.

㉑ METER SWITCHES

- PEAK**: The meter functions as a peak level meter when this switch is depressed.
- PEAK HOLD**: The meter functions as a peak level meter and the highest level of the signals is indicated when this switch is depressed.
- AVERAGE**: The meter functions as a level meter when this switch is depressed.

㉒ TIMER START SWITCHES

Depress these switches when you are playing back or recording a tape with the use of a timer.

- REC**: When this switch is depressed, the deck will automatically be set to the recording mode at the preset timer time, and recording will begin. Use this switch for recording FM programs when you are out of the house or otherwise occupied.
- PLAY**: When this switch is depressed, the deck will automatically be set to the playback mode at the preset timer time, and playback will begin. Use this switch for wake-up playback instead of an alarm clock.
- OFF**: Always depress this switch when you do not intend to record or playback a tape using the timer. (This will release the REC and PLAY switches of TIMER START.)

RECORDING

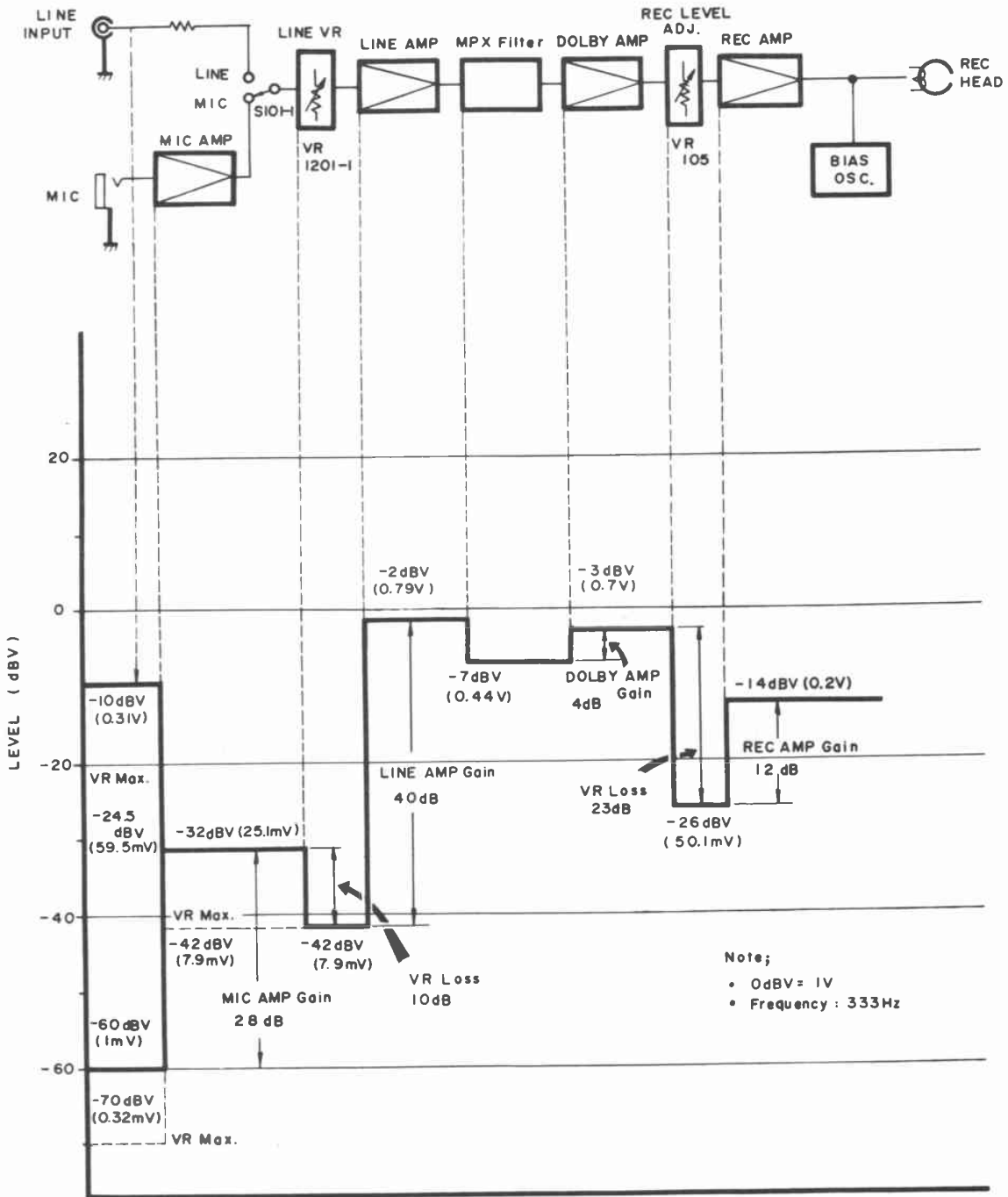

4. DISASSEMBLY

External Components

1. Remove the bonnet by undoing screws ① to ⑥.
2. Remove the front panel by undoing screws ⑦ to ⑫.
3. Remove the bottom plate by undoing screws ⑬ to ⑮.
4. The function switch assembly is mounted onto the chassis by means of rubber bushes. Remove it by gently raising it up.

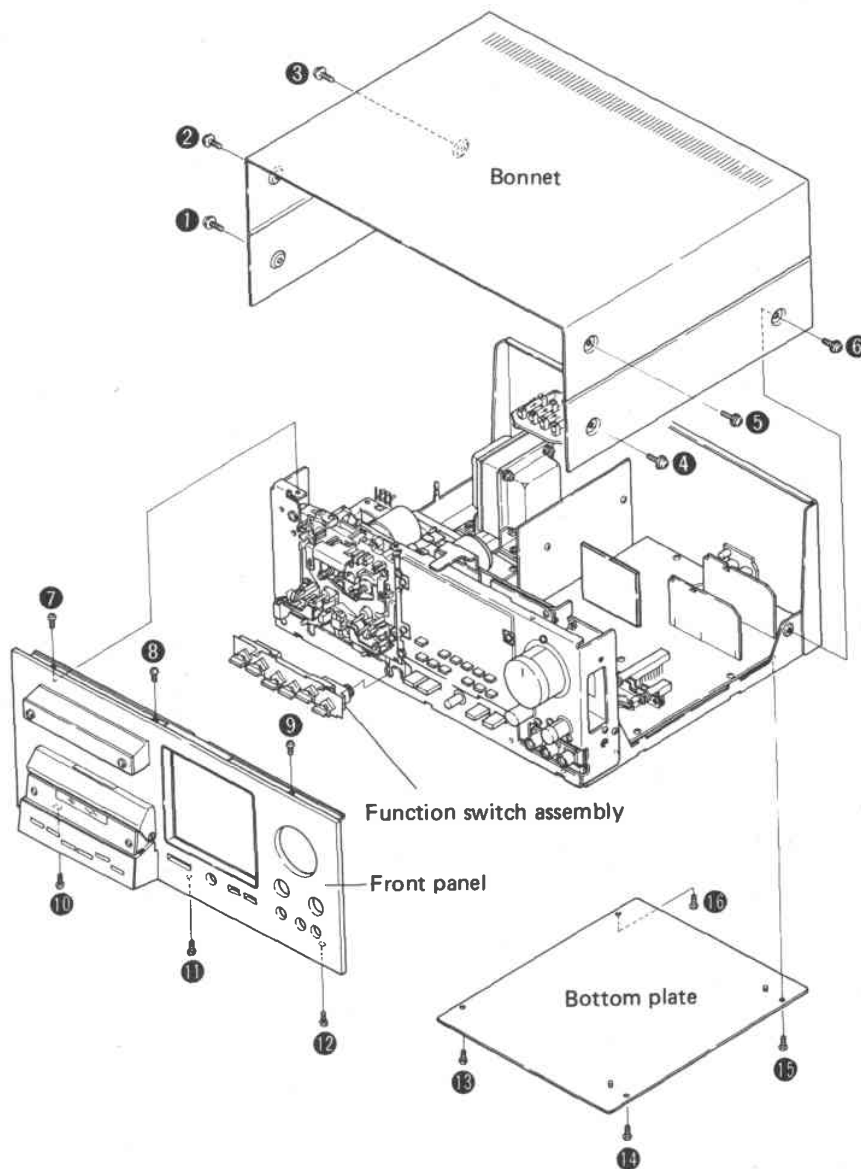

Fig. 4-1 Disassembly of exterior parts

Mechanical Assembly

When replacing a motor or a belt, be careful of the sequence of disassembly and reassembly of the various components concerned.

1. Remove the capstan motor by undoing screws ① to ③.
2. Remove solenoid A by undoing screws ④ to ⑥.
3. Remove the plunger chassis assembly by undoing screws ⑦ to ⑨.
4. Remove the sub-chassis assembly by undoing screws ⑩ to ⑭.
5. Remove the take-up motor by undoing screws ⑮ and ⑯, and remove solenoid B by undoing screws ⑰ and ⑱.

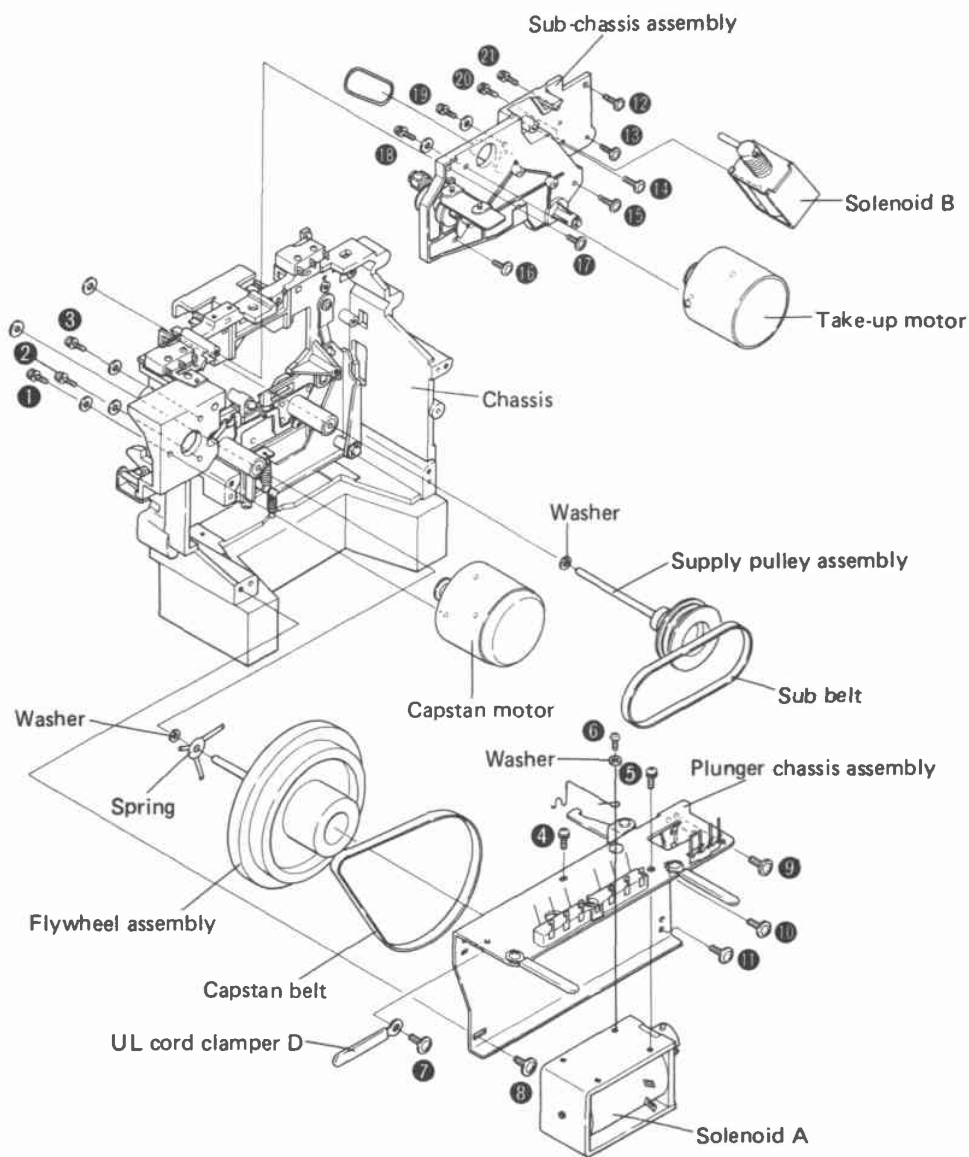

Fig. 4-5 Disassembly of mechanism assembly

Mechanical Assembly

After removing the front panel, undo screws ① to ⑥.

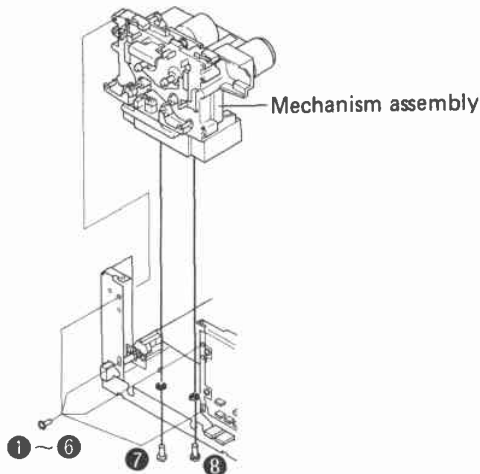

Fig. 4-2 Remove the mechanism assembly

Sub-head Assembly, Pinch-roller Arm Assembly and Pressure Arm

1. Remove the sub-head base assembly by undoing screws ① and ② and the socket-head hexagonal bolt.
2. Remove the feed side pinch-roller arm assembly by loosening the height adjuster (nut).
3. Remove the take-up side pinch-roller arm assembly by taking off E-washer ①.
4. Remove the pressure arm by taking off E-washer ②. When the pinch pressure spring is replaced with a new one, take care to ensure that the

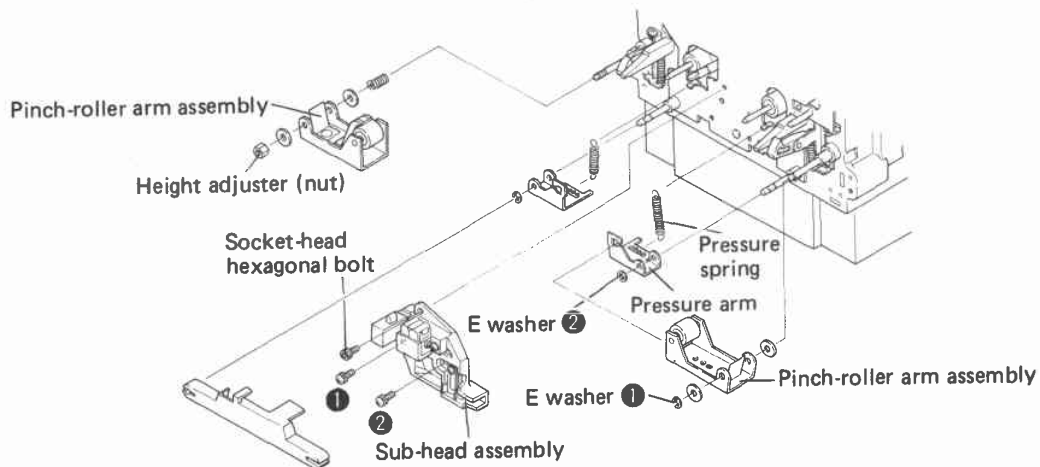

Fig. 4-4 Remove the sub-head assembly, pinch-roller arm assembly and pressure arm

new spring is properly seated. The requirements of the sub-section entitled "Pinch roller pressure adjustments" (Page 30) included in the section "Mechanical adjustments" shall be satisfied.

Fluorescent Indicator Tube

1. Remove the indicator lens assembly by undoing screws ① to ④.
2. Remove the indicator amplifier assembly by undoing screws ⑤ to ⑦.
3. The fluorescent indicator tube is mounted on the indicator assembly. Remove it by means of a soldering iron. Take great care when handling the indicator tube so as to avoid damaging it.

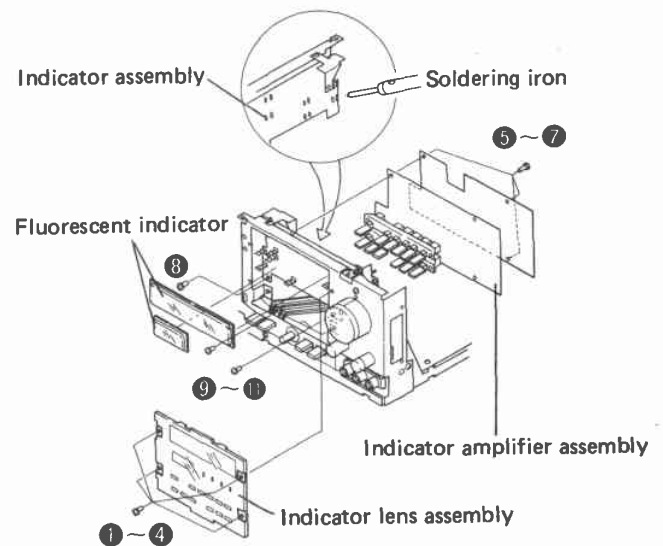
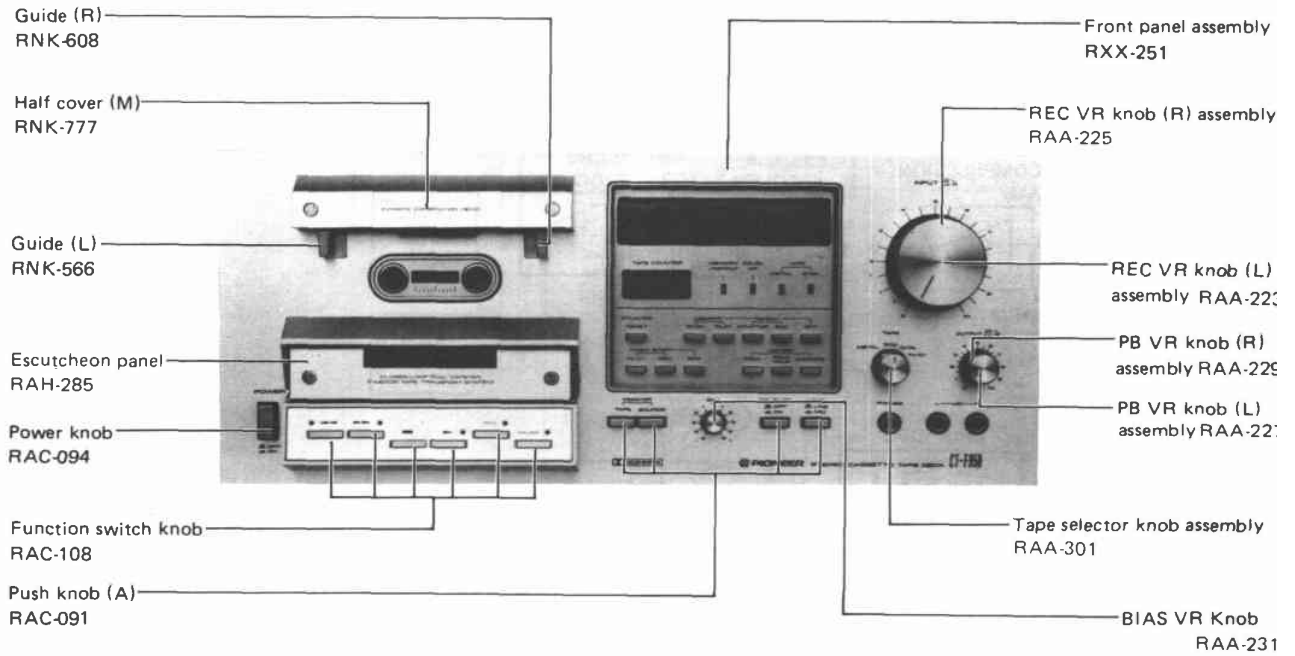

Fig. 4-3 Remove the fluorescent indicator tube

5. PARTS LOCATION

FRONT PANEL VIEW



FRONT VIEW WITH FRONT PANEL REMOVED

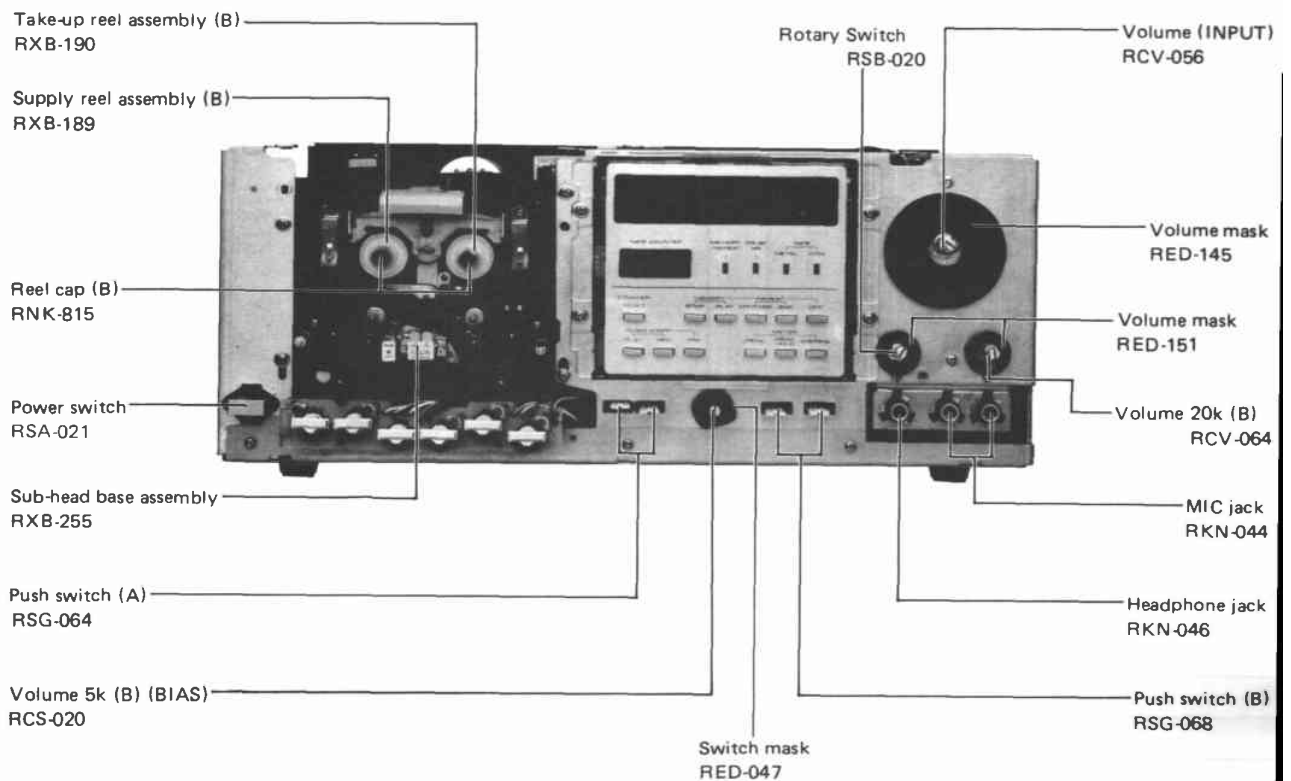

TOP VIEW WITH BONNET REMOVED

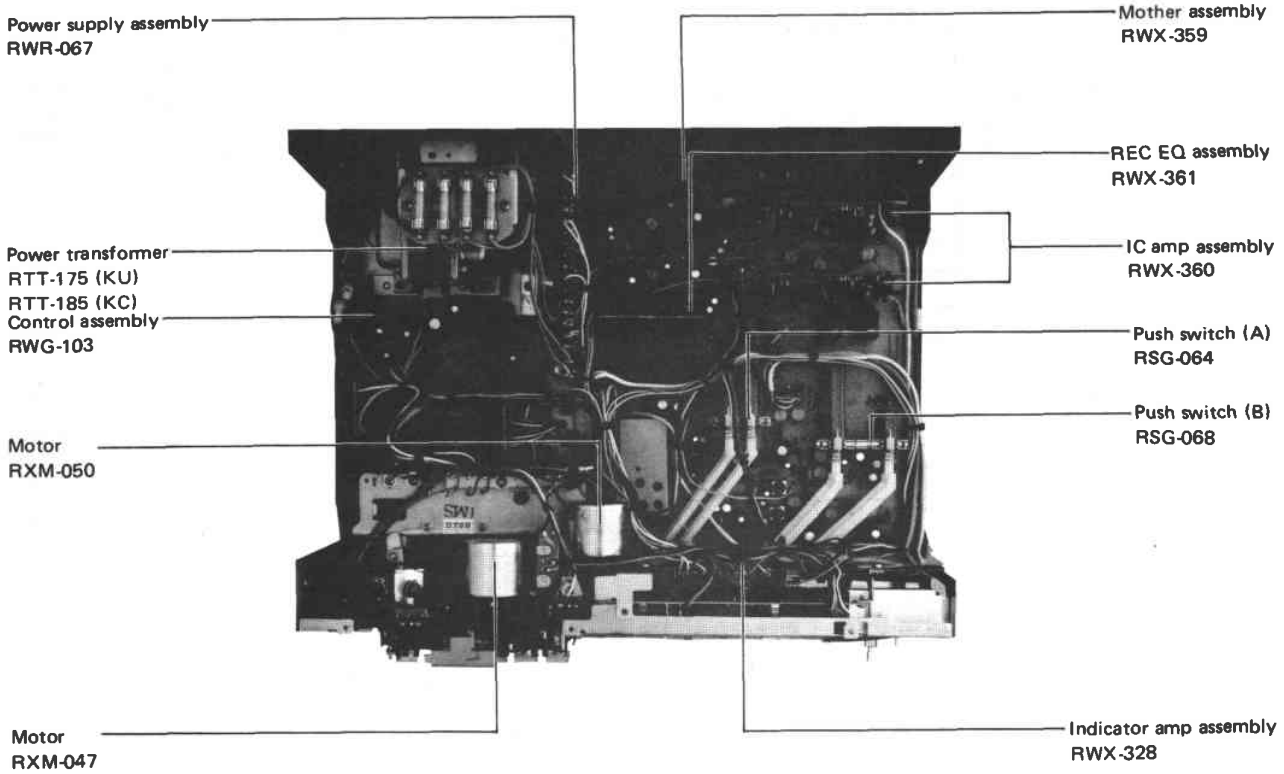

REAR PANEL VIEW

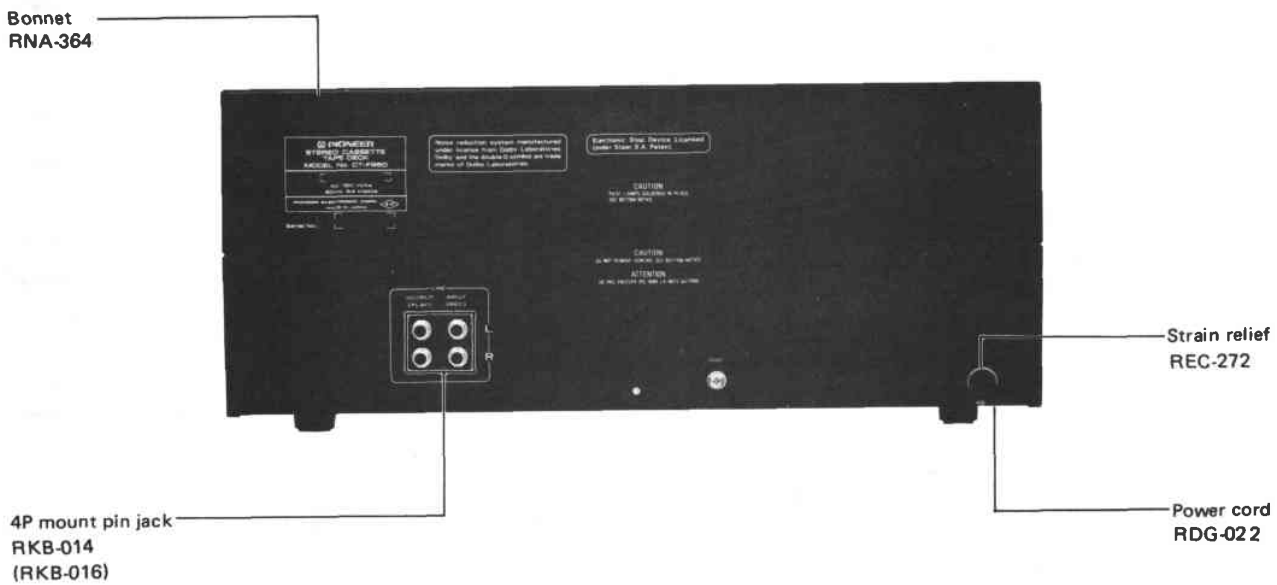

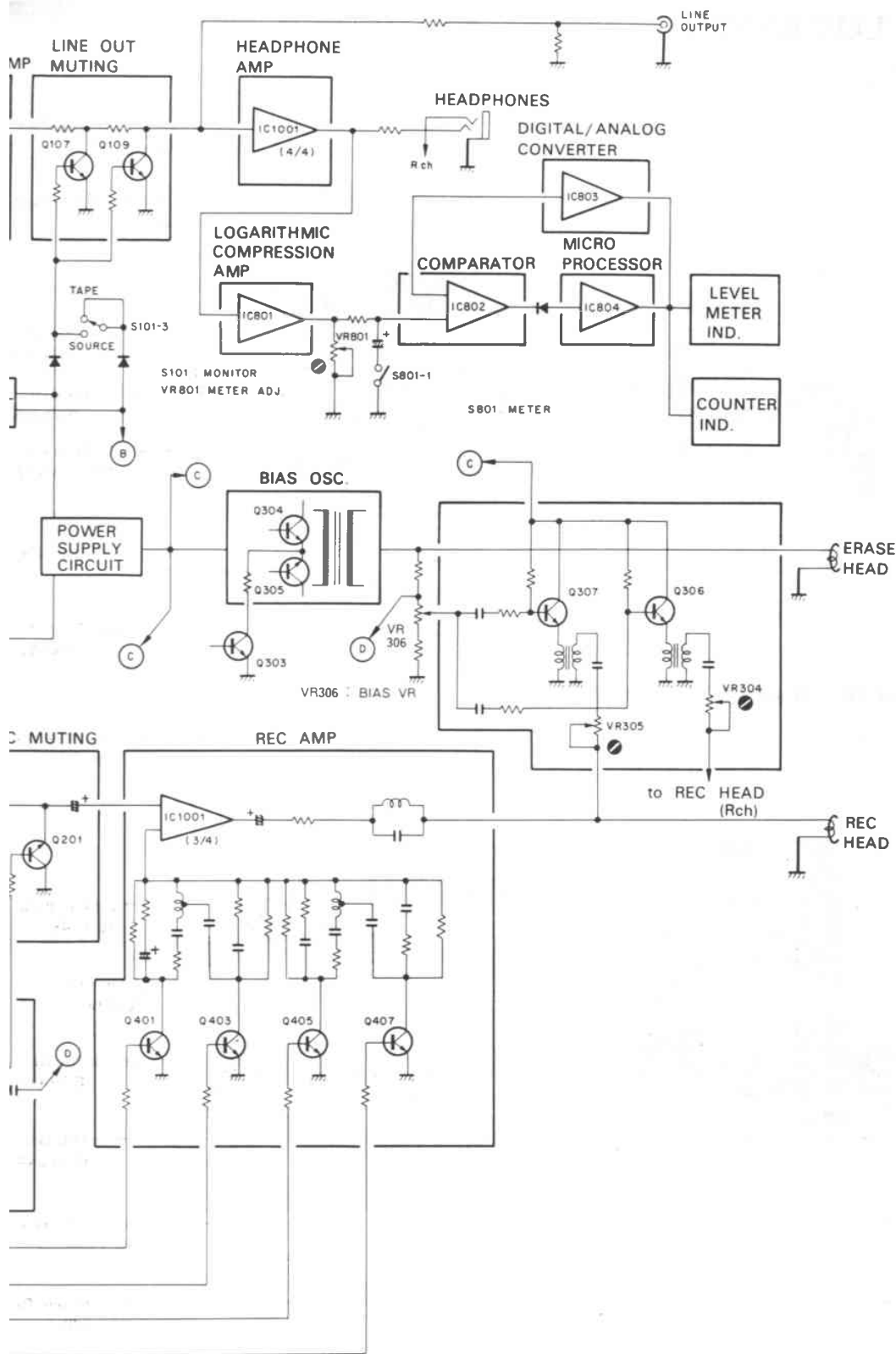

6. BLOCK DIAGRAM

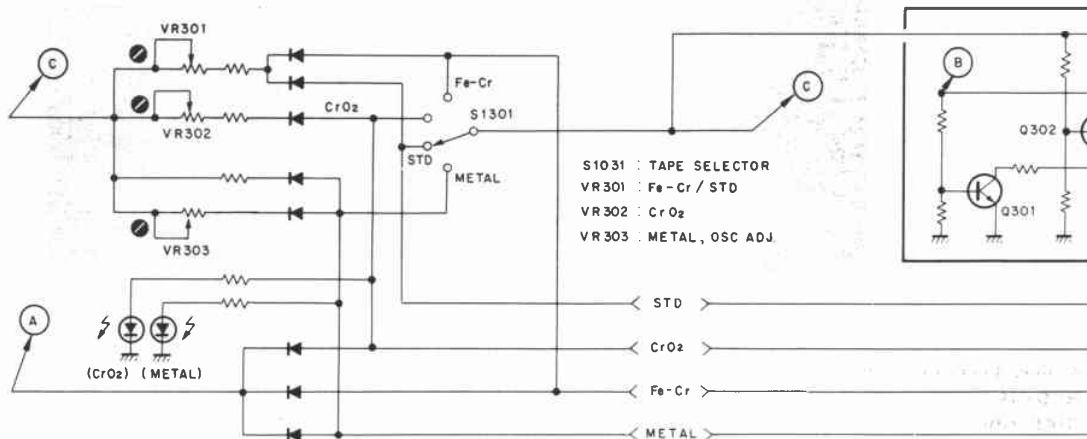
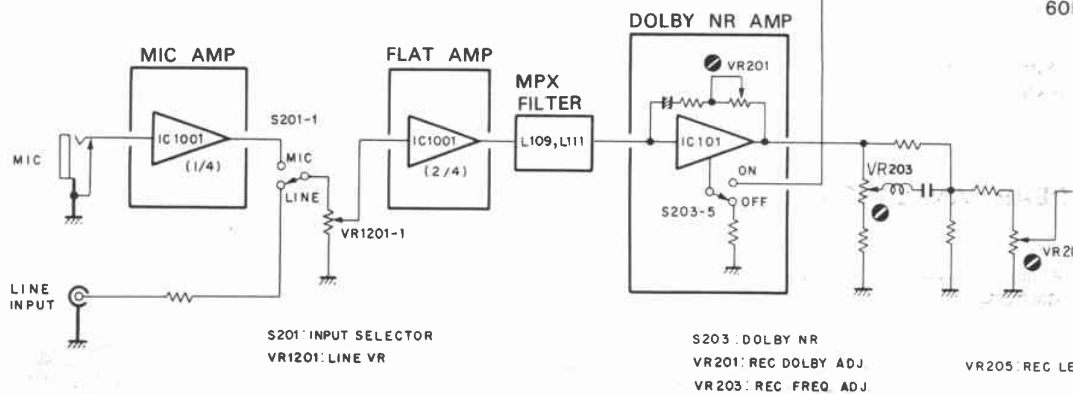
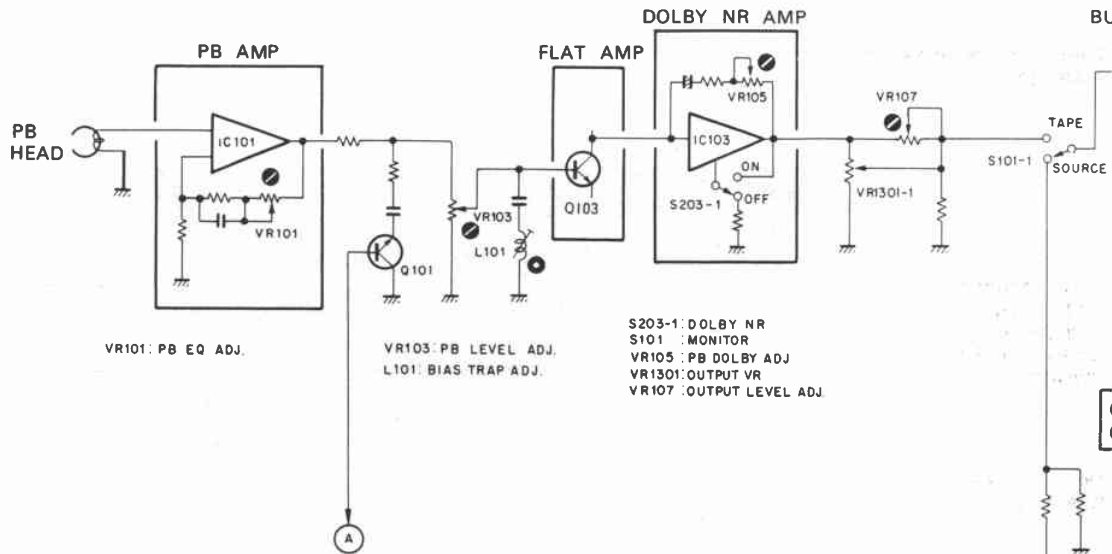

7. CIRCUIT DESCRIPTIONS

For details of the circuit of the CT-F950, refer to the block diagram on Page 13 and also the overall schematic diagram on Page 54.

7.1 RECORDING AND PLAYBACK CIRCUIT

Playback Equalizer Amplifier

The playback equalizer amplifier is an NFB type amplifier which uses a low-noise high-gain monolithic IC (AN370).

Playback Flat Amplifier (Q₁₀₃, Q₁₀₄)

The playback flat amplifier is a single transistor amplifier possessing flat frequency characteristics. It is used to amplify the output of the playback equalizer amplifier. A trap circuit is used at the input side to prevent entry of the recording bias.

Buffer Amplifier (Q₁₀₅, Q₁₀₆)

The buffer amplifier is an emitter follower type circuit which is used to take the output of the Dolby NR amplifier to the LINE OUTPUT terminals.

IC (PA4001)

The PA4001 was developed by PIONEER as a system IC for use in tape decks. It contains a microphone amplifier, headphone amplifier, flat amplifier and recording amplifier. Its block diagram is shown in Fig. 7-1.

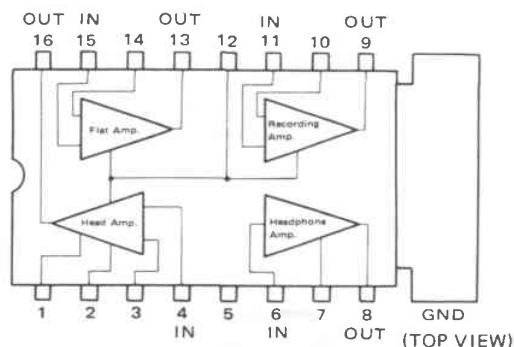

Fig. 7-1 Block diagram of PA4001

Headphone Amplifier

The headphone amplifier consists of the headphone amplifier section of the PA4001. This is a complimentary amplifier having a gain of approximately 7.4dB. The headphone output is taken off a resistive voltage divider.

Microphone Amplifier

The microphone amplifier consists of the microphone amplifier section of the PA4001. It has a gain of about 28dB.

7.2 TAPE SELECTOR CIRCUIT

The CT-F950 has been designed to use metal, CrO₂, Fe-Cr and normal tapes. The tape selector circuit (see Fig. 7-2) is switched to suitable equalizer and bias levels according to the type of tape employed. This switching, plus the tape indicator (CrO₂/METAL) switching is performed by the TAPE switch S₁₃₀₁.

Playback Equalizer Switching Circuit

The playback equalizer may be switched to either of 2 positions: 70μsec for METAL/CrO₂, Fe-Cr and 120μsec for STD. When the TAPE switch S₁₃₀₁ is in the METAL position (or CrO₂, or Fe-Cr positions), a bias current flows from D₃₀₉ (or D₃₁₁ or D₃₁₀) to Q₁₀₁ via R₁₁₇, resulting in the transistor being turned on. The C₁₁₉ and R₁₁₅ series circuit is thus connected to the playback amplifier to set up the 70μsec equalizer amplifier. When S₁₃₀₁ is switched to the STD position, Q₁₀₁ is turned off, thereby reverting to the 120μsec equalizer amplifier.

Recording Bias Generator and Bias Selector Circuit

Metal tapes require a bias current of about twice the level of the bias required for conventional STD tapes. For this reason the push-pull generator output is amplified by a bias amplifier (composed of step-up transformers L₃₀₁ and L₃₀₂ plus coupling amplifiers Q₃₀₆ and Q₃₀₇) prior to being applied to the head. The bias amplifier input may be adjusted by the front panel BIAS control. Whereas more conventional bias controls vary the B voltage of the oscillator, the system employed in the CT-F950 also varies the erasure current at the same time. Since erasure efficiency is a particular problem with metal tapes, the CT-F950 has been designed to also vary the secondary side of the oscillator transformer.

Bias switching for each type of tape is achieved through the TAPE switch S₁₃₀₁. Bias level is changed by first maintaining a constant oscillation level by R₃₂₀, and then changing the voltage by inserting resistors in parallel. The parallel connected resistors involved are R₃₂₆ and VR₃₀₃ for metal tapes, R₃₂₇ and VR₃₀₂ for CrO₂, and R₃₂₈ and VR₃₀₁ for Fe-Cr and STD.

Recording Equalizer Selector Circuit

The recording equalizer is switched to 4 separate positions (METAL, CrO₂, Fe-Cr, and STD). Transistors Q401, Q403, Q405 and Q407 are turned on

and off according to the position of the TAPE switch S1301, thereby switching the LC resonance circuit in the recording equalizer, amplifier.

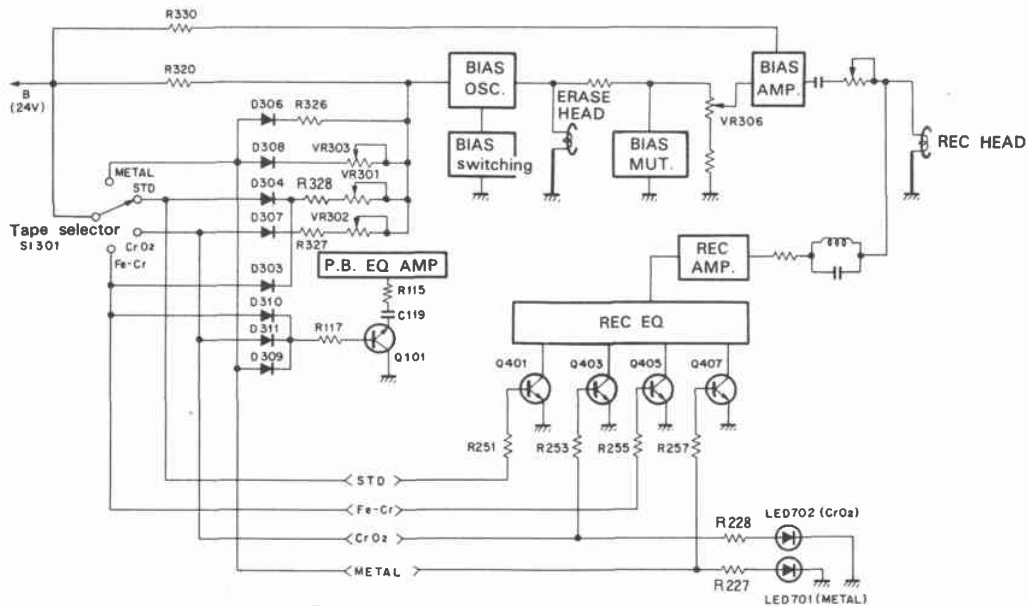

Fig. 7-2 Tape selector circuit

7.3 LEVEL METER

The level meter circuit is shown in Fig. 7-3. It consists basically of 3 ICs (IC801, IC802 and IC803) and 1 microcomputer. Levels are displayed in digital form using a fluorescent indicator tube.

1. The signal obtained from the output terminals of the headphone amplifier is converted into a IC voltage by means of a logarithmic compression amplifier. This DC voltage becomes the reference input for the comparator.
2. The comparative input to the comparator is a DC voltage obtained by passing the indication condition of the level meter through a digital/analog converter.
3. Accordingly, the comparator continually compares the reference voltage with the indication condition of the level meter, and sends signals to the microcomputer so as to maintain the comparative input (level meter indication condition) equal to the reference input.

The level meter is primarily a peak reading meter, however it is possible to use it either as a VU or PEAK HOLD meter by pressing switch S801-1 (VU) or S801-2 (PEAK HOLD).

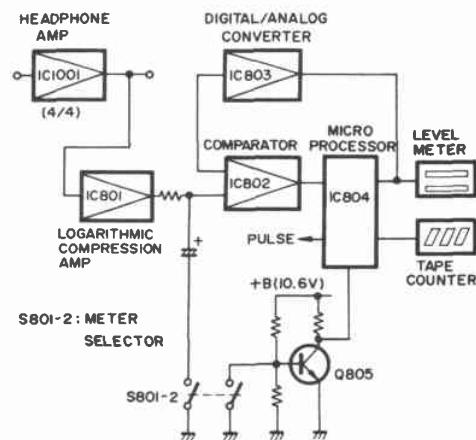

Fig. 7-3 Level meter circuit

7.4 ELECTRONIC COUNTER

The electronic counter consists of a micro-computer (IC804) and a counter type fluorescent indicator tube (Fig. 7-7). Sensing pulses emitted from the mechanical assembly undergo wave shaping at Q801 to Q803 and then enter the micro-computer (IC804). The input pulses are added and subtracted in the memory of the computer, and the resultant numerical value is displayed at the counter indicator tube.

7.5 DOLBY NR PROCESSOR CIRCUIT

Recording Mode Operation

1. Input signals are first applied to the MPX filter where the FM broadcasting station's pilot signal is employed, and where an 85kHz bias trap is employed to prevent mis-operation of the Dolby NR noise reduction system.
2. From the MPX filter, the signals are passed on to the buffer amplifier whose output is divided into 2 routes. The main signal is passed directly to the adding amplifier, while the sub-signal is passed via the side chain amplifier and clipper before being recombined with the main signal in the adding amplifier.
3. Besides being applied to the clipper, the side chain amplifier output is also passed via the voltage controlled amplifier and integrating amplifier back to the side chain amplifier input, forming a variable filter circuit.
4. In addition to the above, the side chain amplifier output is further applied to a high-pass filter and rectifier where it is converted into a DC voltage for control of the voltage controlled amplifier.
5. When the level of the signal passed through the high-pass filter is low, the rectifier output DC voltage will be almost "0", resulting in a minimum turnover frequency for the variable filter. The level of the adding amplifier output will thus be 10dB (above 5kHz) higher than the level of the main signal, thereby contraction the dynamic range.

6. The clipper produces a time lag in the signal applied to the voltage-controlled amplifier, and since it is not capable of responding to sudden level changes, no uncontrolled signals will be applied to the adding amplifier.
7. When the level of the signal passed through the high-pass filter is high, the rectifier output DC voltage will also be high, and the variable filter turnover frequency will be increased. The sub-signal level will therefore become almost "0", so there will be no contraction of the dynamic range.

Playback Mode Operation

Although each section of the Dolby NR Processor operates in the same way as during recording mode, the sub-signal is derived from the output of the adding amplifier. And since the adding amplifier is an inversion amplifier (where output phase is opposite to input phase), the sub-signal will be of opposite phase, thereby forming an NFB loop.

In Dolby NR B noise reduction systems, contraction and expansion occur within a fixed frequency range determined by the variable filter circuit. And, in order to achieve perfectly symmetrical operation, it is necessary to fix a reference level for the operational point. This is the so-called "Dolby level", below which no contraction and expansion is performed.

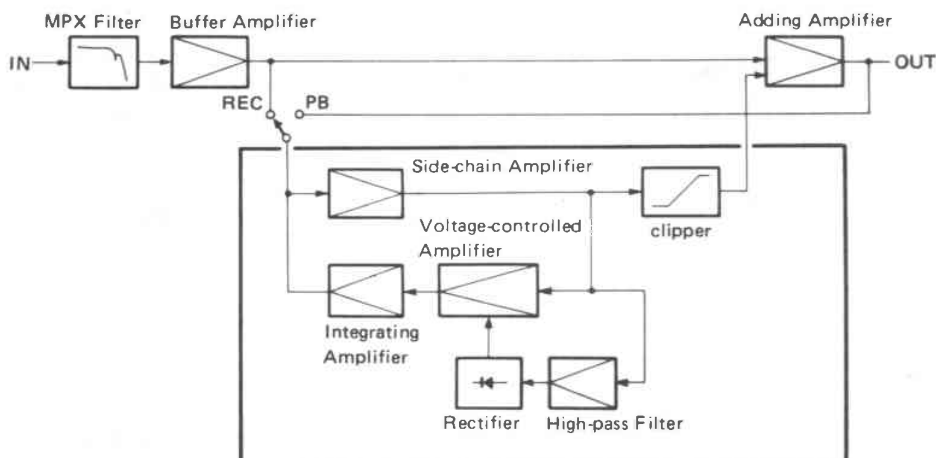

Fig. 7-4 Dolby NR processor circuit

7.6 CONTROL CIRCUIT

PLAY Operation

1. When a cassette shell is loaded, the cassette shell detection switch will go into the SHELL position and the slack elimination circuit (Described later) will commence functioning.
2. When the PLAY switch S₉₀₃ is pressed on, the voltage at Pin 17 of IC₅₀₁ will become a High level (Hereafter abbreviated to H level). Current from +B₁ will flow from the capstan motor CM to Q₅₂₂. As a result, Q₅₂₂ will become conductive, and CM will start to rotate. At the same time, current from +B₁ will flow through Q₃₂₁, the reel motor RM, R₅₅₃ and Q₅₁₇, and hence RM will also start or rotate.
3. The voltage at Pin 15 of IC₅₀₁ will also become an H level. Current from +B₁ will flow through the pinch solenoid SL₁₁₀₁, Q₅₁₂ and Q₅₁₁, hence SL₁₁₀₁ will operate and the unit will go into the PLAY mode.

REC Operation

1. When a cassette shell having erasure prevention tabs is loaded (The erasure prevention switch S₁₁₀₃ will go into the NO HOLE position), the PLAY switch S₉₀₃ and the REC switch S₉₀₄ will go on simultaneously. The operation of the pinch solenoid S₁₁₀₁ and the capstan motor CM is the same as for "PLAY operation".
2. The voltage on Pin 16 of IC₅₀₁ becomes H level. As base current flows from R₃₀₉, R₃₁₀ to Q₃₀₃, Q₃₀₃ becomes conductive, the bias oscillator circuit operates and the unit goes into the REC mode.

When a cassette shell which does not have erasure prevention tabs is loaded (S₁₁₀₃ goes into the HOLE position), Pin 5 of IC₅₀₁ will become Low level (Hereafter called L level), regardless of the position of S₉₀₄, and hence the unit will go into the REC mode.

FF, REW Operation

1. When the FF switch S₉₀₂ is turned on, Pin 22 of IC₅₀₁ will become H level. Current from +B₁ will flow through Q₅₂₁, the reel motor RM and Q₅₁₆, and thus RM will start to rotate.
2. Current from +B₁ will flow through the brake solenoid SL₁₁₀₂, R₅₄₅ and Q₅₁₃, hence SL₁₁₀₂ will operate and the brake will be removed.

3. The REW operation is basically the same as the FF operation except that the polarity of the voltage supplied to RM is reversed.

PAUSE Operation

1. As previously explained, when the unit is in either the PLAY or REC modes, current from +B₁ flows into the pinch solenoid SL₁₁₀₁, the capstan motor CM, the reel motor RM and the bias oscillator circuit.
2. If now the PAUSE switch is pushed on, Pin 15 of IC₅₀₁ will become L level. As a result, SL₁₁₀₁ will not operate and RM will not rotate (Refer to section entitled "PLAY operation"). Hence the PLAY or REC condition will be temporarily removed.

TIMER START Operation

■ PLAY Operation

1. Press the TIMER START PLAY switch S₈₀₁₋₅ on, and then put the POWER switch on using the timer etc. While C₈₁₂ is charging up, Pin 4 of IC₅₀₁ will become L level, and thus the unit will operate in the same way as if the PLAY switch S₄₀₃ were put on.
2. When the power supply voltage reaches its final value (after about 4 seconds), Pin 14 of IC₅₀₁ will become H level, and the unit will go into the PLAY mode.

■ REC/PLAY Operation

1. Press the TIMER START PLAY switch S₈₀₁₋₄ on, and then put the POWER switch on using the timer etc. While C₈₁₁ and C₈₁₂ are charging up, Pins 4 and 5 of IC₅₀₁ will become L level, and thus the unit will operate in the same way as if the PLAY switch S₉₀₃ and the REC switch S₉₀₄ were put on simultaneously.
2. In the same way as for PLAY operation, Pin 14 of IC₅₀₁ becomes H level, whereupon the unit commences REC/PLAY operation.

MEMORY STOP Operation

Press the MEMORY STOP switch on, and then press the REW switch on. When the tape counter indication reaches "999", the REW operation will stop.

1. Press the MEMORY STOP switch S₈₀₁₋₁ on, and press the REW switch S₉₀₁ on. When the tape counter indication reaches "999", a pulse will be sent from the microcomputer (IC₈₀₄).

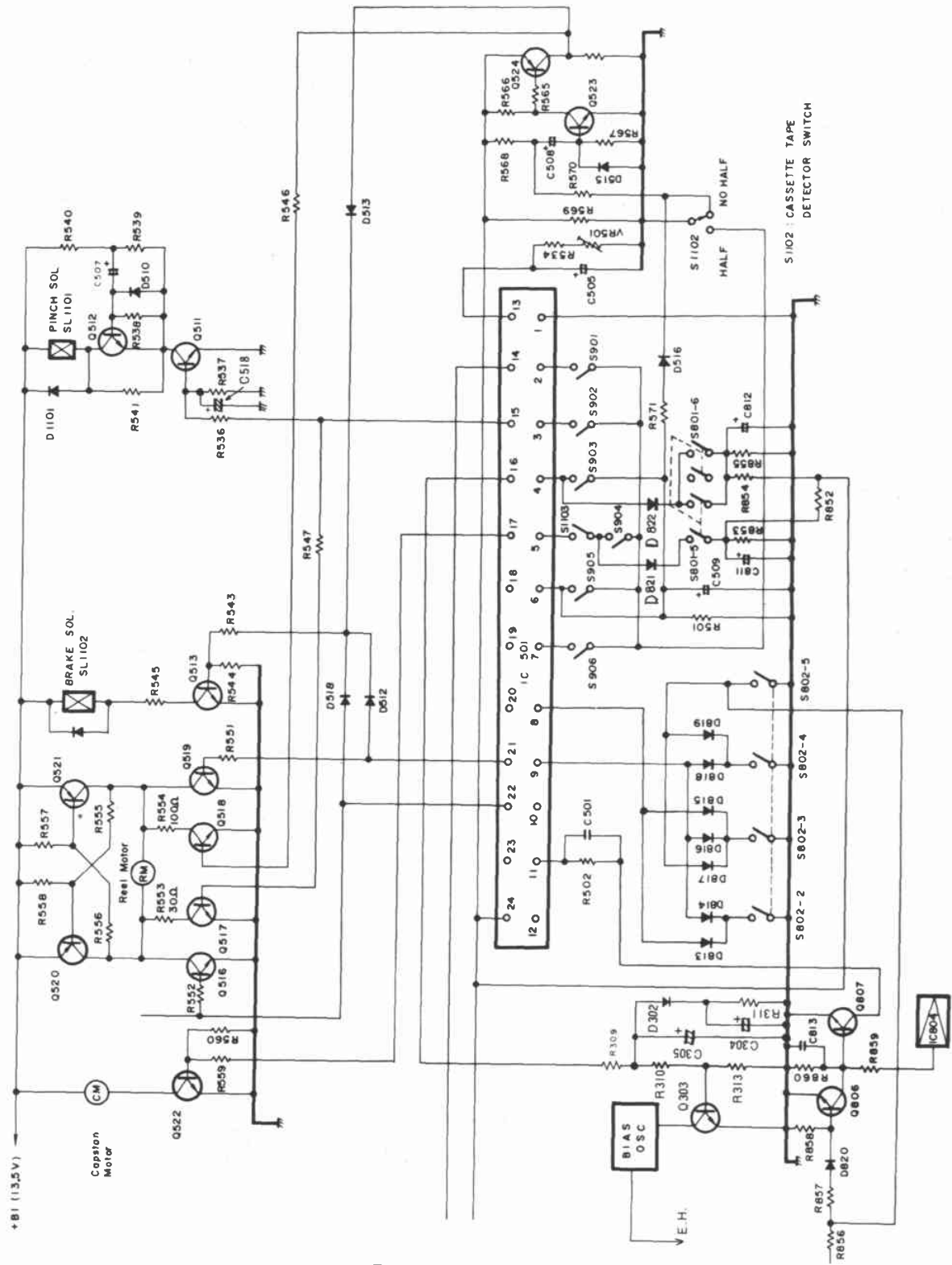

Fig. 7-5 Control circuit

Current will flow from R₈₅₉ to Q₈₀₇, thus Q₈₀₇ will be turned on, and as a result of the integral pulse, Pin 11 of IC₅₀₁ will momentarily become L level.

- When Pin 11 of IC₅₀₁ becomes L level as a result of the program within the IC, the output will go into the STOP mode, and thus the unit will cease operation.

MEMORY PLAY Operation

- Press the MEMORY PLAY switch on, and then put the REW switch on.
- When the tape counter indication reaches "999", a pulse will be sent from the microcomputer (IC₈₀₄). Current will flow from R₈₅₉ to Q₈₀₇, thus turning on Q₈₀₇, and as a result of the integral pulse, Pin 11 of IC₅₀₁ will momentarily become L level.
- When Pins 9 and 10 of IC₅₀₁ are to L level by means of the program in the IC, the unit will momentarily go into the STOP mode and then commence PLAY.

Counter Repeat

Press the REPEAT (counter) switch on. When the tape stops during PLAY or REC/PLAY (auto op), the unit will automatically go into the REW mode, and when the tape counter indication reaches "999", it will revert to PLAY.

- Press the REPEAT (COUNTER) switch S₈₀₂₋₃ on, and set Pins 8 and 9 of IC₅₀₁ to the L level. When the tape stops during PLAY or REC/PLAY, Pin 12 of IC₅₀₁ will momentarily go to the L level. When Pins 8 and 9 of IC₅₀₁ are set to the L level by means of the program in the IC, and Pin 12 goes to the L level, the unit will automatically go into the REW mode.

- When the counter indication becomes "999", a pulse will be emitted from the microcomputer (IC₈₀₄). Current will flow from R₈₅₉ to Q₈₀₇, resulting in Q₈₀₇ being turned on, while Pin 11 of IC₅₀₁ will momentarily go to the L level as a result of the integral pulse.

- If Pin 11 of IC₅₀₁ goes to the L level during the REW operation of the unit, resulting from Pin 12 going to the L level, the unit will go into the PLAY mode as a result of the program contained IC₅₀₁.

- Because of the program contained in IC₅₀₁, COUNTER REPEAT is not possible during FF or REW (Auto stop is possible).

End Repeat

Press the REPEAT (END) switch on. If the tape stops during PLYA or REC/PLAY (auto stop), the unit will automatically go into the REW mode, and when the tape has completely rewound, the unit will once again go into the PLAY mode.

- Press the REPEAT (END) switch S₈₀₂₋₂ on, and set Pins 8 and 9 of IC₅₀₁ to the L level.
- For details of the REW operation, refer to paragraph 2 "COUNTER REPEAT".
- When the tape completely rewinds, Pin 12 of IC₅₀₁ will once again momentarily go to the L level.

Pinch Solenoid Switching Circuit

This circuit is designed to protect the pinch solenoid from overheating. It operates after the PLAY switch has been pressed on, by applying a high voltage (approximately 13V) to the pinch solenoid for a period of about 0.5 seconds, in order to increase its attractive force, and then reducing the voltage to about 6V after the solenoid has operated (Fig. 7-6).

- When the PLAY switch S₉₀₃ is pressed on, Q₅₁₁ becomes conductive, the pinch solenoid SL₁₁₀₁ operates and the unit goes into the PLAY mode (Refer to section entitled "PLAY mode").

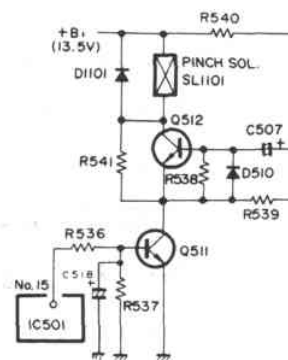

Fig. 7-6 Pinch solenoid switching circuit

2. Current will flow from +B through R_{540} , C_{507} and Q_{512} . A voltage approximately equal to the +B voltage (approximately 13V) will be applied to the pinch solenoid SL_{1101} until Q_{512} becomes fully conductive.
3. When C_{507} becomes fully charged (after an interval of about 0.5 seconds), Q_{512} will be reduced by R_{541} to the minimum value (approximately 6V) necessary to hold the plunger in position.
4. If Pin 12 of IC_{501} goes once again to the L level during the REW operation of the unit, resulting from Pin 12 going to the L level, the unit will go into the PLAY mode as a result of the program contained in IC_{501} .
5. Because of the program contained in IC_{501} , END REPEAT is not possible during FF or REW (Auto stop is possible).

Auto Stop Circuit

This circuit is used to automatically release the mechanism in the event that the tape stops during PLAY, REC, FF or REW. It employs a photo-interrupter type switch linked to the take-up reel by means of a belt, in order to detect the running of the tape (Fig. 7-7).

1. When the tape is running, pulse signals emitted from the photo-interrupter (TLP507) and hence Q_{801} , Q_{802} , Q_{803} , Q_{504} and Q_{503} switch on and off continuously. At the same time, C_{503} will charge and discharge repeatedly. While Q_{503} is turning on and off, the potential of point A will be relatively low, and thus Q_{501} will turn off.
2. When the tape stops running, pulse signals from the photo interrupter lamp will disappear, thus Q_{503} will go off. When this happens, C_{503} will charge up. The potential of point A will start to rise, and Q_{502} and Q_{501} will be turned on. Consequently, Pin 12 of IC_{501} become L level, and the unit will go into STOP mode.
3. When either the POWER switch is turned and off, or the PAUSE button is pressed, H level will be applied to the base of Q_{503} from D_{503} and D_{504} and thus the potential at point A will not rise. Consequently, the unit will go into the STOP mode.

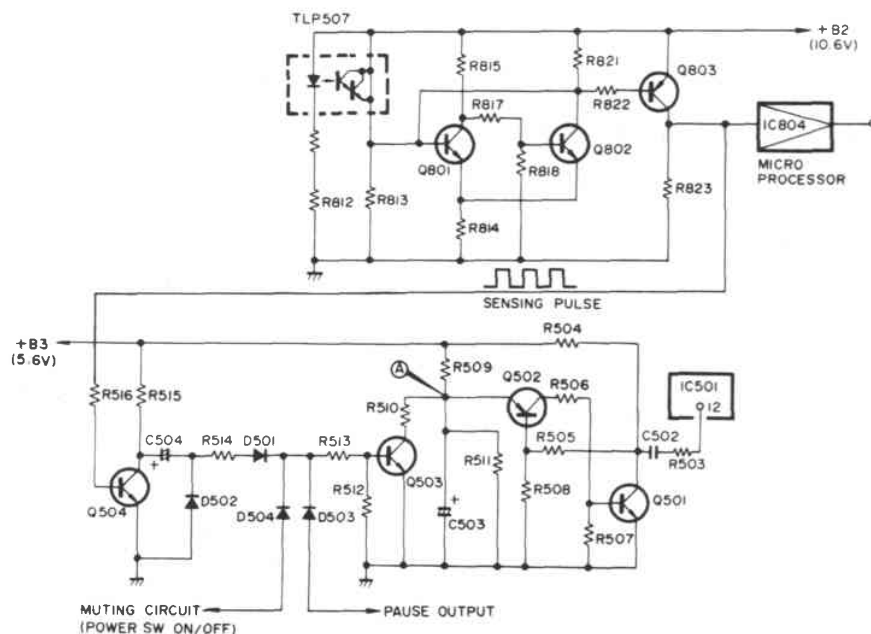

Fig. 7-7 Auto stop circuit

Tape Slack Elimination Circuit

The CT-F950 employs a closed loop capstan to provide constant speed drive for the tape. If slackness appears in the tape during PLAY, it will be impossible to obtain the necessary loop tension, and thus the normal tape head contact will be lost. The tape slack elimination circuit is designed to take up any slack when a cassette tape is loaded, by causing the supply reel to rotate in the REW direction (Fig. 7-8).

1. When a cassette shell is loaded, the cassette tape switch S1102 will go into the SHELL position. As a result, current will flow from +B3 through R568, C508 and Q523, and thus Q523 will be turned on.
2. When Q524 becomes conductive, current will flow from +B3 through Q524, D513, R543 and Q513, and thus Q513 will become conductive. Accordingly, current will flow from +B1 through the brake solenoid SL1101, R545 and Q513, and thus SL1101 will operate (Brake will be removed).
3. At the same time, current from +B3 will flow through Q524, R546 and Q518, and as a result Q518 will be turned on.

4. When Q518 is turned on, current from +B1 will flow through Q520, R555, R554 and Q518 and hence Q520 will become conductive. When Q520 and Q528 become conductive, current will flow from +B1 through Q520, the reel motor RM, R554 and Q518. As a result, RM will rotate in the reverse direction and take up the slack. The time required to take up any slack will be determined by the charging time of C508 (approximately 0.5 seconds), and the rotational torque of RM will be determined by the value of R554.
5. Muting when the unit is switched from STOP to REC is basically the same as that described in Paragraphs 1 to 3. Pin 16 of IC501 will become H level, and hence current will flow through R522 to Q505. When Q505 becomes conductive, Q506, Q507 and Q101 will be turned off, and thus the muting condition will be removed from the recording amplifier.

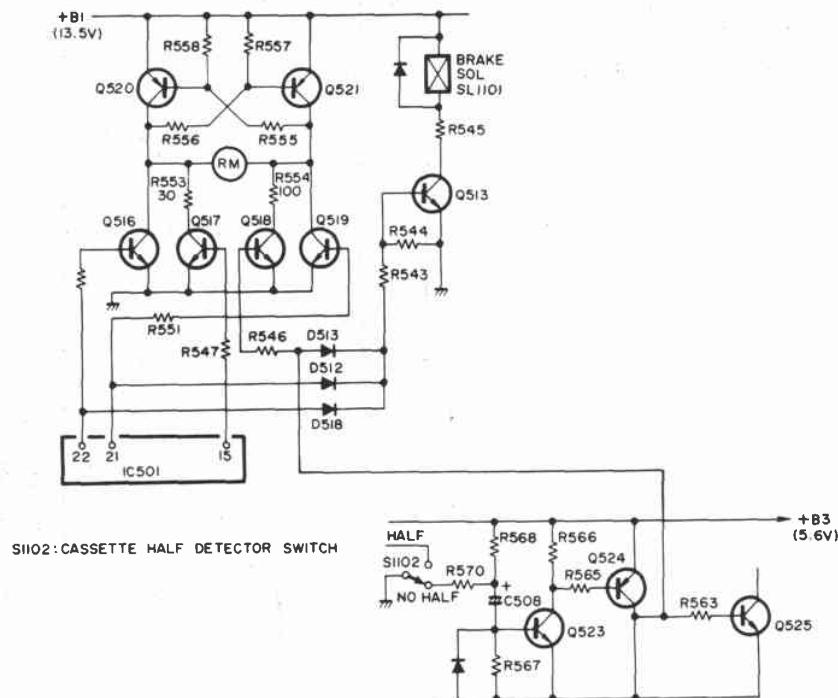
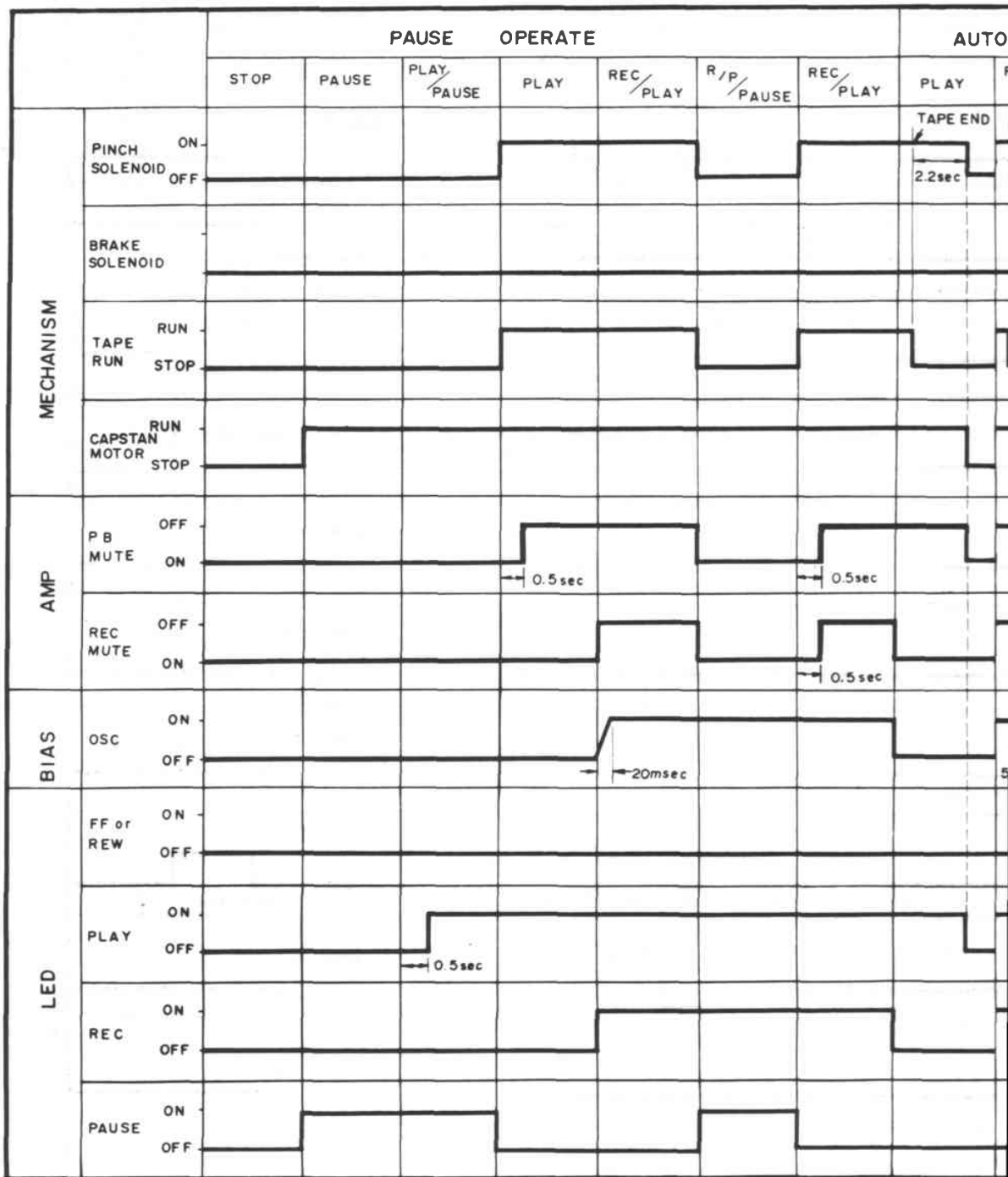
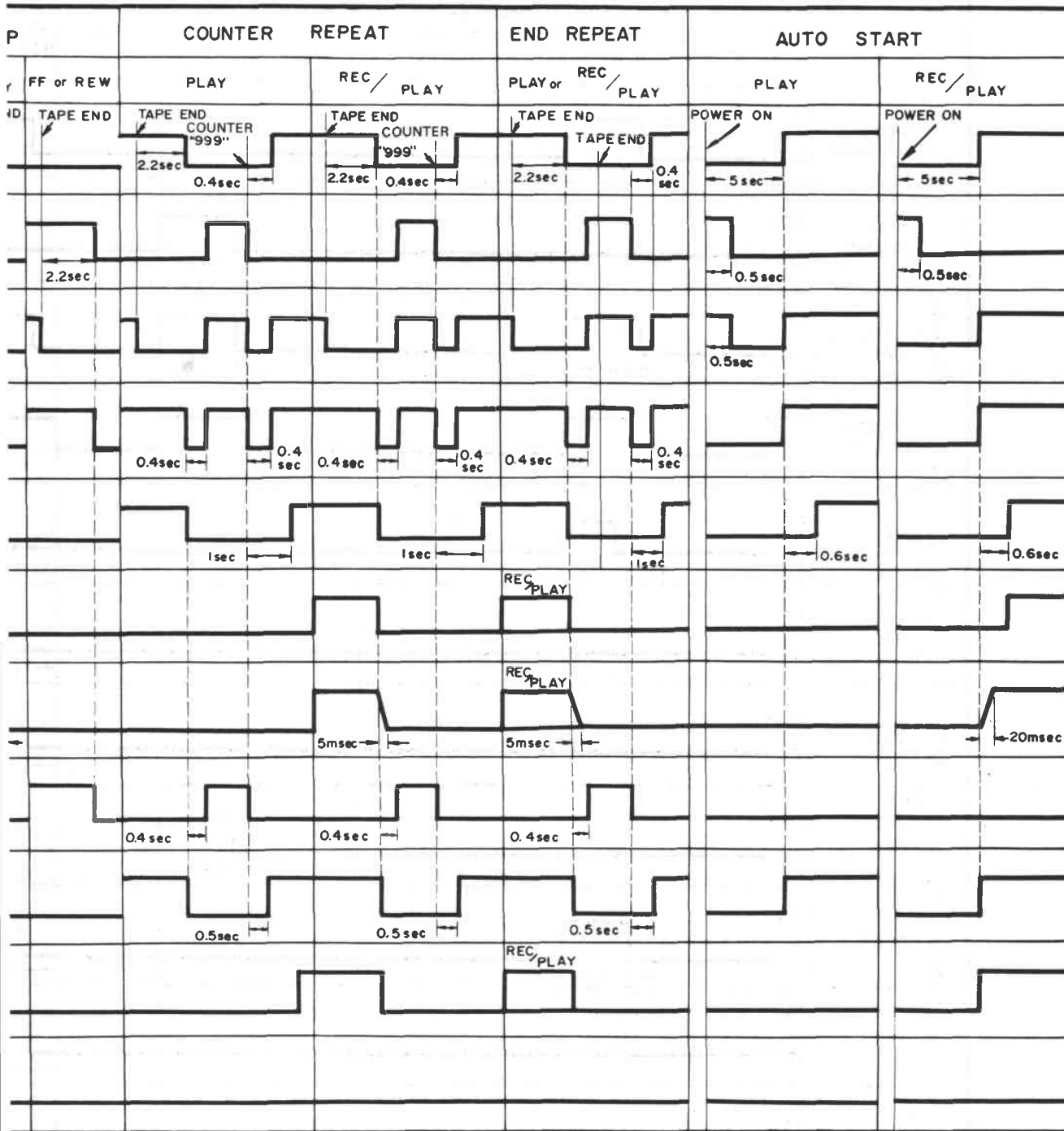
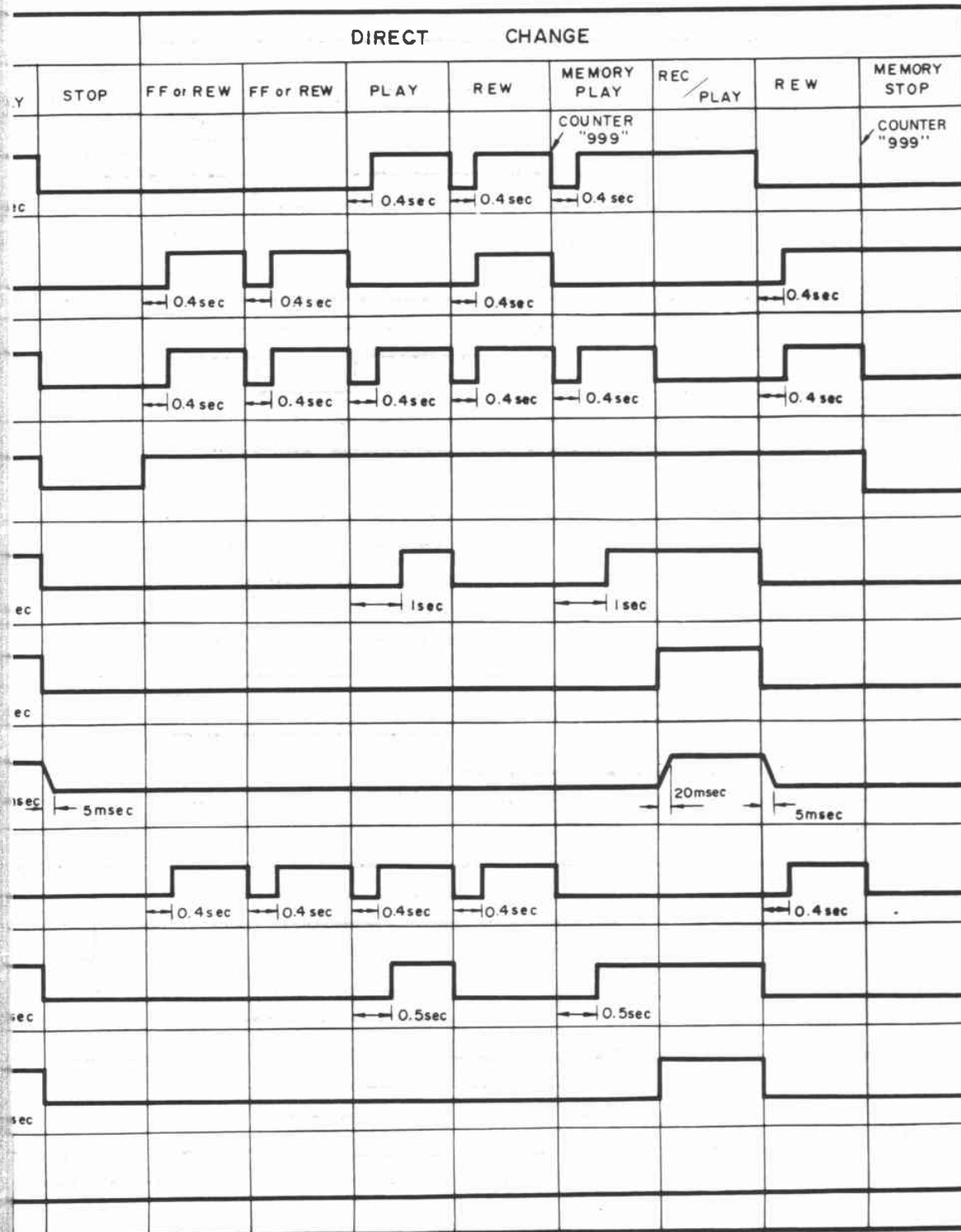

Fig. 7-8 Tape slack elimination circuit

Timing Chart 2







Timing Chart 1

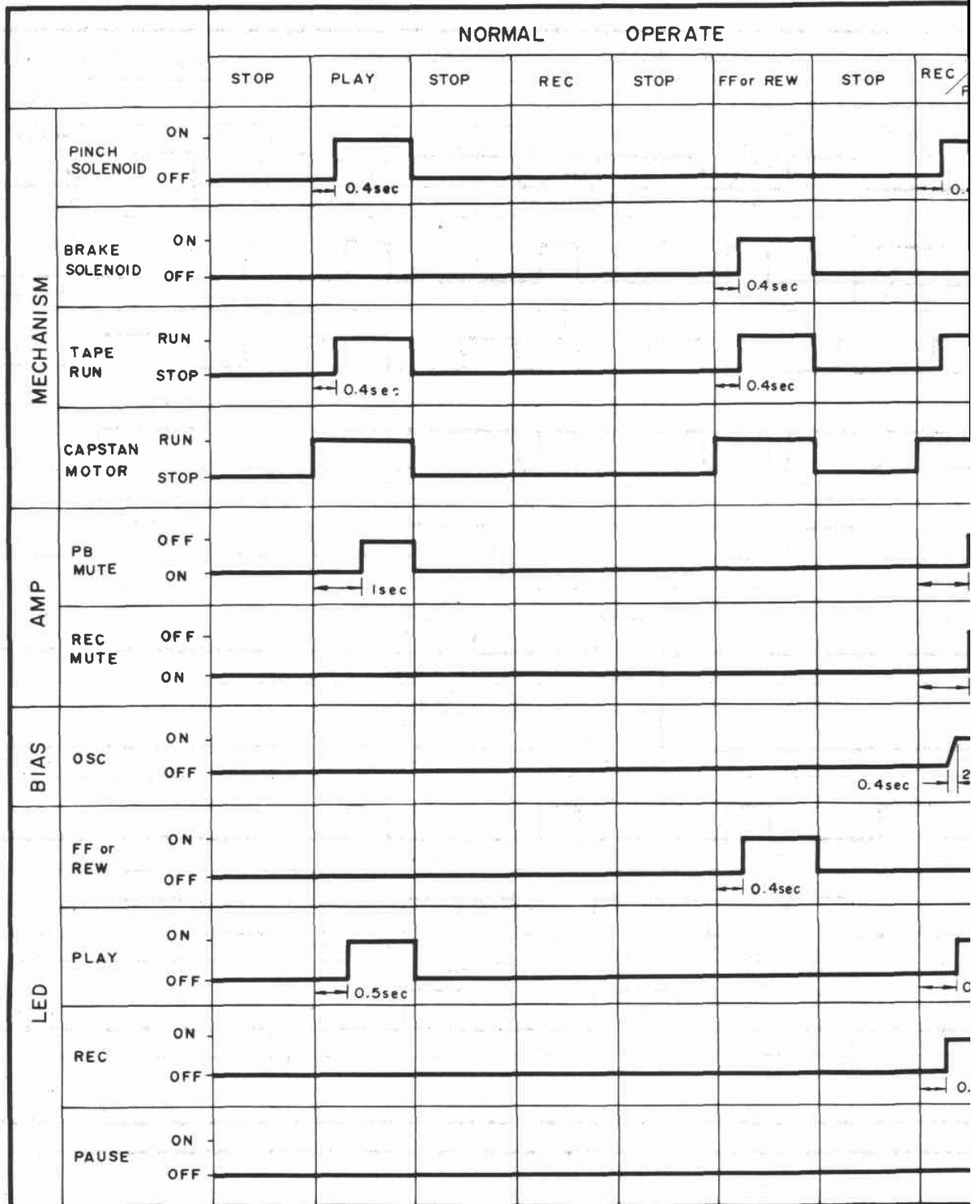

7.7 MUTING CIRCUIT

Muting When the Power Switch is Pressed On and Off

This circuit is designed to eliminate noise (e.g. click noise) when the POWER switch is pressed on or off (Fig. 7-9).

■ When Power Switch is Pressed On

1. When the POWER switch is pressed on, the emitter voltage of Q₆₀₁ will immediately rise to approximately 5.6V. Because current does not flow into C₆₀₃, the voltage across its terminals will be 0V. Consequently, in the Schmitt trigger comprising Q₆₀₂ and Q₆₀₃, Q₆₀₂ will be turned off and Q₆₀₃ will be turned on. Also, Q₅₀₄ will be turned off and Q₅₀₅ will be turned on, and thus the 5.6V source will produce a current flow through D₄₀₁ into Q₁₀₇ and Q₁₀₉. As a result, Q₁₀₇ and Q₁₀₉ will become conductive, thus short circuiting the LINE OUTPUT.
2. Meanwhile, C₆₀₇ and C₆₁₅ rapidly charge up. When C₆₀₈ charges up, the base potential of Q₆₀₈ will become -6V, and hence Q₆₀₈ will be turned off.

Consequently, the voltage across the terminals

of ZD₆₀₃ will become approximately 6V. This voltage will cause current to flow through R₆₁₁ and charge up C₆₀₃. When the voltage across C₆₀₃ reaches the reversing level of the muting circuit (Approximately 4 seconds after the POWER switch has been pressed on), Q₆₀₂ will turn on and Q₆₀₃ will turn off. Because Q₆₀₄ will be turned on, and Q₆₀₅, Q₁₀₇ and Q₁₀₉ will be turned off, the LINE OUTPUT muting condition will be removed.

■ When the Power Switch is Pressed Off

1. When the power switch is pressed off, the charges stored on C₆₀₇ and C₆₁₅ will rapidly decay. Consequently, the charge on C₆₀₃ will flow through D₆₀₃ and R₆₀₃ into the base of Q₆₁₄. When Q₆₀₈ becomes conductive, the charge on C₆₀₃ will rapidly decay.
2. Consequently, Q₆₀₂ will now be turned on, and Q₆₀₄ turned off. Q₆₀₄ will be turned off, and Q₆₀₅, Q₁₀₇ and Q₁₀₉ turned on, hence the LINE OUTPUT will be muted. After the POWER switch has been pressed off, the power supply for the unit will be charged on C₆₀₂.

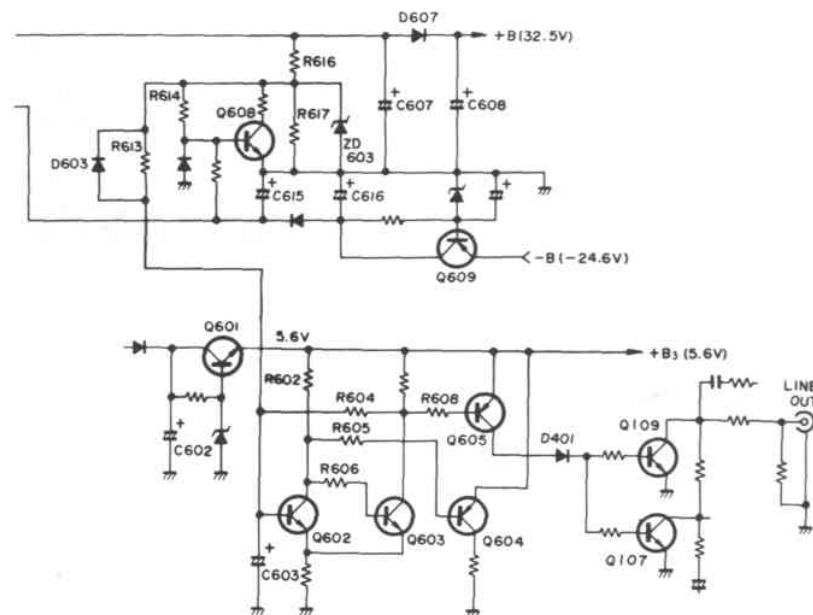

Fig. 7-9 Muting circuit 1

Muting during FF, REW and STOP

This circuit is designed to eliminate noise (e.g. motor noise), during FF, REW or STOP (Fig. 7-10).

1. During FF, REW or STOP, Pin 20 of IC₅₀₁ will become H level, and hence base current will flow into Q₅₀₈.
2. When Q₅₁₈ becomes conductive, Q₅₀₉ and Q₅₁₀ will also become conductive. Current from +B₃ will flow through Q₅₁₀, Q₄₀₂, S₁₀₁₋₃, R₁₇₅, R₁₇₇, Q₁₀₇ and Q₁₀₉. Accordingly, Q₄₀₇ and Q₄₀₉ will become conductive, and the LINE OUTPUT will be muted.
3. At the same time, current will flow from +B₃ through Q₅₁₀, D₅₁₇, R₂₄₃ and Q₂₀₁. Q₂₀₁ will thus become conductive and mute the recording amplifier.
4. When the MONITOR switch S₄₀₁₋₃ is in the SOURCE position, the LINE OUTPUT will not muted.

Muting During Changeover from Stop to Play (or REC)

This circuit is designed to prevent switching noise when the PLAY or REC switches are operated (Fig. 7-10).

1. When the unit is in the STOP condition, Q₁₀₇, Q₁₀₉ and Q₂₀₁ will be conductive, and hence the LINE OUTPUT and the recording amplifier will be muted. Also, C₅₀₆ will be charged (Refer to previous section entitled "Muting when unit is in STOP condition").
2. When the PLAY switch is pressed on, Pin 20 of IC₅₀₁ will become L level, and hence current will not flow through Q₅₀₈.
3. When Q₅₀₈ becomes non-conductive, the charge on C₅₀₆ will decay via R₅₂₉. During the interval that C₅₀₆ is discharging (approximately 1 second), Q₅₀₉, Q₅₁₀, Q₁₀₇ and Q₁₀₉ will become conductive. After about 1 second, the unit will go into the PLAY condition, and thus switching noise will be muted.
4. When the unit is in the PLAY condition, current will flow from +B₃ through R₅₂₃, R₅₂₄ and Q₅₀₆, and thus Q₅₀₆ and Q₅₀₇ will go on. Consequently, current from +B₃ will flow through Q₅₀₇, D₅₀₈, R₂₄₃ and Q₂₀₁, and hence the recording amplifier will remain muted.

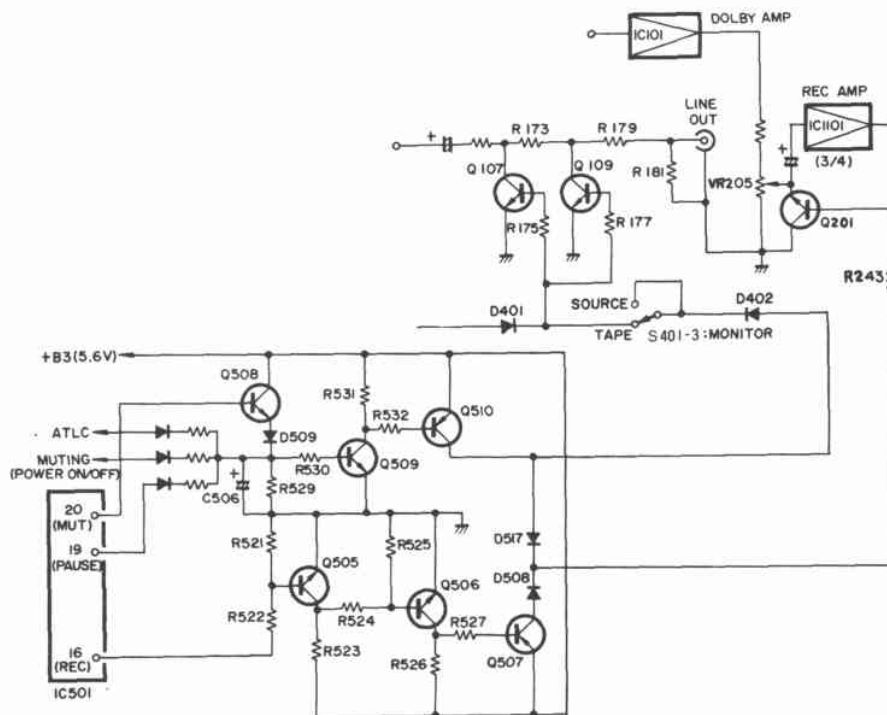

Fig. 7-10 Muting circuit 2

5. Muting when the unit is switched from STOP to REC is basically the same as that described in Paragraphs 1 to 3. Pin 16 of IC₅₀₁ will become H level, and hence current will flow through R₅₂₂ to Q₅₀₅. When Q₅₀₅ becomes conductive, Q₅₀₆, Q₅₀₇ and Q₂₀₁ will be turned off, and thus the muting condition will be removed from the recording amplifier.

Bias Muting Circuit

During recording, the bias signal is sometimes recorded due to the increase in the relative speed of the tape and head during the on/off switching of the PAUSE or release of the recording controls. The recorded bias signal can be heard as a "click" noise when the tape is played back at its fixed speed; the purpose of this circuit is to suppress this noise.

1. During REC/PLAY operation (when the REC and PLAY switches are turned on simultaneously), the No. 16 pin on IC₅₀₁ reaches H level, and because the Q₃₀₃ receives bias and comes on, the oscillator circuit operates.

2. When the PAUSE switch is turned on, the No. 19 pin of IC₅₀₁ reaches H level, and the bias comes on through the D₅₀₇ - R₅₂₀ - R₅₃₀ route to send bias current to Q₅₀₉.

3. With Q₅₀₉ on, Q₅₁₀ is also turned on, and +B takes the D₅₁₇ - R₃₀₁ route to turn on Q₃₀₁.

4. With Q₃₀₁ turned on, C₃₀₃ and R₃₀₃ follow a fixed time constant and turn on Q₃₀₂ by reducing the emmitter voltage.

5. When Q₃₀₂ comes on, the bias current flows through the condenser and is grounded. Bias current is supplied to neither the base of Q₃₀₆, Q₃₀₇ nor to the record head.

6. When the PAUSE switch is set to OFF, the PAUSE operation is halted and recording resumes. However, even if the No. 19 pin on IC₅₀₁ reaches L level, since the discharge time for C₃₀₃ (determined by the C₃₀₃ and R₃₀₈ time constants) only turns on Q₃₀₂, there is no bias supplied to the record head.

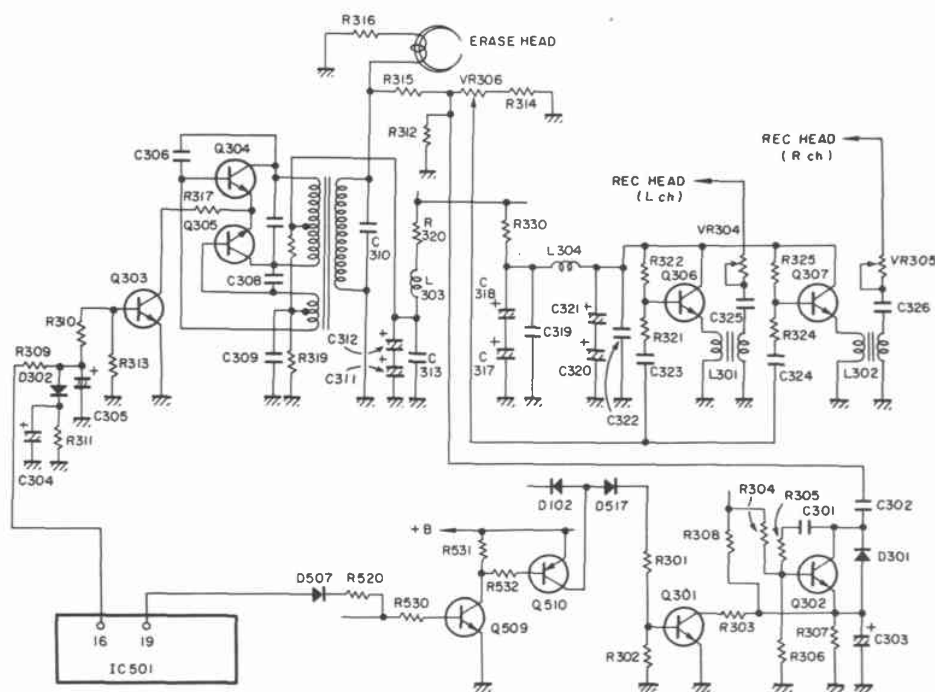

Fig. 7-11 Bias muting circuit

8. MECHANICAL ADJUSTMENTS

8.1 PINCH ROLLER PRESSURE ADJUSTMENT

1. Put the unit into the PLAY condition.
2. Using a tension gauge (Stick weighing instrument: approximately 500g full scale), gently drop the pinch arm (Fig. 8-1).
3. The force necessary to separate the pinch roller from the capstan shall be between 360 and 440g at the take-up side, and between 90 and 130g at the supply side. If outside these values, reset the pinch pressure spring.
4. If Paragraph 3 cannot be satisfied by resetting the pinch pressure spring, replace it with a new one.

8.2 TAPE SPEED ADJUSTMENT

1. Connect a frequency counter to the OUTPUT terminals.
2. Replay the 3kHz part of the test tape STD-301. Adjust the semi-fixed resistor in the motor until the frequency at the start of the tape falls within the range 2,995Hz to 3,010Hz (Fig. 8-2).
3. When the semi-fixed resistor is turned in the clockwise direction, the tape speed will increase, and vice-versa.

8.3 TAPE GUIDE ADJUSTMENT

Adjustment Standard

Put the unit into the PLAY mode, and check that the tape is running normally without curling around the head guides (Fig. 8-3).

Method of Adjustment

If the tape curls around the head guides, turn the height adjuster to the left or right so as to obtain a suitable tape height.

Post-adjustment Check

Put the unit into the PLAY mode, and check that the tape does not come into contact with the head guide.

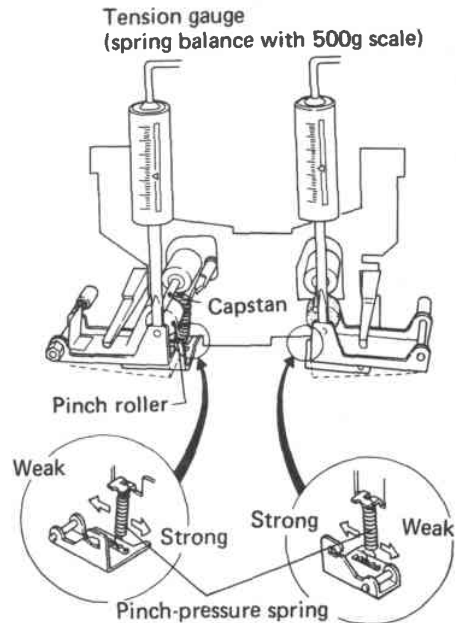

Fig. 8-1 Pinch roller pressure adjustment

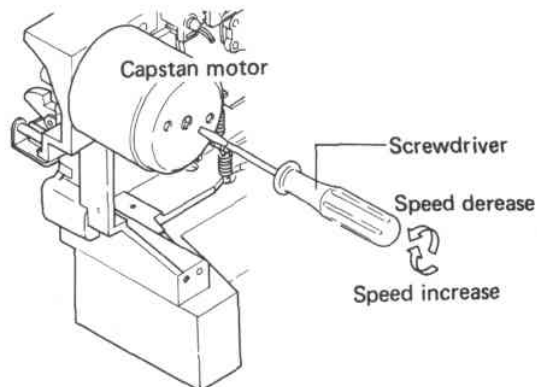

Fig. 8-2 Tape speed adjustment

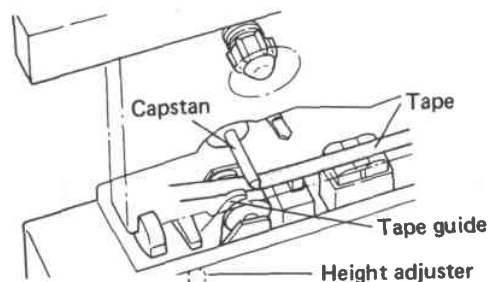

Fig. 8-3 Tape guide adjustment

9. ELECTRICAL ADJUSTMENTS

Before performing electrical adjustments, check the following items.

1. Ensure that all mechanical adjustments have been completed.
2. Adjust the measuring level to $0\text{dBv} = 1\text{V}$, and place a $50\text{k}\Omega$ ($47\text{k}\Omega$ to $52\text{k}\Omega$) dummy resistor across the line output terminals.
3. Perform adjustments using the A-side (the side with the label) of the specified test tapes.
 - STD-331A : For overall replay
 - STD-341A : For replay adjustments
 - STD-601 : STD blank tape
 - STD-603 : CrO_2 blank tape
 - STD-604 : METAL blank tape
4. Obtain the following measuring instruments. Millivoltmeter, low frequency generator oscilloscope, attenuator.
5. Unless otherwise defined, the term "recording condition" as used in this manual shall mean the condition when a cassette shell is loaded, and both the PLAY and REC switches are pressed.
6. Unless otherwise specified, adjustments shall be performed on both L and R channels.
7. Clean the heads and also remove any residual magnetism using a head demagnetizer.
8. Always perform adjustments in the specified sequence. If the sequence is changed, the performance of the unit may be degraded.

Adjustment Sequence

1. Head azimuth adjustment
2. Playback equalizer adjustment
3. Playback level adjustment
4. Level meter 0dB adjustment
5. Approximate adjustment of recording current
6. Erasure current adjustment
7. Bias trap adjustment
8. Approximate adjustment of recording bias
9. Recording equalizer and variable equalizer adjustments
10. Recording and playback frequency response adjustment
11. Recording level adjustment
12. Recording dolby NR adjustment
13. Playback dolby NR adjustment
14. Output level adjustment

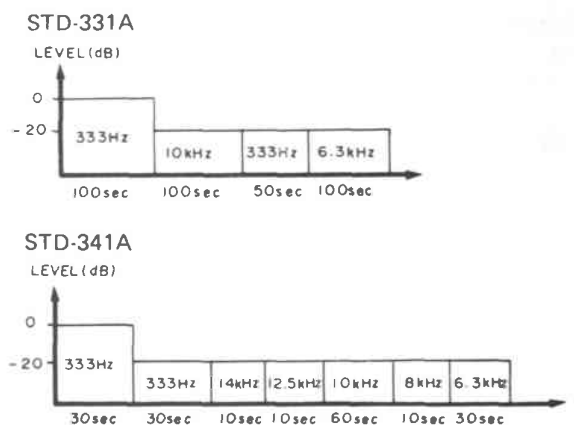

Fig. 9-1 Recorded contents of test tape

9.1 HEAD AZIMUTH ADJUSTMENT

1. Connect the millivoltmeter to the OUTPUT terminals.
2. Turn the OUTPUT level control to the maximum position, and put the TAPE switch to STD.
3. Replay the -20dB part of the 10kHz test tone on the STD-341A test tape. Turn the head azimuth adjustment screw until the output from both L and R channels becomes a maximum (Fig. 9-2).
4. After adjustment, apply lock paint to the adjustment screw.

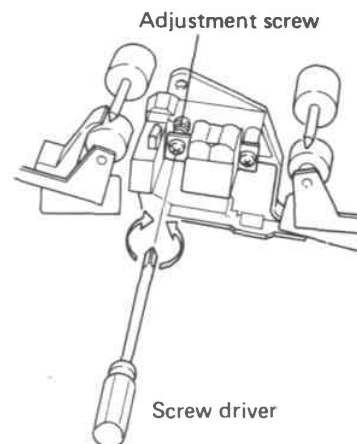

Fig. 9-2 Head azimuth adjustment

9.2 PLAYBACK EQUALIZER ADJUSTMENT

1. Connect an millivoltmeter to the OUTPUT terminals.
2. Set the TAPE switch to STD, turn VR₁₀₃ and VR₁₀₄ up to maximum positions, and VR₁₀₇ and VR₁₀₈ to central positions.
3. Play the 333Hz, -20dB portion of the STD-341A test tape, and adjust the OUTPUT volume control to obtain a -20dBv (0.1V) reading in the millivoltmeter.
4. Next play the 10kHz, -20dB portion of the same test tape, and adjust VR₁₀₁ (left channel) and VR₁₀₂ (right channel) to obtain a +1dB level difference from the 333Hz output reading.
5. Then, play back the 14kHz, -20dB (signal) and confirm with the mV meter indication that the output difference is over +0.5dB when compared with the previously played 333Hz signal. When less than 0.5dB, adjust in accordance with the flow chart on page 37.
6. Change the TAPE switch to the METAL position (or CrO₂ or Fe-Cr positions), and check that the frequency response referenced at 333Hz is within $-4.0 \pm 1\text{dB}$ at 10kHz.

9.3 PLAYBACK LEVEL ADJUSTMENT

The playback level must be carefully adjusted owing to the fact that it will determine the Dolby NR level.

1. Connect the millivoltmeter to TP terminals No. 26 (left) and No. 25 (right) on the mother

ass'y (The OUTPUT potentiometer may be set at any position).

2. Replay the 0dB part of the 333Hz test tone on the STD-341A test tape. Adjust VR₁₀₃ :L-ch. and VR₁₀₄ :R-ch. until the respective indications on the millivoltmeter become 1dBv (1.12V).

9.4 LEVEL METER 0dB ADJUSTMENT

1. Connect millivoltmeters to the TP terminals No.30 (left) and No.29 (right) on the mother ass'y.
2. Set the MONITOR switch to the SOURCE position.
3. Apply a 333Hz, -10dBv (316mV) signal to the INPUT terminals, and adjust the INPUT level controls so that the millivoltmeters read -3dBv (700mV).
4. Then immediately adjust VR₈₀₁ (left) and VR₈₀₂ (right) in the indicator amplifier ass'y so that the level meters read 0dB at this time. First turn VR₈₀₁ and VR₈₀₂ full around counterclockwise, then turn back clockwise and stop when the 0dB segment lights up.
5. Also check that the following readings are obtained in the level meters when the input signal level is changed.

Input Signal	Level Meter Reading
333Hz, -5dBv (560mV)	+5 ± 2dB
333Hz, -26dBv (50mV)	-16 ± 2dB

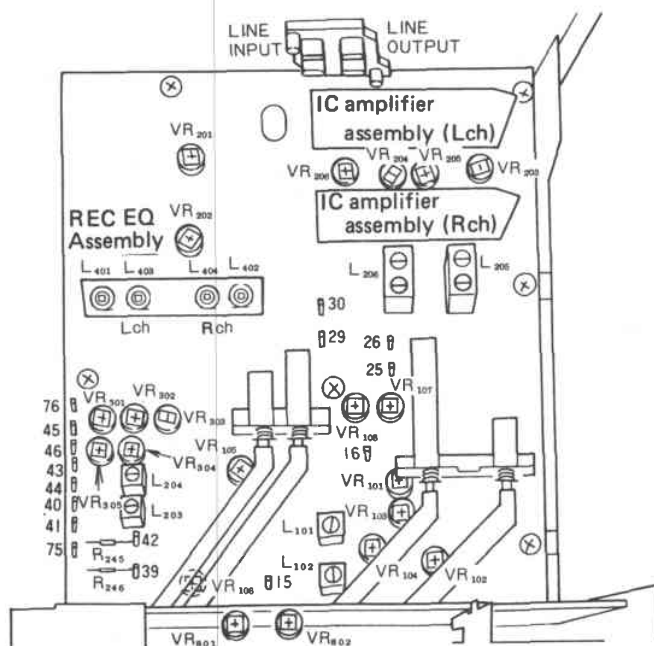

Fig. 9-3 Adjustment points

9.5 APPROXIMATE ADJUSTMENT OF RECORDING CURRENT

1. Connect millivoltmeters to the TP terminals No.30 (left) and No.29 (right) in the mother ass'y.
2. Short circuit the base of Q₃₀₃ (mother ass'y) to ground (circuit board pattern ground).
3. Set the MONITOR switch to SOURCE, and turn the DOLBY NR switch off. Then apply a 333Hz, -10dBv (316mV) signal to the INPUT terminals.
4. Start the CT-F950 in recording mode.
5. Adjust the INPUT level control to obtain readings of -3dBv (700mV) in the millivoltmeters.
6. Next connect one millivoltmeter across TP terminal No.40 (left) and ground (mother ass'y), and the other across TP terminal No.43 (right) and ground.
7. Set the TAPE switch to the STD position, and adjust VR₂₀₅ (left) and VR₂₀₆ (right) to obtain readings of 1.55mV.
8. Also check that the following readings are obtained in the millivoltmeters when the TAPE switch is changed to the other positions.

TAPE Switch Position	AC Millivoltmeter Reading
METAL	2.14mV
CrO ₂	1.84mV
Fe-Cr	1.45mV

9.6 ERASURE CURRENT ADJUSTMENT

1. Set the TAPE switch to the METAL position, and turn the INPUT volume control down to minimum level. Then connect an millivoltmeter across the mother ass'y TP terminals Nos.45 and 76.
2. Proceed in recording mode without any input signal (but with an unrecorded tape being used).
3. Adjust VR₃₀₃ so as to obtain a millivoltmeter reading of 160mV.

9.7 BIAS TRAP ADJUSTMENT

1. Connect millivoltmeters across the mother ass'y TP terminal No.42 (left) and ground, and TP terminal No.39 (right) and ground.
2. Set the TAPE switch to the METAL position, and turn the INPUT level control up to maximum level. Proceed in recording mode (with unrecorded tape) but without any input signal.
3. Adjust L₂₀₃ (left) and L₂₀₄ (right) to obtain minimum readings in the millivoltmeters.
4. Then change the MONITOR switch to the SOURCE position, and connect the millivoltmeters across the mother ass'y TP terminal No.16 (left) and ground, and TP terminal No.15 (right) and ground. Adjust L₁₀₁ (left) and L₁₀₂ (right) to again reduce the millivoltmeter readings to minimum level.

Note:

This adjustment must be performed as carefully as possible since the result will influence the frequency response during recording and playback modes when the DOLBY NR switch is on.

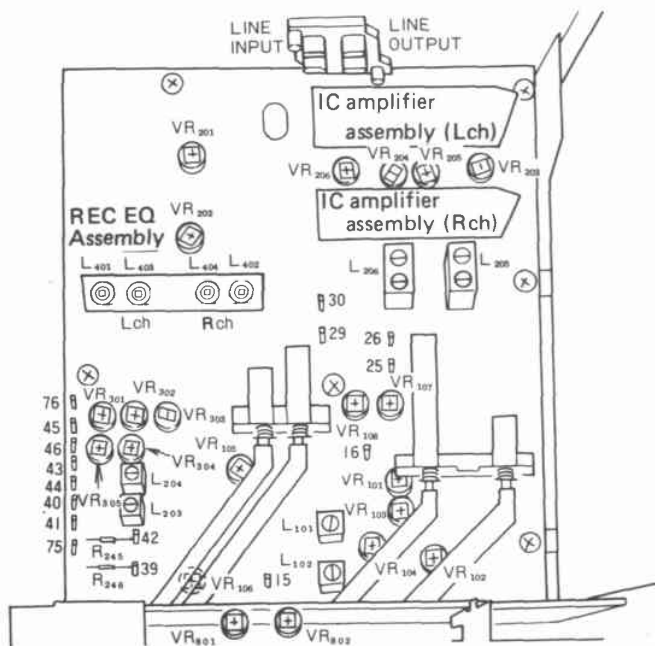

Fig. 9-4 Adjustment points

9.8 APPROXIMATE ADJUSTMENT OF RECORDING BIAS

1. Set the BIAS control to the center click-stop position, and the TAPE switch to the METAL position. Then proceed with the CT-F950 in recording mode.
2. Connect an millivoltmeter across the mother ass'y TP terminal No.40 (left) and ground, and another meter across TP terminal No.43 (right) and ground.
3. Adjust VR₃₀₅ (left) and VR₃₀₄ (right) so that the meters read 12mV.
4. Next change the TAPE switch to STD, and adjust VR₃₀₁ to obtain meter readings of 6mV. Change the switch again to the CrO₂ position, and adjust VR₃₀₂ to obtain meter readings of 9.5mV.
5. Then set the MONITOR switch to the SOURCE position, and apply a 333Hz, -10dBv (316mV) signal to the INPUT terminals.
6. Connect the millivoltmeters to the OUTPUT terminals, and adjust the INPUT level controls so that the meters read -10dBv (316mV).
7. After completing the above adjustments, set the MONITOR switch to the TAPE position, and record and play back the 333Hz, -10dBv (316mV) signal onto/from the STD-601 test tape. Then after first turning VR₃₀₅ (left) and VR₃₀₄ (right) counterclockwise, turn them back clockwise and stop at the maximum position.

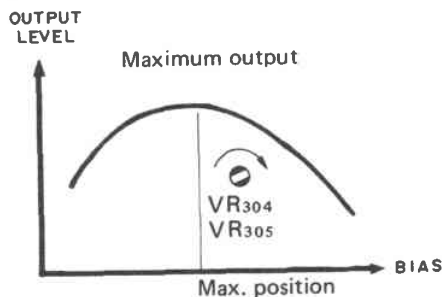

Fig. 9-5 Output level

9.9 RECORDING EQUALIZER AND VARIABLE EQUALIZER ADJUSTMENTS

1. Connect millivoltmeters to the mother ass'y TP terminals No.30 (left) and No.29 (right).
2. Short circuit the base of Q₃₀₃ (mother ass'y) to ground (circuit board pattern).
3. Set the MONITOR switch to SOURCE, and apply a 333Hz, -10dBv (316mV) signal to the

INPUT terminals. Then proceed in recording mode.

4. Adjust the INPUT level controls to obtain meter readings of -3dBv (700mV).
5. Next connect an millivoltmeter to TP terminal No.5 in the IC amplifier ass'y, and adjust VR₂₀₃ and VR₂₀₄ to obtain the same output levels for the 333Hz and 10kHz input signals. (Variable equalizer adjustment).
6. Then set the TAPE switch to the STD position, and connect millivoltmeters across the mother ass'y TP terminal No.40 (left) and ground, and TP terminal No.43 (right) and ground. Switch the input to 15kHz and obtain the same AC millivoltmeter readings by employing an attenuator in the input stage. Adjust L₄₀₁ (left) and L₄₀₂ (right) so that the amount of attenuation required is 13.0dB. (STD recording equalizer adjustment).
7. Change the TAPE switch setting to METAL, and adjust in the same way as described above in step 6. In this case, adjust L₄₀₃ and L₄₀₄ so that the attenuation required will be 16.0dB. (METAL recording equalizer adjustment).
8. Finally set the TAPE switch to the CrO₂ and Fe-Cr positions, the required amount of attenuation being 19.6 ± 1.5 dB and 12.6 ± 1.5 dB respectively.

9.10 RECORDING AND PLAYBACK FREQUENCY RESPONSE ADJUSTMENT

1. Connect millivoltmeters to the OUTPUT terminals.
2. Set the TAPE switch to STD, and the MONITOR switch to SOURCE, and apply a 333Hz, -30dBv (31.6mV) signal to the INPUT terminals. Adjust the INPUT level controls so as to obtain meter readings of -27dB (44.6mV).
3. Set the Monitor switch to TAPE, record 333Hz, -30dBv (31.6mV) and 10kHz, -30dBv signals onto the STD-601 test tape. Play these sections back again, and adjust VR₃₀₄ (left) and VR₃₀₅ (right) so that the output difference between these two signals is about 0dB at 10kHz.
4. Then, confirm that the record/playback frequency response of test tape STE-601 is within the fixed standard range (page 40).
5. Set the tape selector switch to METAL, and use the STD-604 test tape as in the previous instructions. Record the 333Hz and 10kHz signals and play them back. Then, confirm that the playback output deviation of the 10kHz signal is within $+1 \pm 1$ dB of the 333Hz signal.

- When a certain type of tape does not meet with the standards specified in section 4, confirm that the adjustments are within the standards of recording and playback frequency response adjustment with the Dolby NR switch on, and then adjust VR205 (Lch) and VR206 so that the value in section 3 is within the range of $-2.5 \pm 0.5\text{dB}$ ($800 - 710\text{mV}$).

9.12 OUTPUT LEVEL ADJUSTMENT

- Connect millivoltmeters to the mother ass'y TP terminals No.26 (L-ch) and No.25 (R-ch), and turn VR103 and VR104 down to minimum positions.
- Apply the 333Hz signal to the mother ass'y TP terminals No.16 (left) and No.15 (right), and adjust the INPUT level controls so that the millivoltmeters read -3dBv (700mV).
- Set the OUTPUT level controls to the center click-stop positions, and connect millivoltmeters to the OUTPUT terminals. Adjust VR107 (left) and VR108 (right) so as to obtain meter readings of -7dBv (446mV).

9.13 RECORDING DOLBY NR ADJUSTMENT

- Connect up the millivoltmeter to TP terminals No.29 (left) and No.30 (right) on the mother ass'y.
- Apply a -10dBv (316mV) 1kHz signal to the INPUT terminals.
- Put the DOLBY NR switch off, and then adjust

the INPUT potentiometer so that the indication on the millivoltmeter becomes 0dBv (1V).

- Next, set the level of the input signal of Paragraph 2 above, to -50dBv (3.16mV).
- Put the DOLBY NR switch on. Adjust VR201 (left) and VR202 (right) so that the millivoltmeter indication becomes -34dBv (19.9mV).

9.14 PLAYBACK DOLBY NR ADJUSTMENT

- Connect the millivoltmeter to terminals No.25 (left) and No.26 (right) on the mother ass'y.
- Put VR103 and VR104 in the minimum settings.
- Apply a 1kHz signal to TP terminals No.15 (left) and No. 16 (right) on the mother ass'y. Adjust the input level so that the millivoltmeter indication becomes 0dBv (1V).
- Next, apply an input which is 34dB below that of paragraph 3 above.
- Put the DOLBY NR switch on. Adjust VR106 : L-ch and VR105 : R-ch. so that the indication on the millivoltmeter becomes -40dBv (1mV).

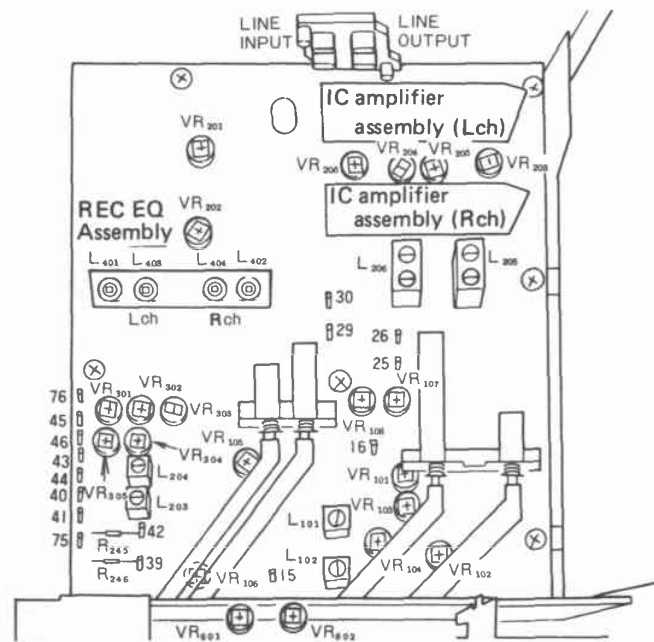

6. If outside the specified standards, refer to "9-6, ERASURE CURRENT ADJUSTMENT" and adjust VR303 so that the value is within the range of $160 \pm 20\text{mV}$.
 7. Then, confirm that the record/playback frequency response for metal tape is within the fixed standard range.
 8. Set the tape selector switch to CrO_2 and using test tape STD-603 as in the previous instructions, record and play back the 333Hz and 10kHz signals. Then confirm that the playback output deviation of the 10kHz signal is within $0 \pm 1\text{dB}$ of the 333Hz signal. If outside the specified standards, adjust VR302.
 9. Then, confirm that the record/playback frequency response for test tape STD-603 is within the fixed standard range (page 40).
 10. Set the tape selector switch to Fe-Cr; record and play back the 333Hz and 10kHz signals on a SONY DUAD C-60 and confirm that they are within the fixed standard range (page 40).
 11. Set the Dolby switch to ON, and confirm that the record and playback frequency response for all types of tapes is within the fixed standard range (page 40).
- * when making adjustments, also refer to the flow chart on page 37.

9.11 RECORDING LEVEL ADJUSTMENT

NOTE:

Since this adjustment sets the recording level, it must be performed accurately.

1. Set the MONITOR switch to SOURCE, and apply a 333Hz, -10dBv (316mV) signal to the INPUT terminals.
2. Turn the DOLBY NR switch off, and connect millivoltmeters to the mother ass'y TP terminals No.30 (left) and No.29 (right). Adjust the INPUT level control so that the meters read -3dBv (710mV).
3. Then set the TAPE switch to the STD position, and turn the DOLBY NR switch on, and also change the MONITOR switch to the TAPE position. Record the 333Hz -10dBv (316mV) signal onto the STD-601 test tape, and adjust VR₂₀₅ (left) and VR₂₀₆ (right) so as to obtain millivoltmeter readings of -2.5dBv (750mV) during playback.
4. Set the TAPE switch to CrO_2 , and then to METAL, and record the 333Hz, -10dBv (316mV) signal onto the STD-603 test tape and the STD-604 test tape respectively as described above under step 3. During playback with both tapes, check that millivoltmeter readings are within -3dBv (710mV) $\pm 1.5\text{dB}$ in the both cases.

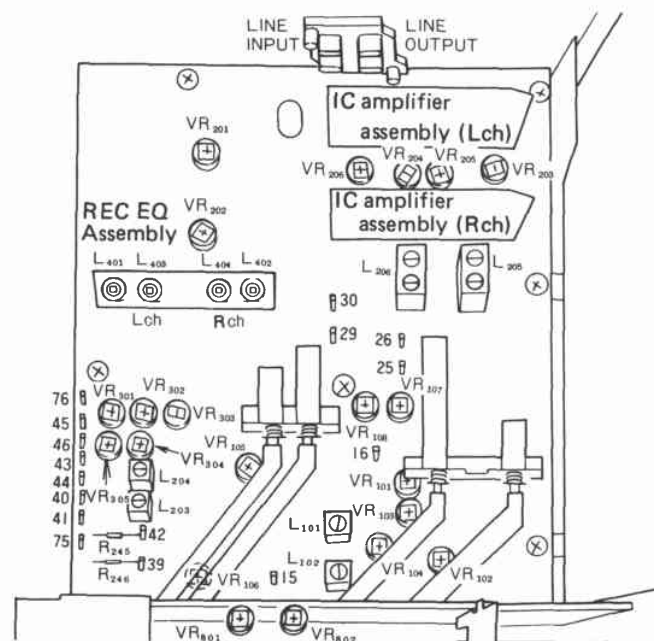
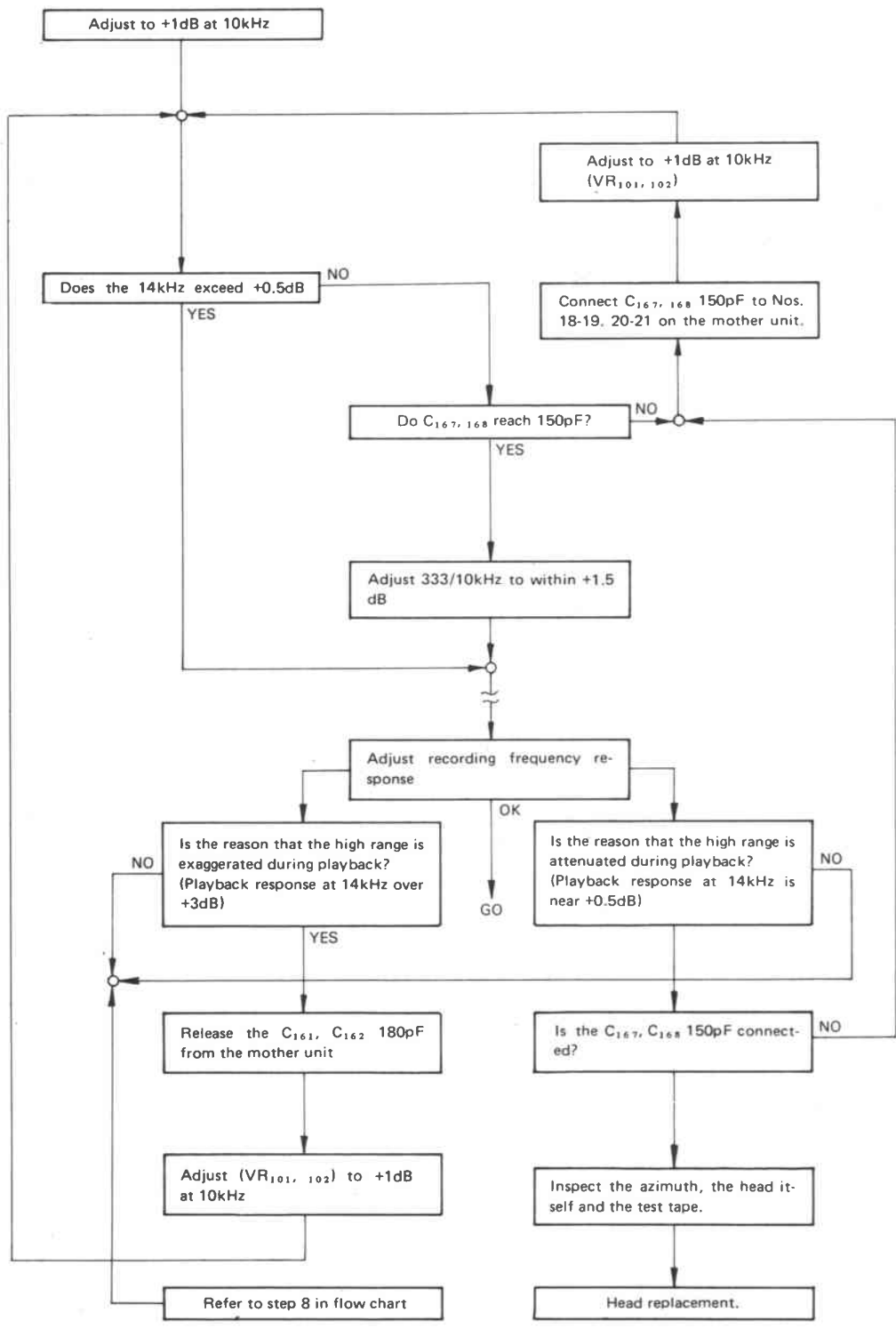
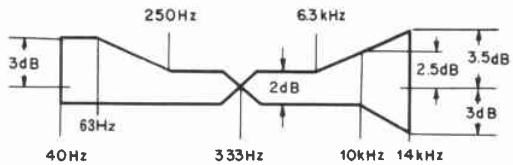

Fig. 9-6 Adjustment points

Playback adjustment flow chart





* Using STD-331A and the STD position, with DOLBY NR OFF.

Note:

The frequency characteristics for the R channel shall be obtained by subtracting 1dB from the value indicated on the meter at 40Hz and 63Hz respectively.

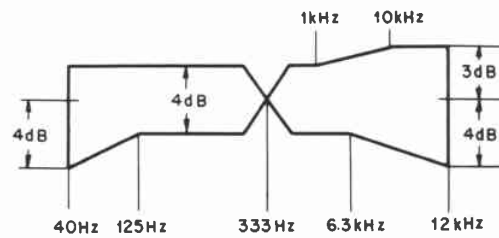

* Using STD-603 and the CrO₂ position, with DOLBY NR OFF.

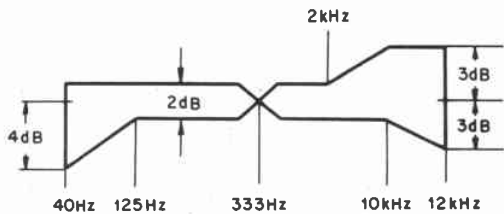

* Using STD-601 and the STD position, with DOLBY NR OFF.

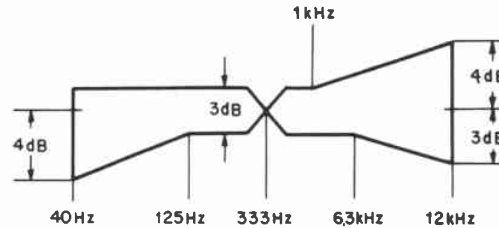

* Using SONY DUAD C-60 and the Fe-Cr position, with DOLBY NR OFF.

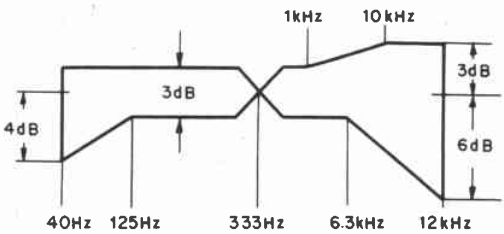

* Using STD-601 and the STD position, with DOLBY NR ON.

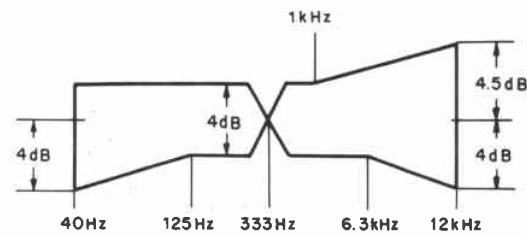

* Using SONY DUAD C-60 and the Fe-Cr position, with DOLBY NR ON.

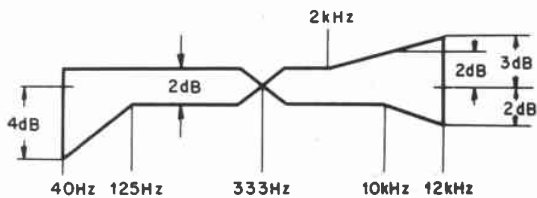

* Using STD-603 and the CrO₂ position, with DOLBY NR ON.

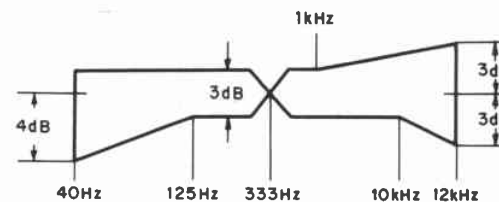

* Using STD-604 and the METAL position, with DOLBY NR OFF.

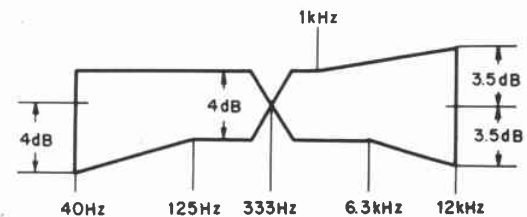

* Using STD-604 and the METAL position, with DOLBY NR ON.

Record adjustment flow chart

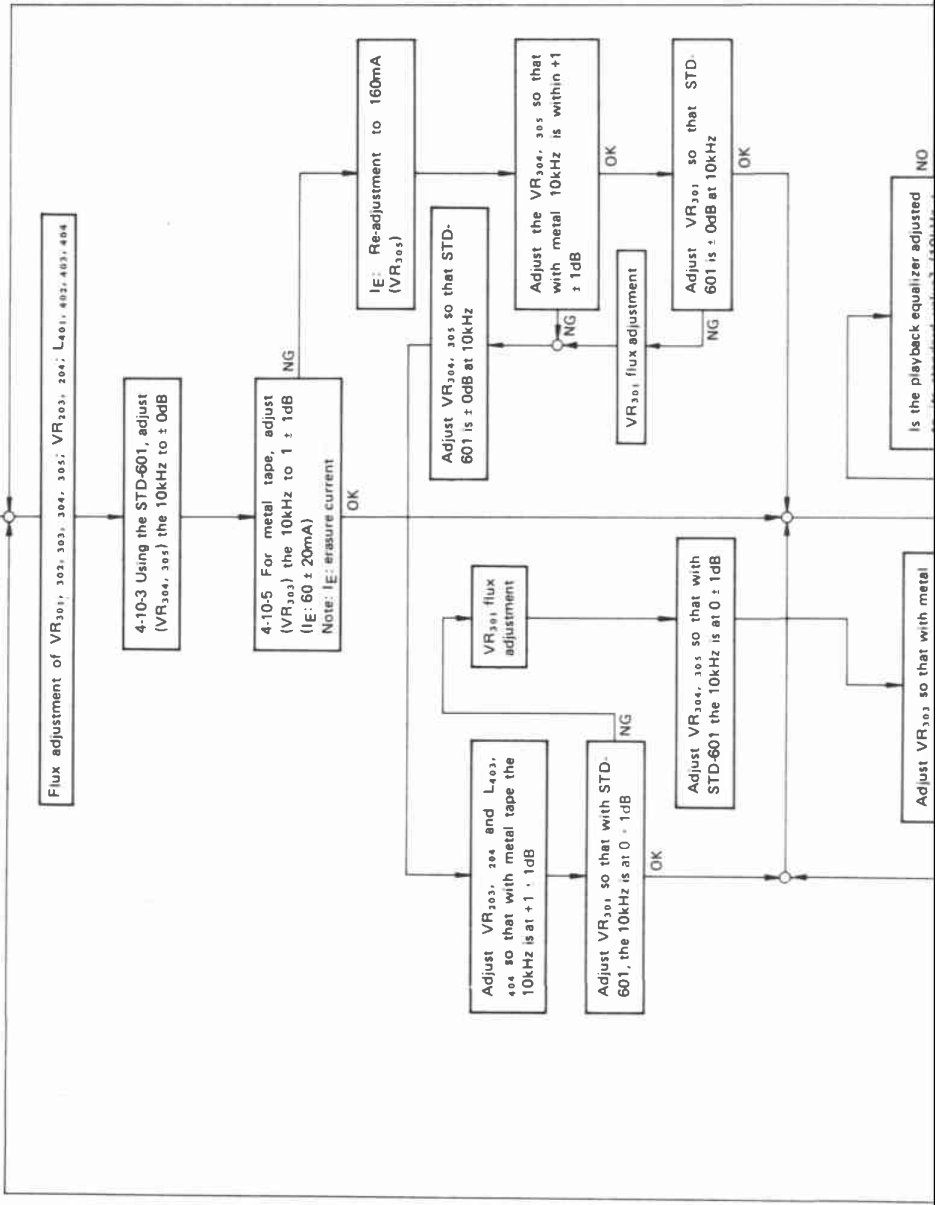

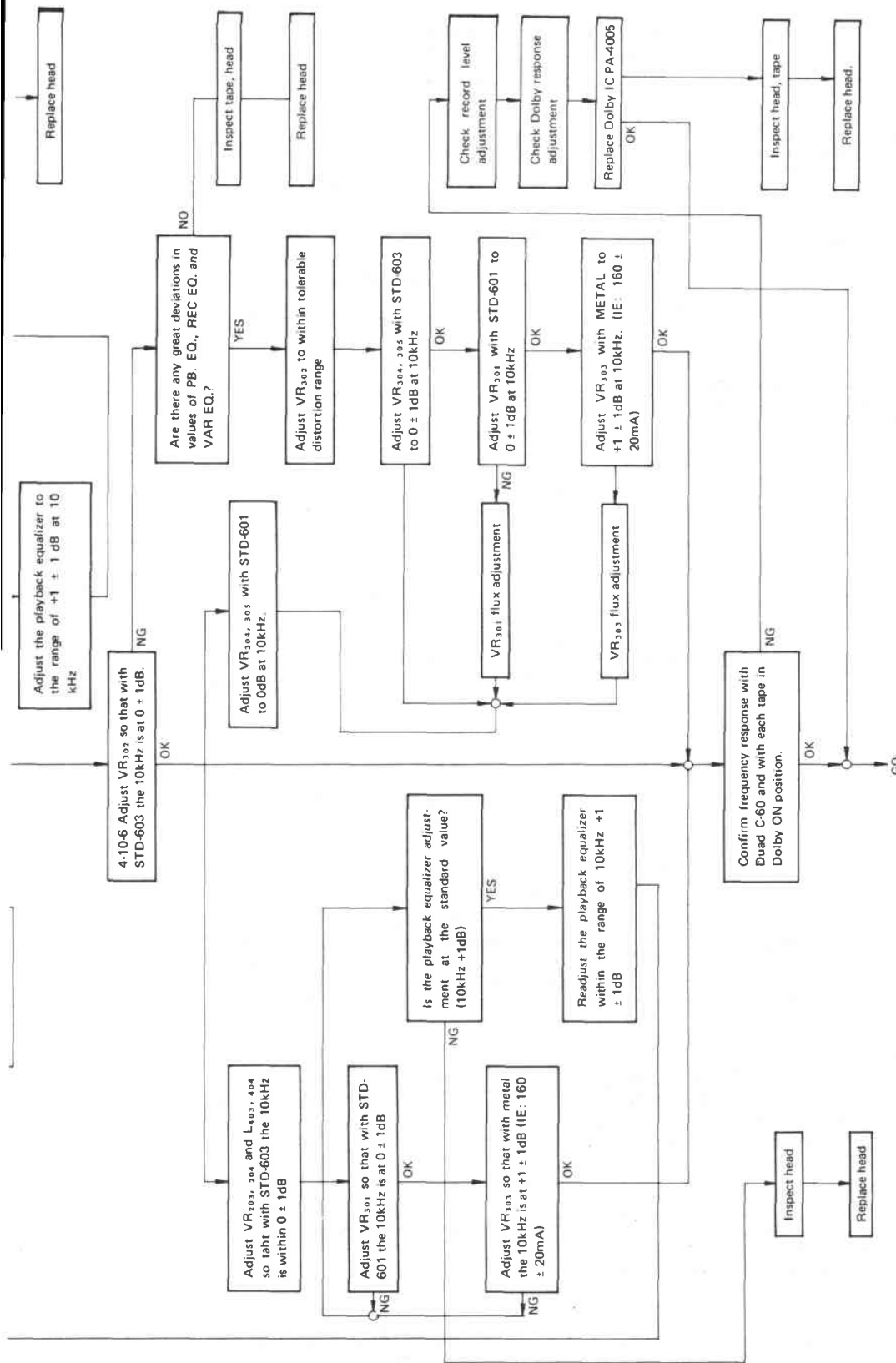

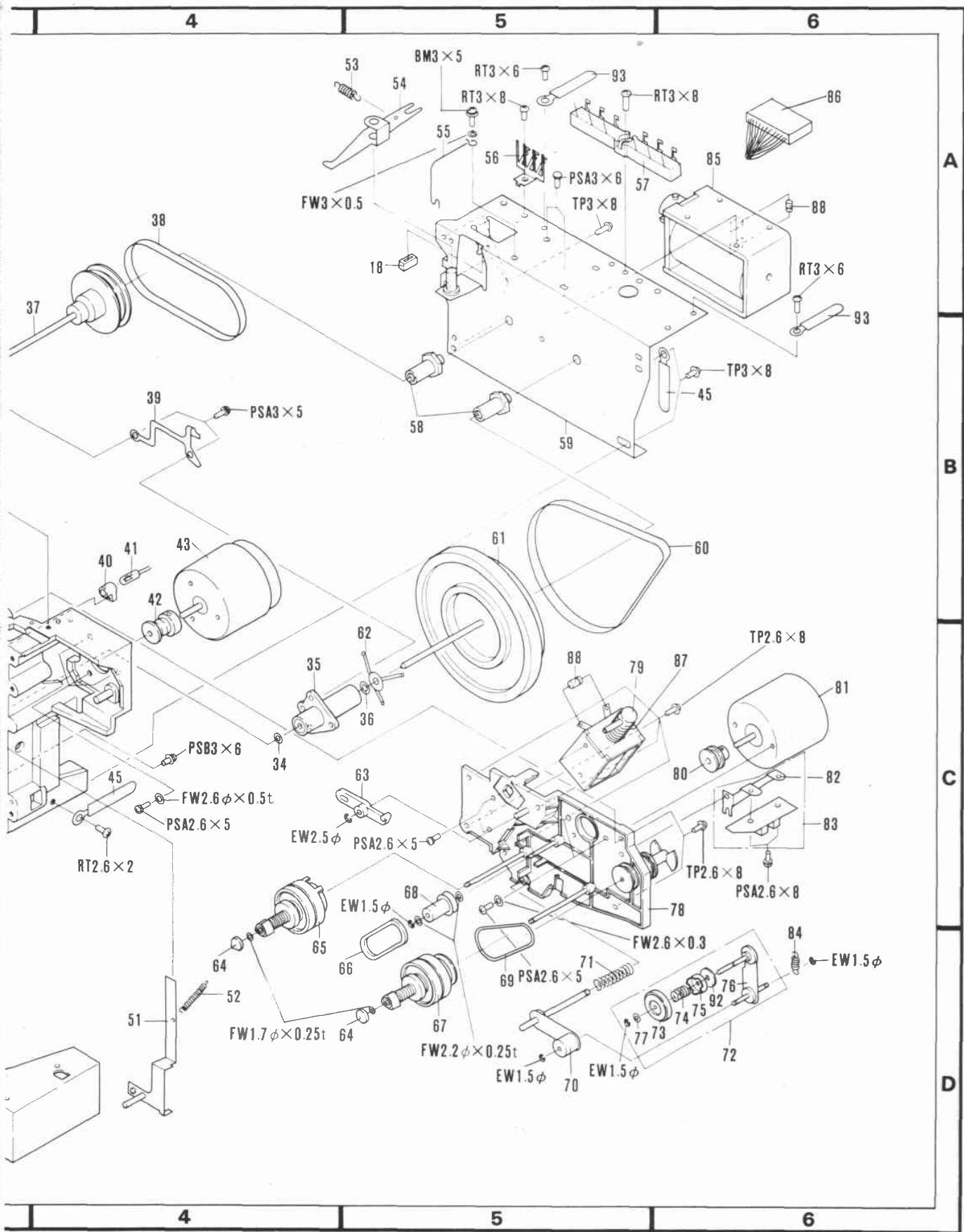

10. PACKING

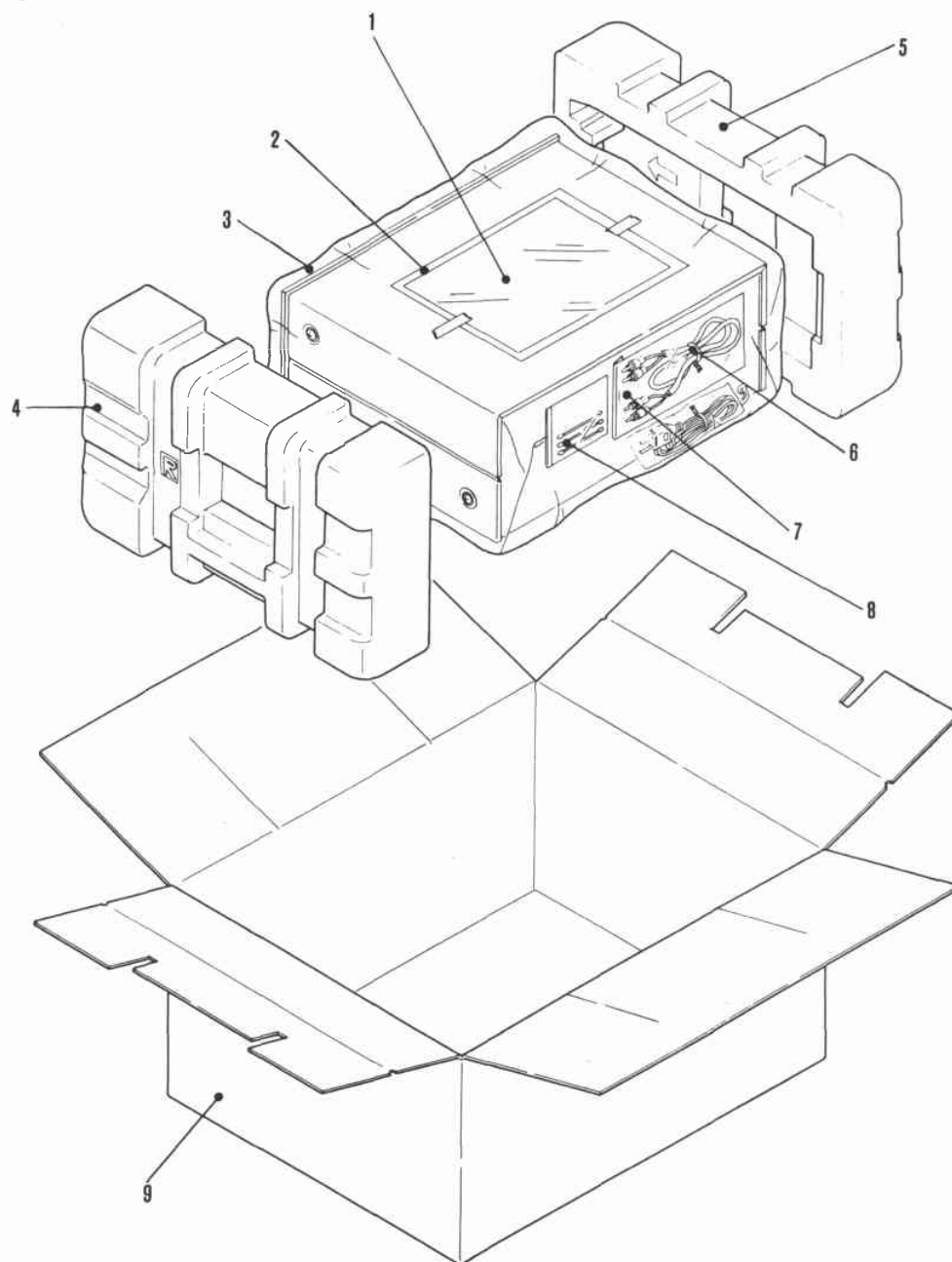

Parts List

Key No.	Part No.	Description	Key No.	Part No.	Description
1.	RRB-106	Operating instructions	6.	RDE-010	Connection cord
2.	RHL-018	Vinyl bag (for operating instructions)	7.	RHL-019	Vinyl bag (for connection cord)
3.	RHL-031	Vinyl bag (for cassette tape deck)	8.	REA-021	Head cleaning assembly
4.	RHA-175	Side pad R	9.	RHG-282	Packing case (for KU type)
5.	RHA-174	Side pad L		RHG-281	Packing case (for KC type)

11. EXPLODED VIEWS

11.1 EXTERIOR

● Parts without part number cannot be supplied.

Key No.	Part No.	Description	Key No.	Part No.	Description
1.		Mechanism assembly	46.	RWX-359	Mother assembly
2.		Panel stay (B)	47.	RCS-020	Volume 5k-B (BIAS)
3.	RAC-094	Power knob	48.		Shield cover
4.		Switch joint-bar (D)	49.		Mother P.C. board
5.	RSA-021	Power switch	50.	RSG-064	Push switch (A)
6.	RWG-103	Control assembly	51.	RSG-068	Push switch (B)
7.		Bracket	52.	RKB-014	4P mount pinjack
8.		UL cord clamber (B)		(RKB-016)	
9.	RNK-777	Half cover (M)	53.	RWX-360	IC amp assembly
10.	RAC-108	Function switch knob	54.	RKN-046	Headphone jack
11.		Function switch unit	55.	RKN-044	MIC jack
12.		Panel holder	56.	RWX-361	REC EQ assembly
13.		Rubber bush	57.	REB-233	Cover cushion
14.	RXX-251	Front panel assembly	58.	RAH-287	Half cover panel
15.		Power knob guide	59.	RWX-109	Spark killar (UL)
16.		Lens		RWX-150	Spark killar (KC)
17.	RNK-566	Guide L	60.	REC-250	Capacitor cover D
18.	RNK-608	Guide R	61.	RAH-286	Function panel
19.	RBA-045	Screw (B)	62.	RBA-038	Screw
20.		Nylon washer 4φ x 6φ x 0.2t	63.	RBM-004	Wire nut
21.	REF-014	Steel ball	64.	RRW-112	UL Caution label (A)
22.	RBK-132	Spring	65.	RBA-026	Screw
23.	RXB-169	Head cover assembly			
24.	RAH-285	Escutcheon panel			
25.	RNK-731	Escutcheon lens			
26.	RBA-044	Screw (A)			
27.	RNK-780	Escutcheon (M)			
28.	RWR-067	Power supply assembly			
29.		Heat sink			
30.		Power supply P.C. board			
31.	RTT-175	Power transformer (KU)			
	RTT-185	Power transformer (KC)			
32.		Terminal 1P			
33.	REC-272	Strain relief			
34.	RXA-905	Foot assembly			
35.		Chassis			
36.		Bottom plate			
37.		Screw M4 x 8			
38.		Rear panel			
39.	RDG-022	Power cord			
40.	RNA-364	Bonnet			
41.	REB-223	Rubber (D)			
42.		Switch joint-bar (C)			
43.		Switch joint-bar (B)			
44.		Switch joint-bar (A)			
45.	RAC-091	Push knob (A)			

10. PACKING

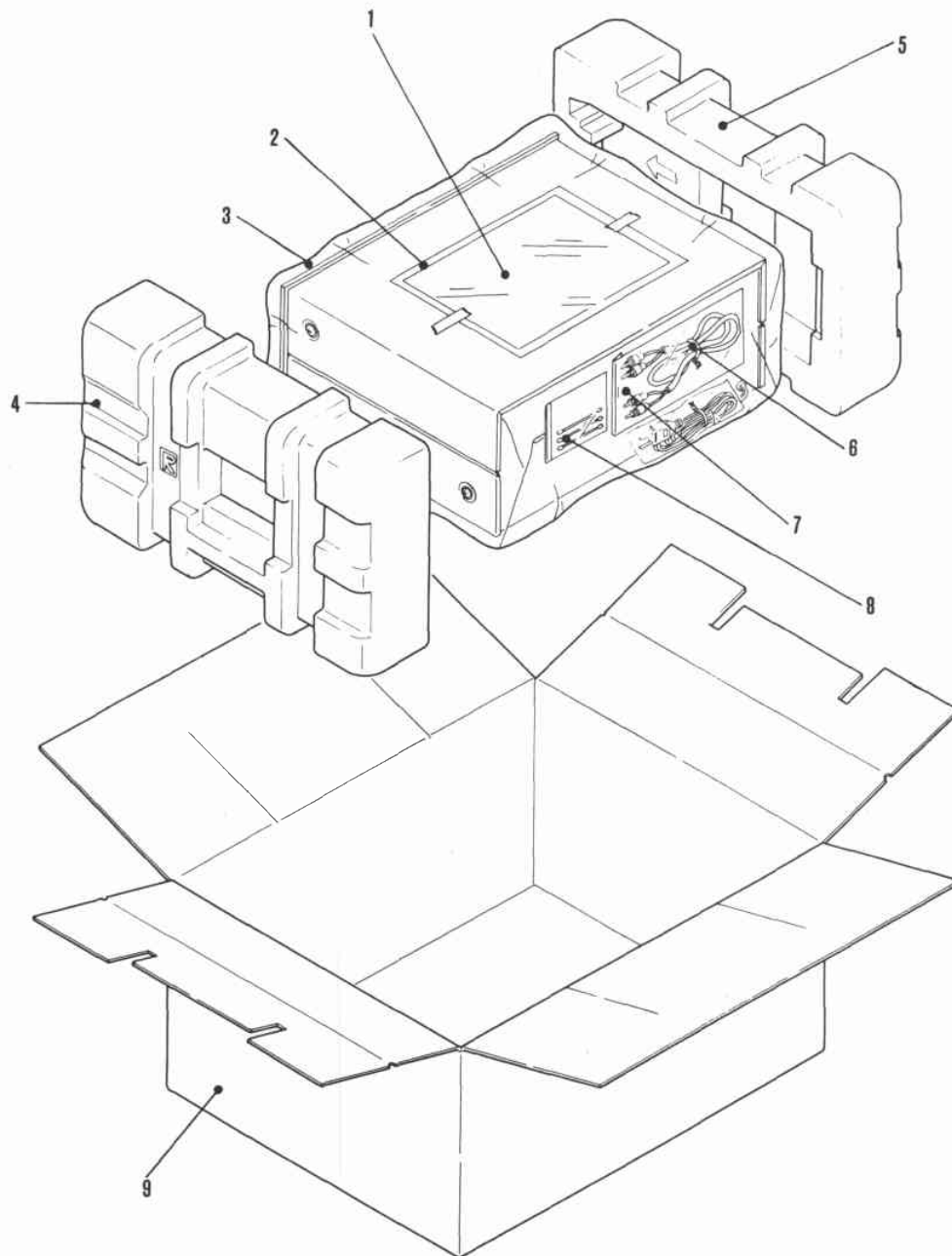

Parts List

Key No.	Part No.	Description	Key No.	Part No.	Description
1.	RRB-106	Operating instructions	6.	RDE-010	Connection cord
2.	RHL-018	Vinyl bag (for operating instructions)	7.	RHL-019	Vinyl bag (for connection cord)
3.	RHL-031	Vinyl bag (for cassette tape deck)	8.	REA-021	Head cleaning assembly
4.	RHA-175	Side pad R	9.	RHG-282	Packing case (for KU type)
5.	RHA-174	Side pad L		RHG-281	Packing case (for KC type)

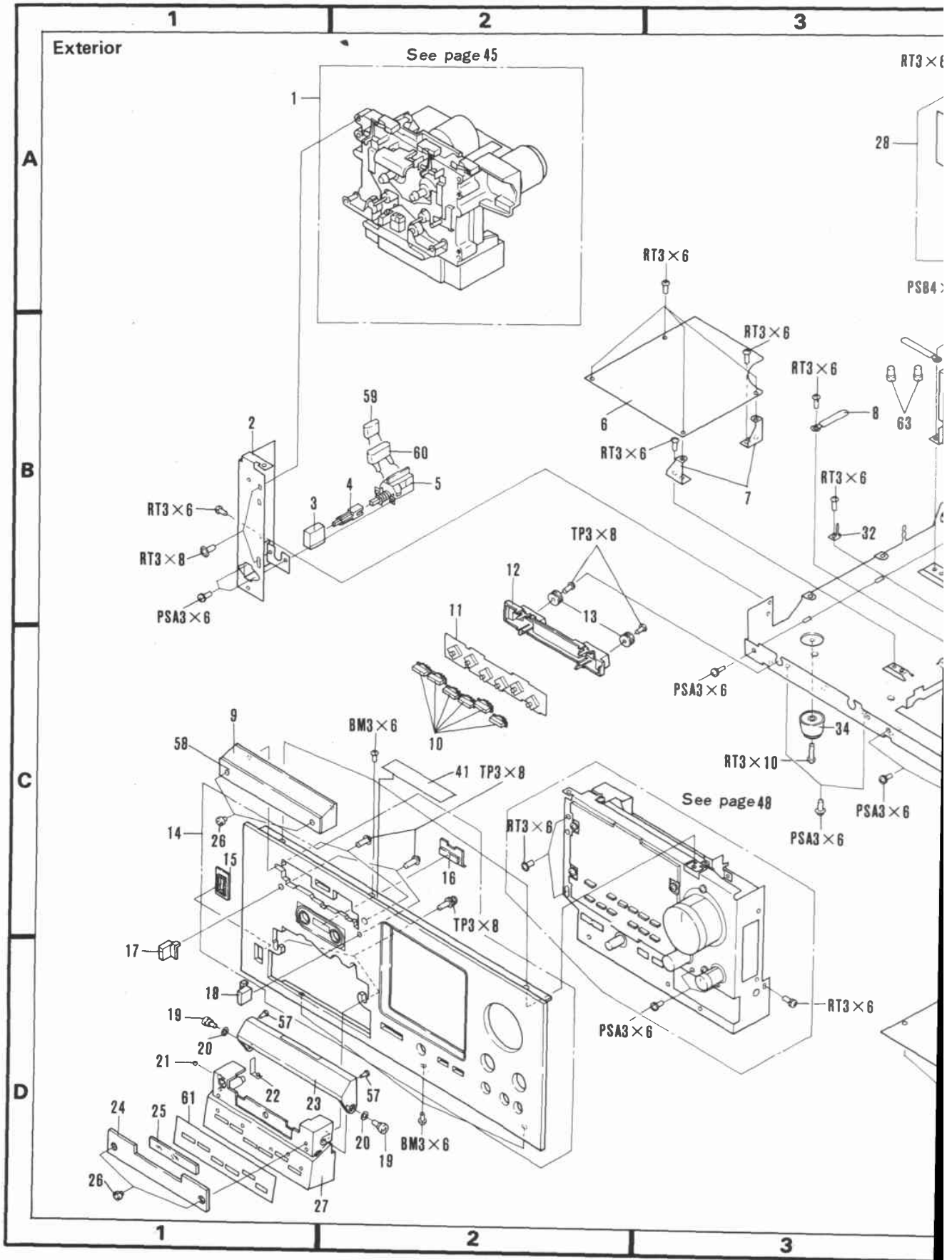

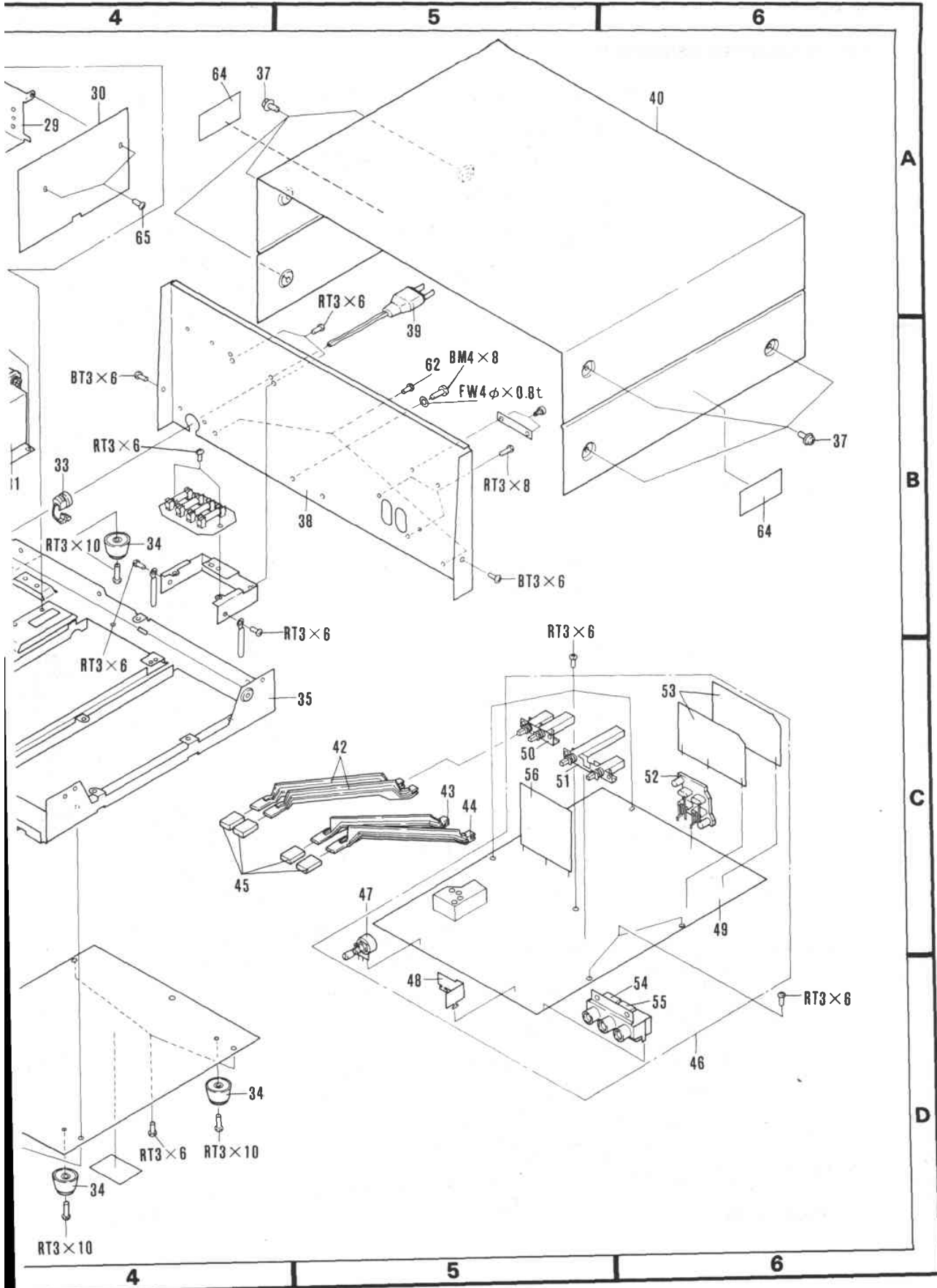

11.3 PANEL STAY

● *Parts without part number cannot be supplied.*

Key No.	Part No.	Description	Key No.	Part No.	Description
1.	RWX-328	Indicator amp assembly	16.	RED-145	Volume mask
2.		P.C. holder	17.	RXX-252	Indicator lens assembly
3.	RSG-066	Switch (E)	18.		Indicator lens
4.	RSG-067	Switch (F)	19.		Indicator panel (M)
5.		Indicator P.C. assembly	20.		Meter lens
6.		Shield cover	21.	RAA-231	BIAS VR knob
7.		Holder (M)	22.	RED-047	Switch mask
8.		Holder (C)	23.	RAA-301	Tape selector knob assembly
9.		Indicator unit	24.	RAA-227	PB VR knob (L) assembly
10.	LD8242	Fluorescent indicator tube	25.	RAA-229	PB VR knob (R) assembly
11.	FIP 5D 8	Fluorescent indicator tube	26.	RED-151	Volume mask
12.		Indicator P.C. board	27.		Panel stay (M)
13.	RAC-093	Push knob (C)	28.		Volume unit
14.	RAA-223	REC VR knob (L) assembly	29.		Shield cover (tape selector)
15.	RAA-225	REC VR knob (R) assembly	30.		Shield cover (M)
			31.		Tape selector assembly

Parts List

● Parts without part number cannot be supplied.

Key No.	Part No.	Description	Key No.	Part No.	Description
1.		Arm assembly	51.		Half detector arm assembly
2.		Arm	52.	RBH-524	Spring
3.		Arm	53.	RBH-506	Spring
4.	RBH-511	Spring	54.		Solenoid lever
5.	RSF-022	Microswitch	55.	RBH-557	Spring
6.	REC-278	Spacer	56.		Terminal 4P
7.	RSF-024	Microswitch (B)	57.		6P plug
8.		Switch bracket	58.		Screw
9.		Detector arm	59.		Solenoid chassis assembly
10.	RNK-556	Half holder	60.	REB-270	Capstan belt
11.	RBH-534	Spring	61.	RXB-055	Flywheel assembly
12.	RBH-563	Spring	62.	RBK-107	Spring
13.		Brake plate	63.		Brake operation lever
14.	REB-187	Brake shoe	64.	RNK-815	Reel cap (B)
15.	RBK-119	Head base holder	65.	RXB-189	Supply reel assembly (B)
16.	RBF-013	Steel ball	66.	REB-317	TU belt
17.		Head base assembly	67.	RXB-190	Take-up reel assembly (B)
18.	REB-153	Stopper	68.	RXA-998	Take-up pulley assembly
19.	RNK-348	Tape guide	69.	REB-272	Sensing belt
20.	RBH-374	Spring	70.		Arm assembly
21.	RNK-535	Adjuster	71.	RBH-502	Spring
22.	RXB-005	Pinch-roller arm assembly	72.	RXB-144	Idler arm full assembly
23.		Arm (B)	73.	RNK-561	Idler
24.	RBH-516	Spring	74.	RBH-498	Spring
25.		Arm (A)	75.	RNK-562	Spring holder
26.	RBH-373	Spring	76.		Idler arm assembly
27.		Socket-head screw M2.6 x 5 Ni	77.		Washer 2.2φ x 5φ x 0.5t
28.	RXB-255	Sub-head base assembly	78.		Sub-chassis assembly
29.		Terminal 3φ	79.	RXP-056	Solenoid (B)
30.		Cord clamber	80.	RXB-064	Motor pulley (B) assembly
31.	RNK-703	Head cord cover	81.	RXM-047	Take up motor
32.	RLA-994	Pinch-roller arm shaft (L)	82.		Sensing holder
33.	RLA-993	Pinch-roller arm shaft (R)	83.		Sensing unit
34.	RBF-037	Washer	84.	RBH-564	Spring
35.	RXB-093	Bearing assembly	85.	RXP-062	Solenoid (A)
36.		Washer 3φ x 6φ x 0.5t	86.	RKP-044	Connector (13p)
37.	RXB-058	Supply pulley assembly	87.	RBH-507	Spring
38.	REB-314	Sub belt	88.	W03B	Diode
39.		Terminal (GND)	89.	RNF-527	Spacer
40.	REB-297	Lamp holder	90.	RBH-505	Spring
41.	REL-072	Lamp (B)	91.	REB-194	Rubber
42.	RXB-063	Motor pulley Assembly	92.		Friction felt
43.	RXM-050	Motor	93.		UL cord clamber (B)
44.		Chassis			
45.		UL cord clamber (D)			
46.		Half holder bracket L assembly			
47.	RNK-534	Half holder arm			
48.	RBH-503	Spring			
49.		Half holder bracket R assembly			
50.		Mechanism holder			

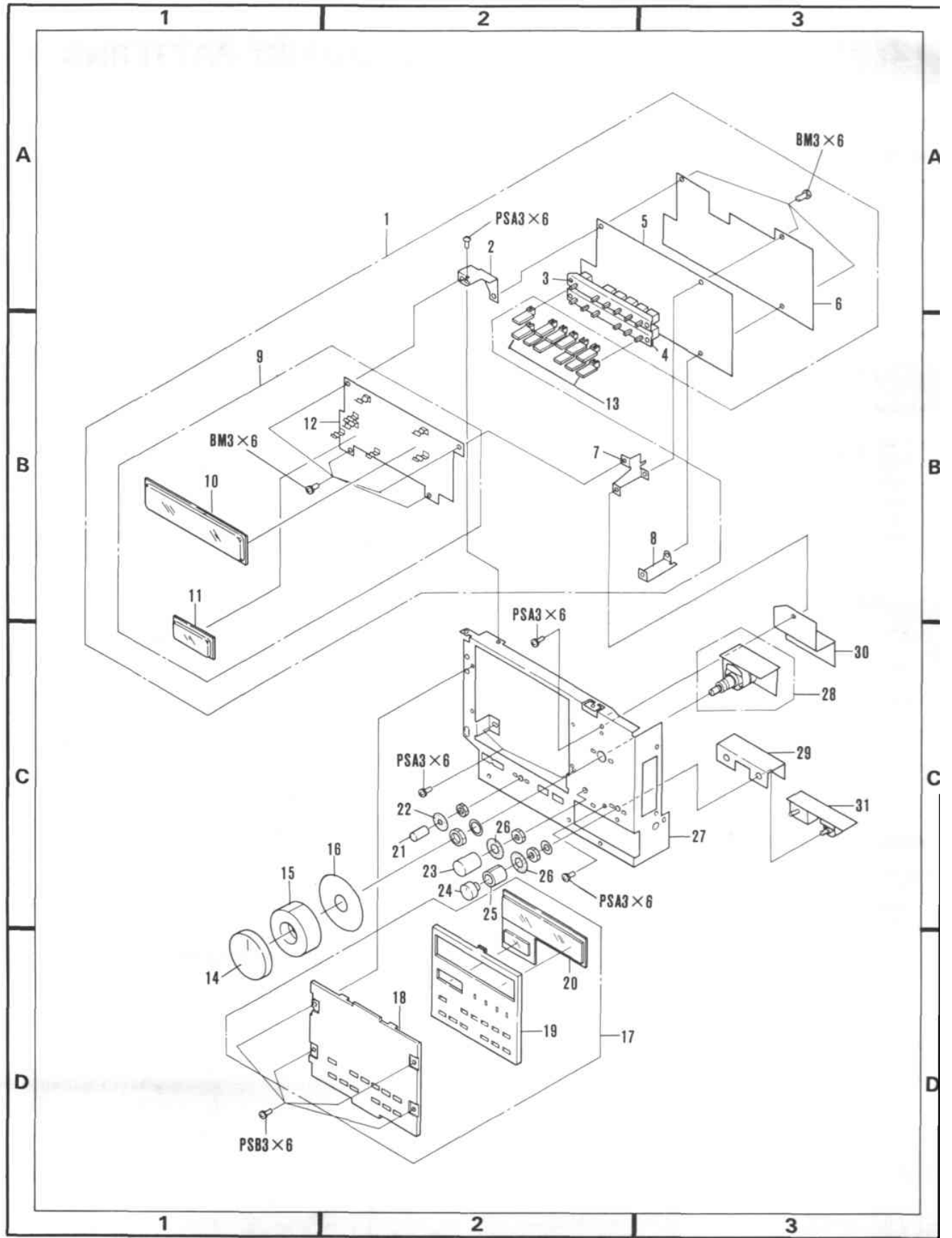

12. SCHEMATIC DIAGRAMS P.C. BOARD PATTERNS AND PARTSLIST

12.1 MISCELLANEOUS PARTS LIST

NOTE:

- When ordering resistors, first convert resistance values into code form as shown in the following examples.

Ex. 1 When there are 2 effective digits (any digit apart from 0), such as 560 ohm and 47k ohm (tolerance is shown by J = 5%, and K = 10%).

560Ω — 56 × 10¹ — 561 RD¼PS 561 J
 47kΩ — 47 × 10³ — 473 RD¼PS 473 J
 0.5Ω — 0R5 RN2H 0R5 K
 1Ω — 010 RS1P 010 K

Ex. 2 When there are 3 effective digits (such as in high precision metal film resistors).

5.62kΩ 562 × 10¹ 5621 RN¼SR 5621 F

ASSEMBLIES

Part No.	Description
RWX-359	Mother assembly
RWX-328	Indicator amplifier assembly
RWR-067	Power supply assembly
RWX-360	Integrated amplifier assembly
RWG-103	Control assembly

OTHERS

Part No.	Symbol & Description
RWX-109	CR001 Spark killer (CT-F950/KU)
RWX-150	CR001 Spark killer (CT-F950/KC)
RXP-062	SL1101 Solenoid A (PINCH SOL.)
RXP-056	SL1102 Solenoid B (BRAKE SOL.)
REL-072	PL1101 Lamp B (CASSETTE-LAMP)
RXM-050	Motor
RXM-047	Take-up motor
RDG-022	Power cord

SWITCHES

Part No.	Symbol & Description
RSA-021	S001 Power switch (CT-F950/KC, KU)
RSF-024	S1102 Microswitch B (CASSETTE HALF DETECTOR)
RSF-022	S1103 Microswitch (ERASE PREVENT DETECTOR)

TRANSFORMER

Part No.	Symbol & Description
RTT-175	T001 Power transformer (CT-F950/KU)
RTT-185	T001 Power transformer (CT-F950/KC)

SEMICONDUCTORS

Part No.	Symbol & Description
W03B	D1101, D1102 Diode

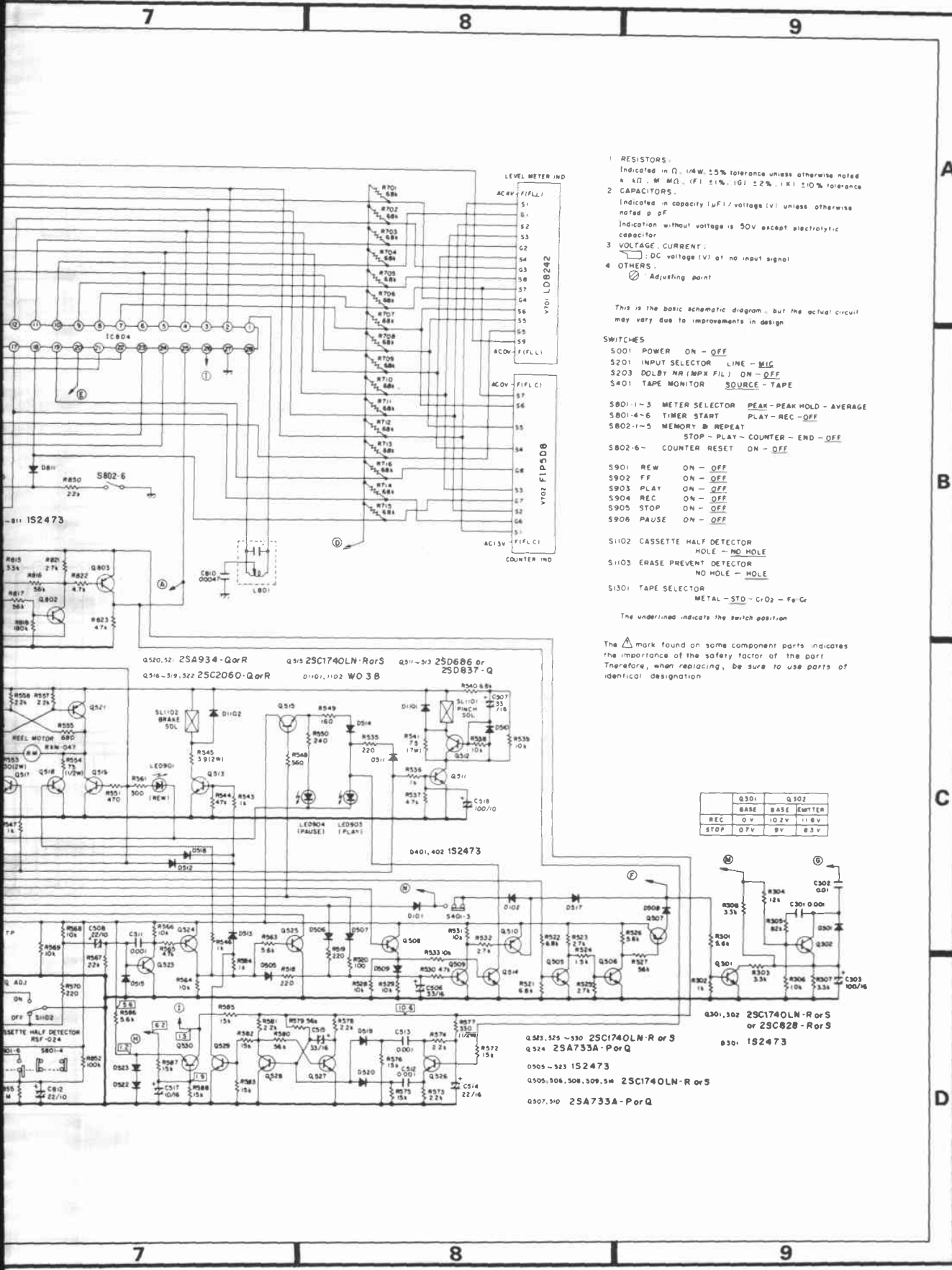

- 1 RESISTORS:
Indicated in Ω , 1/4W, 5% tolerance unless otherwise noted
k Ω , M Ω , (F) 5%, (G) 2%, (K) 10% tolerance
- 2 CAPACITORS:
Indicated in capacity (μ F) / voltage (V) unless otherwise noted
Indication without voltage is 50V except electrolytic capacitor
- 3 VOLTAGE, CURRENT:
DC voltage (V) or no input signal
- 4 OTHERS:
Adjusting point

This is the basic schematic diagram, but the actual circuit may vary due to improvements in design

- SWITCHES
- S001 POWER ON - OFF
 - S201 INPUT SELECTOR LINE - MIC
 - S203 DOLBY NR (MPX FIL) ON - OFF
 - S401 TAPE MONITOR SOURCE - TAPE
- S801-1-3 METER SELECTOR PEAK - PEAK HOLD - AVERAGE
S801-4-6 TIMER START PLAY - REC - OFF
S802-1-5 MEMORY & REPEAT STOP - PLAY - COUNTER - END - OFF
S802-6- COUNTER RESET ON - OFF
- S901 REW ON - OFF
 - S902 FF ON - OFF
 - S903 PLAY ON - OFF
 - S904 REC ON - OFF
 - S905 STOP ON - OFF
 - S906 PAUSE ON - OFF

- S1102 CASSETTE HALF DETECTOR HOLE - NO HOLE
- S1103 ERASE PREVENT DETECTOR NO HOLE - HOLE
- S1301 TAPE SELECTOR METAL - STD - CrO₂ - FeCr

The underlined indicates the switch position

The Δ mark found on some component parts indicates the importance of the safety factor of the part. Therefore, when replacing, be sure to use parts of identical designation

	Q301	Q302
BASE	0.7V	1.1V
EMITTER	0.7V	0.3V

- Q501, 502 2SA934-Q or R
- Q503 25C1740LN-R or S
- Q504 25D686 or 25D837-Q
- Q505, 506, 508, 509, 510 25C2060-Q or R
- D1101, 1102 WO 3 B
- Q301, 302 29C1740LN-R or S or 29C828-R or S
- Q303 1S2473
- Q505, 506, 508, 509, 510 25C1740LN-R or S
- Q507, 510 2SA733A-P or Q

A

B

C

D

Appearance of Transistors and ICs

2SA733A

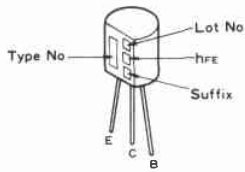

PA4005
μPD4050C

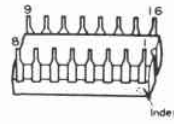

2SA934
2SC2060

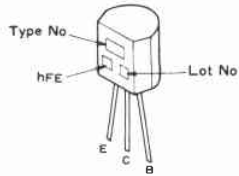

PD4004

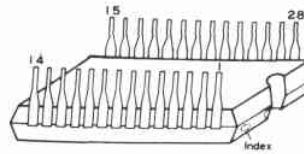

2SC828
2SC1327

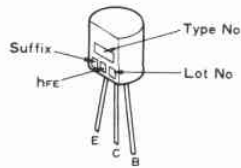

μPC324C

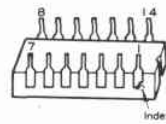

2SC1740LN

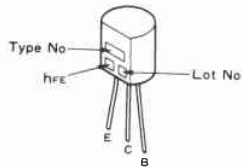

TC9121P

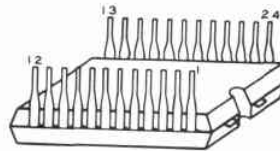

2SD686

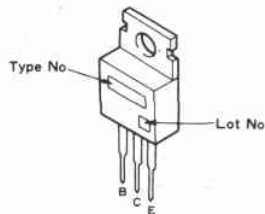

TA7318P

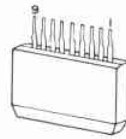

2SD837

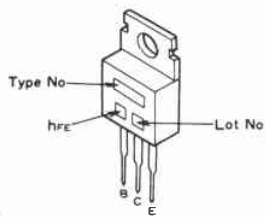

AN370

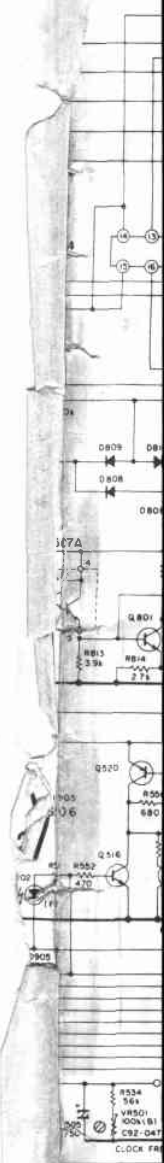

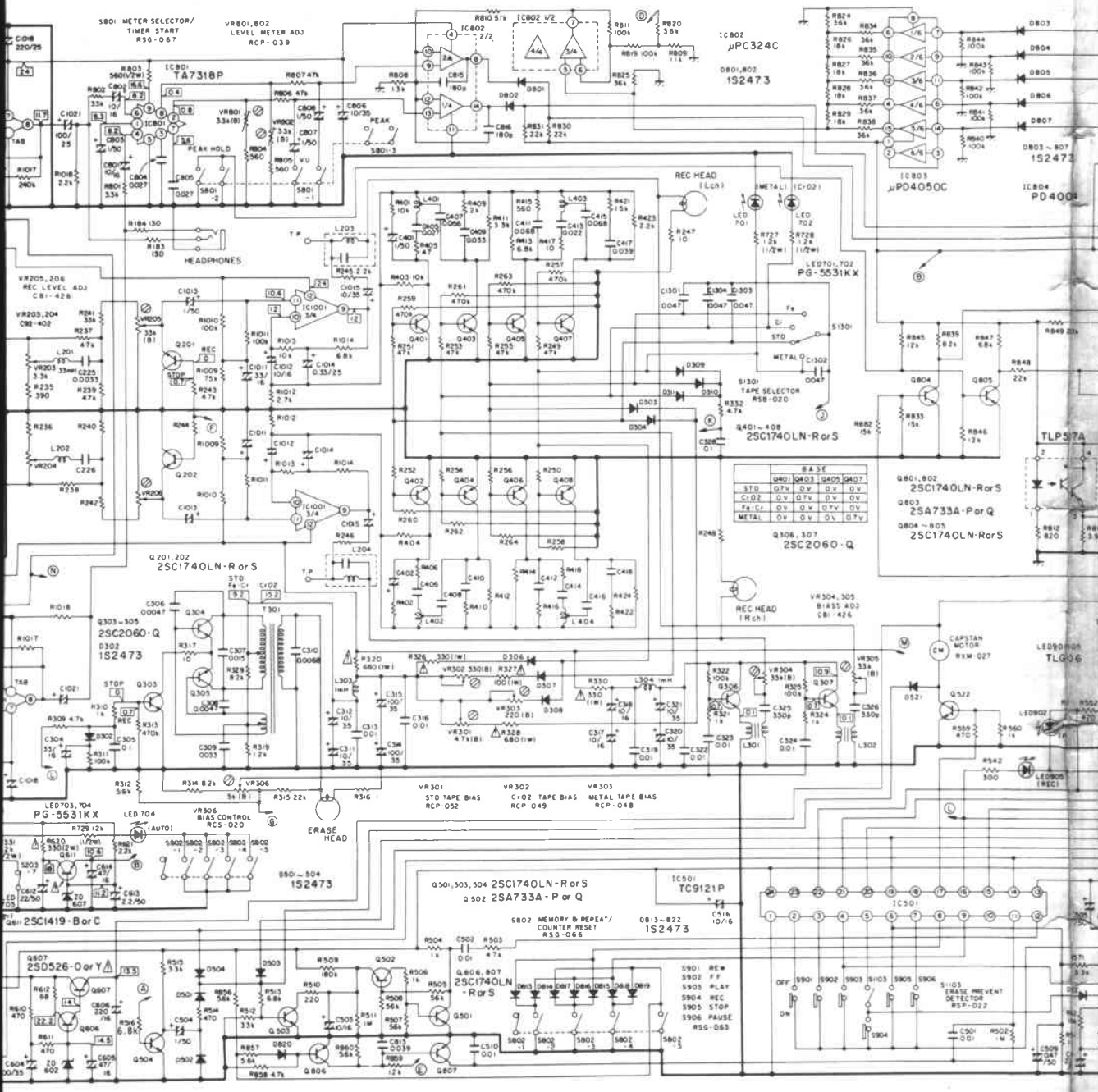

12.3 SCHEMATIC DIAGRAM

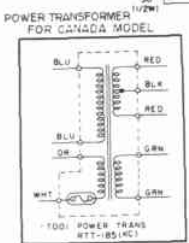
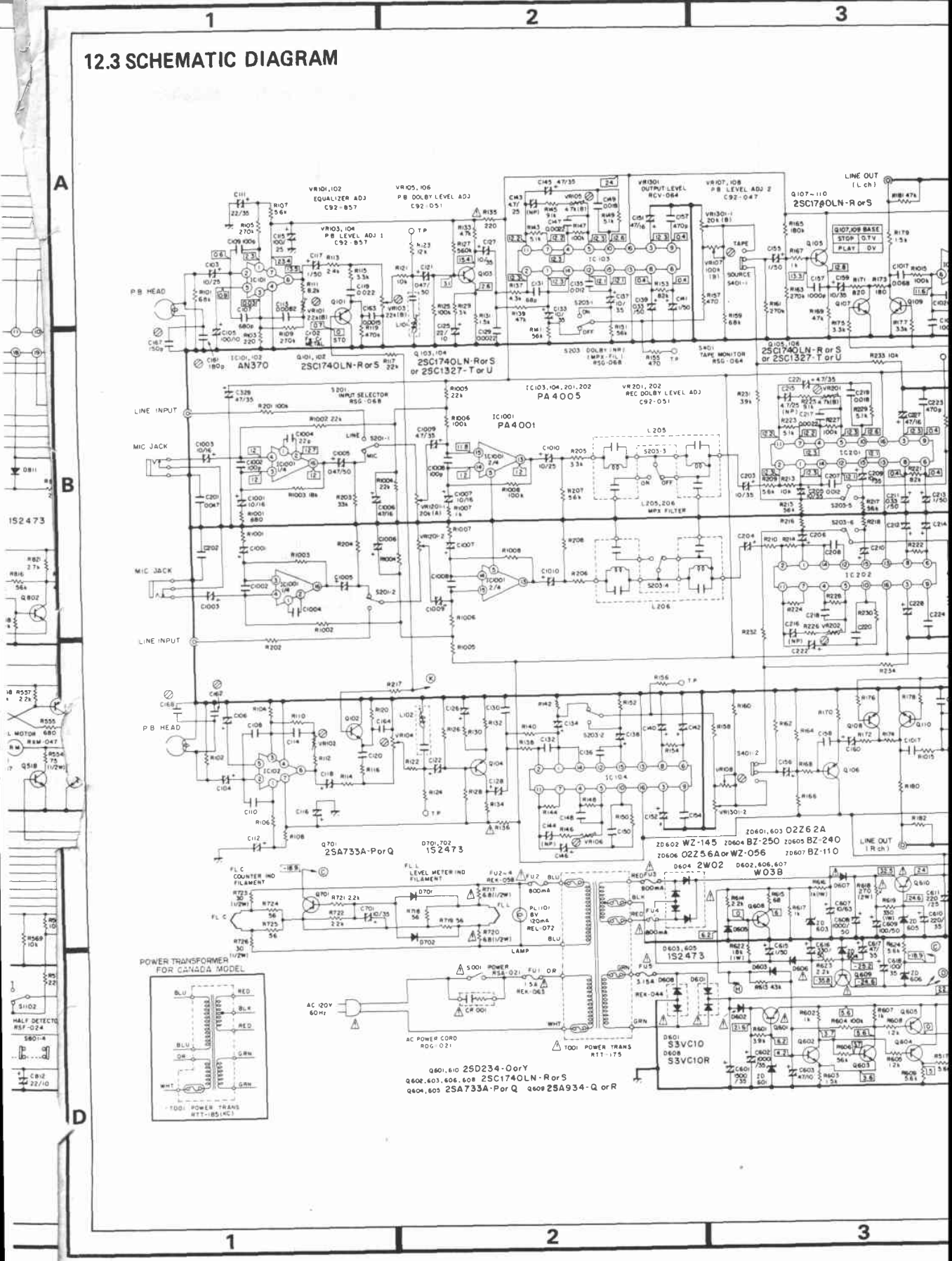

601,610 2SD234-0orY
 606,603,606,608 2SC1740LN-R or S
 604,605 2SA733A-Par Q 609 2SA934-Q or R

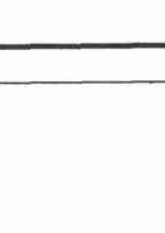
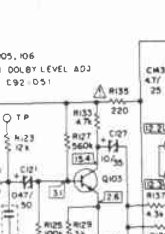
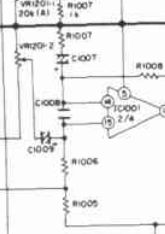
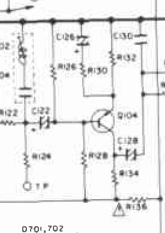
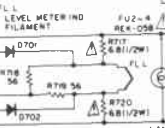
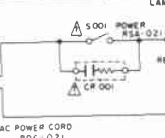

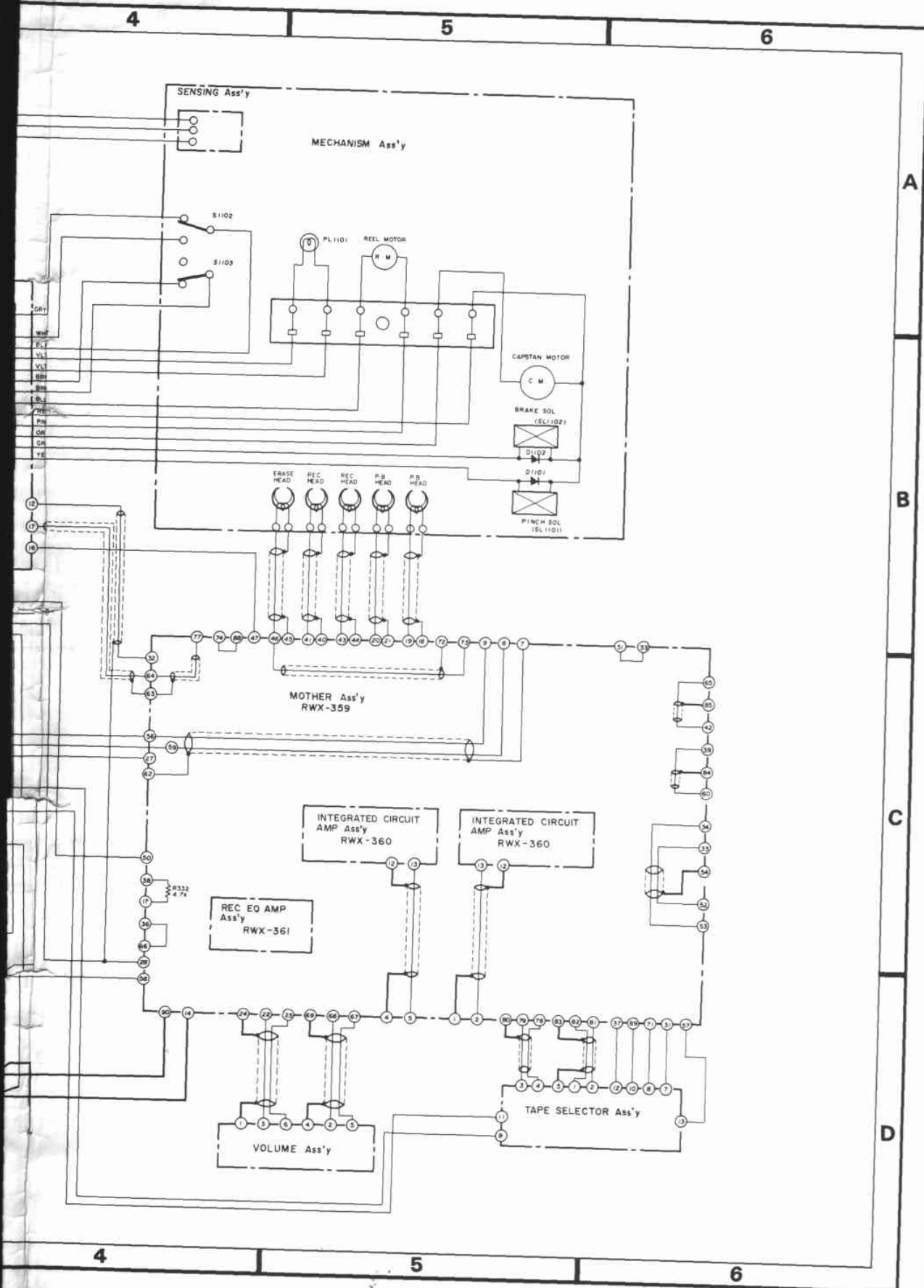

Appearance of Transistors and ICs

2SA733A

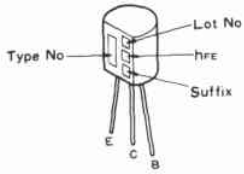

PA4005
μPD4050C

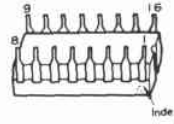

2SA934
2SC2060

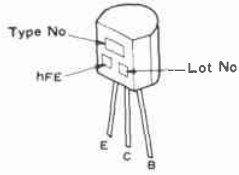

PD4004

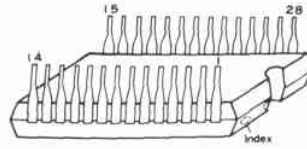

2SC828
2SC1327

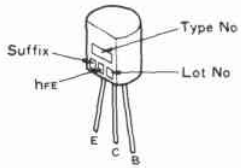

μPC324C

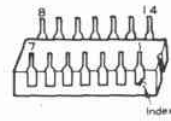

2SC1740LN

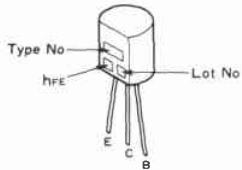

TC9121P

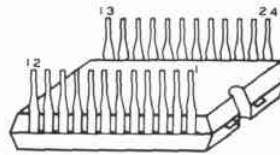

2SD686

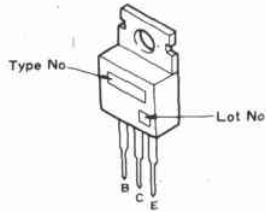

TA7318P



2SD837

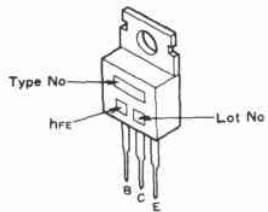

AN370



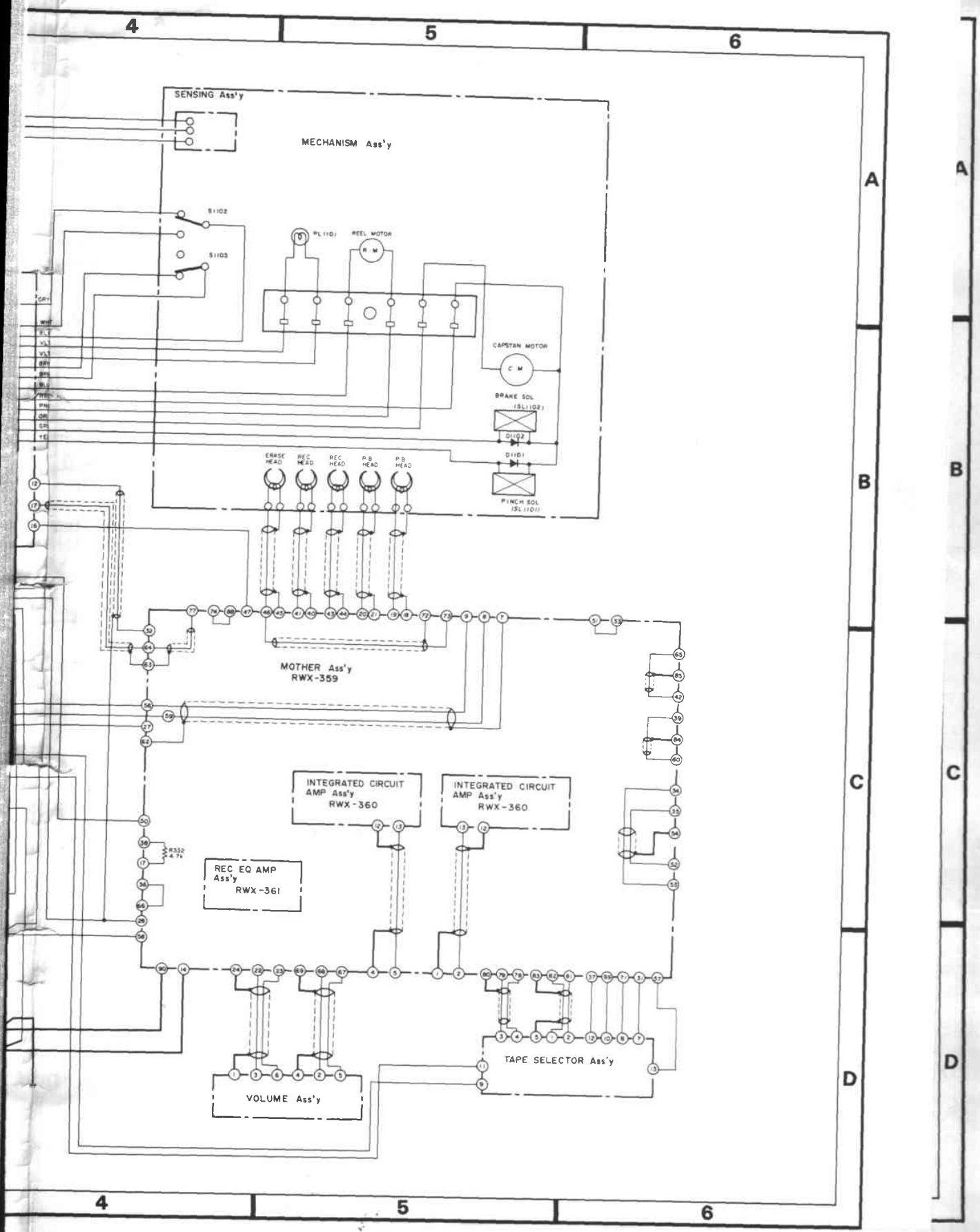

12.2 CONNECTION DIAGRAM

A
B
C
D

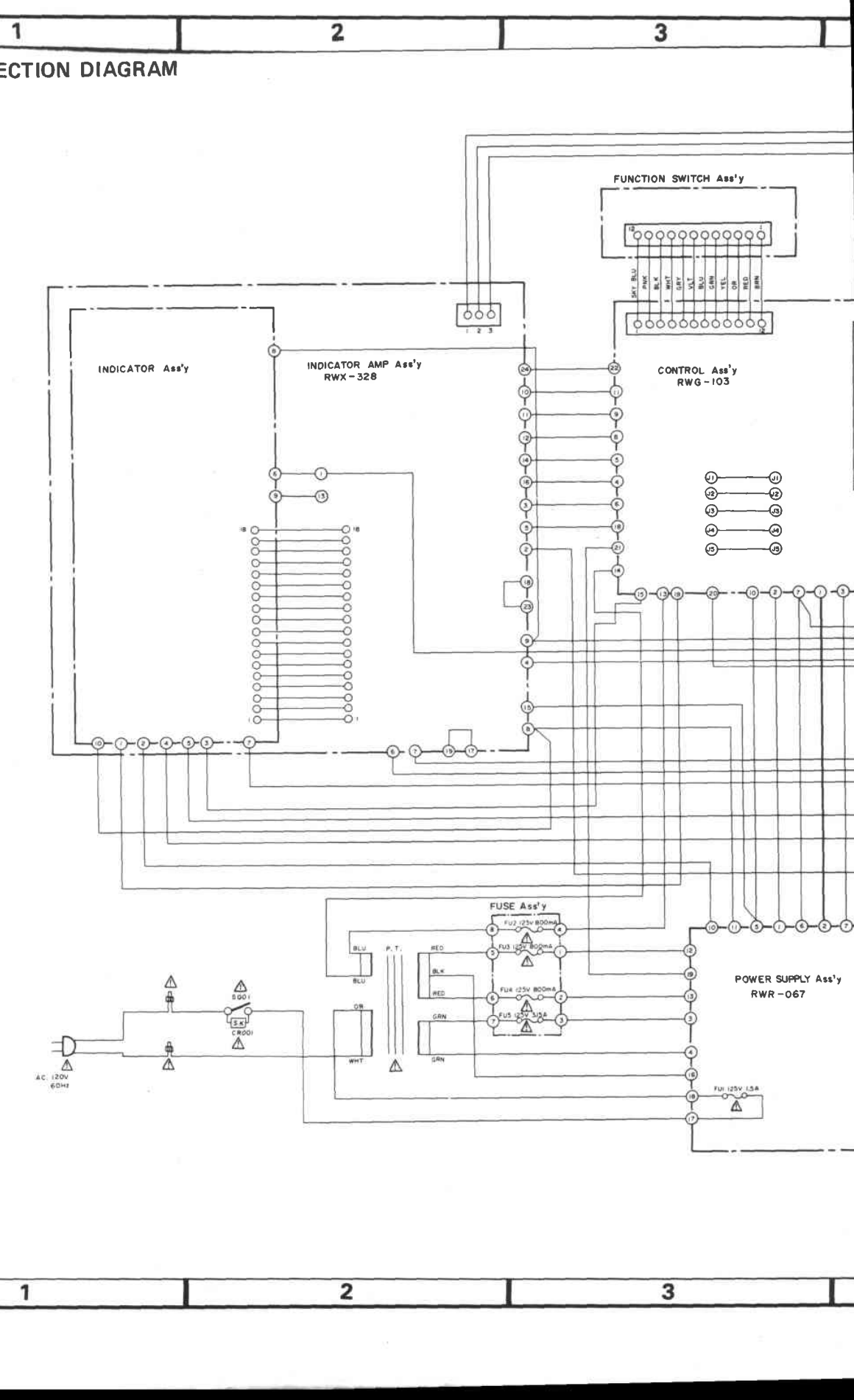

.5 MOTHER ASSEMBLY (RWX-359)

Parts List

ASSEMBLIES

Part No.	Symbol & Description
RWX-360	Integrated amplifier assembly
RWX-361	REC EQ assembly

SWITCHES

Part No.	Symbol & Description
RSG-068	S201, S203 Push switch (DOLBY NR INPUT)
RSG-064	S401 Push switch (MONITOR)

COILS

Part No.	Symbol & Description
RTF-058	L101, L102 Trap coil
RTF-033	L201, L202 Trap coil
RTF-055	L203, L204 Trap coil
RTF-040	L205, L206 MPX filter brock
RTD-018	L301, L302 Matching transformer
RTF-057	L303, L304 Line coil
T64-001	T301 OSC coil

CAPACITORS

Part No.	Symbol & Description
CEANL 100P 25	C103, C104
CEA 101P 25	C115, C116, C314, C315, C320, C321
CEA 101P 16	C303
CEA 101P 10	C105, C106
CEA 470P 35	C328
CEA 470P 16	C151, C152, C227, C228
CEA 220P 10	C125, C126
CEA 100P 35	C127, C128, C133, C134, C137, C138, C159, C160, C203-C206, C209, C210, C311, C312
CEA 4R7P 35	C145, C146, C221, C222
CEA 010P 50	C117, C118, C155, C156, C305
CEA 010M 50	C141, C142, C213, C214
CEA R47P 50	C121, C122
CEA R33M 50	C139, C140, C211, C212
CEA 220P 35	C111, C112
CEA 330P 16	C304
CEA 100P 16	C317, C318, C229, C230-C232
CEA 4R7M 25NP	C143, C144, C215, C216
CQMA 104K 50	C328
CQMA 333K 50	C309
CQMA 223K 50	C119, C120
CQMA 183K 50	C149, C150, C219, C220
CQMA 153K 50	C307
CQMA 123K 50	C135, C136, C207, C208
CQMA 103K 50	C302, C323, C324
CQMA 682K 50	C310

Part No.	Symbol & Description
CQMA 822K 50	C113, C114
CQMA 472K 50	C306, C308
CQMA 332K 50	C225, C226
CQMA 222K 50	C129, C130, C147, C148, C217, C218
CQMA 102K 50	C301, C165, C166
CQMA 152K 50	C163, C164
RCE-023	C131, C132
RCE-008	C325, C326
RCE-025	C161, C162
CCDSL 101K 50	C109, C110
CKDYB 681K 50	C107, C108
CKDYB 471K 50	C153, C154, C223, C224
CKDYF 473Z 50	C201, C202, C327
CKDYF 103Z 50	C313, C316, C319, C322
CKDYF 108Z 50	C157, C158

Note: When ordering resistors, convert the resistance value into code form, and then rewrite the part no. as before.

RESISTORS

Part No.	Symbol & Description
C92-857	VR101-VR104 Semi-fixed 22K-B
C92-051	VR105, VR106, VR201, VR202 Semi-fixed 4R7K-B
C92-047	VR107, VR108 Semi-fixed 100K-B
C92-402	VR203, VR204 Semi-fixed 3R3K-B
C81-426	VR205, VR206, VR304, VR305 Semi-fixed 33K-B
RCP-052	VR301 Semi-fixed 4.7K-B
RCP-049	VR302 Semi-fixed 330-B
RCP-048	VR303 Semi-fixed 220-B
RCS-020	VR306 Volume 5K-B (BIAS)
RD $\frac{1}{2}$ PM $\square\square\square$ J	R101-R134, R137-R184, R201-R264, R301-R317, R319, R321, R322, R324, R325, R329, R332
RD $\frac{1}{2}$ PF 221J	R135, R136
RD $\frac{1}{2}$ PF 122J	R331
RS1PF $\square\square\square$ J	R320, R326-R328, R330

SEMICONDUCTORS

Part No.	Symbol & Description
AN370	IC101, IC102
PA4005	IC103, IC104, IC201, IC202
2SC1740LN	Q101, Q102, Q107-Q110, Q201, Q202
2SC1740LN (2SC1327)	Q103-Q106
2SC1740LN (2SC828)	Q301, Q302
2SC2060-Q	Q303-Q307
1S2473-T	D101, D102, D301-D304, D306-D311

OTHERS

Part No.	Symbol & Description
RKB-014 (RKB-016)	4P mount pinjack
RKN-044	MIC jack
RKN-046	Headphone jack
RBF-042	Ceramic tube
RBF-041	Ceramic tube

12.4 FUNCTION SWITCH ASSEMBLY

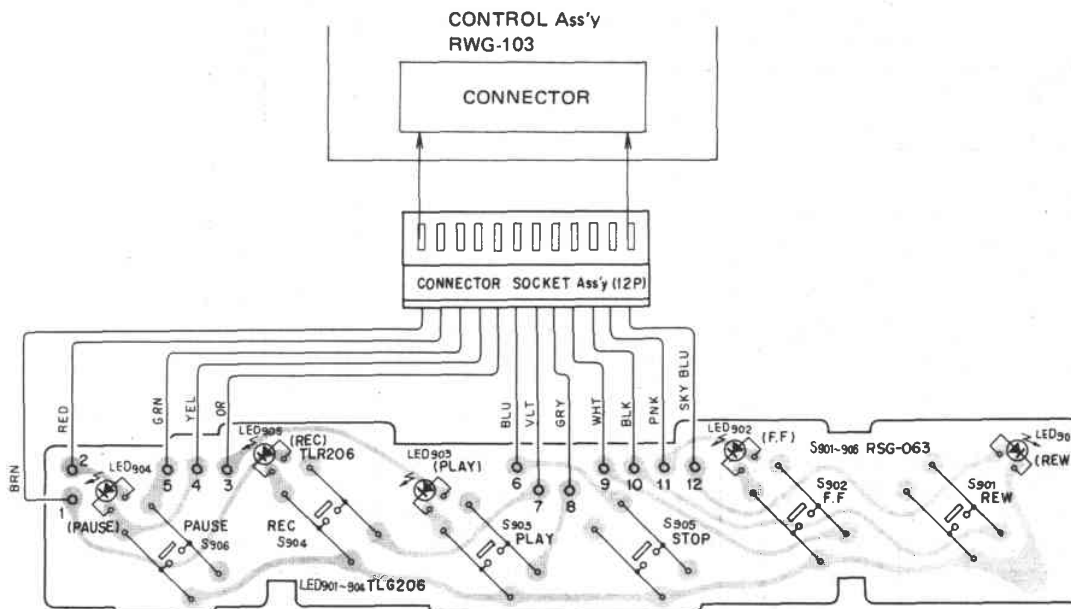
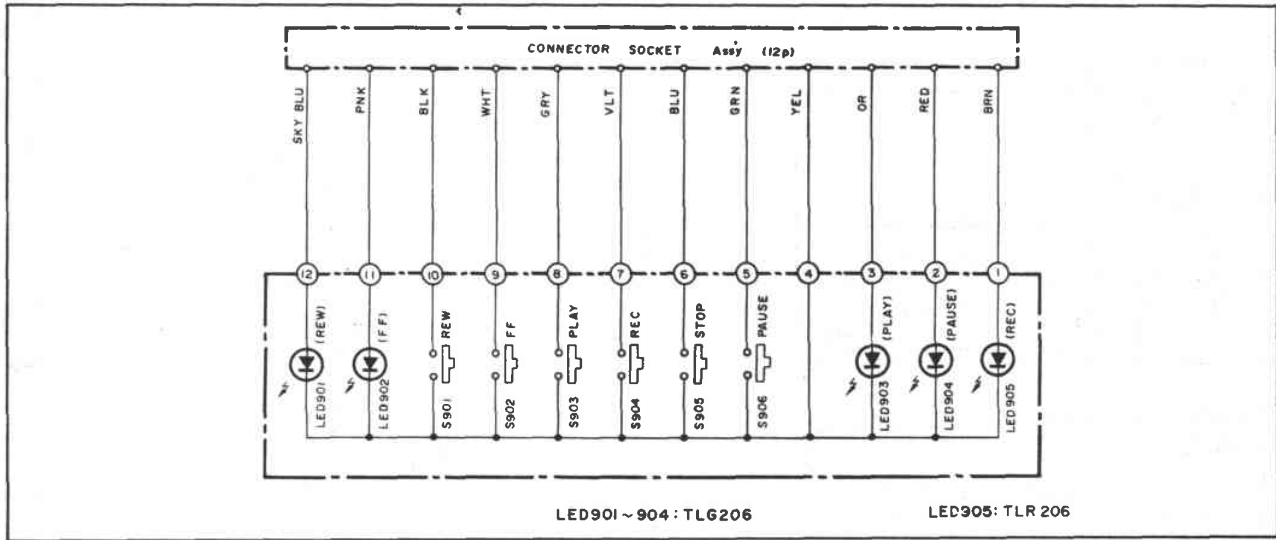

Parts List

SWITCHES

Part No.	Symbol & Description
RSG-063	S901-S906 Function switch

SEMICONDUCTORS

Part No.	Symbol & Description
TLG 206	LED901-LED904
TLR 206	LED905

OTHERS

Part No.	Symbol & Description
RKP-042	Connector socket assembly (12P)
RNK-733	LED holder

Mother Assembly (RWX-359)

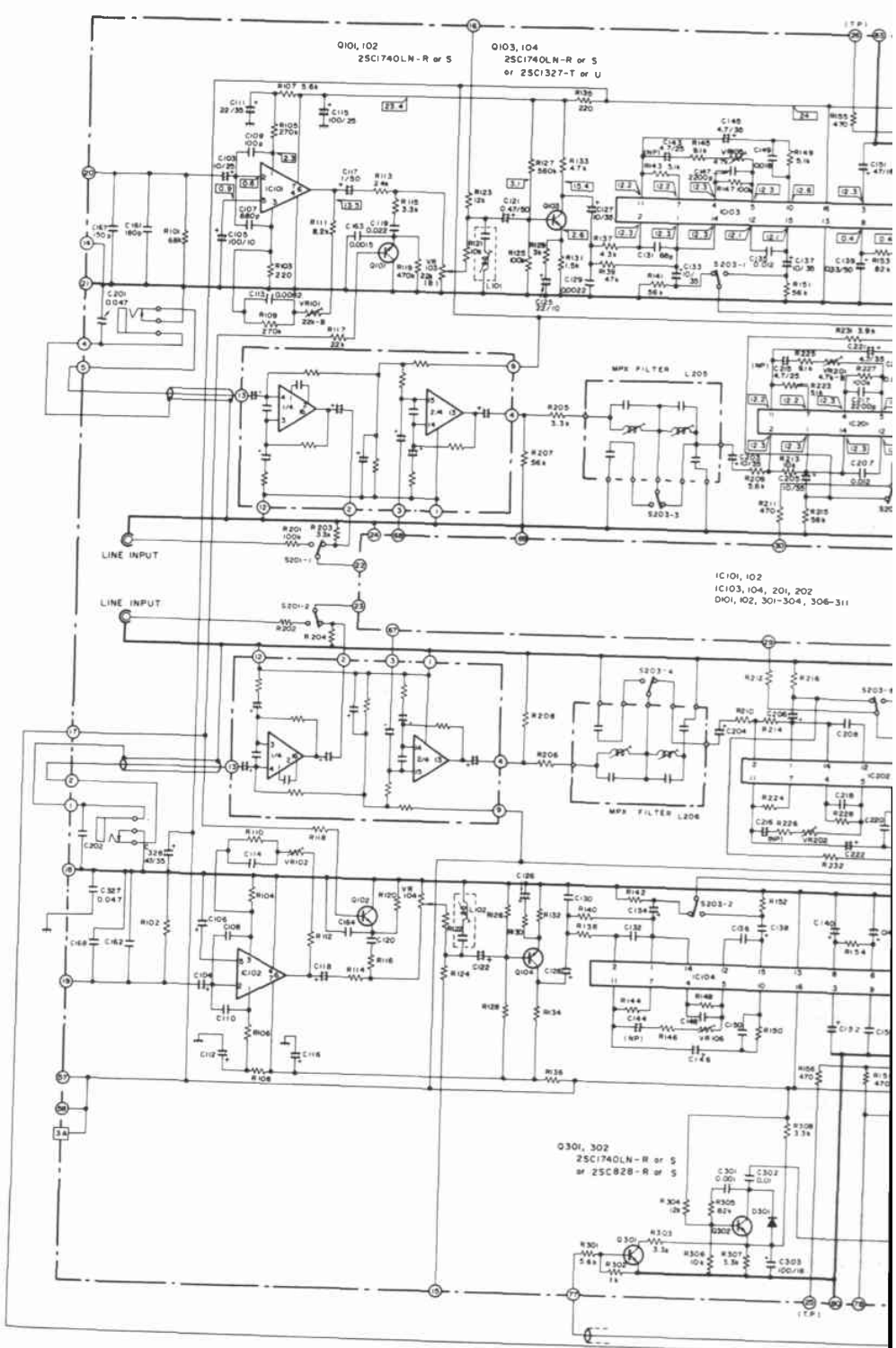

S201-1-2 INPUT SW
 S203-1-7 DOLBY NR
 S401-1-3 MONITOR

12

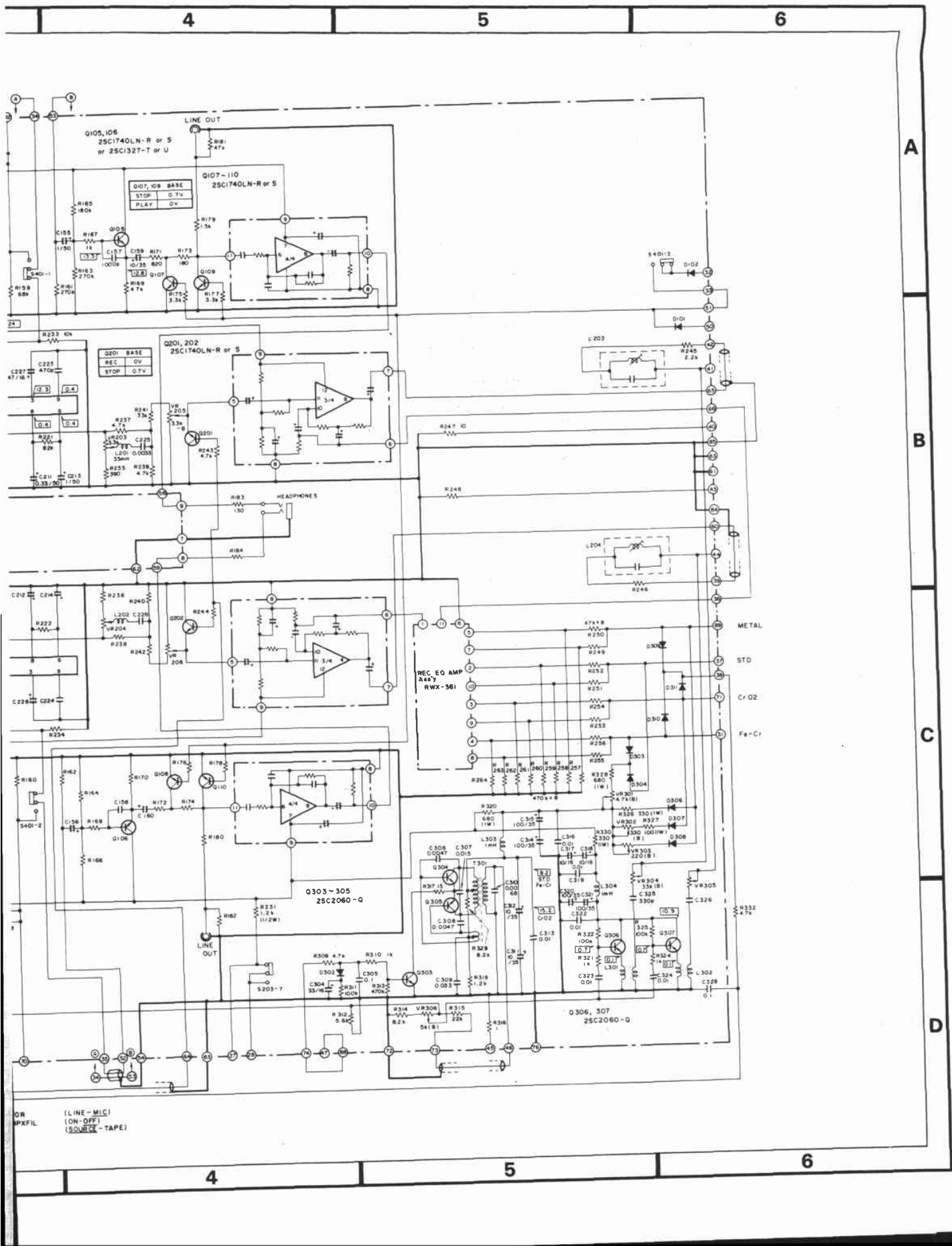

Mother Assembly (RWX-359)

12

A

B

C

D

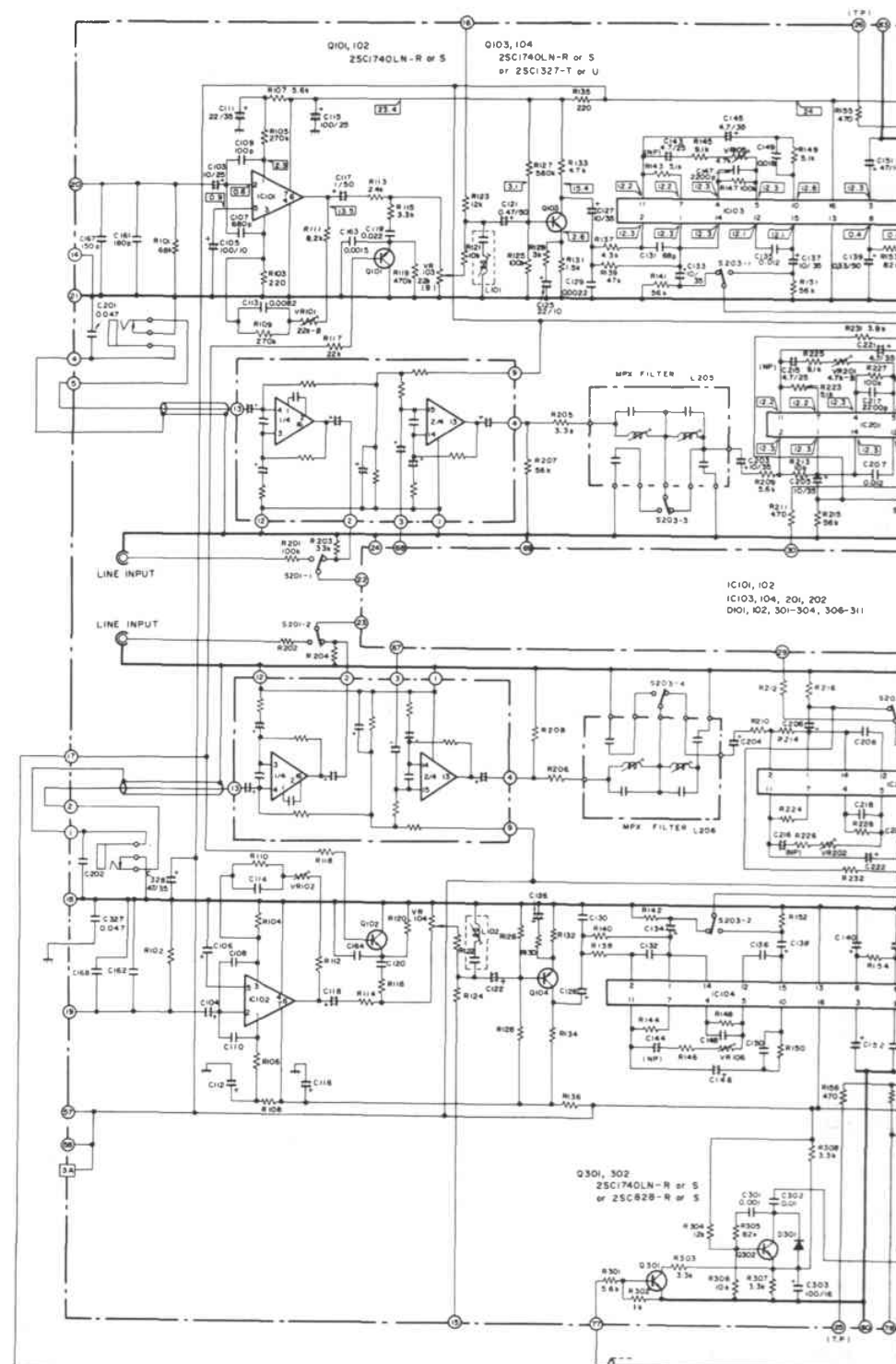

IC101, 102
IC103, 104, 201, 202
IC101, 102, 301-304, 306-311

Q301, 302
25C1740LN-R or S
or 25C828-R or S

S201-1-2 INPU
S203-1-7 DOLB
S401-1-3 MONI

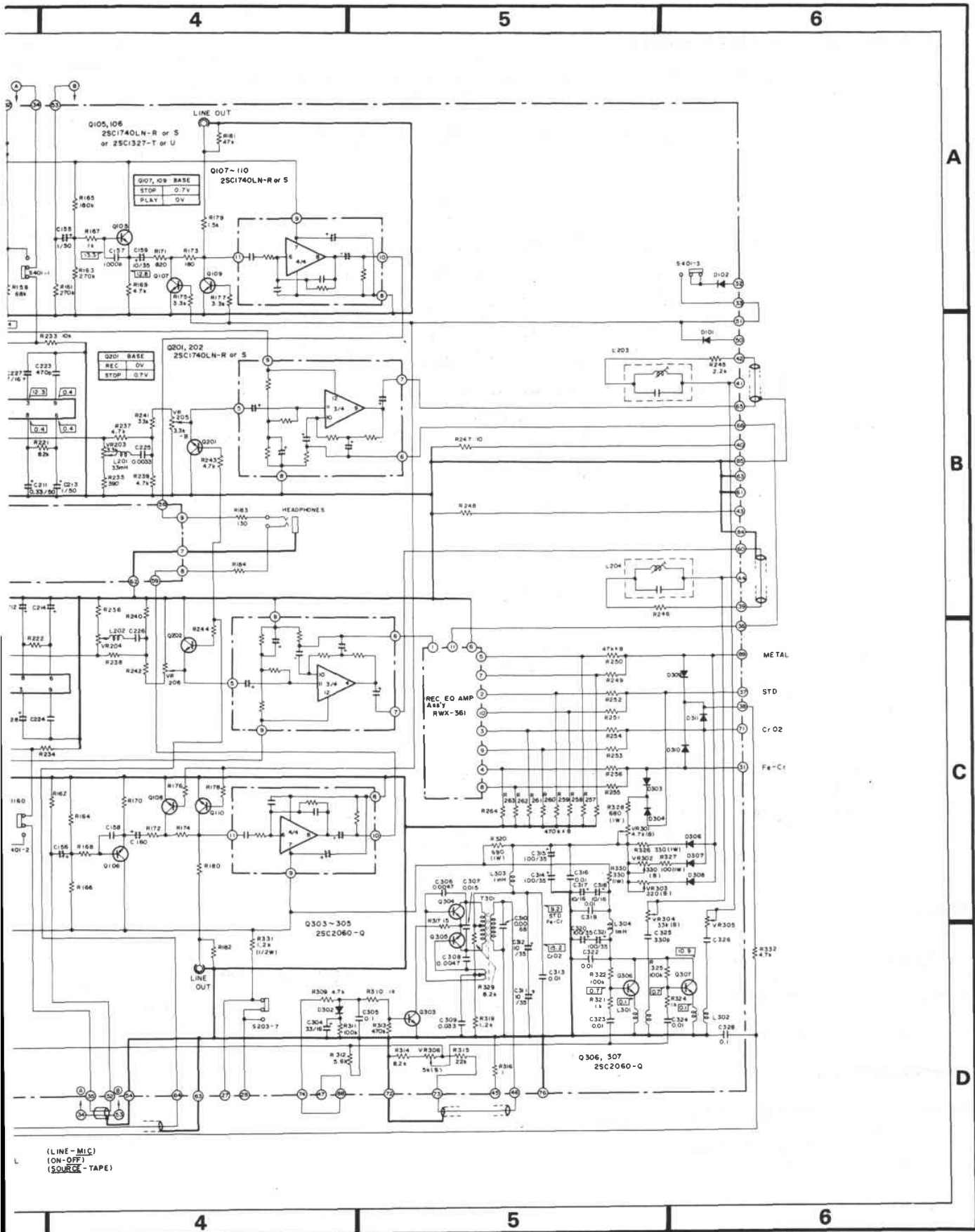

12.8 INDICATOR ASSEMBLY

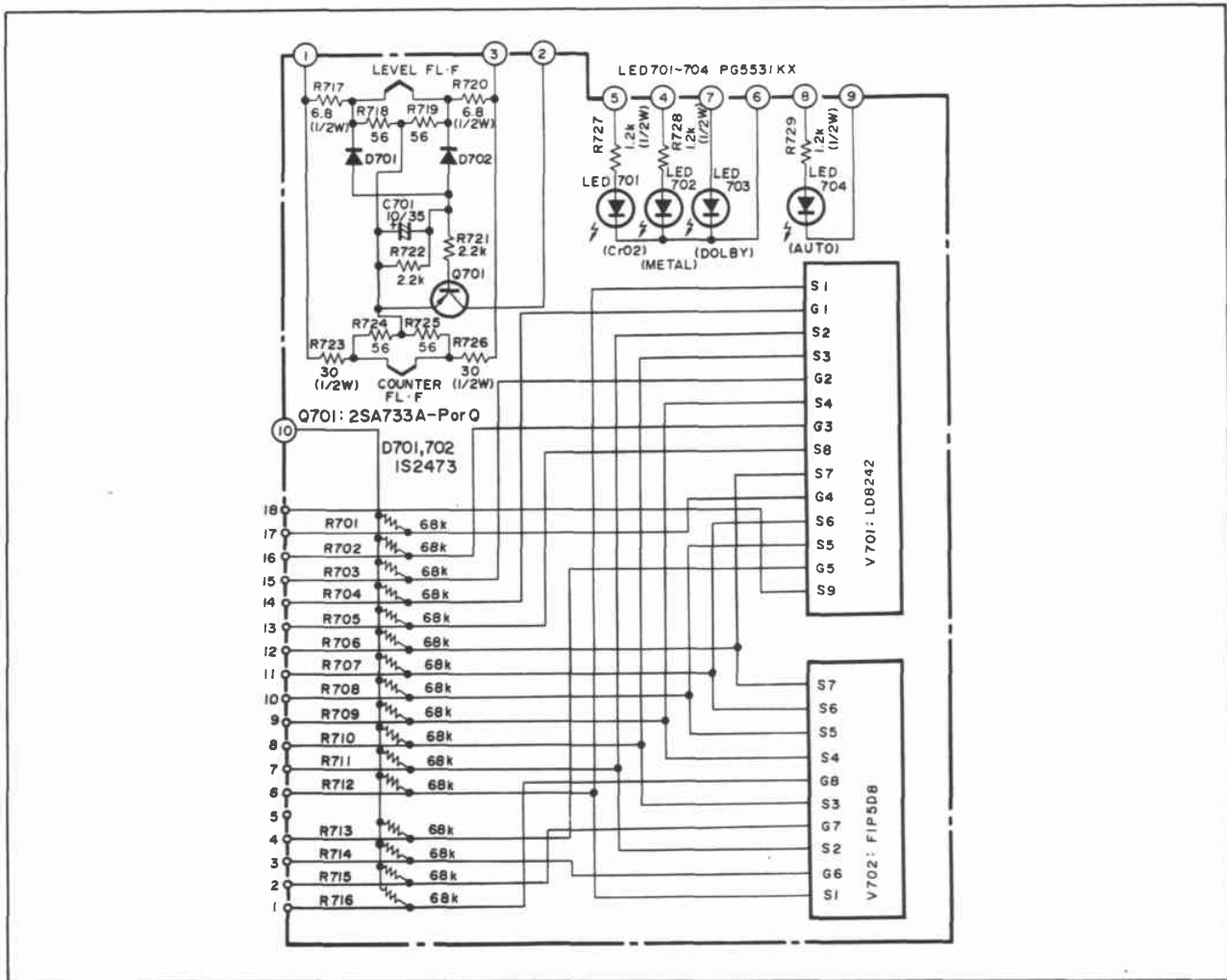

Parts List

CAPACITOR

Part No.	Symbol & Description
CEA 100P 35	C701

Note: When ordering resistors, convert the resistance value into code form, and then rewrite the part no. as before.

RESISTORS

Part No.	Symbol & Description
RD $\frac{1}{2}$ PM $\square\square\square$ J	R701-R716, R718, R719, R721, R722, R724, R725
RD $\frac{1}{2}$ PF 122J	R727-R729
RS $\frac{1}{2}$ PF $\square\square\square$ J	R717, R720, R723, R726

SEMICONDUCTORS

Part No.	Symbol & Description
2SA733A	Q701
1S2473	D701, D702
PG5531KX	LED701-LED704

OTHERS

Part No.	Symbol & Description
LD8242	V701 Fluorescent indicator tube (LEVEL)
FIP5D8	V702 Fluorescent indicator tube (COUNTER)
RDD-001	Cord (18P)

12.6 VOLUME ASSEMBLY

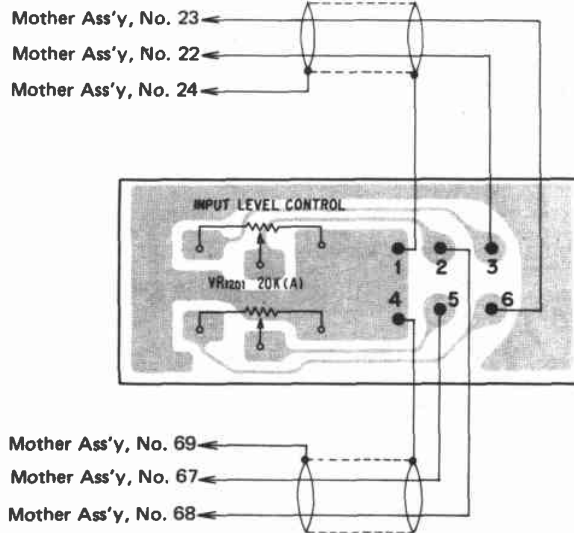
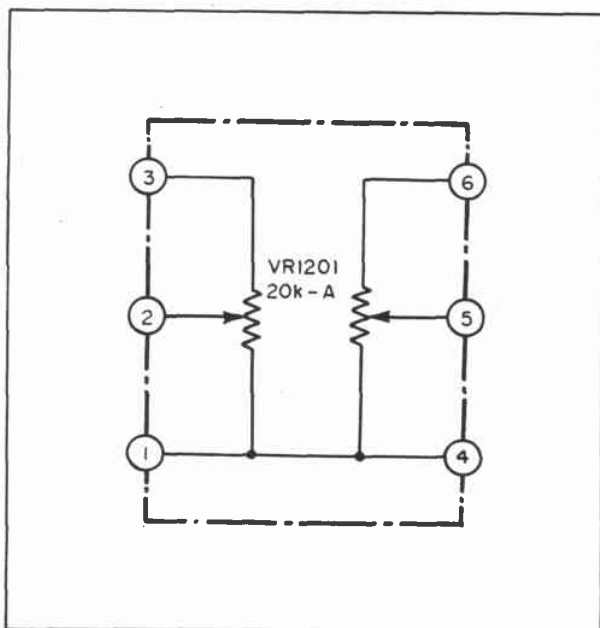

Parts List

Part No.	Symbol & Description
RCV-056	VR1201 Volume 20k(A) (INPUT)

12.7 SENSING ASSEMBLY

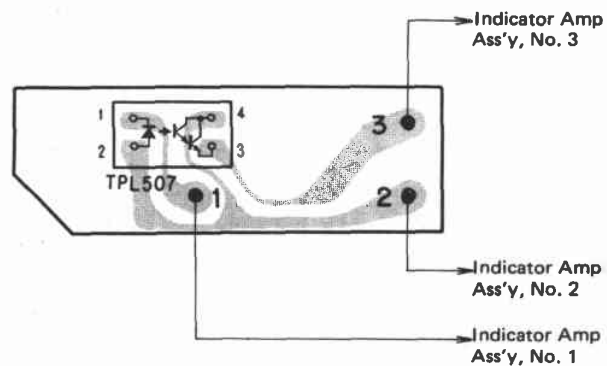
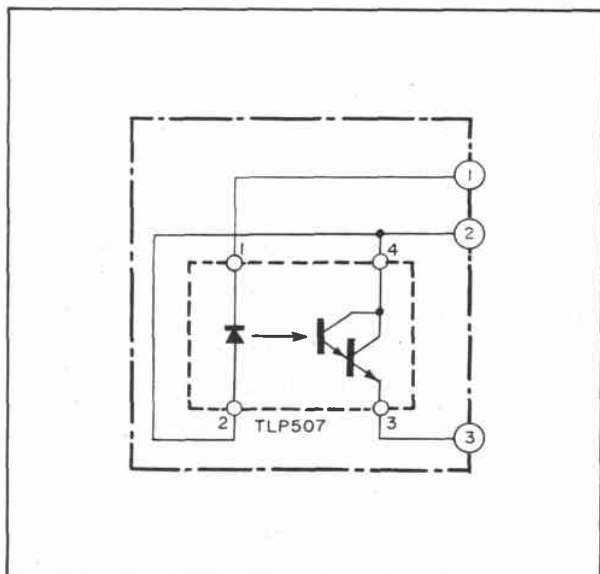

Parts List

Part No.	Symbol & Description
TLP 507A	Photo interrupter

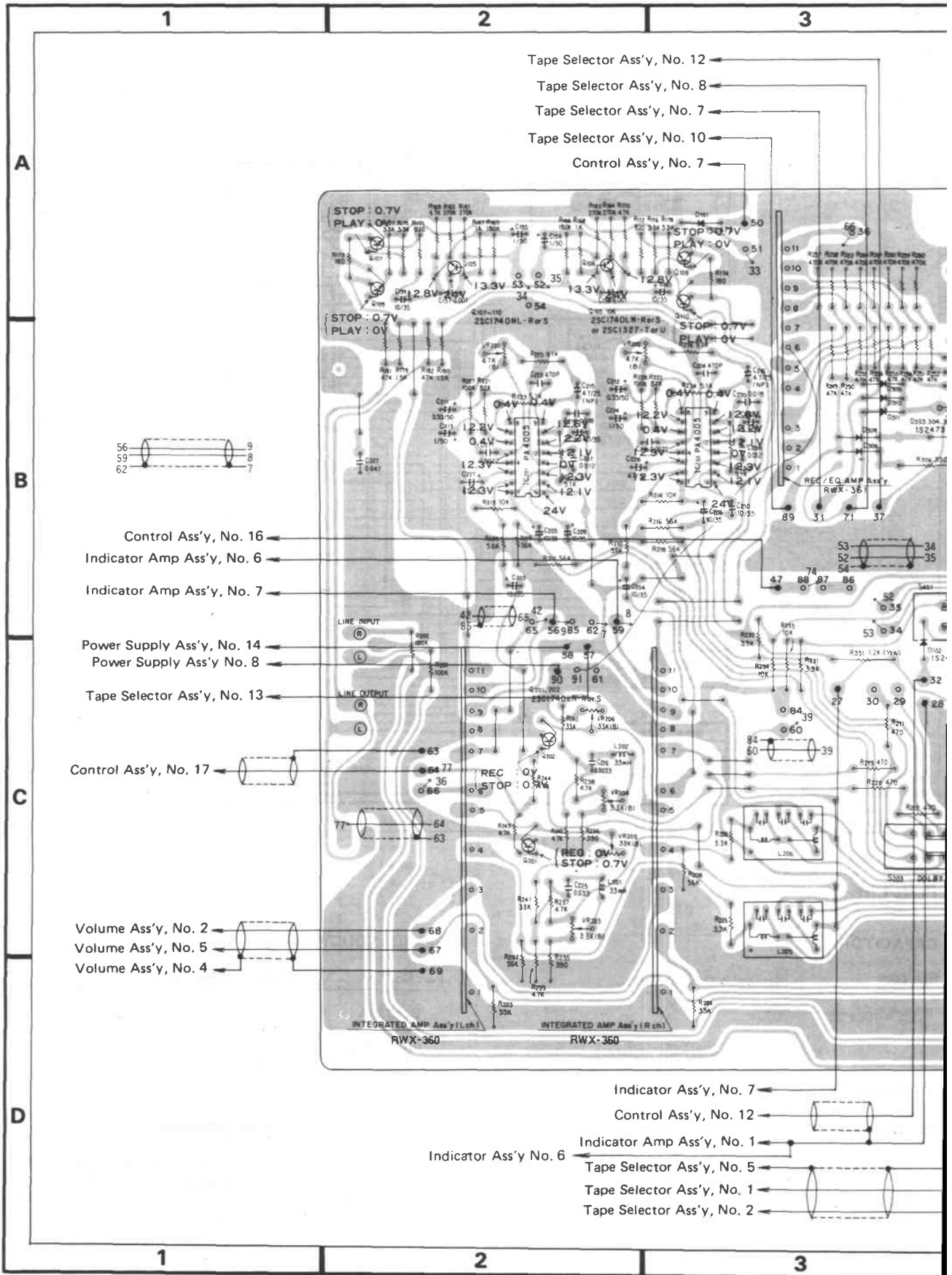

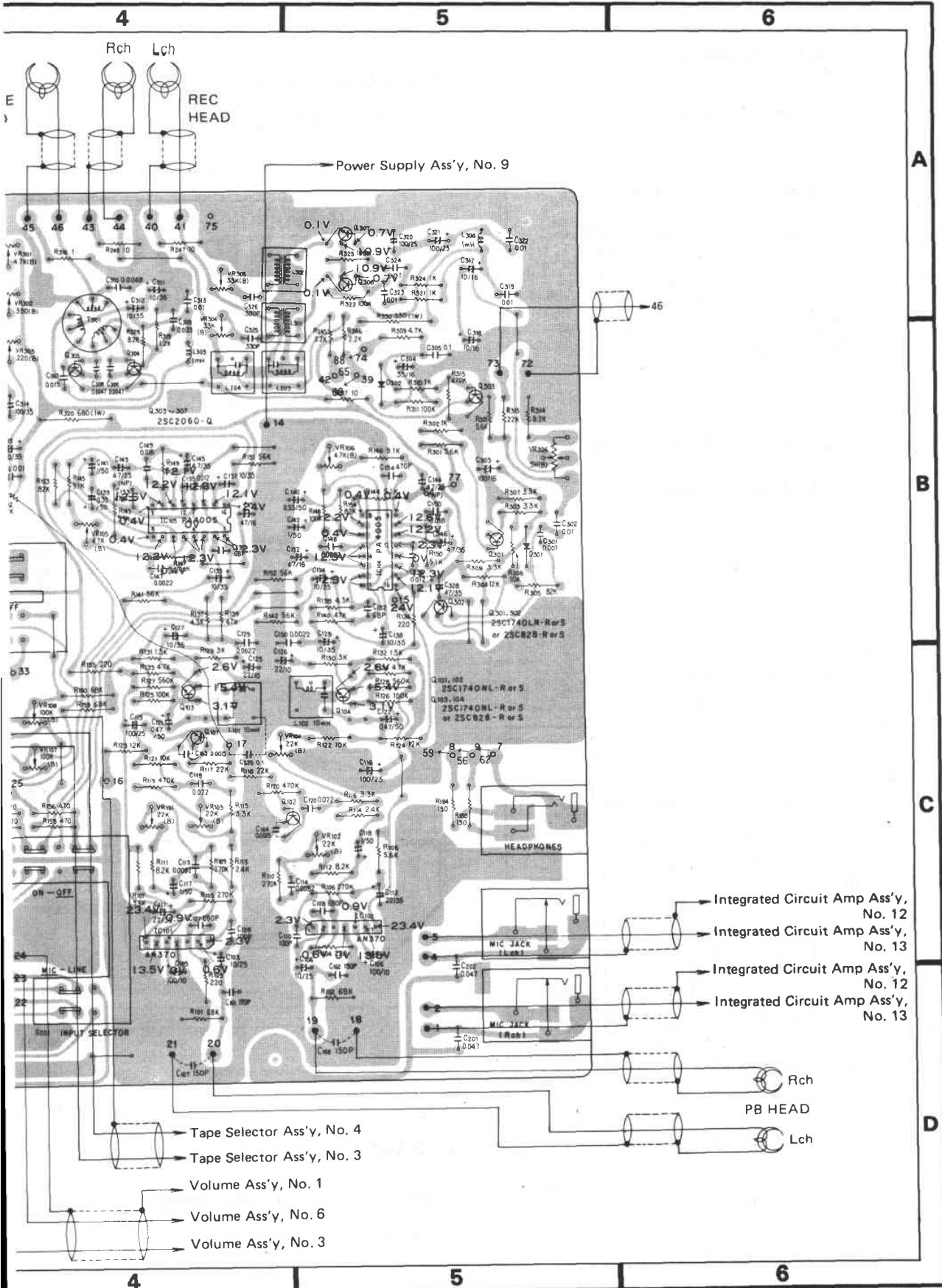

A

B

C

D

12.9 INDICATOR AMPLIFIER ASSEMBLY (RWX-328)

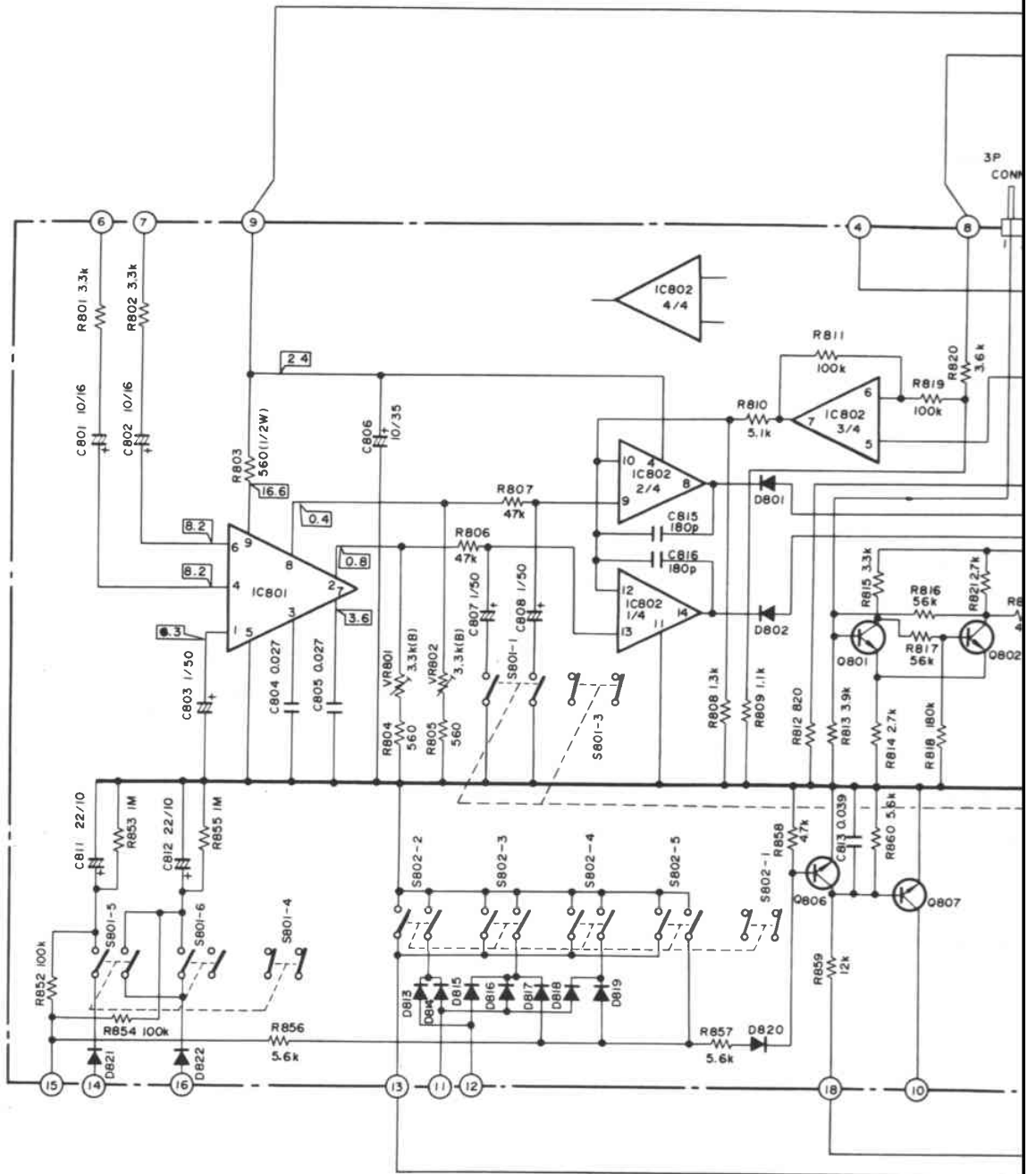

IC801 : TA7318P
 IC802 : μ PC 324C
 IC803 : μ PD4050C
 IC804 : PD4004

S801-1-3 : METER FUNCTION (AVERAGE, PEAKHOLD, PEAK)
 S801-4~6 : TIMER REC/PLAY (OFF, REC/PLAY, PLAY)
 S802-1-5 : MEMORY & REPEAT (OFF, ENDREPEAT, COUNTERREPEAT, MEMORY PLAY, M...)
 S802-6 : COUNTER RESET

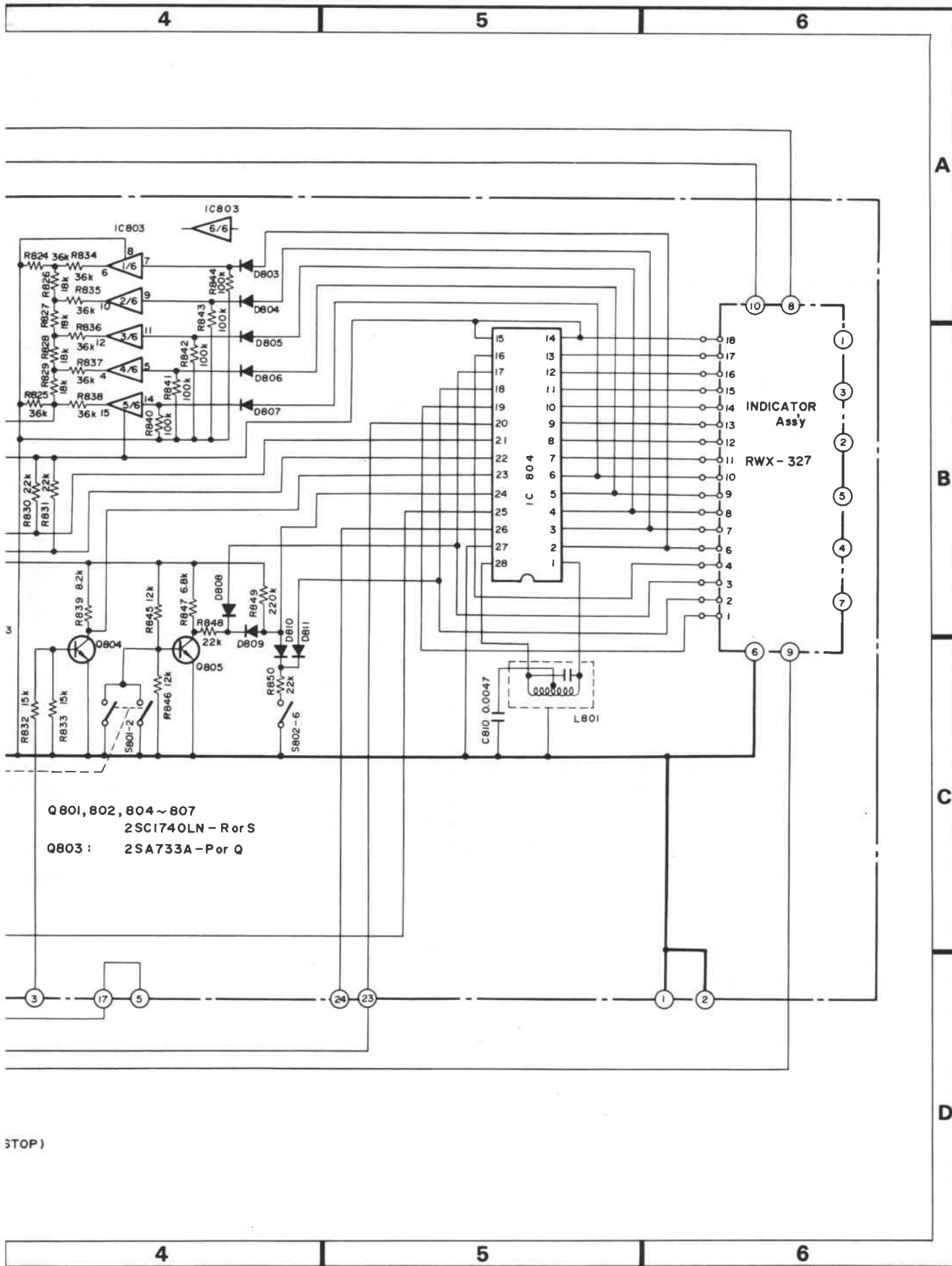

Q801, 802, 804~807
2SC1740LN - R or S
Q803 : 2SA733A - P or Q

STOP)

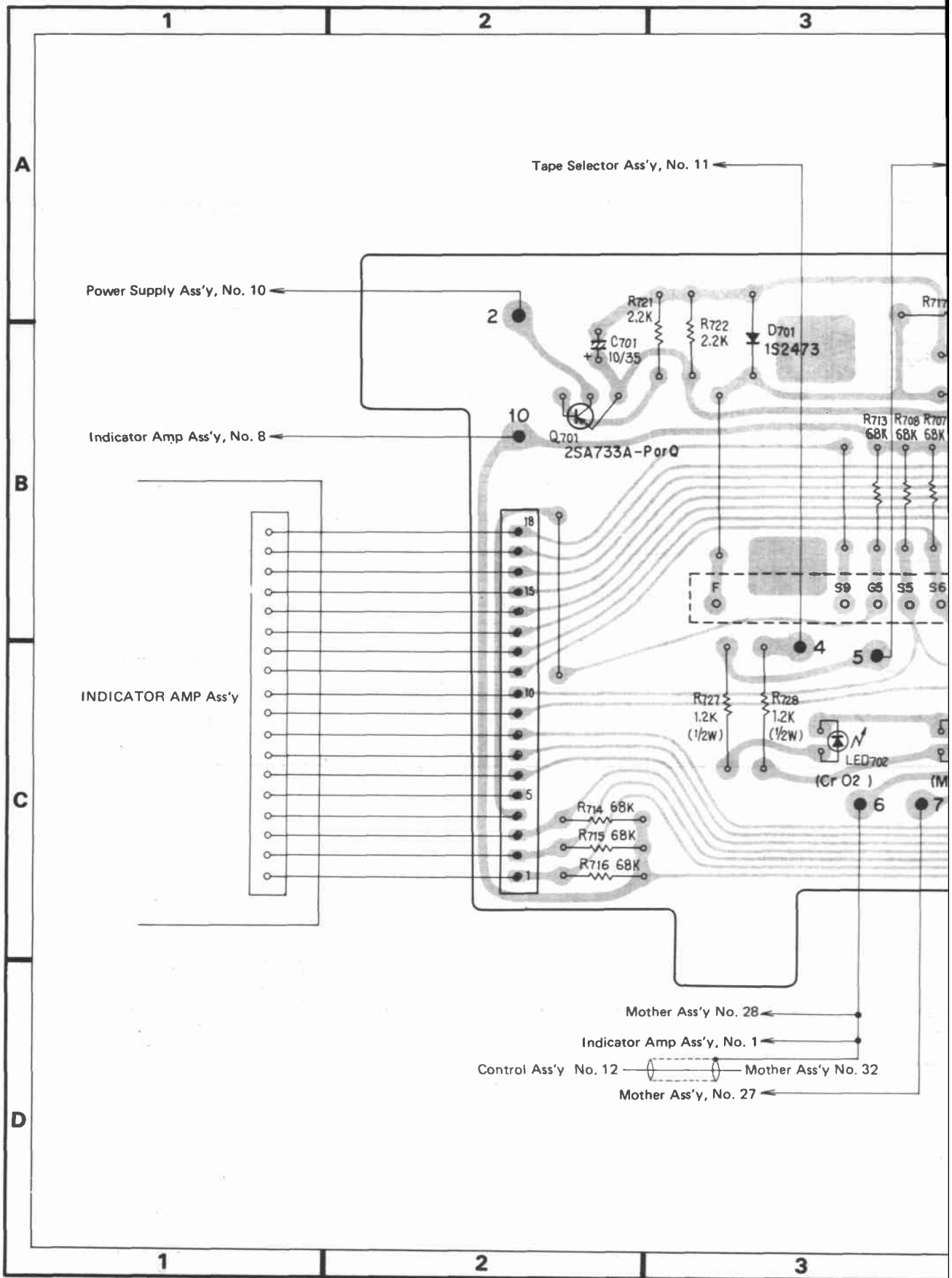

Mother Ass'y No. 28 ←
 Indicator Amp Ass'y, No. 1 ←
 Control Ass'y No. 12 ← Mother Ass'y No. 32 ←
 Mother Ass'y, No. 27 ←

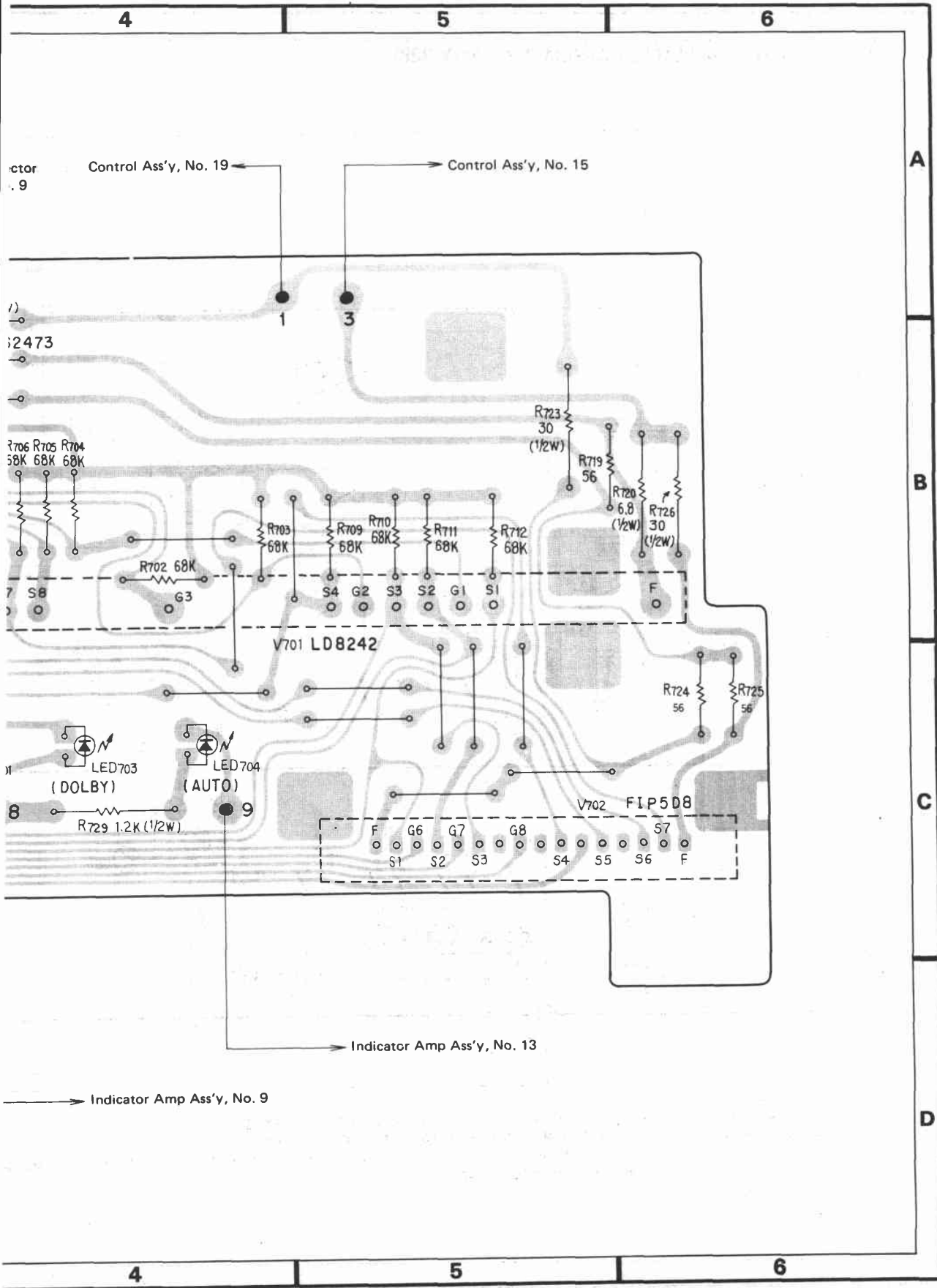

Parts List of Indicator Amplifier Assembly (RWX-328)

SWITCHES AND COIL

Part No.	Symbol & Description
RSG-067	S801 Switch F
RSG-066	S802 Switch E
RTD-015	L801 Oscillation coil

CAPACITORS

Part No.	Symbol & Description
CEA 100P 16	C801, C802
CEA 100P 35	C806
CEA 220P 10	C811, C812
CEA 010P 50	C803, C807, C808
CQMA 273K 50	C804, C805
CQMA 393K 50	C813
CQMA 472K 50	C810
CCDSL 181K 50	C815, C816

Note: When ordering resistors, convert the resistance value into code form, and then rewrite the part no. as before.

RESISTORS

Part No.	Symbol & Description
RCP-039	VR801, VR802 Semi-fixed 3.3K (B)
RDPS □□□ J	R801, R802, R804-R850, R852-R860
RD½PF 561J	R803

OTHER

Part No.	Symbol & Description
RKP-046	Connector 3P

SEMICONDUCTORS

Part No.	Symbol & Description
TA7318P	IC801
μPC324C	IC802
μPD4050C	IC803
PD4004	IC804
2SC1740LN	Q801, Q802, Q804-Q807
2SA733A	Q803
1S2473	D801-D811, D813-D822

12.10 INTEGRATED AMPLIFIER ASSEMBLY (RWX-360)

Parts List

CAPACITORS

Part No.	Symbol & Description
CEA 100P 16	C1001, C1007, C1021
CEA 221P 25	C1018
CEA 101P 25	C1021
CEA 470P 16	C1006
CEA 330P 16	C1011
CEA 100P 25	C1010
CEA 4R7P 35	C1009
CEA 010P 50	C1013
CSSA R33M 25	C1014
CEA 100P 35	C1015
CEANL 100P 16	C1003
CEANL R47P 50	C1005
CQMA 683K 50	C1017
CCDSL 101K 50	C1002, C1008, C1016
CCDSL 220K 50	C1004, C1020

Note: When ordering resistors, convert resistance value into code form, then rewrite the part no. as before.

RESISTORS

Part No.	Symbol & Description
RD½PS □□□ J	R1001-R1015, R1017, R1018

SEMICONDUCTOR AND OTHER

Part No.	Symbol & Description
PA-4001	IC1001
RKF-015	Connector

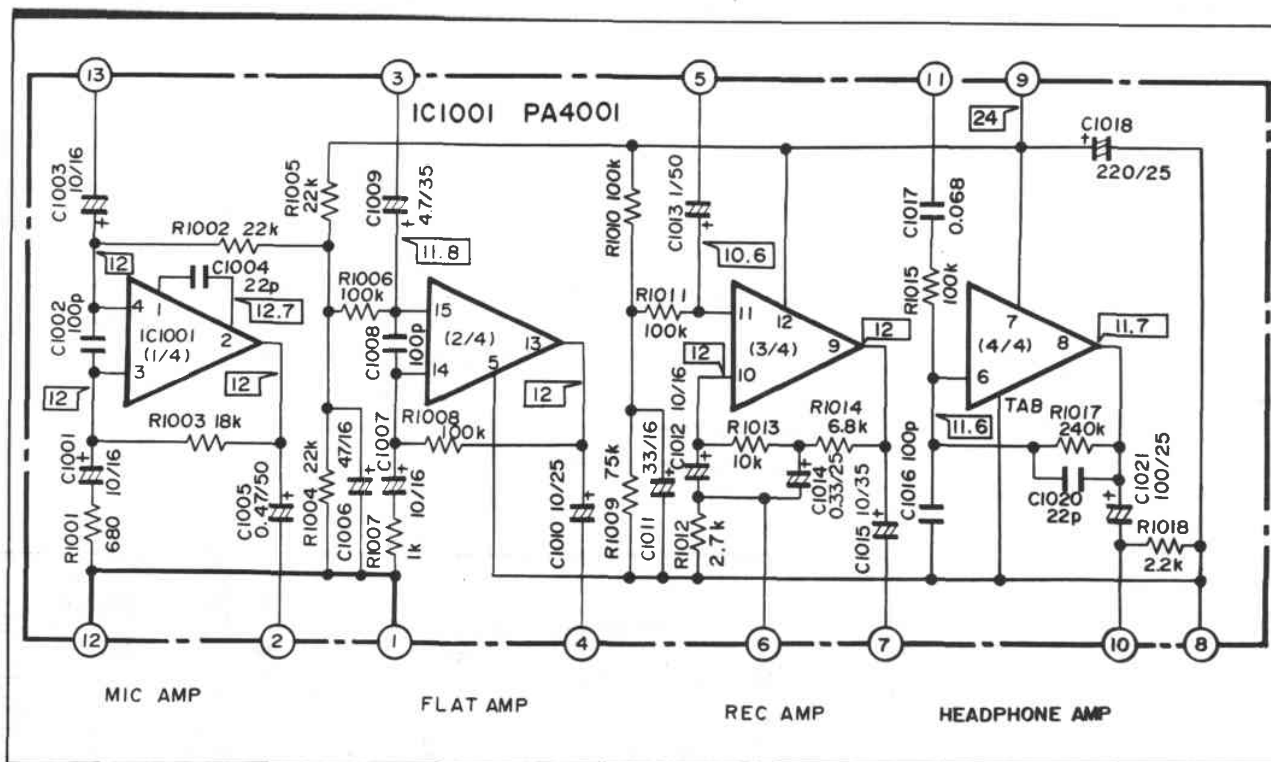

Mother Ass'y, No.2 (Lch)
 Mother Ass'y, No.5 (Rch)
 Mother Ass'y No.1 (Lch)
 Mother Ass'y No.4 (Rch)

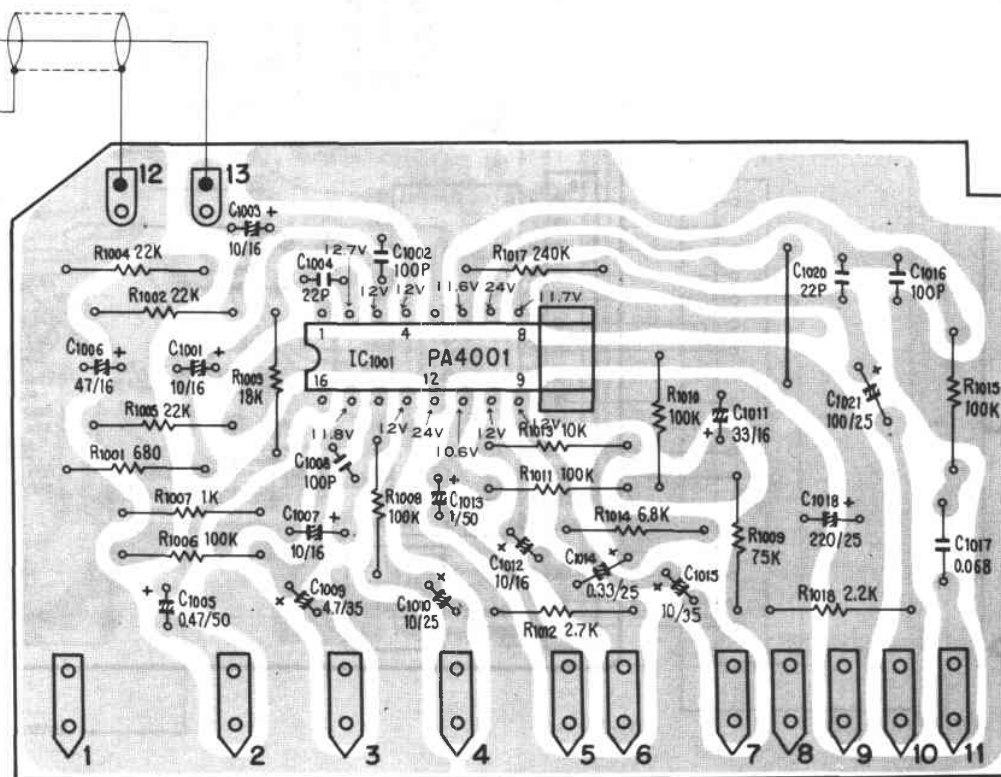

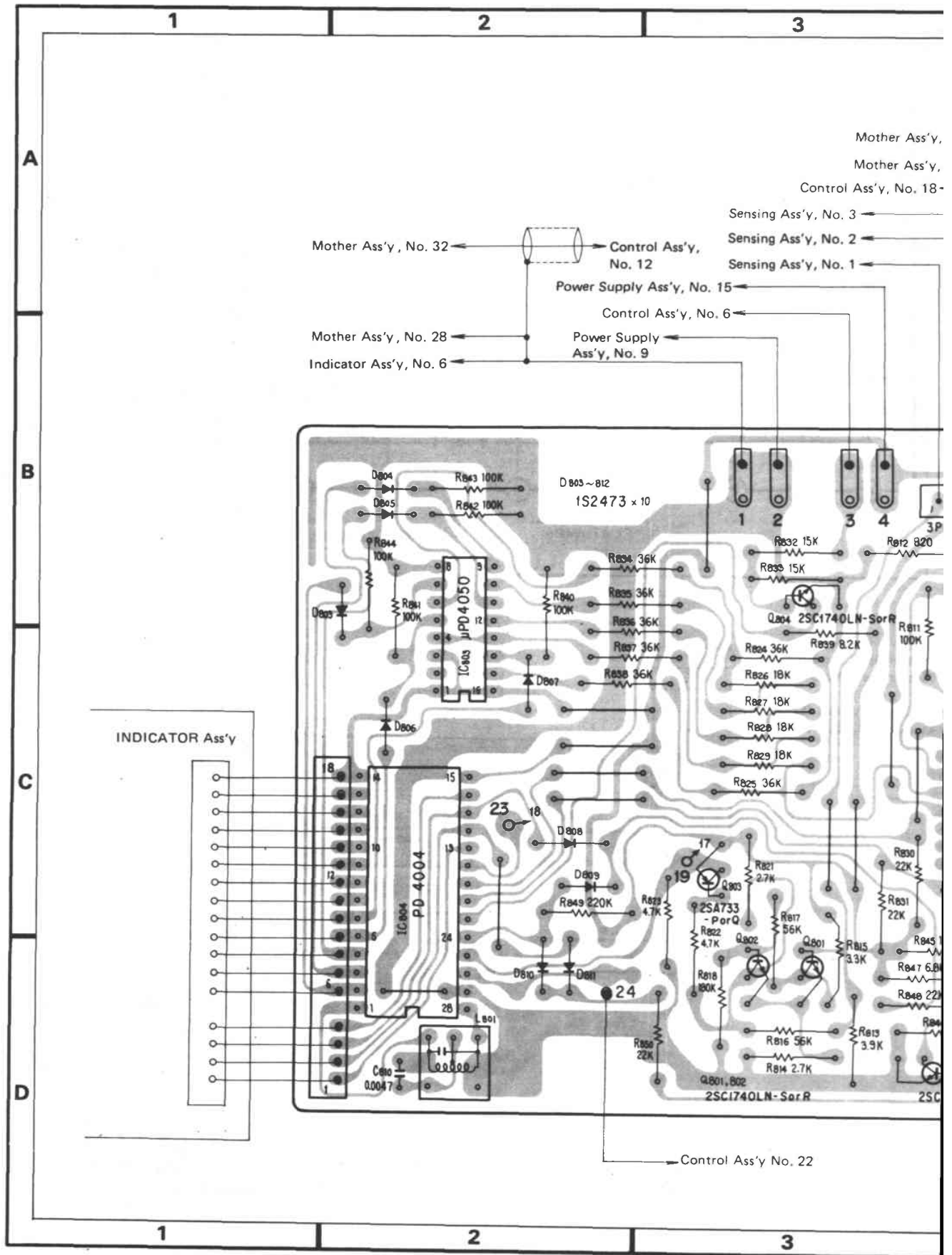

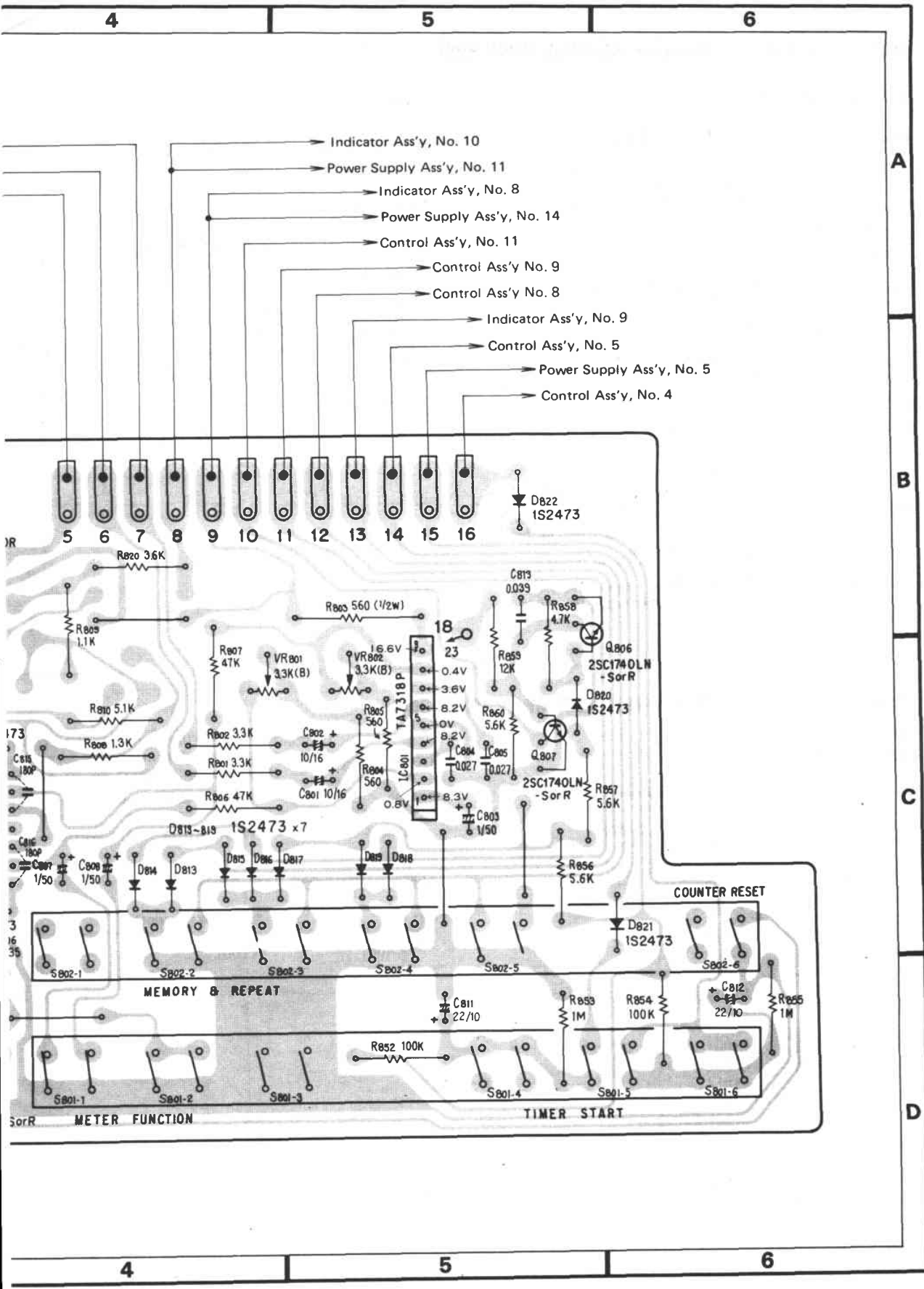

Power Supply Assembly (RWR-067)

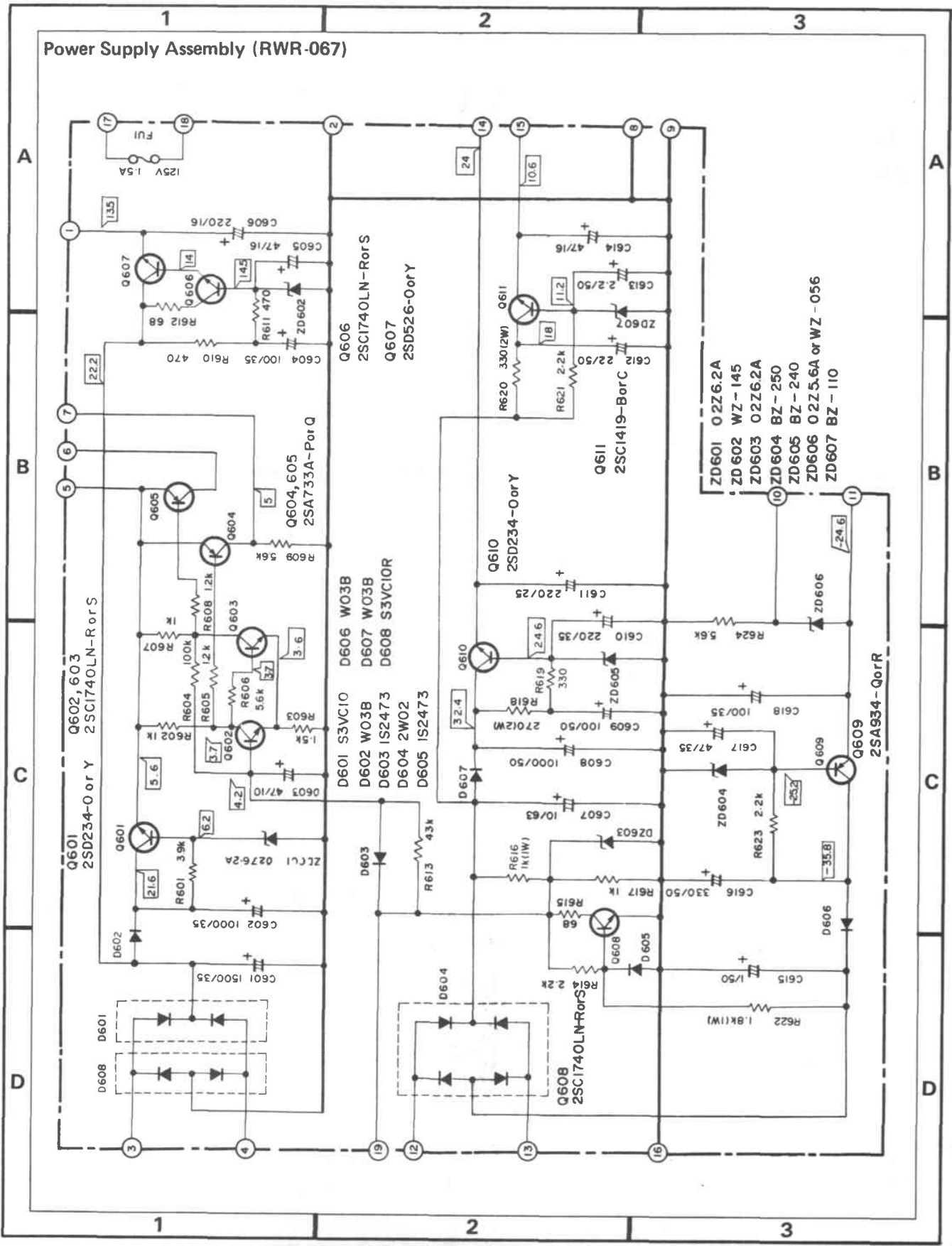

- ZD601 02Z6.2A
- ZD602 WZ-145
- ZD603 02Z6.2A
- ZD604 BZ-250
- ZD605 BZ-240
- ZD606 02Z5.6A or WZ-056
- ZD607 BZ-110

12.11 POWER SUPPLY ASSEMBLY (RWR-067)

Parts List

FUSE

Part No.	Symbol & Description
REK-063	FU1 Fuse 1.5A

CAPACITORS

Part No.	Symbol & Description
CEA 152P 35	C 601
CEA 102P 35	C 602
CEA 470P 10	C 603
CEA 101P 35	C604, C618
CEA 470P 16	C605, C 614
CEA 221P 16	C 606
CEA 100P 63	C 607
CEA 102P 50	C 608
CEA 101P 50	C 609
CEA 221P 35	C 610
CEA 221P 25	C 611
CEA 220P 50	C 612
CEA 2R2P 50	C 613
CEA 010P 50	C 615
CEA 331P 50	C 616
CEA 470P 35	C 617

Note: When ordering resistors, convert the resistance value into code form, and then, rewrite the part no. as before.

RESISTORS

Part No.	Symbol & Description
RD $\frac{1}{2}$ PSF □□□ J	R601, R610-R612, R621, R623
RD $\frac{1}{2}$ PS □□□ J	R602-R609, R613-R615, R617, R624
RS1PF □□□ J	R616, R619, R622
RCN-039	R618 270 2W
RCN-040	R620 330 2W

SEMICONDUCTORS

Part No.	Symbol & Description
2SD234	Q601, Q610
2SC1740LN	Q602, Q603, Q606, Q608
2SA733A	Q604, Q605
2SD526	Q607
2SA934	Q609
2SC1419	Q611

Part No.	Symbol & Description
S3VC10	D601
W03B (S1B01-01)	D602, D606, D607
1S2473	D603, D605
2W02	D604
S3VC10R	D608
02Z6.2A	ZD601, ZD603
WZ-145	ZD602
BZ-250	ZD604
BZ-240	ZD605
02Z5.6A (WZ-056)	ZD606
BZ-110	ZD607

OTHERS

Part No.	Symbol & Description
RKH-005	Insulator
REE-051	Insulator

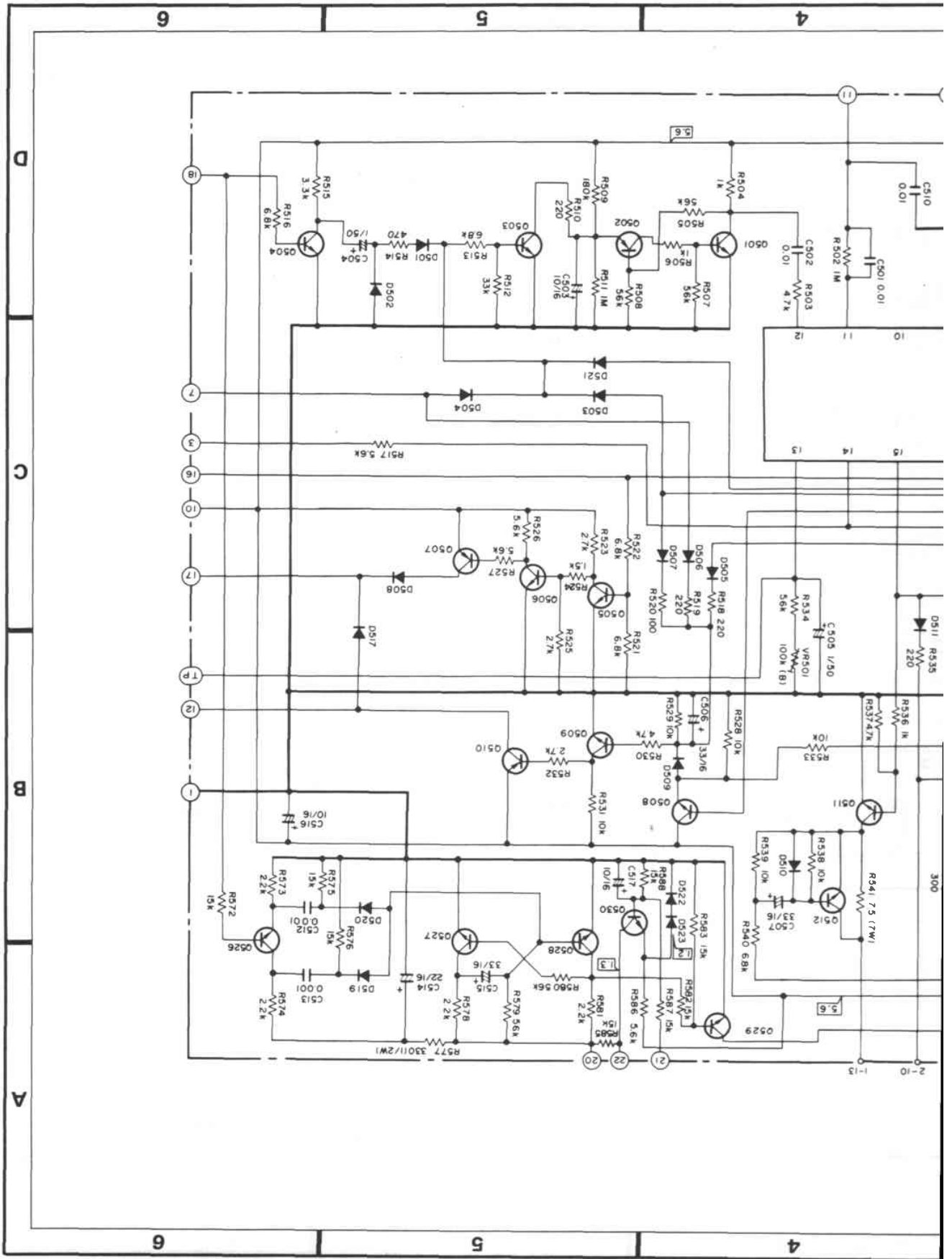

12.12 CONTROL ASSEMBLY (RWG-103)

Q502, 507, 510, 524 2SA733A - Por Q

D501 ~ 523 1S2473

Q520, 521 2SA934 - Q or R

IC 501 TC9121P

Q511 ~ 513 2SD686 or 2SD837 - Q

Q516 ~ 519, Q522 2SC2060 - Q or R

Q501, 503 ~ 506, 508, 509, 514, 515, 523, 525 ~ 530 2SC1740LN - R or S

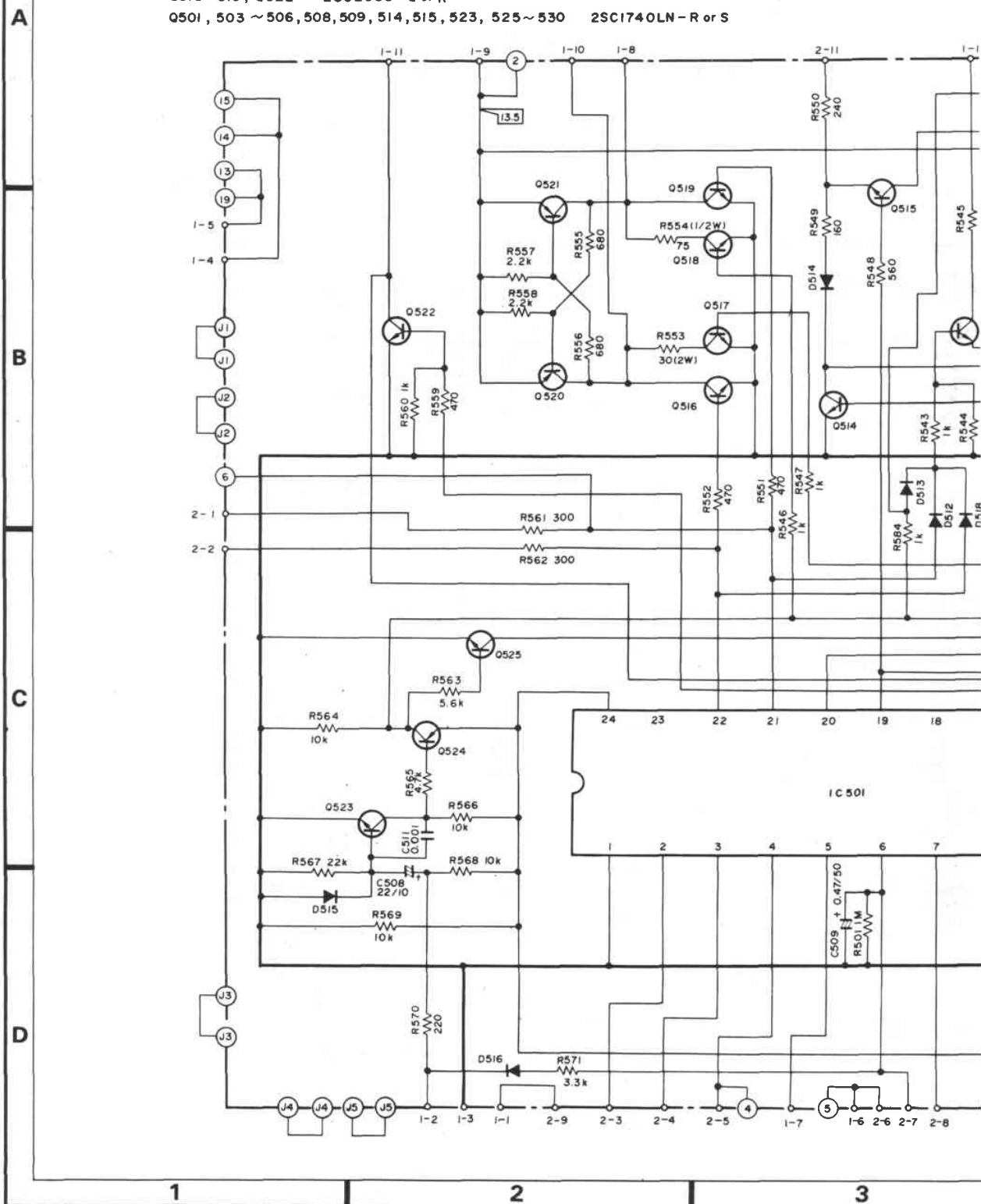

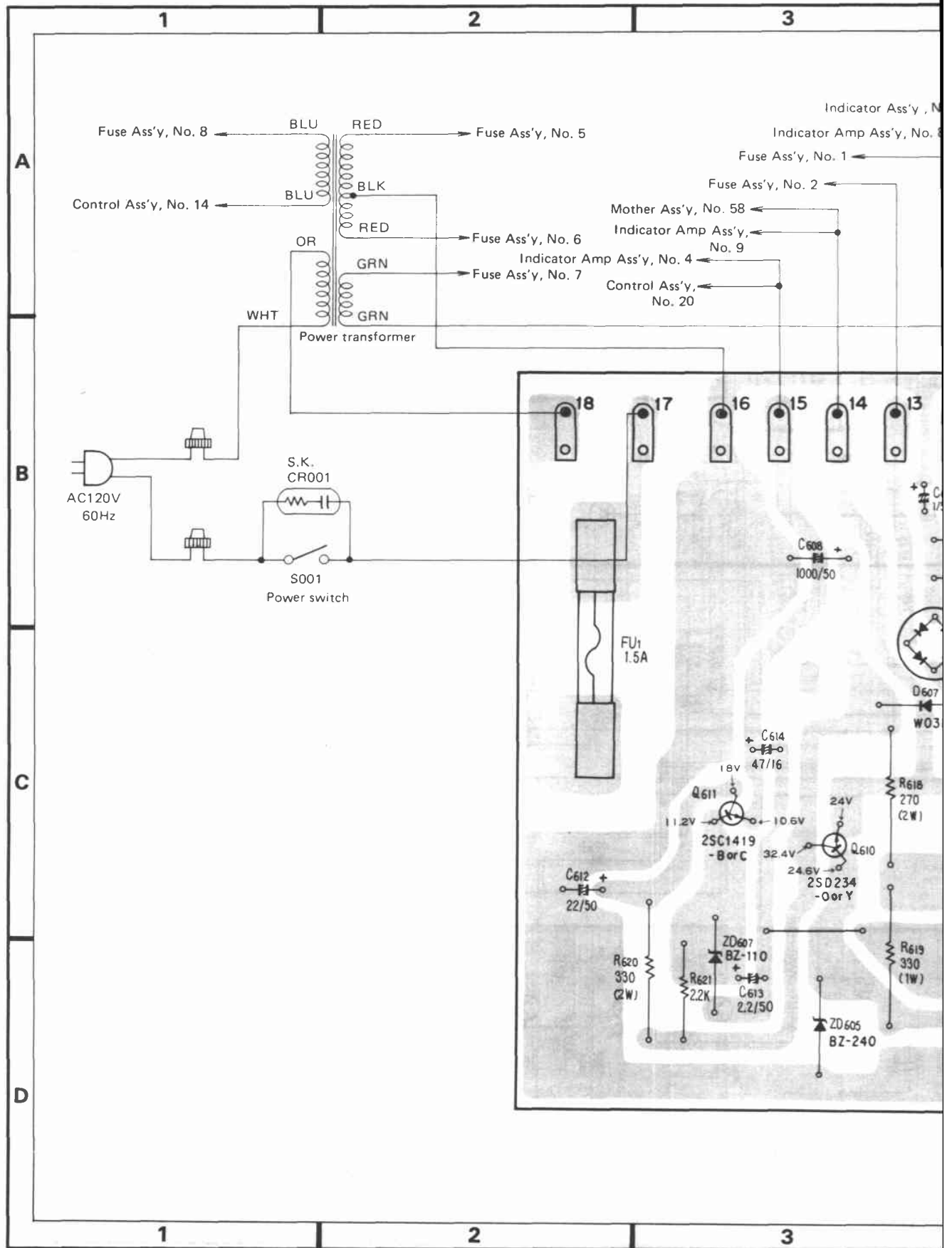

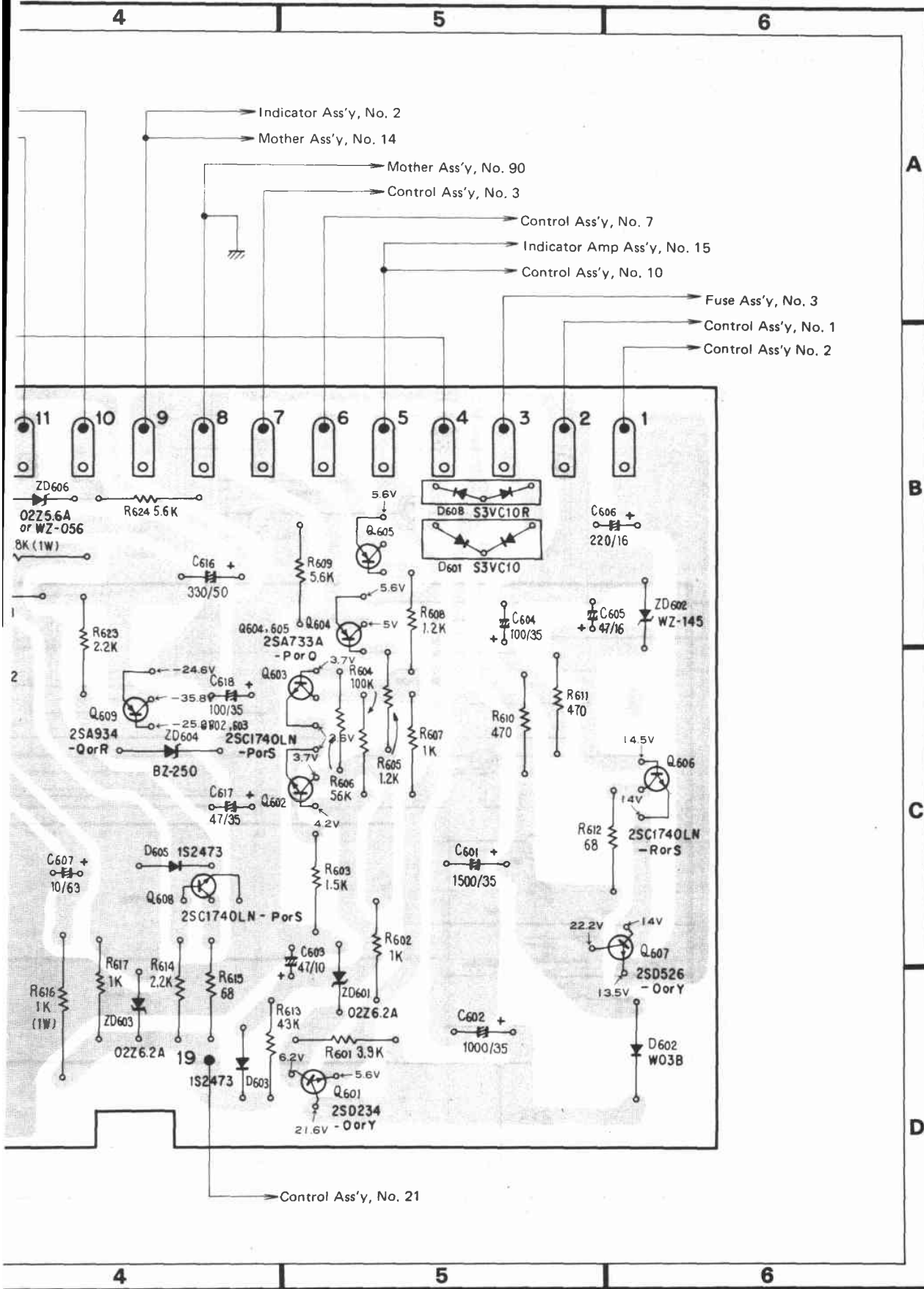

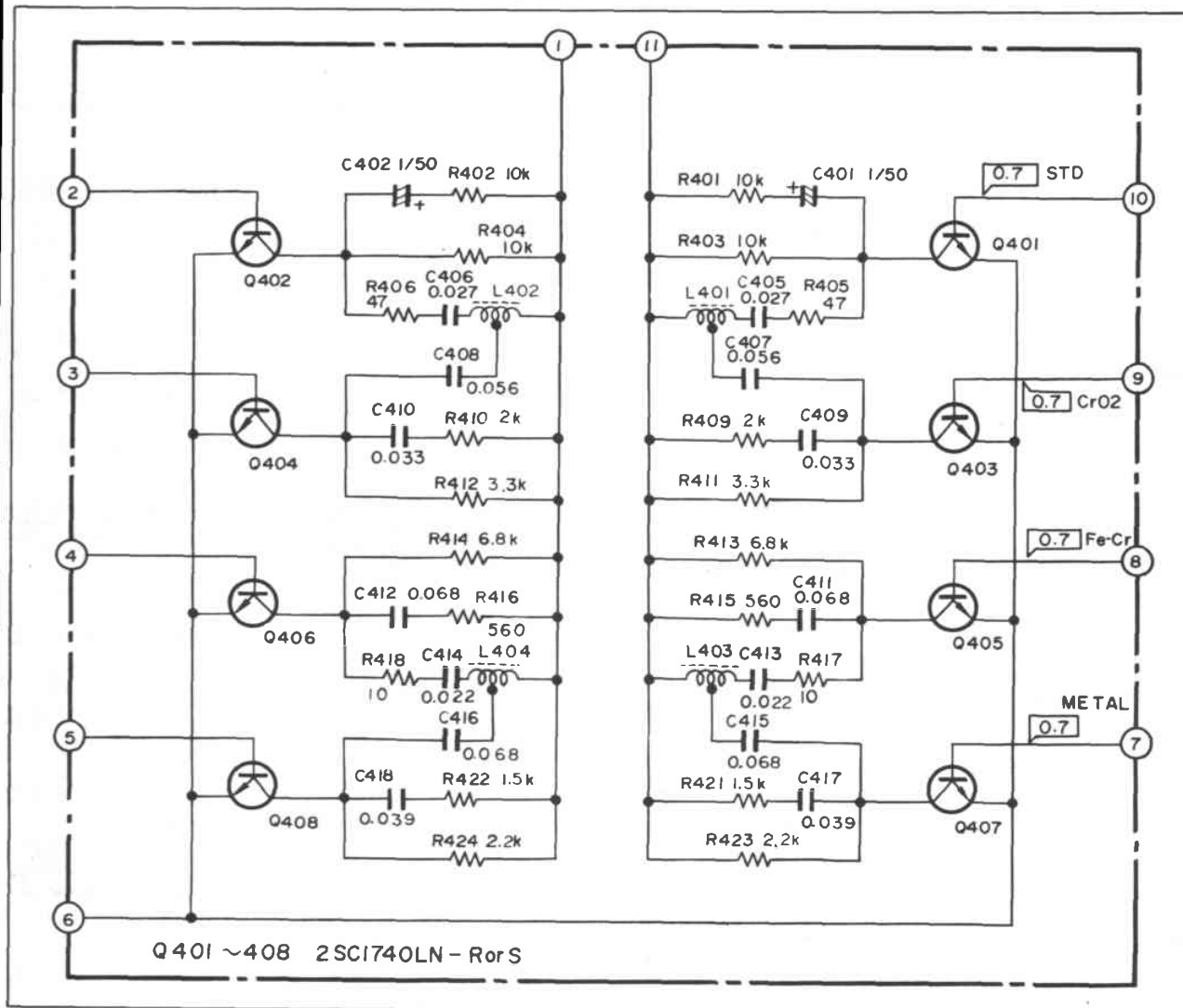

Parts List

COILS

Part No.	Symbol & Description
RTF-069	L401, L402 Peaking coil
RTF-070	L403, L404 Peaking coil

CAPACITORS

Part No.	Symbol & Description
CEA 010P 50	C401, C402
CQMA 683J 50	C411, C412, C415, C416
CQMA 563J 50	C407, C408
CQMA 393J 50	C417, C418
CQMA 333J 50	C409, C410
CQMA 273J 50	C405, C406
CQMA 223J 50	C413, C414

RESISTORS

Part No.	Symbol & Description
RD4PM 000J	R401, R402, R405, R406, R409-R418
RD4PS 103J	R421-R424
RD4VS 103J	R403
	R404

SEMICONDUCTORS

Part No.	Symbol & Description
2SC1740LN	Q401-Q408

OTHER

Part No.	Symbol & Description
RKF-019	Connector

Note: When ordering resistors, convert the resistance value into code form, and then rewrite the part no. as before.

Parts List of Control Assembly (RWG-103)

CAPACITORS

Part No.	Symbol & Description
CQMA 103K 50	C501, C502, C510
CEA 330P 16	C506, C507, C515
CEA 220P 16	C514
CEA 220P 10	C508
CEA 100P 16	C503, C516, C517
CEA 010P 50	C504, C505
CEA R47P 50	C509
CQMA 102K-50	C511-C513

Note: When ordering resistors, convert the resistance value into code form, and then rewrite the part no. as before.

RESISTORS

Part No.	Symbol & Description
C92-047	VR501 Semi-fixed 100k-(B)
RD½PS □□□ J	R501-R540, R542-R544, R546-R552, R555-R576, R578-R588

Part No.	Symbol & Description
RD½PF □□□ J	R554
RD½PS □□□ J	R577
RCN-032	R541 Wire wound 7.5 2W
RCN-031	R545 Wire wound 3.9 2W
RCN-037	R553 Wire wound 30 2W

SEMICONDUCTORS

Part No.	Symbol & Description
TC9121P	IC501
2SC1740LN	Q501, Q503-Q506, Q508, Q509, Q514, Q515, Q523, Q525-Q530
2SA733A	Q502, Q507, Q510, Q524
2SD686 (2SD837)	Q511-Q513
2SC2060	Q516-Q519, Q522
2SA934	Q520, Q521
1S2473	D501-D523

12.13 REC EQ ASSEMBLY (RWX-361)

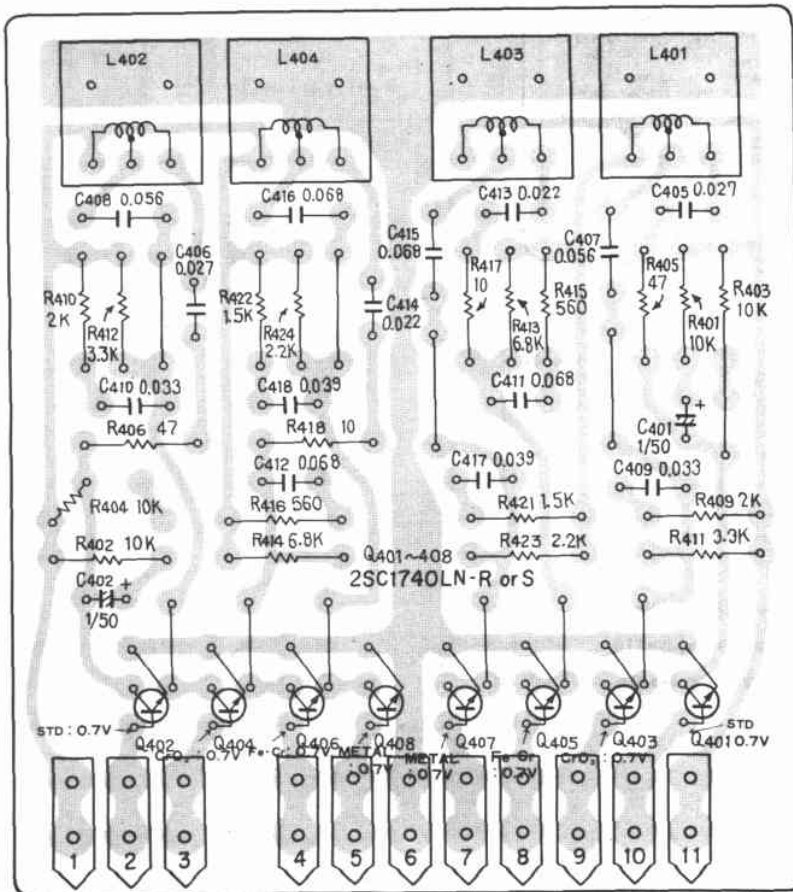

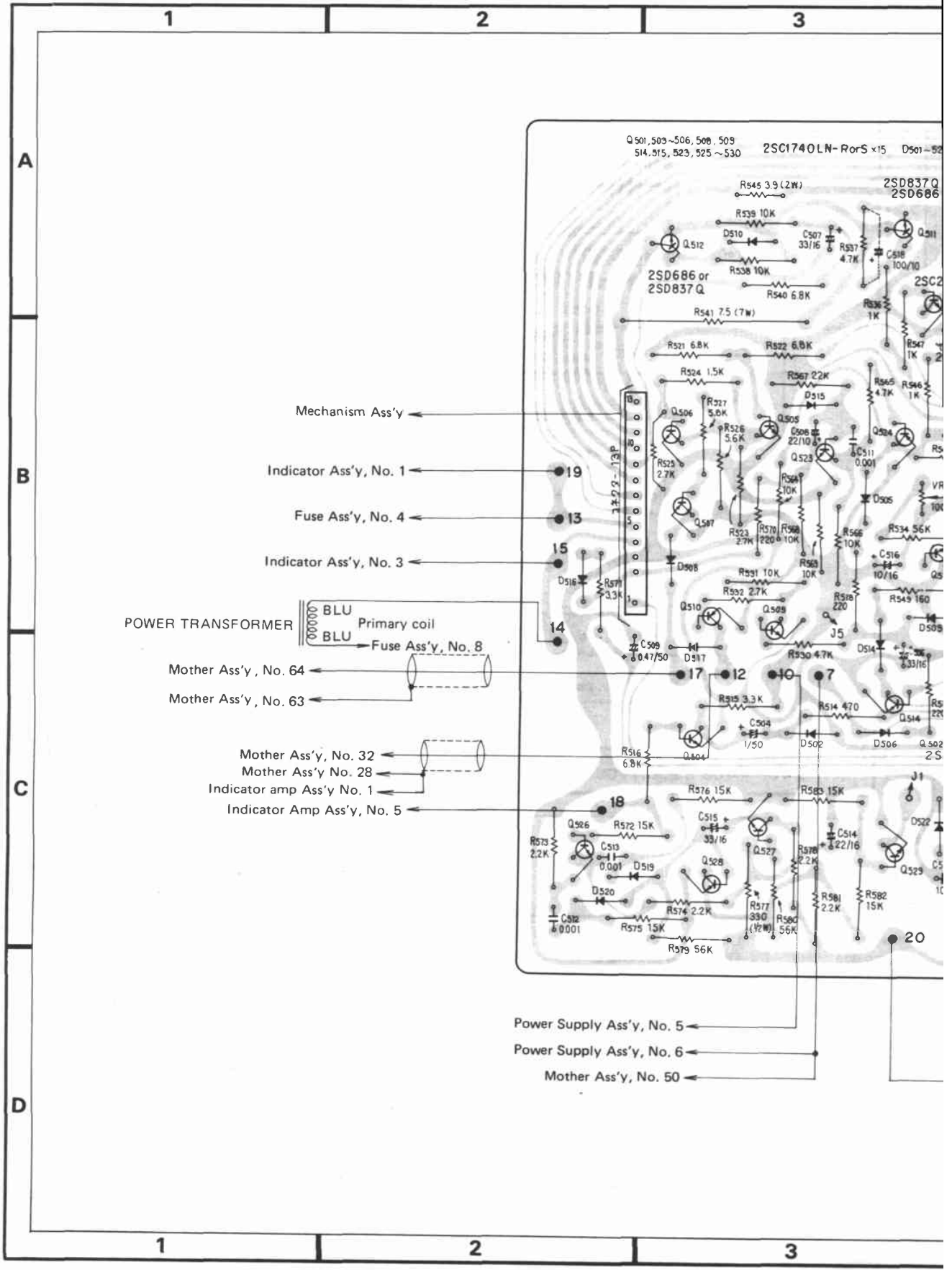

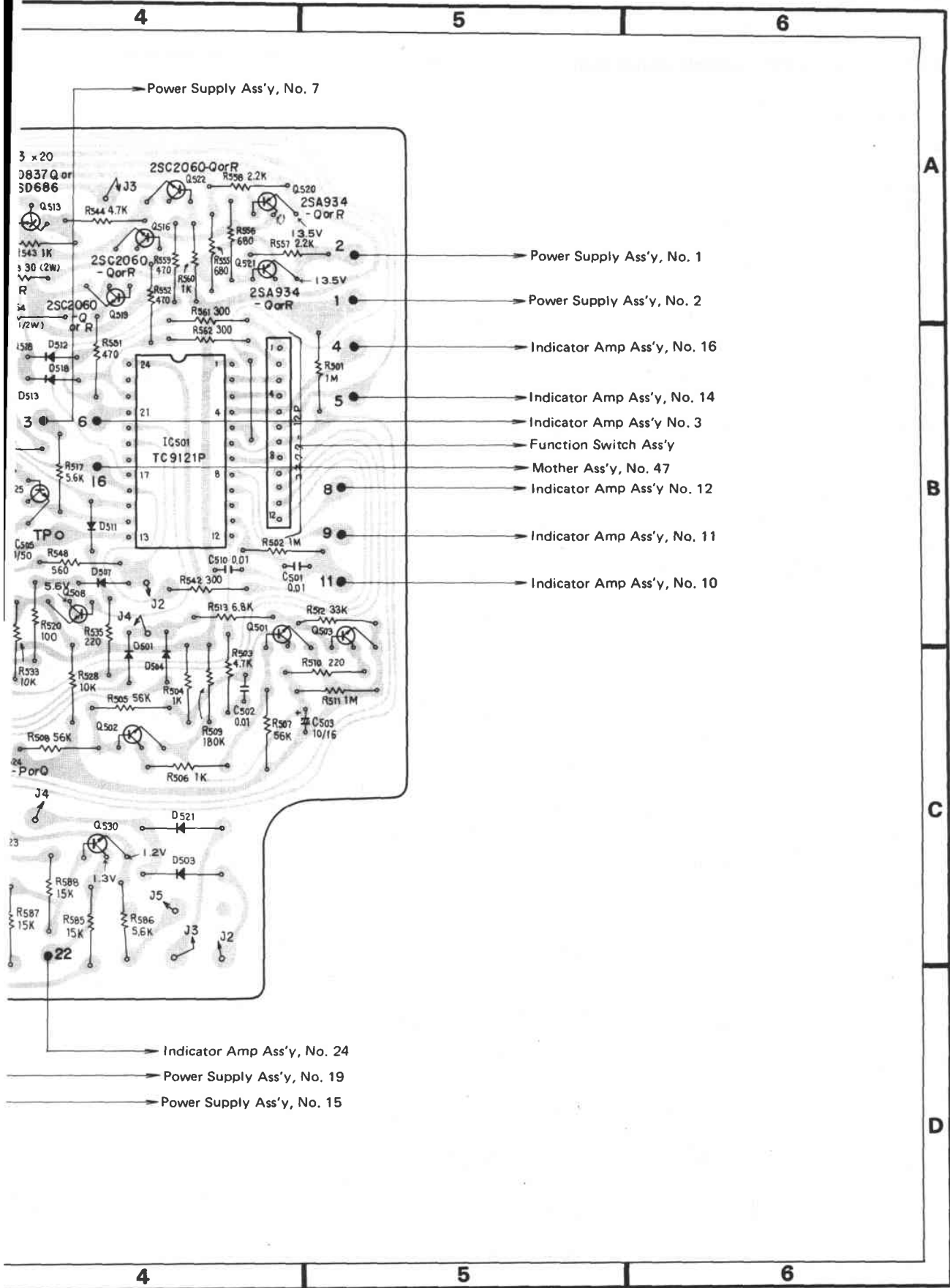

12. 14 TAPE SELECTOR ASSEMBLY

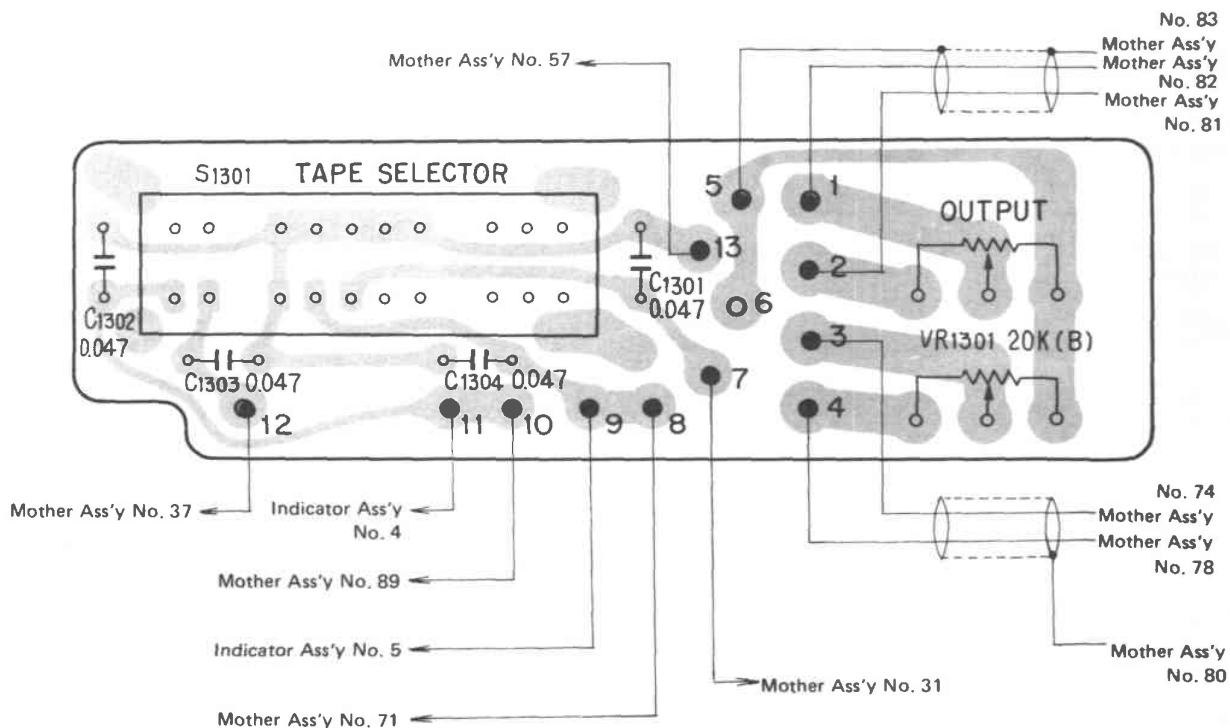
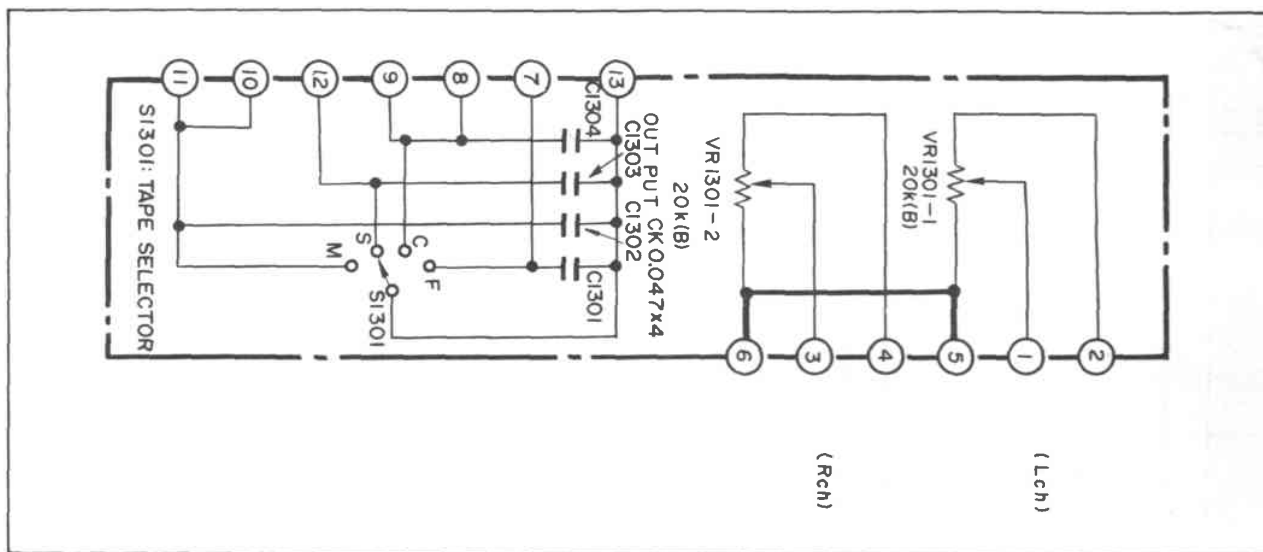

Parts List

Part No.	Symbol & Description
RSB-020	S1301 Switch (TAPE)
RCV-064	VR1301 Volume 20K (B) (OUTPUT)
CKDYF 473Z 50	C1301-C1304

12.15 FUSE ASSEMBLY

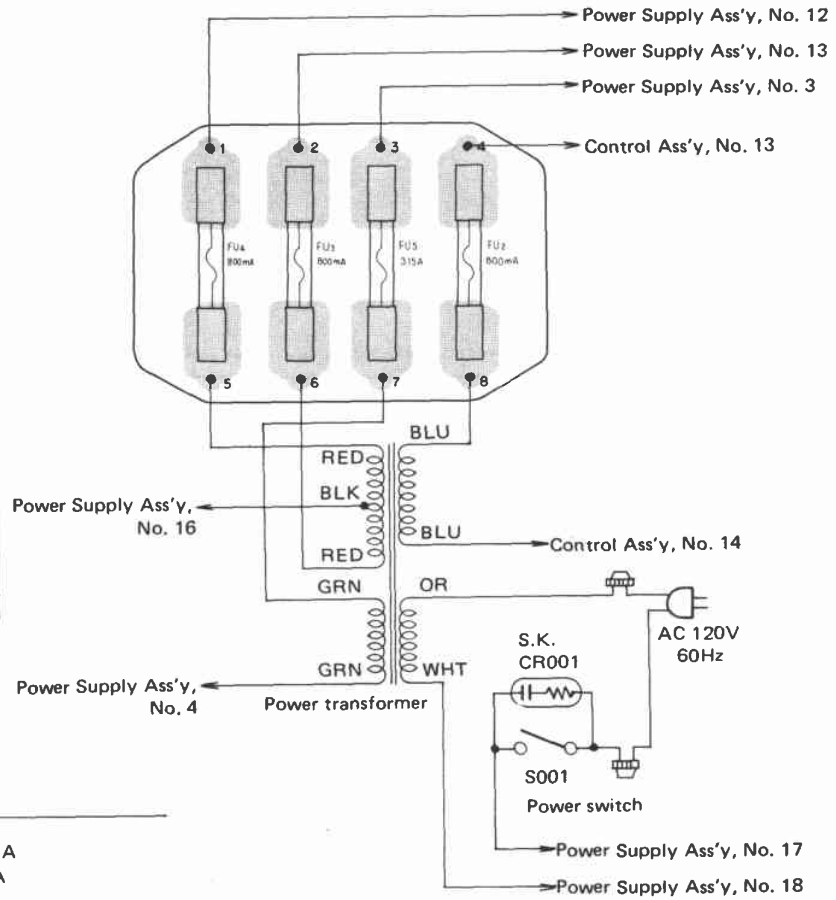
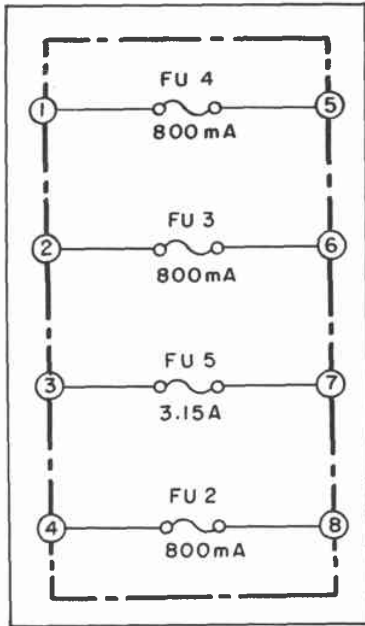

Parts List

Part No.	Symbol & Description
REK-058	FU2-FU4 Fuse 800mA
REK-044	FU5 Fuse 3.15A

13. TROUBLE SHOOTING

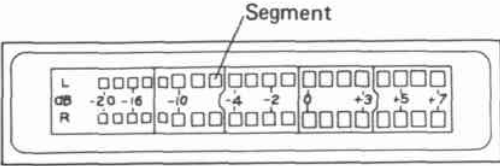
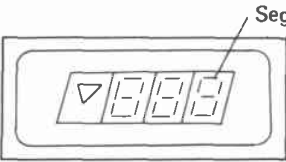
CONDITION	CAUSE AND REPAIR
<ul style="list-style-type: none"> Fluorescent indicator lamps (level meters and tape counter) do not light up, even though voltage is applied to the filament. 	<ul style="list-style-type: none"> Defective Q₇₀₁ (2SA733) in the indicator assembly.
<ul style="list-style-type: none"> Level meter segments (see Fig. 13-1) fail to light up even though the numerals and the tape counter are on.  <p style="text-align: center;">Fig. 13-1</p>	<ul style="list-style-type: none"> Load a recorded tape or test tape and check the presence of an input signal. Defective IC₈₀₁ (TA7318P) or IC₈₀₂ (μPC324) in the indicator amplifier assembly.
<ul style="list-style-type: none"> Only one, or two, columns in the tape counter light up. 	<ul style="list-style-type: none"> Defect in the parallel vinyl-covered leads connecting the indicator assembly to the indicator amplifier assembly. Defective IC₈₀₄ (PD4004) in the indicator amplifier assembly.
<ul style="list-style-type: none"> One of the segments in the tape counter digits fails to light up (see Fig. 13-2).  <p style="text-align: center;">Fig. 13-2</p>	<ul style="list-style-type: none"> Defective soldering of a component in the indicator assembly (if the level meter is operating normally). Defective IC₈₀₄ (PD4004) in the indicator amplifier assembly (if the level meter is not operating properly).
<ul style="list-style-type: none"> Only one of the level meter segments lights up, or else the segments light up and turn off again rather sporadically. 	<ul style="list-style-type: none"> Defective IC₈₀₄ (PD4004).
<ul style="list-style-type: none"> The level meter numerals do not light up. 	<ul style="list-style-type: none"> Defective soldering of component(s) in the indicator assembly. A break in the parallel vinyl-covered leads connecting the indicator assembly to the indicator amplifier assembly.
<ul style="list-style-type: none"> Level meter and tape counter lamps are rather dull. 	<ul style="list-style-type: none"> Defective Q₇₀₁ (2SA733) in the indicator assembly.
<ul style="list-style-type: none"> Tape counter does not return to 000 when the COUNTER RESET is pressed. 	<ul style="list-style-type: none"> Defective IC₈₀₄ (PD4004). Defective COUNTER RESET push-button.