

HiFi ENGINE®

For more Hi-Fi manuals and set-up information
please visit www.hifiengine.com

CT-F750

HE, HB
D, D/G

OPERATING INSTRUCTIONS



Before turning on the power, please confirm the setting of the line VOLTAGE SELECTOR plug on the rear panel. If it is not set properly, change the setting of it according to the IMPORTANT—LINE VOLTAGE on page 16.

OPERATING THE CT-F750

The specifications of this model differ according to the shipment destination.

- For U.K. ('HB' stamped on packing case): Power line voltage is 240 volts. A 2-point (220V/240V) voltage selector switch is provided on the rear panel:
- For mainland Europe ('HE' stamped on packing case): Power line voltage is 220 volts. A 2-point (220V/240V) voltage selector switch is provided on the rear panel.
- For destinations excluding above ('D', 'D/G' stamped on packing case): A 3-point (120V/220V/240V) voltage selector switch is provided on the rear panel.

For the sake of convenience, the illustrations and explanations are based on the CT-F750/HE.

CONTENTS

Operating the CT-F750	1
Front Panel Facilities	2
Connections	4
Installation Precautions	4
Basic Operations	5
Auto Reverse and Auto Repeat Functions	6
Operating Procedure	8
Microphone Recording	10
Operations with the Timer	11
Maintenance	12
Cassette Tapes	13
The Dolby NR* System	14
Specifications	15
Important—Line Voltage	16
Troubleshooting	Insertion
Schematic Diagram	Insertion
Table of Leading Brands of Tapes	Insertion

- When hooked up to your stereo components (amplifier, tuner, turntable, etc.), you can record and play back FM or AM broadcasts, records and other program sources in stereo on this deck. In addition, you can make your own stereo recordings using an electret or dynamic microphone.
- With the cassette tape loaded in the cassette holder, the tape can easily be played back or recorded from the forward direction to the reverse direction by operating the DIRECTION selector. There is also an automatic mode where the REVERSE MODE selector is used for recording continuously on both sides of the tape or for repeat playback.
- An electronic fluorescent display tube is used for the level meter. It is extremely accurate and it copes with even sudden fluctuations in the signal level. There is a correlation between the signal strength and the length of the bar. The signals are displayed for both the left and right channels, and a switch can be used to meter selector switch the display between average and peak indication.
- Another handy feature is the REC MUTE switch which stops clicking noise from being recorded on the tape when the stylus descends onto the record during a recording of a disc program or when recording an FM broadcast and cutting out the commercials.
- The deck is provided with a headphones (PHONES) jack, and this allows you to monitor the recording or tape play with stereo headphones.
- The tape selector buttons permit full justice to be given to the characteristics of metal tapes, chrome tapes, ferrichrome tapes and standard tapes. They can also be used for recording and playback with the bare minimum of distortion.
- The Dolby noise reduction system* serves to cut out a great deal of that irritating tape hiss in the high frequency range without sacrificing the sound quality of the program source (it yields a 10dB improvement in the high frequency sound range). This system expands the dynamic range and makes it possible to record and play back sources with a high signal-to-noise ratio.
- The deck comes with an unattended recording function which can be used along with the timer for unattended recording and wake-up to the sound of a tape being played back instead of the usual alarm clock.

*Manufactured under license from Dolby Laboratories.

*Dolby and  are trademarks of Dolby Laboratories.

FRONT PANEL FACILITIES

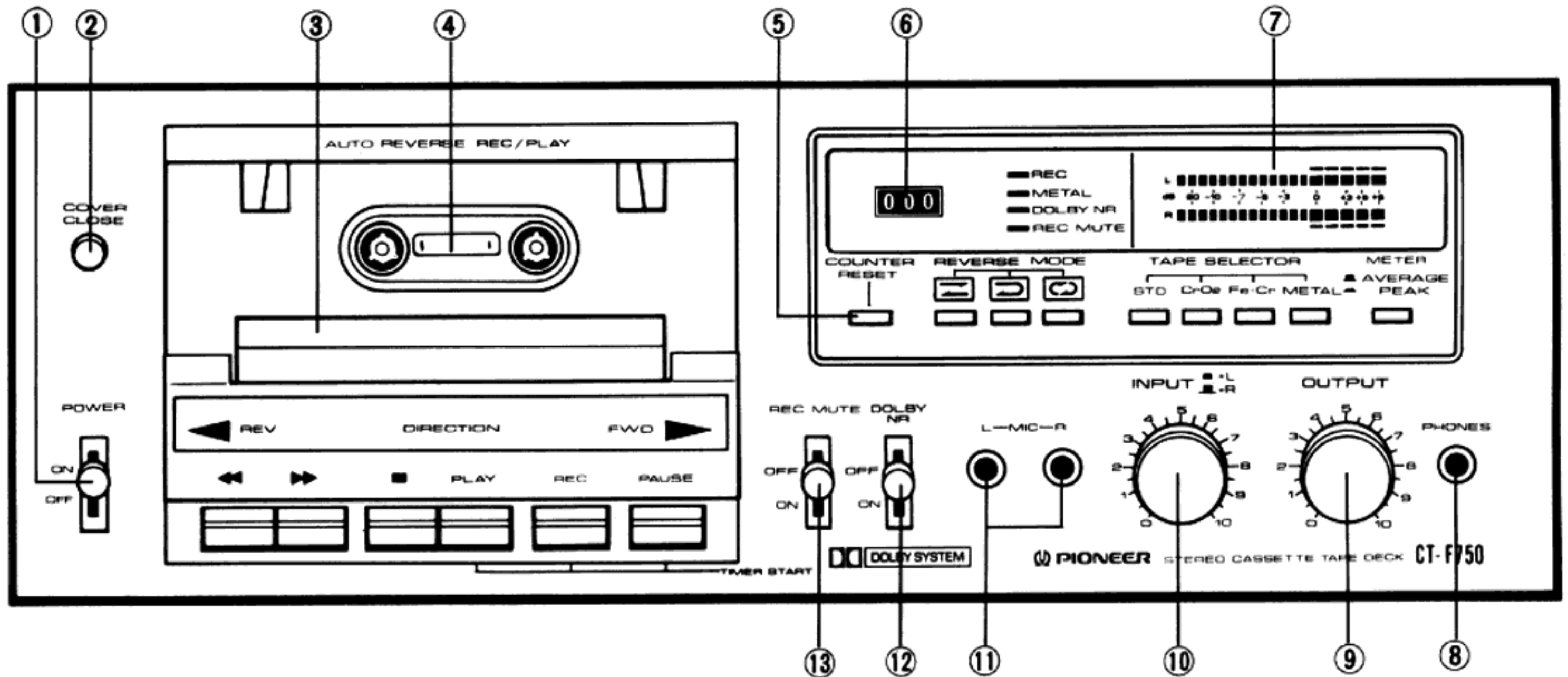

① POWER SWITCH

Power is supplied to the deck when this switch is set to ON, and the level meter lights up.

② COVER CLOSE BUTTON

Depress this button when you want to close the dust cover.

③ DUST COVER

When you are not using the deck, always keep this cover in place to prevent dust and dirt from adhering to the head section and rotating parts.

④ REMAINING TAPE MARKER

If this marker is visible, it means that there is enough tape remaining for several minutes of recording or playback.

⑤ TAPE COUNTER RESET BUTTON

Depress this button to reset the tape counter display to "000."

⑥ TAPE COUNTER

This indicates how far the tape has traveled. When the tape travels in a forward direction, the number on the counter increases but it decreases when the tape travels in the reverse direction.

⑦ LEVEL METERS

These indicate the input level during recording and the output level during playback.

By operating the METER selector switch, it can be made to function as a peak meter, or as an average meter.

⑧ HEADPHONE JACK

This is the output jack for stereo headphones. Plug your headphones into this jack when you want to monitor the quality of a recording or when you want to listen to a tape privately.

NOTES:

- Use low-impedance headphones. If you use a high-impedance model, you will not be able to obtain sufficient volume.
- You will damage the microphone if you plug it into the HEADPHONE jack by mistake.

⑨ OUTPUT (PLAYBACK LEVEL) CONTROL

Use this control to adjust the output signal level during playback. Turning the control to the right increases the level.

When playing back a reference tape (160 nwb/m), a reference playback level (0dB) is obtained with this control set to the "6" click stop position.

⑩ INPUT (RECORDING LEVEL) CONTROLS

Use these to adjust the level of the input signals from the MIC jacks or rear panel INPUT jacks.

Turning these controls to the right increases the level. How to setting the recording level is detailed on page 9.

The controls are coupled to the left and right channels, but you can also use them to adjust the right channel (rear) and the left channel (front) independently.

⑪ MIC JACKS

These are the input jacks for microphone recording. Plug the left channel microphone into the L jack and the right channel microphone into the R jack.

⑫ DOLBY NR SWITCH

Set this switch to ON for recording with the built-in Dolby noise reduction system and for the playback of tapes which have been recorded using the Dolby NR system.

⑬ REC MUTE SWITCH

Depress this switch to create unrecorded sound blanks on the tape during recording. The REC MUTE indicator comes on while the switch is depressed and the tape continues to travel but no signals are recorded. Also, the level meter indicates the input signal level which can be monitored with the headphones or speakers. For details, refer to "Using the REC MUTE switch" on page 10.

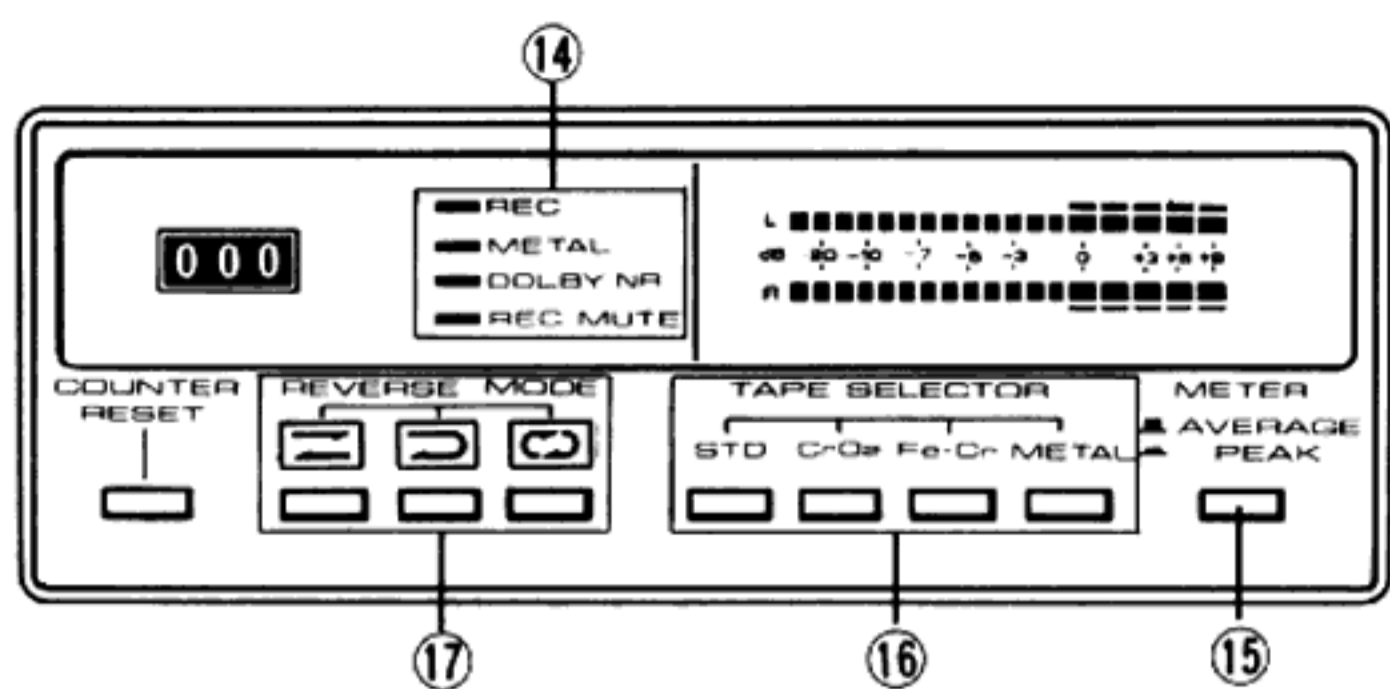

14 INDICATORS

REC INDICATOR:

This light comes on when the PLAY and REC levers are depressed together to indicate that the cassette deck is now set to the recording mode.

METAL TAPE INDICATOR:

This light comes on when the TAPE selector is set to METAL.

DOLBY NR INDICATOR:

This light comes on when the DOLBY NR switch is set to ON to indicate that the cassette deck is now set up for recording or playback using the Dolby NR system.

REC MUTE INDICATOR:

This indicator lights up when the REC MUTE lever is depressed for recording (also when the deck is set to the recording standby).

15 METER SELECTOR SWITCH

PEAK: When this switch is depressed to PEAK, the meter functions as a peak meter.

AVERAGE: When the switch is released to AVERAGE, the meter functions as an average meter.

For further details, refer to "LEVEL METER" on page 8.

16 TAPE SELECTOR

This selector allows the bias and equalizer characteristics to be selected during recording and the equalizer characteristics during playback in line with the type of tape you are using. For details, refer to "Setting the tape selectors" on page 9.

STD: For using ordinary or LH tapes

CrO₂: For using chrome tapes

Fe-Cr: For using ferrichrome tapes

METAL: For using metal tapes

17 REVERSE MODE SELECTORS

These selectors can be operated for automatic two-way recording or playback or for continuous repeat playback.

: Depress this selector for one-way recording or playback with the tape in the forward or reverse direction.

: Depress this selector for two-way recording or playback.

: Depress this selector for continuous repeat playback.

For details, refer to "AUTO REVERSE, AUTO REPEAT" on page 6.

NOTE:

Do not depress more than one of these selector buttons at a time.

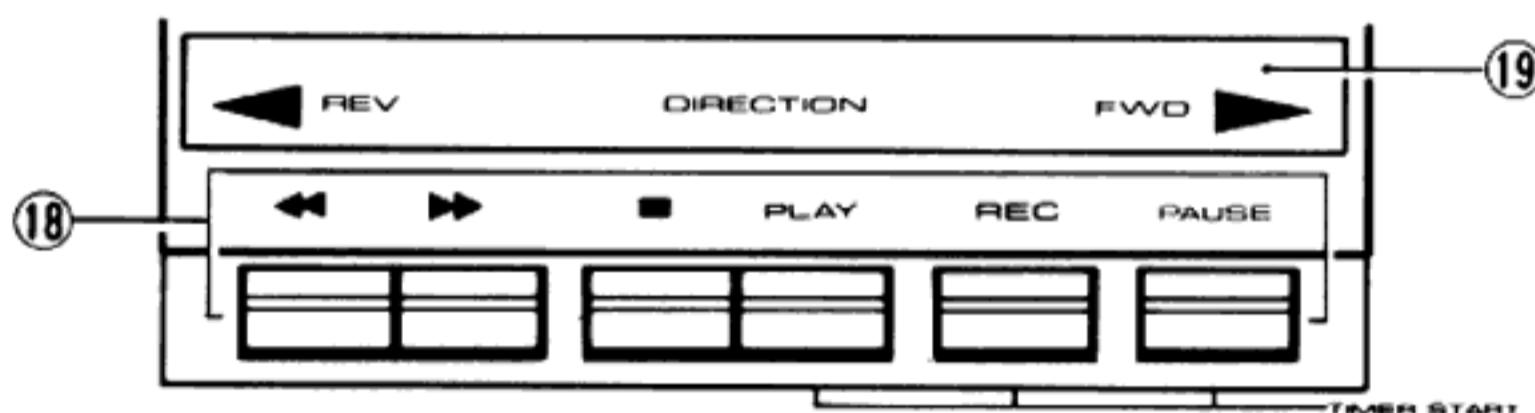

18 OPERATING LEVERS

. Depress this lever to rewind the tape. (The tape will travel at high speed from right to left.)
(Rewind)

. Depress this lever to send the tape forward at top speed. (The tape will travel from left to right.)
(Fast forward)

. Depress this lever to stop the tape run and to release the operating levers.
(Stop)

PLAY Depress this lever when playing back a tape. Use the DIRECTION SELECTORS to choose the tape run direction. Use the REVERSE MODE SELECTOR for return and repeat playback.

REC Depress this lever together with the PLAY lever for recording.

This lever will not work when a cassette is not loaded or when the erasure prevention tabs of a loaded cassette have been broken off.

PAUSE Depress this lever to stop the tape temporarily during recording or playback. Depress it again to allow the tape to continue to travel as before.

NOTES:

1. Apart from the PLAY, REC levers and pause operation, do not depress any of the levers simultaneously.
2. The operating levers will not return to their original positions even when the power is switched OFF.

19 DIRECTION SELECTOR

This selector is used to select the tape travel direction during playback or recording. When depressed (and it may be depressed anywhere), one of the two lamps comes on to indicate the tape travel direction, and the tape travel is reversed.

FWD : The tape is traveling from left to right (forward direction).

REV : The tape is traveling from right to left (reverse direction).

With unattended recording and wake-up playback, the tape will start to travel in the FWD direction automatically no matter which mode is set before auto start.

NOTES:

- Even when the deck is set to the playback, recording or pause mode, the tape direction will be reversed when this selector is depressed.
- This selector will not work when the deck is set to the rewind and fast forward modes.
- When the POWER switch is set to ON, the forward indicator (FWD) lights up no matter what the mode of the reverse mode selector, and the tape direction is set to forward. When the PLAY lever is depressed, the tape travels from left to right.

CONNECTIONS

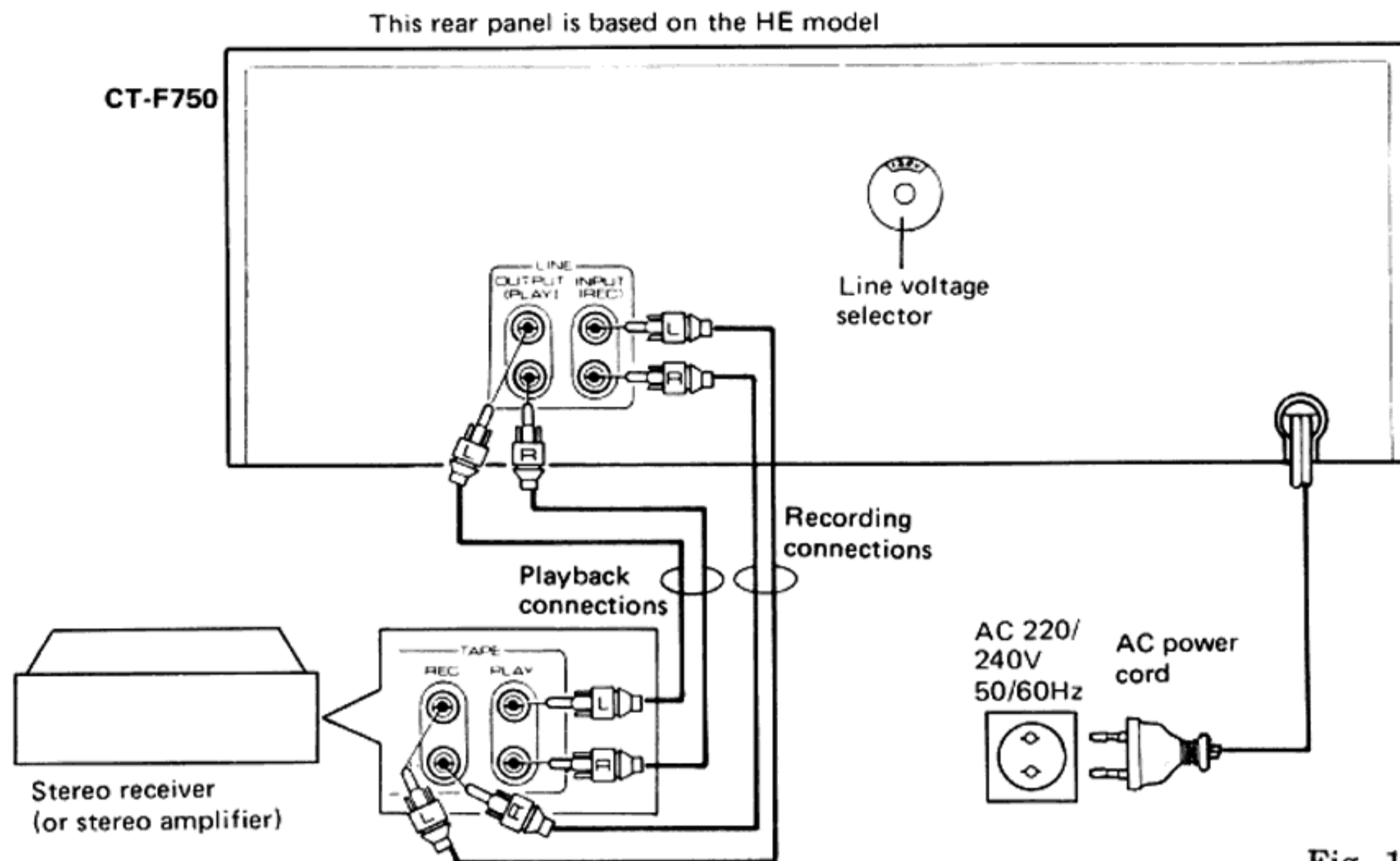

Fig. 1

Before making a connection, turn off the stereo amplifier's power switch in order to prevent any adverse effect upon other audio components.

Connect the tape deck's terminals (OUTPUT—INPUT) to the tape terminals on the receiver (or stereo amplifier) with the accessory cords. The top terminal is for the left channel and the bottom for the right channel.

Connections for playback: connect the TAPE PLAY input terminals on the receiver to the tape deck's OUTPUT (PLAY) terminals.

Connections for recording: connect the receiver's TAPE REC output terminals to the tape deck's INPUT (REC) terminals.

HANDLING THE POWER CORD

- Do not handle the power cord with wet hands. This is extremely dangerous since you may get an electric shock.
- Always take hold of the plug to unplug it from the power outlet -- do not unplug it by pulling on the cord. The cord may be damaged if you keep pulling on it.

INSTALLATION PRECAUTIONS

To ensure the best sound quality and trouble-free operation, avoid setting up the tape deck in any of the locations described below.

Location liable to downgrade performance and result in breakdowns	Resulting trouble
1. Locations exposed to direct sunlight, or near heaters or other heat sources.	1. External heat causes the performance of the electronic parts to deteriorate, and operation becomes unstable.
2. Locations with poor ventilation, or with high humidity or moisture contents, or dusty locations.	2. Cause of faulty contact in input/output terminals, and rust. High humidity and high moisture content cause deterioration in insulation. There is also the danger of current leakage and heat generation in the circuit parts. Dust or grease in the rotating parts causes the parts to deteriorate.
3. Locations susceptible to vibration.	3. These locations affect the precision parts adversely.
4. Locations where there are thinners, benzine and other types of volatile liquids, insect sprays or any kind of inflammable objects at hand.	4. These help to corrode the front panel. In particular, the heads are precision-finished to micron dimensions. Chemicals may reduce their performance, so exercise all due care.

BASIC OPERATIONS

TAPE INSERTION

- Place your forefinger on the edge of the dust cover and pull towards you.
- Hold the cassette tape with the exposed tape face down. Turn side A towards you unless it is not possible to use this side any longer.
- Align the cassette with the left and right tape guides, push down on it lightly and load it into the head section.
- To remove the cassette, take hold of the bottom part and pull the cassette towards you.
- When you do not intend to use the cassette deck, depress the COVER CLOSE button and close the cover.

NOTE:
Be sure not to take out cassette tape during tape running.

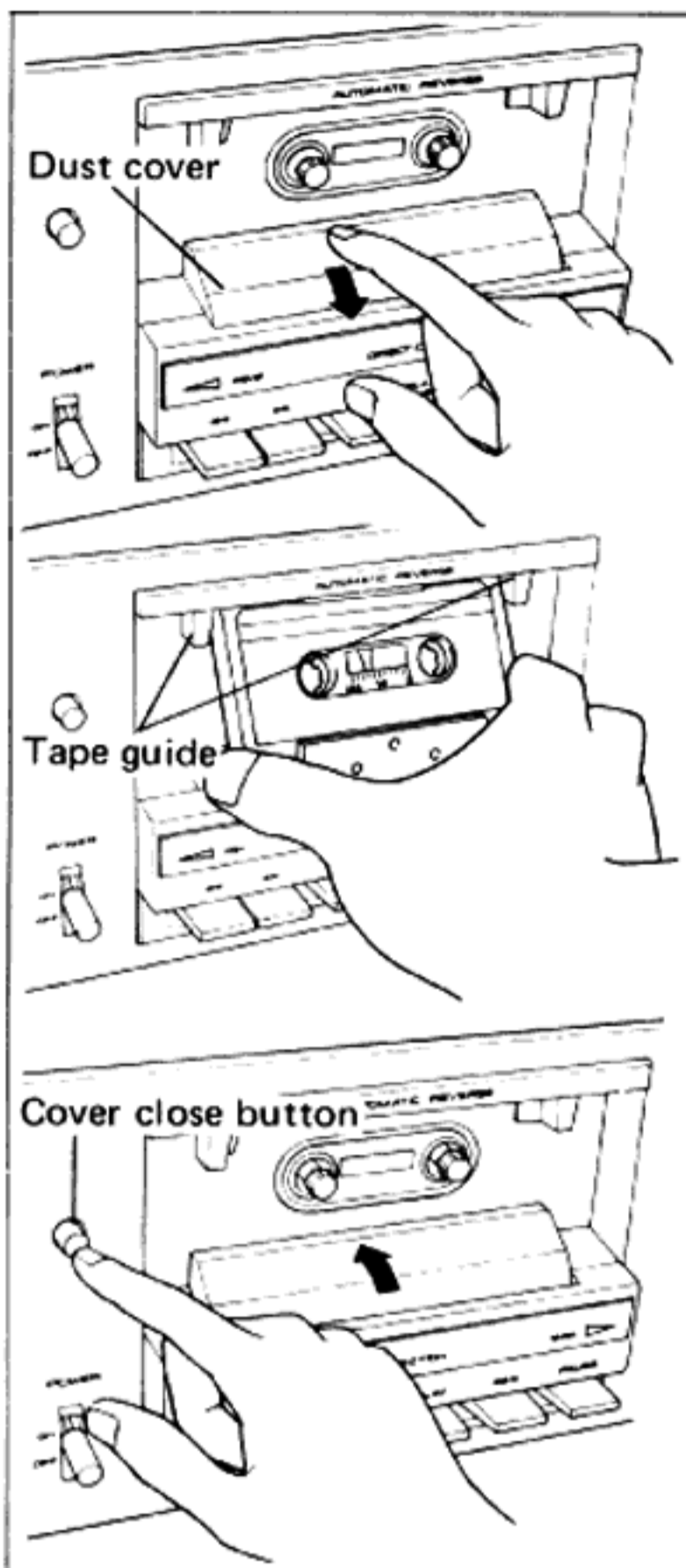

TAPE RUN

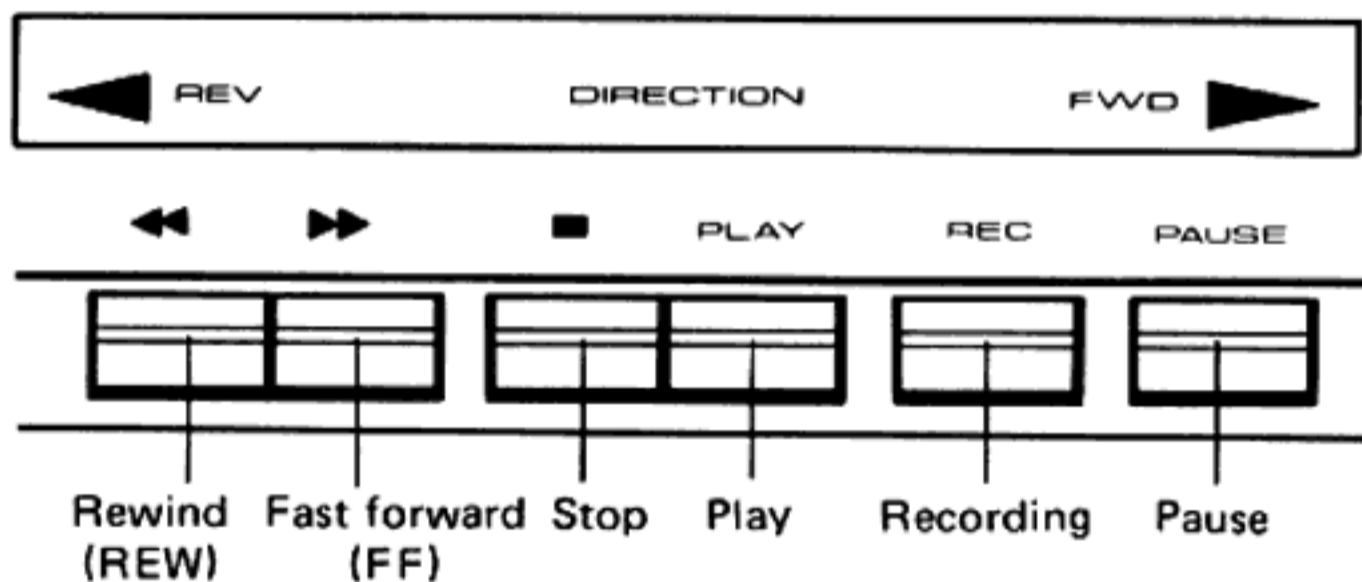

Play (record, playback)

Forward direction (tape moves from left to right)

1. Set the REVERSE MODE selector to .
2. Check that the tape is wound up on the left reel.
3. Depress the DIRECTION SELECTOR and make the FWD ► indicator come on.
4. The tape runs from left to right when the PLAY lever is depressed. If the REC lever is also depressed together with the PLAY lever, the deck will be set to the recording mode.

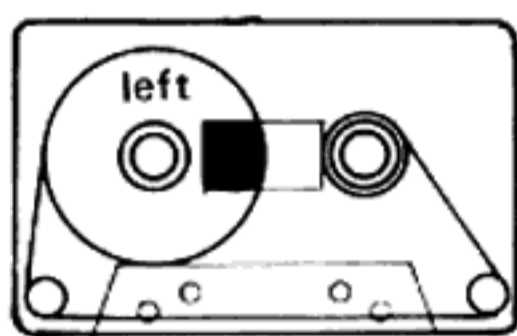

Forward Play, Record

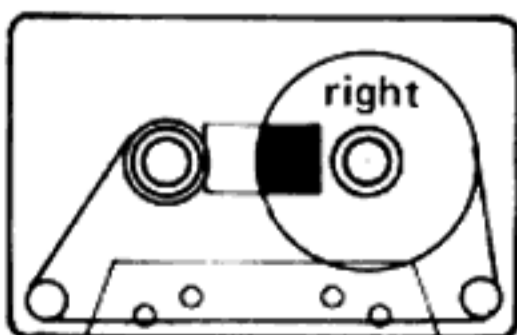

Reverse Play, Record

Reverse direction (tape moves from right to left)

1. Set the REVERSE MODE selector to .
2. Check that the tape is wound up on the right reel.
3. Depress the DIRECTION SELECTOR and make the REV ◀ indicator come on.
4. The tape runs from right to left when the PLAY lever is depressed. If the REC lever is also depressed together with the PLAY lever, the deck will be set to the recording mode.

Fast forward

1. Check that the tape is on the left reel.
2. The tape runs from left to right at high speed when the ►► lever is depressed for a fast forward operation.

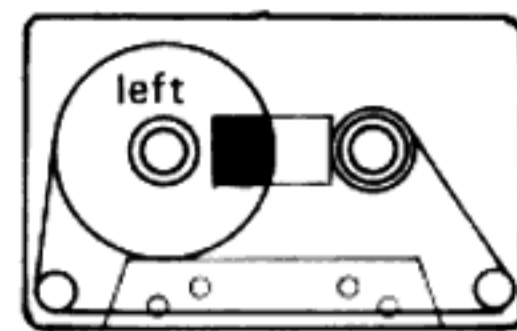

Fast forward

Rewind

1. Check that the tape is on the right reel.
2. The tape runs from right to left at high speed when the ◀◀ lever is depressed, and the tape is rewound.



Rewind

NOTES:

- You do not have to depress the ■ lever when selecting the next mode with the CT-F750.
- Do not depress more than one lever at a time except when recording and for pause mode.
- The operating levers will not be released if the power is turned OFF.
- During fast forward or rewind it is not possible to change over the tape direction even if the DIRECTION SELECTOR is depressed and the pause mode is not set even if the PAUSE lever is depressed.

STOP OPERATION

Stopping the tape

Depress the ■ STOP lever to stop tape motion. This action also releases the other operating levers (except the PAUSE lever).

PAUSE lever operation

1. The tape motion can be stopped during recording or playback by depressing the PAUSE lever. The play lever (and the REC lever if recording) is not released from its depressed position.
2. If the PAUSE lever is released, the tape will begin to run again.

NOTES:

1. When stopping the tape for a prolonged period of time, use the STOP (■) lever.
2. When using a pre-recorded tape to re-record a program, bear in mind that the pre-recorded sound will sometimes not be erased at the place on the tape where you set the deck to the pause mode.

The PAUSE lever comes in handy in the following instances:

- When the recording level is set.
- When you want to edit out some portions of a program during recording and then continue recording.

AUTO-STOP MECHANISM

The tape is automatically stopped and the operating levers released when the tape becomes completely wound onto one reel during each operating mode (Record, Playback, Fast forward, Rewind), even if the stop lever is not depressed.

NOTE:

The auto-stop mechanism swings into action several seconds after the tape has been wound up.

AUTO REVERSE AND AUTO REPEAT FUNCTIONS

When a cassette tape is usually loaded into a cassette deck, it travels in the forward direction (from left to right) and play begins. This action is known as forward playback. To play the reverse side (side B or side 2), the cassette has to be ejected, turned over and then re-loaded. This is the same as when listening to the other side of a record.

In contrast to forward playback, reverse playback refers to the operation where the tape travels in the opposite direction (from right to left). This deck comes with a direction selector so that reverse and forward tape travel can be selected during recording and playback. This means that there is no need to eject the cassette, turn it over and re-load it.

In addition, if the reverse mode selectors are selected and a tape recorded or played back, it is possible to play a tape through any number of times automatically, and also to record or play back both sides (side 1 and side 2).

ONE-WAY PLAYBACK, ONE-WAY RECORDING

For one-way recording or playback, depress the “” selector and then select the forward or reverse direction with the direction selector. With forward recording or playback, the tape travel is automatically stopped when the tape is fully re-wound on the right-hand reel. Conversely, if the reverse direction has been selected, the tape travel is automatically stopped when the tape is fully re-wound on the left-hand reel.

AUTO REVERSE

For automatic recording or playback of both sides of a tape, depress the “” selector and start the tape play in the forward direction. The tape moves from left to right and when the tape on the left-hand reel comes to the end, the tape direction is reversed, moving from right to left. It stops automatically at the tape end. The auto reverse mechanism will not work if the tape is started in the reverse direction.

AUTO REPEAT PLAY BACK

For automatic repeat playback, depress the “” selector and start playback. Playback is repeated until the STOP lever is depressed.







NOTES:

- When the tape is running in the auto reverse mode, remember that there will be a break lasting several seconds in recording and playback before and after the tape run changes from left to right or from right to left.
- Make sure that the REVERSE MODE selector  is depressed when the auto reverse and auto repeat functions are not being used.

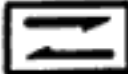
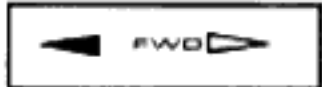
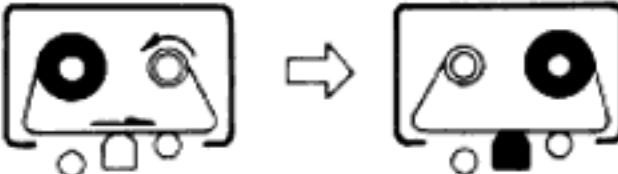
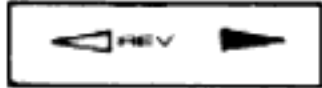
REVERSE MODE OPERATION

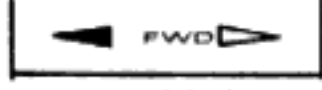
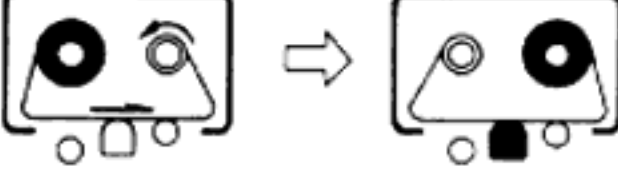
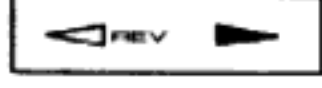
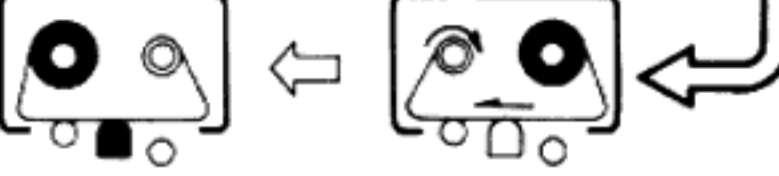
RECORDING OR PLAYBACK

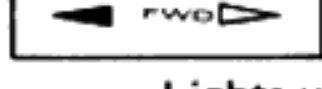
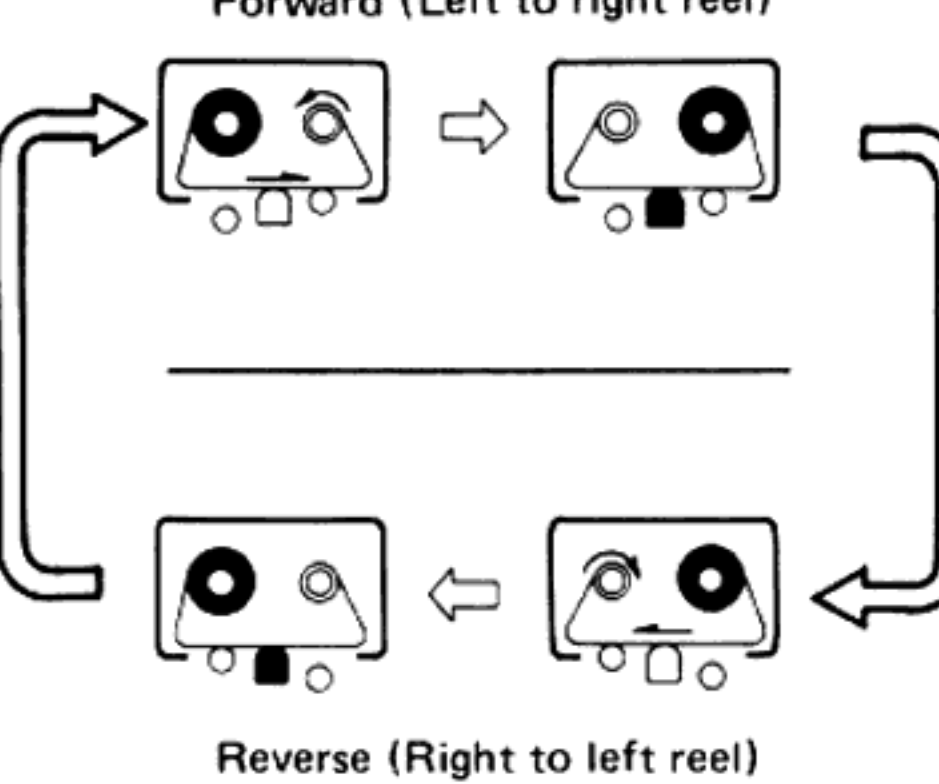
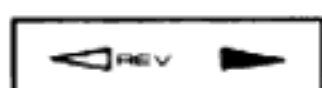
Reverse mode selector position	Tape direction	Direction lamp indicate	Tape run motion	
<p>One-side tape travel recording or playback</p> 	Forward mode	<p>DIRECTION</p>  <p>Lights up</p>	<p>Forward (Left to right reel)</p> 	The tape is recorded or playback in the forward direction and then it stops traveling when it comes to the end.
	Reverse mode	<p>DIRECTION</p>  <p>Lights up</p>	<p>Reverse (Right to left reel)</p> 	The tape is recorded or playback in the reverse direction and then it stops traveling when it comes to the end.
<p>Both sides recording or playback (Forward direction start only)</p> 	Forward mode	<p>DIRECTION</p>  <p>Lights up</p>	<p>Forward (Left to right reel)</p> 	Recording or playback starts in the forward direction and when the tape comes to the end, recording or playback proceeds in the reverse direction and the tape stops traveling when it comes to the end.
	Reverse mode	<p>DIRECTION</p>  <p>Lights up</p>	<p>Reverse (Right to left reel)</p> 	
<p>Repeat playback only</p> 	Forward mode	<p>DIRECTION</p>  <p>Lights up</p>		Auto reverse play back is repeated.
	Reverse mode	<p>DIRECTION</p>  <p>Lights up</p>		

OPERATING PROCEDURE

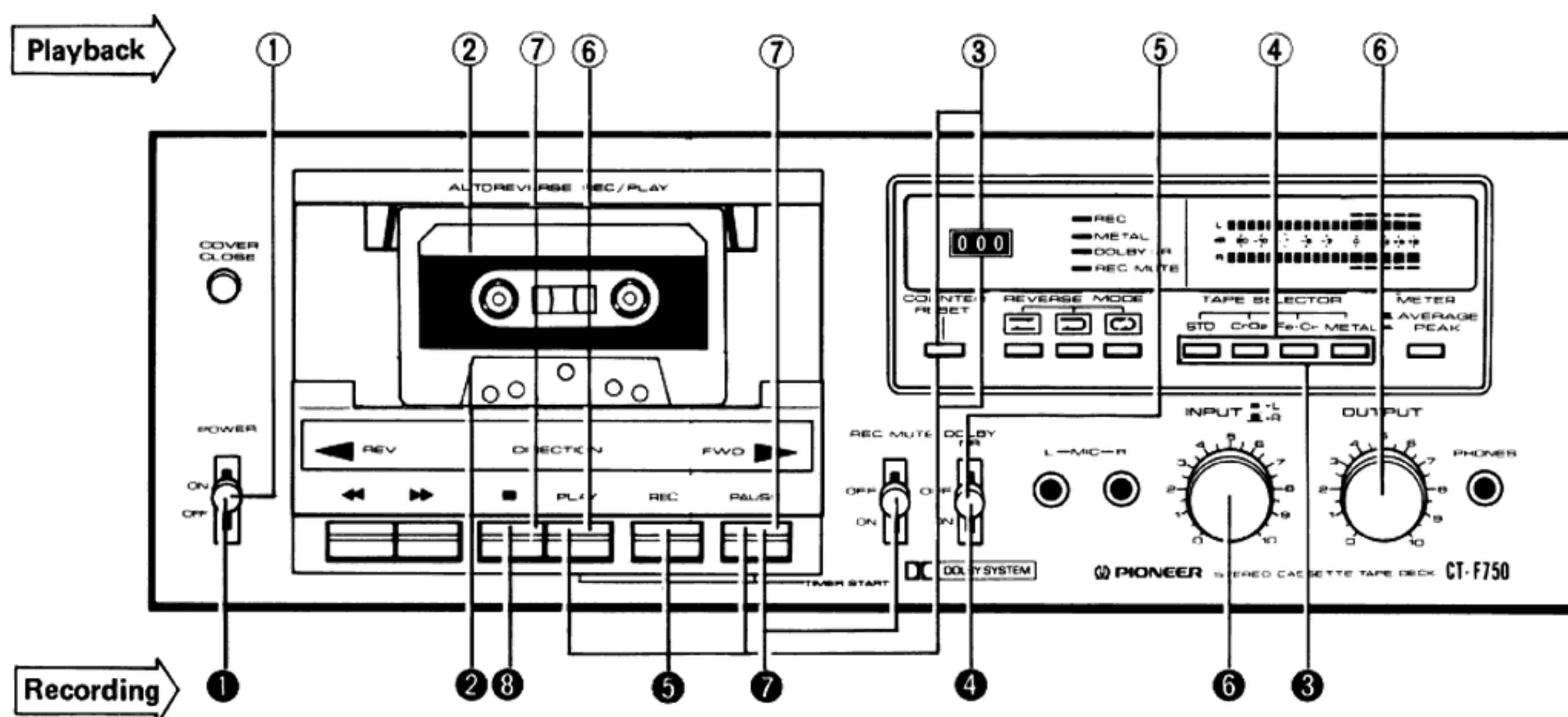

PLAYBACK

Set the switches and controls as follows before you switch the power on.

- Depress the COUNTER RESET switch to reset the tape counter display to "000".
- Set the METER switch to AVERAGE.
- Depress the REVERSE MODE selectors "  " button.
- Set the OUTPUT control to the "6" click position.
- Check that the head section is not dirty. If dirty, clean it.
- Set the stereo receiver's power switch and the TAPE MONITOR switch to ON to enable tape playback.

① Set the POWER switch to ON

② Load the cassette tape

Check that the tape is wound onto the left reel and load securely, following the instructions on page 5.

③ Set the tape counter to "000"

Depress the COUNTER RESET button and the counter will be reset to '000'.

LEVEL METER

The peak meter can cope more sensitively with sudden peak inputs than the level meter can. The level meter serves almost to simulate your sense of hearing, and it indicates the average strength of the input signals. Naturally, the peak input signal which is recorded has a higher level than the average level and so the standard '0dB' level meter level is set lower than the saturation level of the tape.

④ Select the TAPE selector position

If you are using a metal tape, depress the METAL switch; for a ferrichrome tape, depress Fe-Cr, for a chrome tape, depress CrO₂, and for a standard tape, depress STD. For details, refer to the table which is inserted into the operating instructions.

⑤ Set the DOLBY NR switch

Set this switch to ON when playing back a tape which has been recorded by the Dolby NR system. For further details on the Dolby NR system, refer to page 14.

⑥ Start playback

Depress the PLAY lever and the tape will start to run. Adjust the volume to the preferred level by rotating the OUTPUT control on the CT-F750, and the volume control on the stereo receiver.

⑦ Complete playback

When the tape is fully wound onto the right reel during playback, the PLAY lever will be released automatically. Depress the STOP lever if you want to stop the tape run during playback.

Depress the PAUSE lever for a temporary stop.

NOTE:

Refer to "Auto reverse and auto repeat functions" on page 6 for details on reverse and repeat playback. Depress the DIRECTION selector to change the tape direction during playback.

The peak meter is constructed so that its very fast response speed indicates peaks even if pulse-like signals are included in the input signals. When performing live recordings or when recording sources with a great many peak portions, make use of the peak meter and you will then ensure that the sound will not be distorted at the peak level.

RECORDING

Set the switches and controls as follows before you switch the power on.

- Set the METER switch to AVERAGE.
- Set the OUTPUT control to the "6" click position.
- Depress the REVERSE MODE selectors "  " button.
- Set the INPUT controls to the leftmost position.
- Inspect the head section for dirt. If dirty, clean it. (Refer to page 12.)
- Set up the program source (records, FM broadcast, microphone performance, etc.) which you intend to record.

1 Set the POWER switch to ON

2 Load the cassette tape

Check that the tape is wound onto the left reel, and load securely. Also check that the erasure prevention tabs on the cassette tape have not been broken off (see page 13).

3 Select the TAPE selector position

If you are using a metal tape, depress the METAL switch; for a ferrichrome tape, depress Fe-Cr, for a chrome tape, depress CrO₂ and for a standard tape, depress STD. For details, refer to the table which is inserted into the operating instructions.

4 Set the DOLBY NR switch

Set this switch to ON for recording using the Dolby NR system. For further details on the Dolby NR system, refer to page 14.

5 Stand-by for recording

Depress the PLAY and REC levers together and wait about five seconds for the leader tape to clear the heads. Then depress the PAUSE lever and set to the recording stand-by mode. The recording indicator (REC) will come on.

Depress the COUNTER RESET button and the counter will be reset to "000."

6 Set the recording level controls

Refer to following the section on "SETTING THE RECORDING LEVEL", and then adjust the INPUT controls.

7 Start recording

Release the PAUSE lever and the tape will then begin to run. Observe the recording level from time to time during recording on the level meter, and also check the tape run.

Depress the REC MUTE switch as long as required when creating non-recorded sound gaps between the programs on the tape.

8 Complete recording

When you have finished recording, depress the STOP lever and stop the tape. Depress the PAUSE lever for a temporary stop. When the tape is fully wound onto the right reel during recording, the PLAY and REC levers will be automatically released.

NOTE:

Set the deck up for one-side recording or reverse recording in accordance with the recording time and the program source which is to be recorded. For details, refer to "Auto reverse and auto repeat functions" on page 6.

SETTING THE RECORDING LEVEL

If you record a program source at a recording level which is unsuitable, the signal-to-noise ratio of the playback sound will deteriorate and the distortion will increase. Set the level according to the following procedure and safeguard against poor recordings.

1. Set the METER selector to AVERAGE.
2. Adjust the INPUT recording level controls so that the meter display is contained within a -5dB to 0dB (0 to $+3\text{dB}$ for metal tape) range when the program source has relatively high signal strength.
3. Set the METER switch to PEAK.
4. Re-adjust the INPUT recording level controls so that the meter display does not continuously exceed $+5\text{dB}$.
5. Set the METER selector to AVERAGE and re-adjust that the meter indication is less than 0dB (less than $+3\text{dB}$ for metal tape).

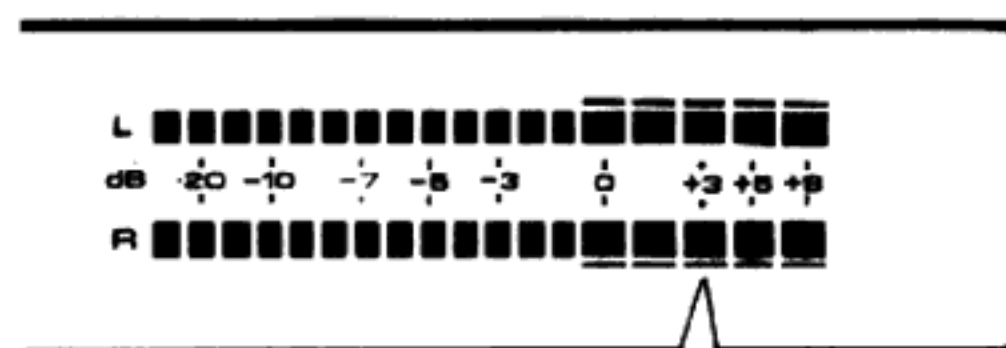

- The $+3$ mark indicates Dolby NR level.
- The maximum input level for metal tape should not exceed this position.

- If you record a sound source when the meter indication exceeds full scale, the playback sound will be distorted. Conversely, if the meter indication is too low (-20dB to -10dB), the signal-to-noise ratio will deteriorate and you will hear a great deal of noise when you play your recording back.
- If you adjust the recording level merely on the basis of the peak signal indication, the recording level will be set too low since you have adjusted it with the maximum input signal value. As a result, the signal-to-noise ratio will be downgraded.
- The signal level will fluctuate widely according to the program source, and so keep observing the meter indication while you are recording.

SETTING THE TAPE SELECTORS

At the same time as you select the bias in accordance with the tape you are using, it is necessary to compensate for the high-end of the frequency range. Set the TAPE selector in accordance with the type of tape you are using. Recommended positions of the TAPE selector is listed on the table which is inserted into the operating instructions.

USING THE REC MUTE SWITCH

This handy switch is used to cut out commercials when you are recording programs (FM) off the air, to create unrecorded sound sections between programs, and to eliminate the clicking noise made when the stylus descends onto the record with a disc recording.

When creating unrecorded sound sections between programs, depress this switch for about 5 seconds after one program has finished, and depress the PAUSE lever while the switch is depressed to ON. Once the tape has come to a halt, release the REC MUTE switch. The program source sound will be heard through the speakers during the recording but there will be no recording of the sound.

Depress the PAUSE lever immediately before the part of the program you do not want to record and then again immediately before the next program begins. Now continue with recording again.

If you are recording a program off a disc, depress the REC MUTE switch when the stylus descends onto the lead-in groove of the disc and release it immediately before play.

FOLLOW-ON RECORDING

You can record a new program source onto a pre-recorded tape which is playing in the deck if you depress the PLAY and REC levers together. This procedure is particularly effective for tape editing.

NOTE:

Check that the tape's erasure prevention tabs have not been broken off. You cannot record a new program source if they have. (Refer to page 13 and the section on "Erasure Prevention Tabs").

ERASING RECORDED SOUND

- To completely erase a program which you have already recorded turn the INPUT recording level controls to their leftmost position, and run the tape with the deck set to the recording mode.
- When recording a new program over a pre-recorded tape, the previous sound will be automatically erased and the new program will be recorded over it.

MICROPHONE RECORDING

STEREO RECORDING

As shown in Fig. 2, use a stereo microphone or two identical microphones, and connect the one for the left channel to the L MIC jack and the one for the right channel to the R MIC jack. For the actual recording, refer to page 9 and the section on "RECORDING."

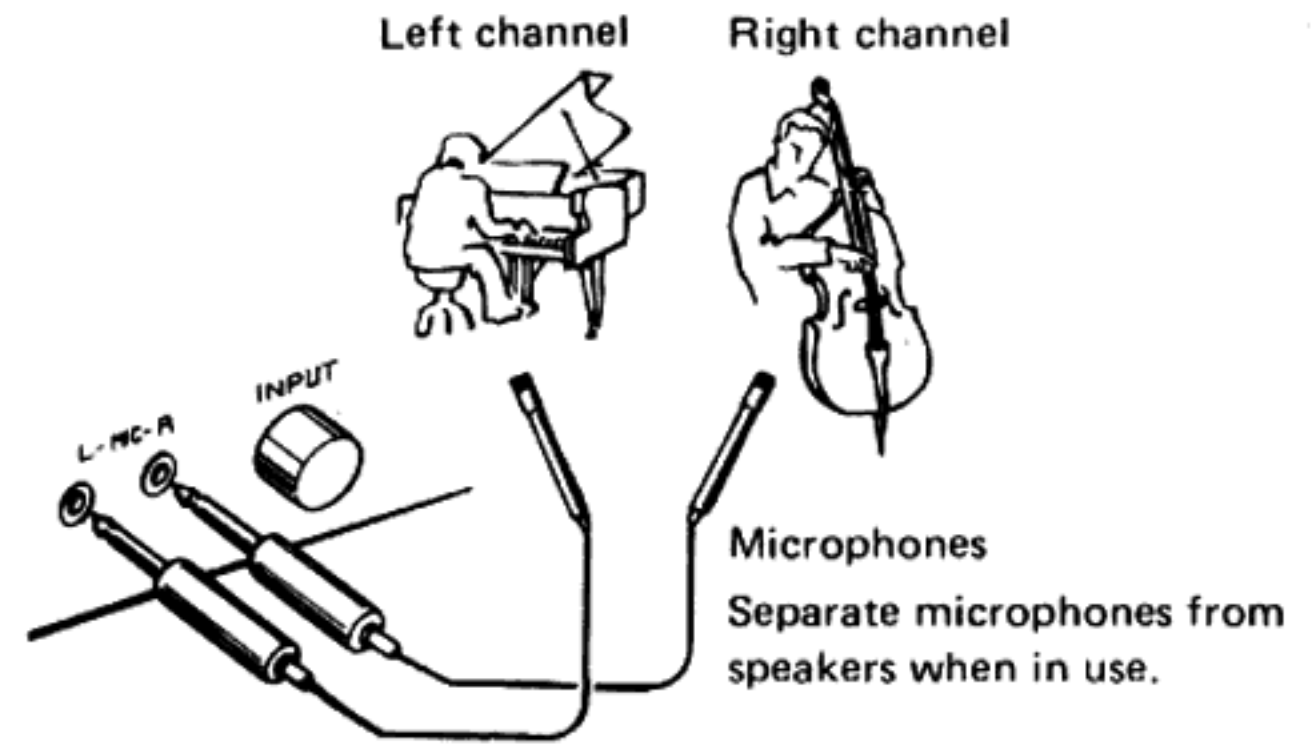

Fig. 2

Points to bear in mind

- Use dynamic or electret microphones.
- Make sure that the connecting cord for a high-impedance microphone is less than 5 meters long.
- When you want to check the quality of the recording or what is being recorded, it is a good idea to use the headphones.
- Monitoring the recording with the speakers very often gives rise to howl so use the microphones as far away from the speakers as possible.
- Do not connect a microphone to the HEADPHONES jack, as the microphone may be damaged.

OPERATIONS WITH THE TIMER

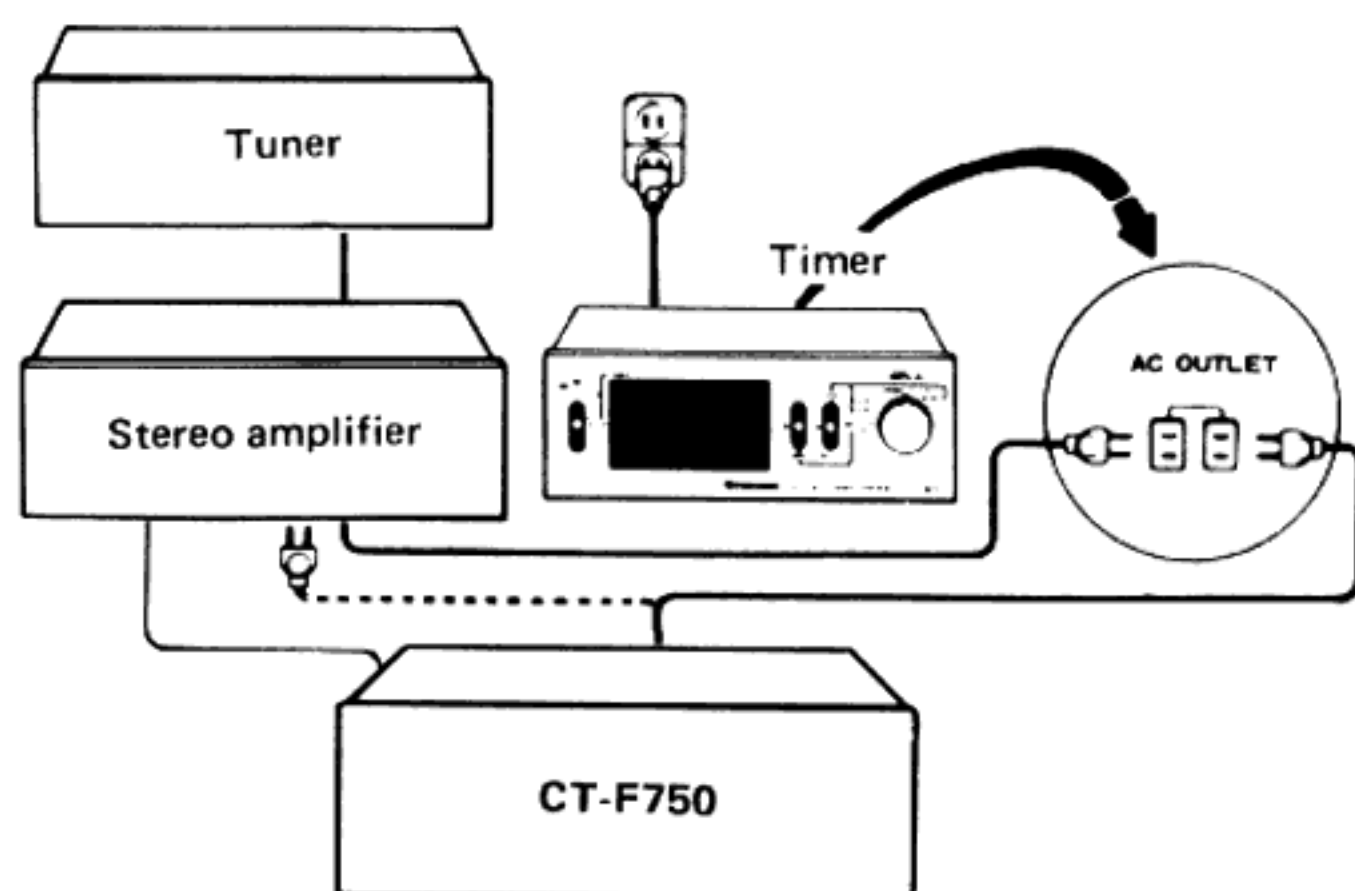

Fig. 3

UNATTENDED RECORDING

You can use the timer switch, which is sold separately, to automatically record an FM broadcast or other program source at a specified time. This is convenient for recording programs when you are out or asleep.

1. As shown in Fig. 3, connect the CT-F750's power cord to the timer. Also connect the stereo system's power cord of the stereo system (tuner, amplifier) so that the stereo system's ON/OFF functions are controlled by the timer.
2. Set the power switches of the CT-F750 and the stereo system's to ON, and then select the broadcasting station whose program you want to record.
3. Set the CT-F750 PAUSE lever to the depressed position.
4. Follow steps ① to ⑥ in the section on "RECORDING" on page 9 and set the recording level. Rewind the tape back to the point at which you want to start recording.
Set the deck up for one-side recording or reverse recording in accordance with the recording time and the program source which is to be recorded. For details, refer to "Auto reverse and auto repeat functions" on page 6.
5. Set the timer so that the power will come on at the prescribed time. The power to the other audio components goes off.
6. Make sure that the PAUSE lever is in the pause position.

7. At the desired time, the power will go on, automatically releasing the PAUSE lever, and recording will begin after five seconds. When the tape is completely wound onto the reel, the auto-stop mechanism will be activated and the tape will stop. The timer will now operate to switch off the power to the CT-F750 and the stereo system.

NOTES:

- With unattended recording or wake-up playback, make absolutely sure that the cassette tape is loaded with the tape wound up on the left reel.
- Turn the amplifier's volume control right down so that the sound is not heard through the speakers while you are out.
- For more details on the connections, refer to the timer's instruction booklet.
- Set the time on the timer so that the power to the CT-F750 and stereo components is switched off after the tape is fully wound onto the right reel.
- Some timers do not allow more than one hour unattended recording.

WAKE-UP PLAYBACK

You can have the CT-F750 play back a pre-recorded tape automatically at a desired time. You can set the timer so that the tape's music wakes you up instead of an alarm clock.

1. Connect the CT-F750 as shown in Fig. 3, depress the PAUSE lever and then set the deck to the playback mode by following the instruction ① to ⑥ of "PLAYBACK" on page 8.
2. Set the timer so that the power is switched on at the appointed time.
3. Depress the PAUSE lever.
4. At the desired time on the timer, the CT-F750's PAUSE lever is returned to its original position and playback begins.

MAINTENANCE

Follow the maintenance instructions below to keep your deck working in tip-top condition.

CLEANING THE HEAD SECTION

Fig. 4 shows that the head section is composed of the heads, capstans and pinch rollers, and with extended use these parts accumulate dust, dirt and grease easily as the tape runs.

If this assembly gets dirty, the contact between the tape and the surface of the heads is impaired and this downgrades the sound quality and stereo balance, and it also leads to unstable operation. To prevent this, clean the head section and the surrounding parts regularly with the accessory cleaning swabs or with a soft cloth dipped in the cleaning fluid commercially sold in the market.

You will find that it is easier to clean the pinch roller if you depress the cassette detection pin and the PLAY lever. After the cleaning, depress the ■ (STOP) lever to bring the mechanism to a stop.

DEMAGNETIZING THE HEADS

The recording head becomes magnetized when you use the tape deck for prolonged periods of time. This results in noise being generated and the treble dropping off during recording and playback. The recording head should therefore be regularly demagnetized with the head eraser, which is sold separately. For further details, refer to the head eraser's instructions booklet.

CLEANING THE FRONT PANEL, DUST COVER

Use a soft cloth to wipe off dust and grease from the front panel and dust cover. When these parts are very dirty, dip the soft cloth in a small amount of neutral cleanser, remove the dirt and wipe with a dry cloth. Never use volatile spirits like thinners, benzine or alcohol because they will damage the panel's finish.

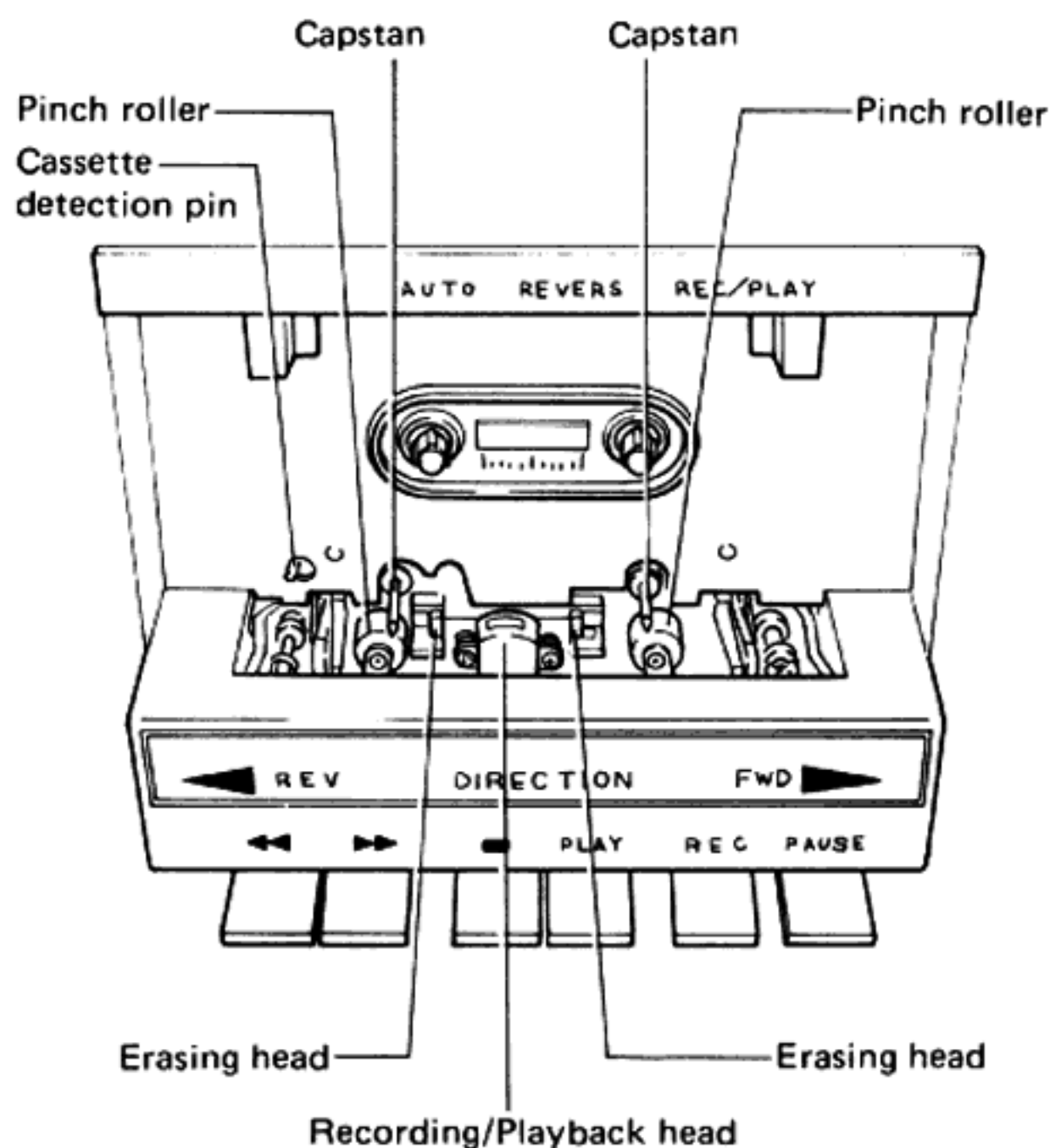

Fig. 4

Moisture forms in the operating sections of this model and the model's performance will be impaired if the model is brought from cool surroundings into a warm room or if the temperature of the room rises suddenly. To prevent impairing performance, let the model stand in its new surroundings for about an hour before switching it on, or ensure that the room temperature rises gradually.

CASSETTE TAPES

Cassette tapes are manufactured according to international standards governing their construction, and they are generally classified according to their tape performance and recording time.

Performance classifications

Standard type	Low-noise type	High-performance type
<ul style="list-style-type: none"> • Standard tape • Dynamic tape 	<ul style="list-style-type: none"> • Low-noise tape • Low-noise, high-output tape 	<ul style="list-style-type: none"> • Chrome tape • Ferrichrome tape • Metal tape

Recording time classifications

Cassette tape designation	Recording time (minutes)	
	One side	Both sides
C-30	15	30
C-46	23	46
C-60	30	60
C-90	45	90
C-120	60	120

The size of the cassette tapes is the same but their playing (and recording) times differ according to the tape thickness (length).

The C-60 and C-90 tapes are most commonly used. The C-120 tapes are not recommended because their mechanical and electrical specifications vary.

CHECK CASSETTE BEFORE USE

Slack or protruding tapes

If the tape protrudes from the cassette as shown in Fig. 5 or is slack, the tape may run without passing through between the capstan and the pinch roller and so may be damaged. Take up the slack by inserting a pencil through the reel hub and turning it as indicated in the figure.

Some tapes provide a tape stopper to prevent tape slack. Make sure that you remove the tape stopper before inserting the tape into the deck.

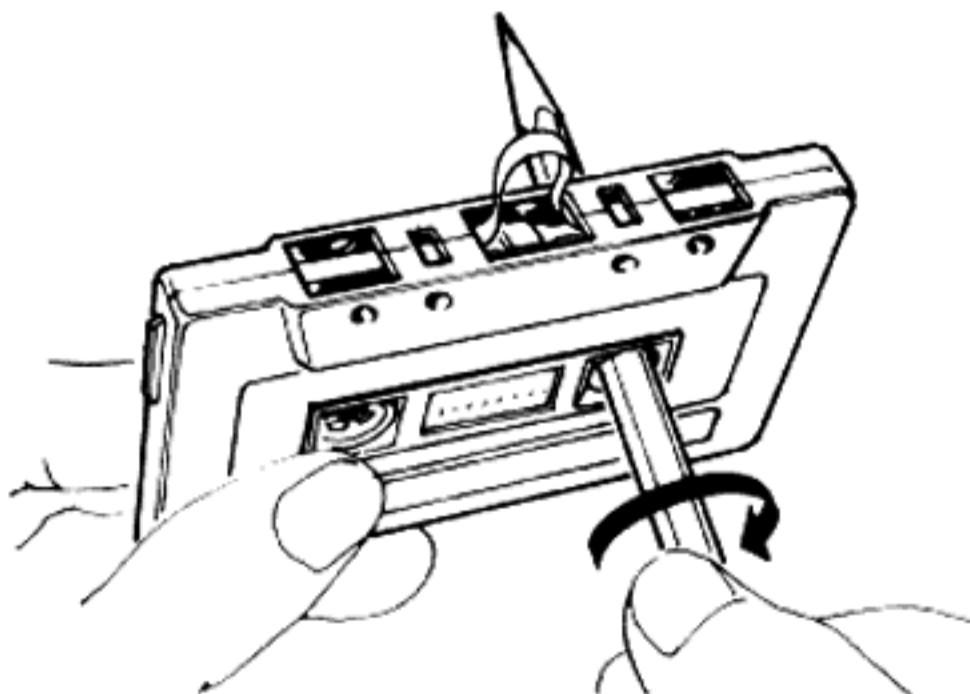

Fig. 5

Erase prevention tabs

Cassette tapes are provided with erase prevention tabs, as shown in Fig. 6, which act as a protection device to prevent the accidental erasure of a recording which you want to keep. If you remove the tabs, as shown in Fig. 6, with a screwdriver you will be able to prevent erasure if you accidentally set the CT-F750 to the recording mode by depressing the REC lever.

To re-record, cover the tab opening with a double layer of adhesive tape (Fig. 7).

NOTE:

Cassette tapes are provided with two tabs (A or 1 and B or 2) so you can protect the recordings on both sides.

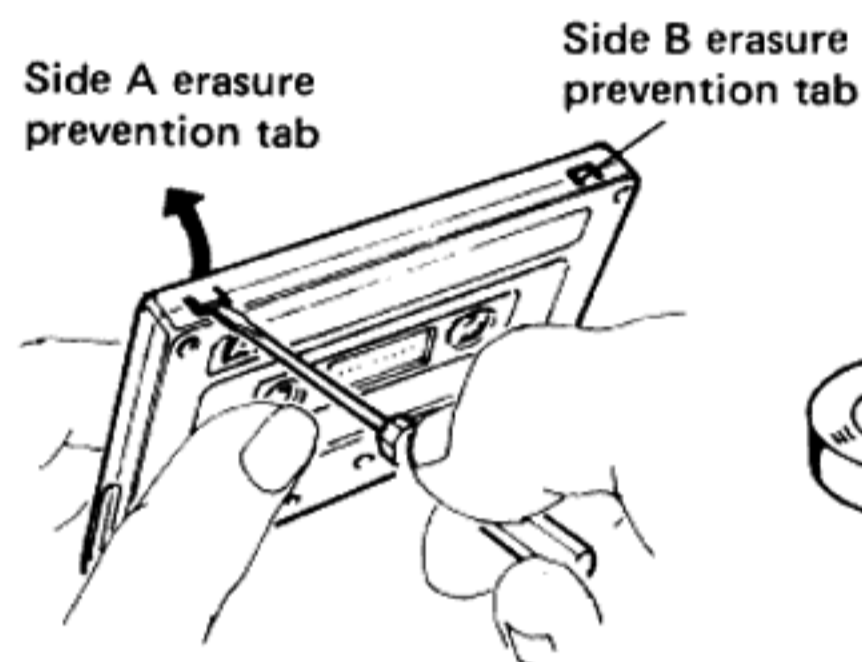

Fig. 6

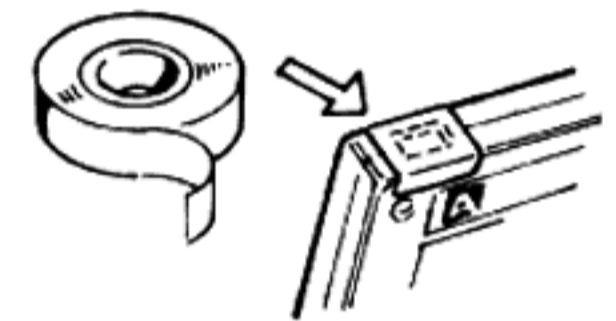

Fig. 7

HINTS ON HANDLING CASSETTE TAPES

• Check the tape before recording

Before starting to use the tape for recording, load it. Then set the tape deck to fast forward and rewind. This will safeguard the deck from damage caused by irregularities in the tape winding.

• Take care with the leader tape

A leader tape is attached to the beginning of the cassette tape (you cannot record on it). It takes about 5 seconds for it to pass through, so bear this point in mind when recording.

• Do not load a cassette immediately after cleaning the heads

Do not load a cassette immediately after you have cleaned the heads until the head surfaces are completely dry (this takes 2-3 minutes).

• Storing cassette tapes

Do not store your cassette tapes without putting them in their cases since dust and dirt will adhere to them. Always store in a location which is free from dust, dirt, oil, and magnetic effects.

THE DOLBY NR SYSTEM

A cassette tape travels at one quarter of the speed of an open-reel (19cm/sec, 4-track) tape, and its track width is only 60 percent in comparison. The cassette tape is thus clearly at a disadvantage with respect to the signal-to-noise ratio.

The Dolby NR system is designed to reduce the noise called hiss which is inherent in tapes, and it is effective in upgrading the signal-to-noise ratio. It is so effective, in fact, that it is now indispensable to cassette decks.

The basic principle of the Dolby NR system is as follows: when signals with a relatively low level are recorded, the Dolby NR circuitry enhances the signals in the high-frequency range which has most of the hiss components, and these signals are then recorded. When they are played back, the circuitry attenuates only those components which were enhanced during recording. This returns the signal components to the normal level, and the hiss is reduced (by a maximum of 10dB) during playback only for that level which was attenuated. When the signal is relatively high level, the S/N ratio is sufficient and so the operation of the Dolby NR

system is not necessary. The Dolby NR system operates automatically in accordance with the signal level, as shown in the figure. Furthermore, if the Dolby NR system is used for recording, the recording level can be set relatively low which enables almost distortion-free good sound quality tape recordings.

Operating precautions

- The adjustment of the recording level is basically the same as when the Dolby NR system is not used.
- In order to make the most of the effect of the Dolby NR system, choose a program source with as little noise as possible.
- If you have used the Dolby NR system to record a program, make sure that you use it when playing the same program back.
- Playing back a normally recorded tape with the Dolby NR system and playing back normally a tape which was recorded by the Dolby NR system will result in an unnatural reproduction of the sound on the tape.

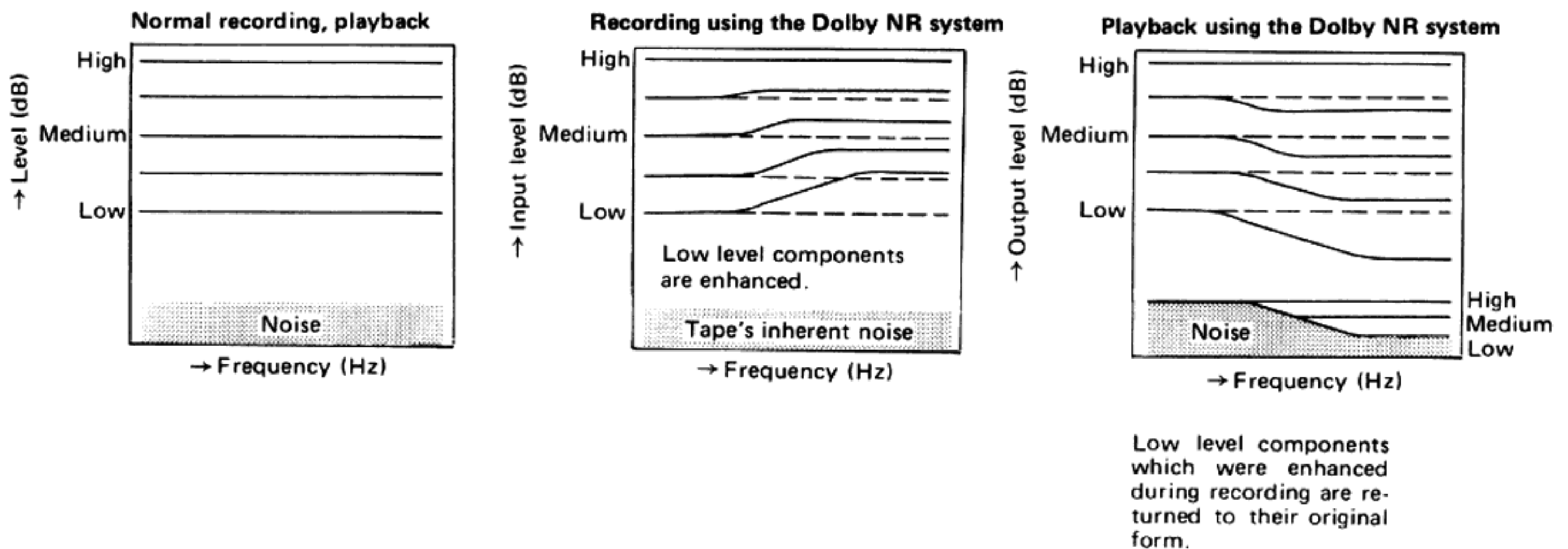

SPECIFICATIONS

Systems Compact cassette, 2-channel stereo
 Motor High torque DC servo motor x 1
 Heads Recording/playback head x 1
 Erasing head x 2
 Fast Winding Time Approximately 90 seconds
 (C-60 tape)
 Wow and Flutter No more than 0.05% (WRMS)
 No more than ± 0.17% (DIN)
 Frequency Response
 -20dB Recording:
 Standard, LH tapes 20 to 15,000Hz
 (25 to 14,000Hz ± 3dB)
 Ferrichrome tape 20 to 17,000Hz
 (25 to 16,000Hz ± 3dB)
 Chromium dioxide tape 20 to 17,000Hz
 (25 to 16,000Hz ± 3dB)
 Metal tape 20 to 18,000Hz
 (25 to 17,000Hz ± 3dB)
 0dB: Recording:
 Chromium dioxide tape 20 to 8,000Hz
 Metal tape 20 to 11,000Hz
 Signal-to-Noise Ratio Dolby NR OFF; More than 59dB
 Dolby NR ON; More than 69dB
 (over 5kHz)
 Harmonic Distortion No more than 1.2% (0dB)
 Inputs (Sensitivity/Maximum allowable input/Impedance)
 MIC (L, R); 0.3mV/100mV/10 kilohms, 6mm diam. jack
 (Reference MIC impedance; 250 ohms to 10 kilohms)
 LINE x 2; 65mV/25V/56 kilohms Pin jack
 Outputs (Reference level/Maximum level/Load impedance)
 LINE x 2; 450mV/640mV/50 kilohms Pin jack
 HEADPHONES x 1; 60mV/85mV/8 ohms, 6mm diam. jack
 Semiconductors
 Amplifier section
 Transistors x 41(HE, HB models)
 Transistors x 40(D model)
 Diode x 60, ICs x 16
 Motor control section IC x 1, Diode x 2
 Subfunctions
 • Recording/Playback automatic reverse with Reverse mode selector
 • Fluorescent display level meter with peak/average selector (-20 to + 8dB)
 • 4 position tape selector (STD/METAL/CrO₂/Fe-Cr) with LED indicator lamp for metal tape
 • Dolby NR system (ON/OFF) with LED indicator lamp
 • REC muting function with LED indicator lamp
 • Standby mechanism with unattended recording
 • Output level control with click-stop for reference playback level
 • Cassette compartment illumination (Remaining tape marker)
 Power Requirements AC 120V, 220V, 240V (switchable)
 50/60Hz (D, D/G models) or
 AC 220V, 240V (switchable) 50/60Hz
 (HE, HB models)
 Power Consumption 32 watts
 Dimensions
 HE, HB models 420(W) x 150(H) x 335(D)mm Max.
 16-9/16 x 5-15/16 x 13-3/16 in.
 D model 420(W) x 150(H) x 340.5(D)mm Max.
 16-9/16 x 5-15/16 x 13-13/32 in.
 D/G model 451(W) x 161(H) x 340.5(D)mm Max.
 17-3/4 x 6-11/32 x 13-13/32 in.

Weight
 HE, HB, D models 8.0kg (17 lb 10 oz)
 D/G model 8.4kg (18 lb 8 oz)
 Furnished Parts Stereo connecting cords with pin plugs x 2
 Head cleaning swabs x 3
 Fuse (D, D/G model only) x 1
 (1A or 500mA)
 Operating instructions x 1
 Operating instructions (HE model only) x 2

NOTE:
 Specifications and the design subject to possible modification without notice due to improvements.

- NOTES:**
- Reference Tapes: Standard & LH: DIN 45513/BLATT6 or equiv.
 : CrO₂: DIN 45513/BLATT7 (CrO₂) or equiv.
 - Reference Recording Level: Meter 0dB indicating level (160 nwb/m magnetic level = Philips cassette reference level)
 - Reference Signal: 333Hz
 - Wow & Flutter: • JIS [3kHz, with acoustic compensation (weighted), rms value] DIN [3,150Hz, with acoustic compensation (weighted) PEAK value]; DIN 45507
 - Frequency Response: • Measured at -20dB level, DOLBY NR OFF, level deviation is ±6dB without indication.
 - Signal to Noise Ratio: • Measured at the third harmonic distortion 3% level, weighted.
 - Sensitivity: Input level (mV) required for reference recording level with input (REC) controls set to maximum.
 - Maximum Allowable Input: While decreasing settings of input (REC) level controls and increasing level at input jacks, this is the maximum input level (mV) at the point where recording amplifier output waveform becomes clipped.
 - Reference Output Level: Playback output level when meter indicates 0dB.
 - Maximum Output Level: Playback output level with respect to reference recording level when output (PLAY) level control is set to maximum.
 - This model doesn't employ with a recording/playback connector (DIN-type).

Dimensions
 D, HE, HB models only;

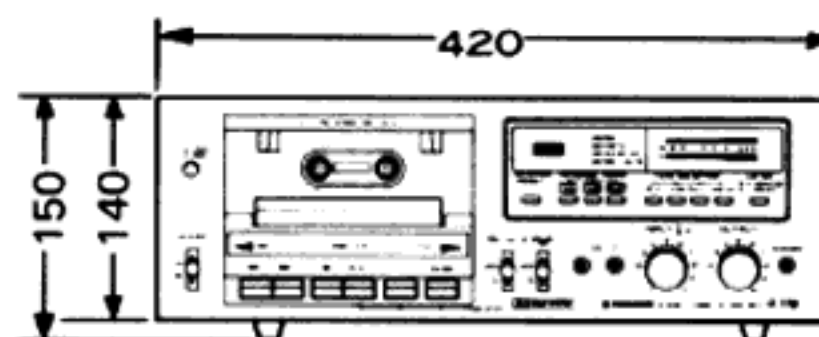

D/G model only;

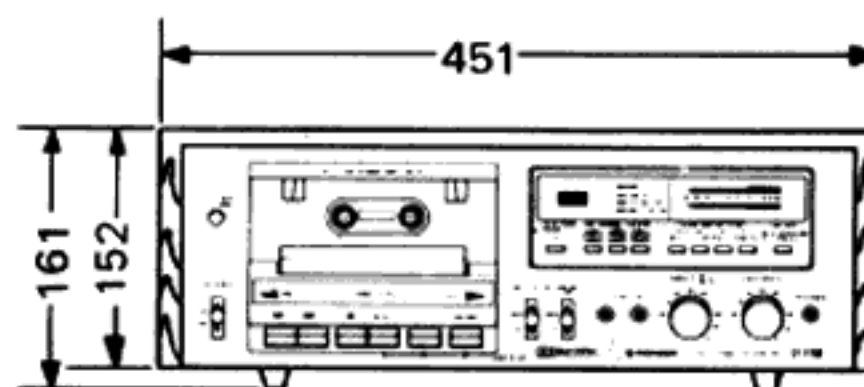

Unit: mm

IMPORTANT—LINE VOLTAGE

CT-F750 are designed to accept different line voltages, according to the country in which they are to be used, although the operation of the various models is the same in every respect. Fig. A shows the model designed to operate at any of two pre-selected voltages (220V, 240V).

Fig. B shows the model designed to operate at any of three selected voltages (120V, 220V, 240V). Line voltage and fuse can be changed and set as follows:

220V and 240V MODEL

1. Disconnect the power cord.
2. Loosen the screw on the selector plug with a Phillips screwdriver, then take out the plug.
3. Re-install the plug with its cutaway section exposing the correct voltage indication as illustrated (Fig. A).
4. Tighten the mounting screw.

120V, 220V and 240V MODEL

1. Disconnect the power cord.
2. Use a Phillips screwdriver to take out the fuse cap and fuse (Fig. B).
3. Pull out the selector plug from the socket.
4. Put the selector plug back so that the appropriate line voltage marking can be seen through the cut in the edge of the plug.
5. Change the fuse in accordance with the table.
6. Replace the fuse and fuse cap.

220V, 240V model

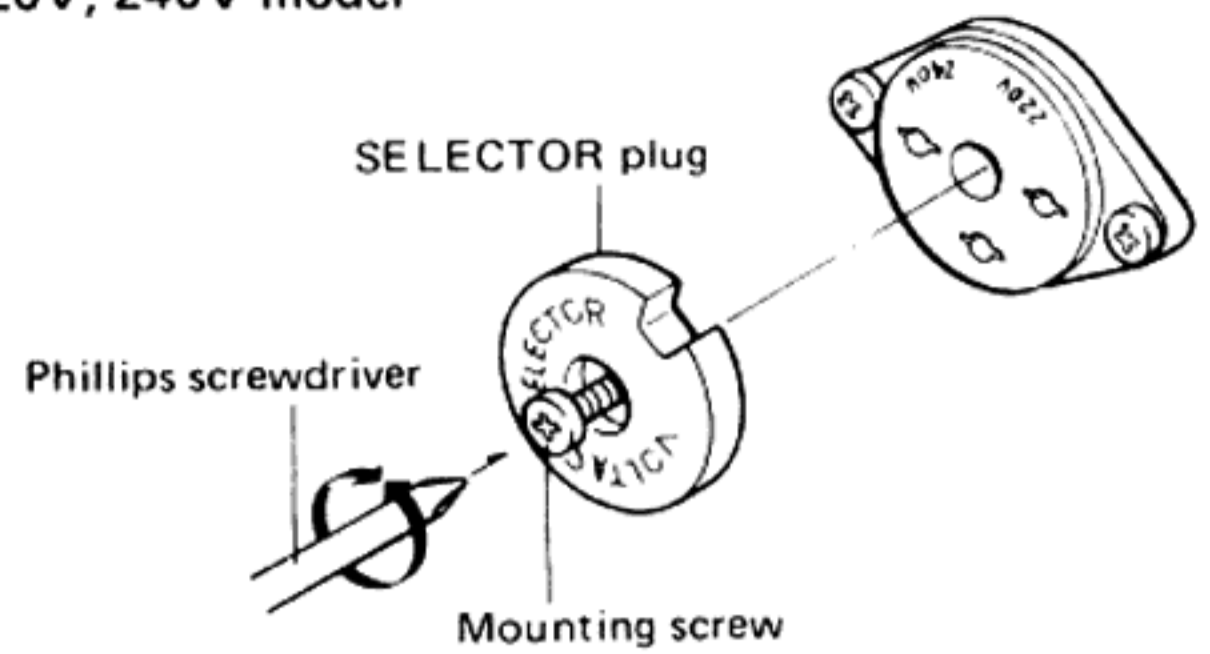
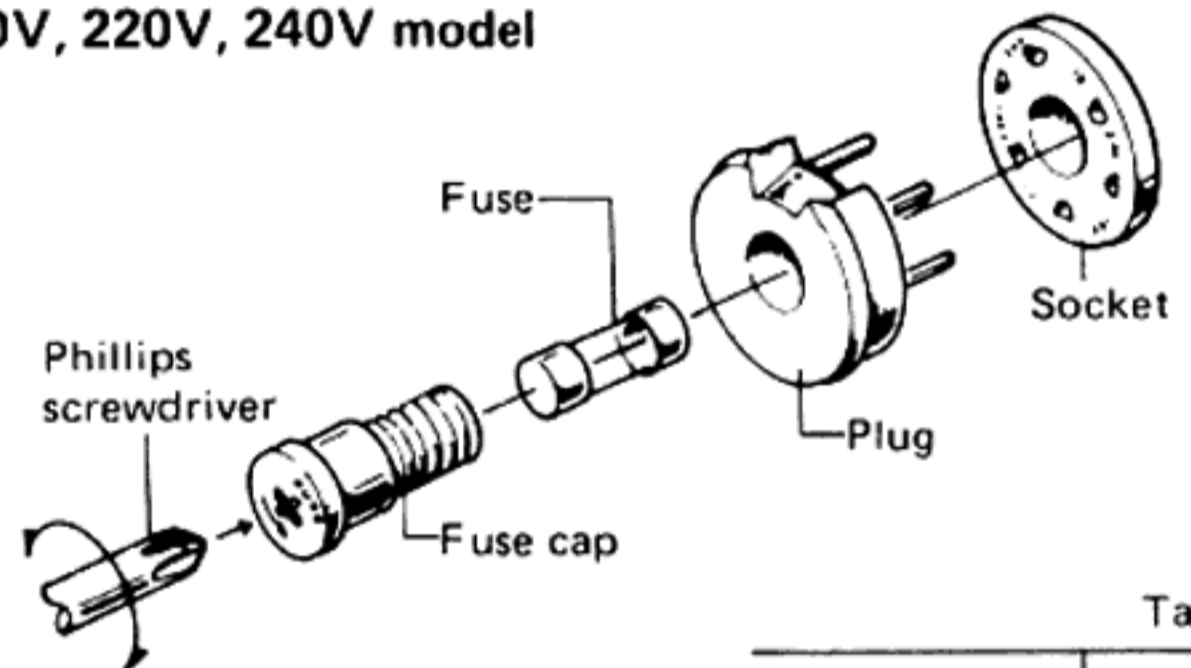

Fig. A

120V, 220V, 240V model



VOLTAGE	FUSE
120V	1A
220V 240V	500mA

Fig. B

To prevent electric shock, do not remove cover. No user serviceable parts inside, refer servicing to qualified service personnel.

Always disconnect all the equipment from the mains supply when disconnecting the signal leads. The power cord should be connected last, make sure that the power switch is off.

Unplug the set from the wall socket when it is not to be used for an extended period of time.

FOR USE IN UNITED KINGDOM AND AUSTRALIA

CAUTION 240V: Mains supply voltage is factory adjusted at 240V.

FOR USE IN UNITED KINGDOM

The wires in this mains lead are coloured in accordance with the following cord:

Blue: Neutral
Brown: Live

As the colours of the wires in the mains lead of this apparatus may not correspond with the coloured markings identifying the terminals in your plug proceed as follows.

The wire which is coloured blue must be connected to the terminal which is marked with the letter N or coloured black.

The wire which is coloured brown must be connected to the terminal which is marked with the letter L or coloured red.