

SERVICE MANUAL

HIGH-POLYMER STEREO HEADPHONES SE-700

1. SPECIFICATIONS

Speakers two 8.5 μ piezoelectric high-polymer film diaphragm
Static capacity 0.07 μ F
Sound pressure level 100 dB/3V
Maximum input power 30V
Frequency response 20 to 20,000Hz
Connection cord and plug
3 meter meshwork cord with 6.3mm ϕ 3-P plug
Weight 295g/10 oz. (without connection cord)
345g/12 oz. (with connection cord)

NOTE: Specifications and design subject to possible modifications without notice for improvement.



CAUTION:

More than 30 minutes's exposure of a high polymer diaphragm used in the SE-700 will affect its property, resulting in impairing the tone quality.

Also never touch the diaphragm directly with the fingers but it will go ineffective.

With these things in mind, be careful when disassembling the SE-700 for replacement of the cord, for example.

2. EXPLODED VIEW AND PARTS LIST

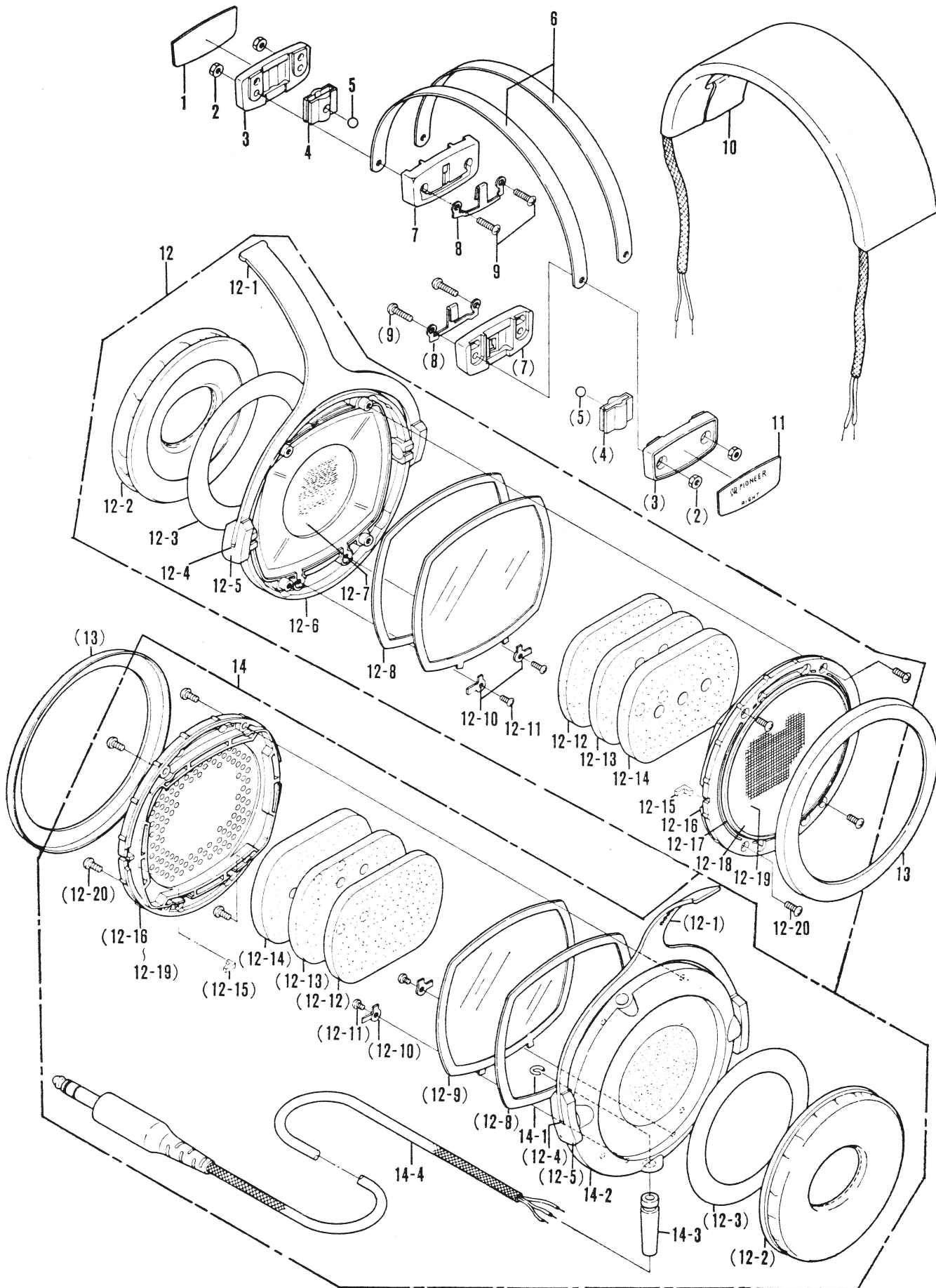

3. 3-P PLUG WITH CORD REPLACEMENT

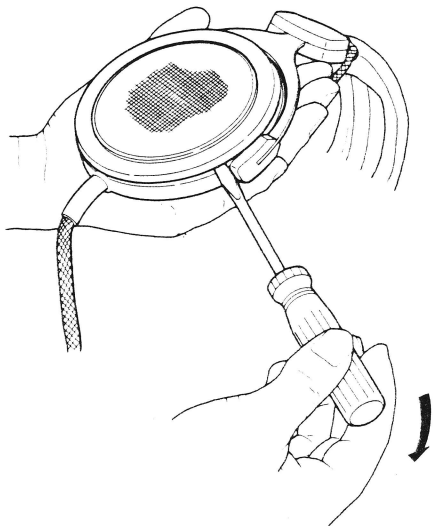

Fig. 1

Wrench ring A with a screwdriver. Once the hermetically-sealed ring A has been wrenched, it will become uneven and scratched. Therefore, replacement with a new ring will be required.

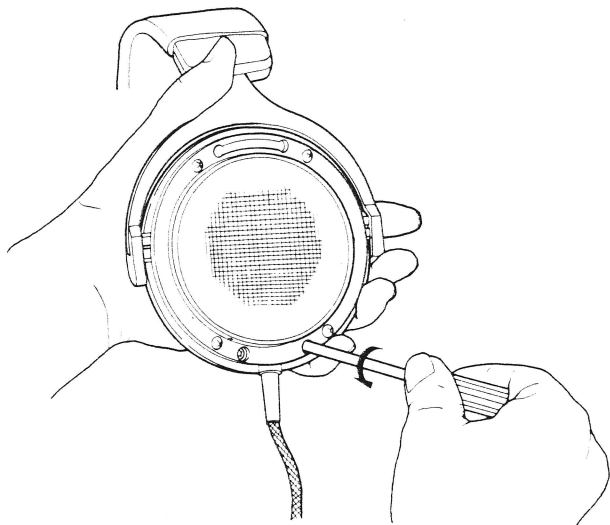

Fig. 2

Loosen two screws. There is no need to remove them.

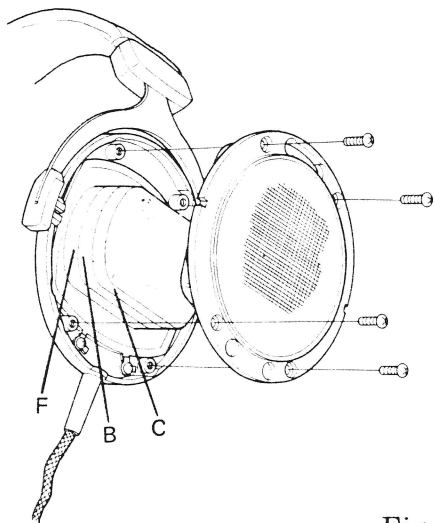

Fig. 3

Remove all four screws and take out of the case.

Then remove three sheets of polyurethane. When putting them back again, follow the order of sheets F, B, C, as shown in Fig. 3 .

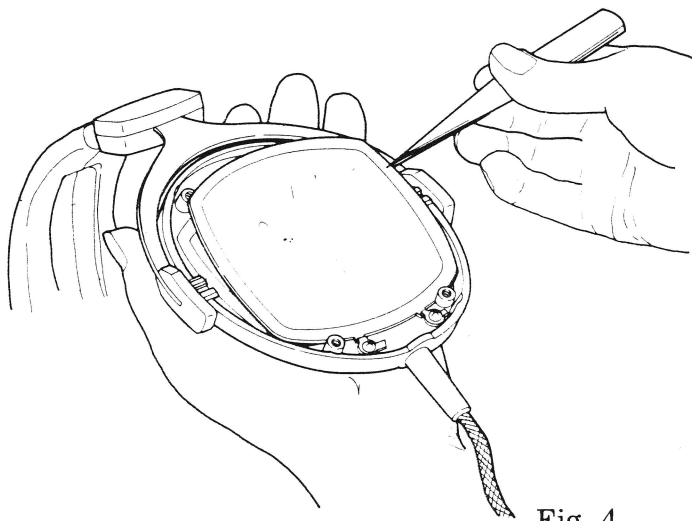

Fig. 4

Remove the diaphragm, with care taken never to touch it. Remember that even light touching will render the diaphragm ineffective.

Be sure not to expose the diaphragm for more than 30 minutes.

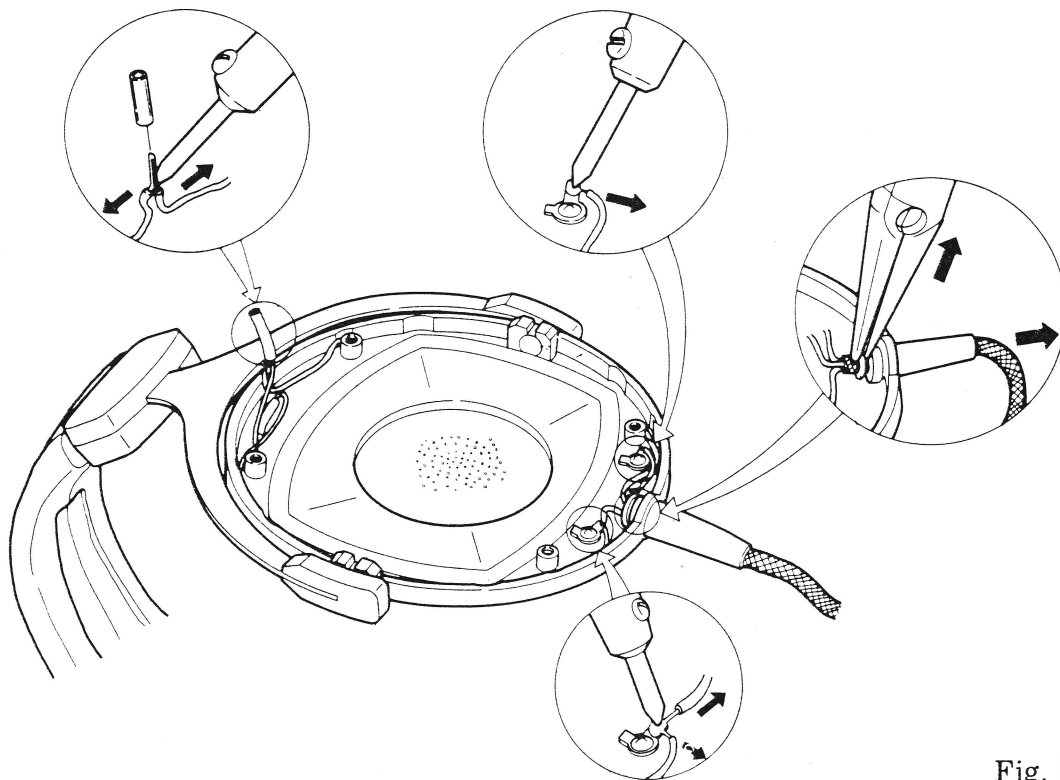

Fig. 5

Unsolder three points with a soldering iron as shown in Fig. 5

Clip cord metal stopper and pull out the cord.

PART LIST

NOTICE: Any parts asterisked (*) are subject to being not supplied.

Key No.	Descriptions	Part No.
1	Name plate (L)	SAL-452-0
2	Nut M3	
3	Band holder A	SNK-156-0
4	Slaider	SNK-159-0
5	Steel ball 4φ	
6	Head band A	SNB-104-0
7	Band holder B	SNK-157-0
8	Plate spring	SNB-108-0
9	⊕ Panhead screw M3 x 8	
10	Head pad	SCD-494-0
11	Name plate (R)	SAL-453-0
12	Headphone unit assembly (R)	SXC-110-0
12-1*	Head band B	SNB-105-0
12-2	Ear pad	SCD-485-0
12-3	Adhesive tape	SEH-001-0
12-4*	Band stopper pin	SNB-109-0
12-5*	Shaft	SNK-160-0
12-6*	Bass (R)	SNK-155-0
12-7*	Punching net	SNB-116-0
12-8*	Packing B	SEB-025-0
12-10*	Terminal	SKF-032-0
12-11*	⊕ panhead screw M2.6 x 4	
12-12*	Acoustic material F	SEF-182-0
12-13*	Acoustic material B	SEC-179-A
12-14*	Acoustic material C	SEC-179-B
12-15	Stopper	SNB-114-0
12-16*	Case	SNK-161-0
12-17*	Metal ring B	SNB-103-0
12-18*	Mesh cover	SNB-111-0
12-19*	Net	SCD-487-0
12-20*	⊕ panhead screw M3 x 6	
13	Metal ring A	SNB-102-0
14	Headphone unit assembly (L)	SXC-109-0
14-1	Cord stopper	SNB-113-0
14-2*	Bass (L)	SNK-154-0
14-3*	Rubber bush	SNK-158-0
14-4	Cord with 3-P plug	SKM-017-0
	Packing case	SHG-107-0
	Packing inner case	SCC-241-0
	Operating instructions	SRB-092-0

PIONEER ELECTRONIC CORPORATION

4-1, 1-Chome, Meguro, Meguro-ku, Tokyo 153, Japan

U.S. PIONEER ELECTRONICS CORPORATION

75 Oxford Drive, Moonachie, New Jersey 07074, U.S.A.

PIONEER ELECTRONIC (EUROPE) N.V.

Meir-Center Meir 21, 2000 Antwerp, Belgium

PIONEER ELECTRONICS AUSTRALIA PTY. LTD.

256-8 City Road, South Melbourne, Victoria 3205, Australia

© AUGST, 1974 Printed in Japan



PIONEER ELECTRONIC CORPORATION
4-1, 1-chome, Meguro, Meguro-ku, Tokyo 153, Japan

No. S-75002

SERVICE BULLETIN

Service Department, International Division

LIST OF PARTS CHANGED FOR FACTORY MODIFICATION

DATE May.12.1975

Subject: Headphone unit assemblies have been changed.

Reason: Improvement of reliability and sound quality.

Parts Number		Parts Name or Description		* Disposition of Former Parts
Former	New	Former (Remove)	New (Add)	
SXC-109	SXC-120	Headphone unit assembly (L)		C
SXC-110	SXC-121	"	(R)	C

*Disposition of former parts marked as A, B and C means;

- A: Discard.
- B: Available for other model. So, please keep it.
- C: Available only for model of before modification. So, please keep it.
- D: Available after minor improvement. So, please keep it.

Model	Application			Ref. of S. Manual	
	Unit or Ass'y No.	Serial No.	Month	Page	Position
SE-700	-	-	April '75	1,2	Key No.12,14

Notice: Please alter the service manuals in accordance with the above table.

Please turn over

Explanation:

To distinguish the difference between the old and the new one, "A" is marked on the base of headphone unit assembly as shown below.

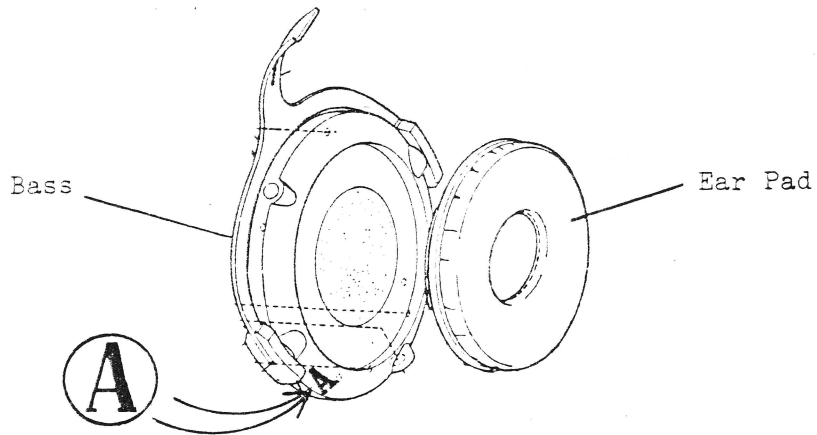

The former and new headphone unit assemblies are not interchangeable. So, Please do not use both the old and the new type together.