

# Service Manual

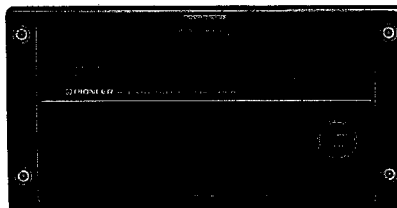

**ORDER NO.  
CRT 1136**

**MULTI-PLAY COMPACT DISC PLAYER**

# CDX-M100

**UC, EW**  
**COMPACT disc**  
DIGITAL AUDIO

## CONTENTS

|   |    |   |    |
|---|----|---|----|
| 1. SAFETY INFORMATION (CDX-M100/EW) ..... | 2  | 8. CHASSIS EXPLODED VIEW .....              | 81 |
| 2. DISASSEMBLY .....                      | 3  | 9. CD MECHANISM UNIT (1) .....              | 84 |
| 3. MECHANISM DESCRIPTION .....            | 6  | 10. CD MECHANISM UNIT (2) .....             | 88 |
| 4. CIRCUIT DESCRIPTION .....              | 8  | 11. ELECTRICAL PARTS LIST .....             | 91 |
| 5. ADJUSTMENT .....                       | 29 | 12. PACKING METHOD .....                    | 94 |
| 6. SCHEMATIC CIRCUIT DIAGRAM .....        | 66 | 13. NAME OF PARTS AND THEIR FUNCTIONS ..... | 95 |
| 7. CONNECTION DIAGRAM .....               | 74 | 14. CONNECTION .....                        | 96 |

## SPECIFICATIONS

### General

System..... Compact disc audio system  
Usable discs ..... Compact Disc  
Signal format ..... Sampling frequency: 44.1 kHz  
Number of quantization bits: 16; linear  
Power source ..... 14.4 V DC (10.8 — 15.6 V allowable)  
Power consumption ..... 5.5 W  
Maximum power consumption ..... 9 W  
Weight ..... 5.0 kg (11.0 lbs.)  
Dimensions ..... 210 (W) x 110 (H) x 330 (D) mm  
[8-1/4 (W) x 4-3/8 (H) x 13 (D) in.]

### Audio

Frequency characteristics ..... 5 — 20,000 Hz (±1 dB)  
Signal-to-noise ratio ..... 85 dB (1 kHz)(IHF-A network)  
Dynamic range ..... 87 dB (1 kHz)  
Wow and flutter ..... Below measurement range  
Distortion factor ..... 0.008% (1 kHz, 0 dB)  
Output level ..... 500 mV (1 kHz, 0 dB)  
Number of channels ..... 2 (stereo)

*These specifications were determined and are presented in accordance with specification standards established by the Ad Hoc Committee of Car Stereo Manufacturers.*

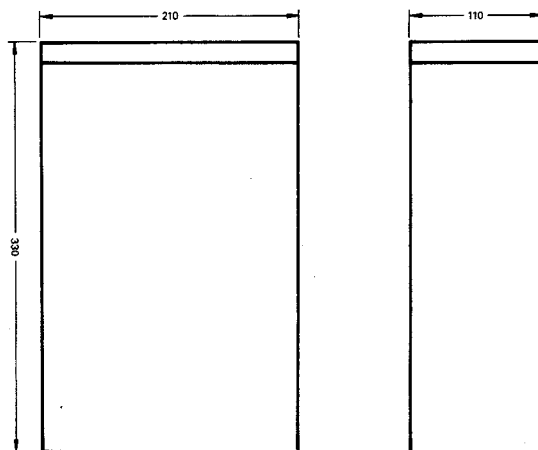

**Note:**  
Specifications and the design are subject to possible modification without notice due to improvements.

## • CD Player Service Precautions

1. Since these screws protect the mechanism during transport, be sure to affix it when it is transported for repair, etc.
2. For pickup unit (CGY1006) handling, please refer to "Disassembly" (Fig. 6). During replacement, handling precautions shall be taken to prevent an electrostatic discharge (protection by a short pin).
3. During disassembly, be sure to turn the power off since an internal IC might be destroyed when a connector is plugged or unplugged.

## Removal of Screws

Be sure to remove transportation screws (red) ①, ② and ③ in this order.

## Reinstallation of Screws

Be sure to reinstall the transportation screws (red) in the procedure described below before re-transporting the set. Incorrect order of reinstallation or use of different screws may cause the set to fail.

1. Let the set operate the first music of a disc and stop operation within 10 seconds thereafter before removing the set.
2. Remove the magazine and then the set.
3. Reinstall the transportation screws in the reverse order ③, ② and ① of removal.

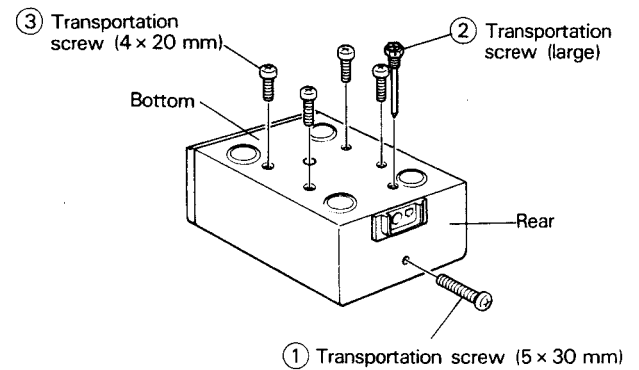

Fig. 1

## • Location of Major Parts

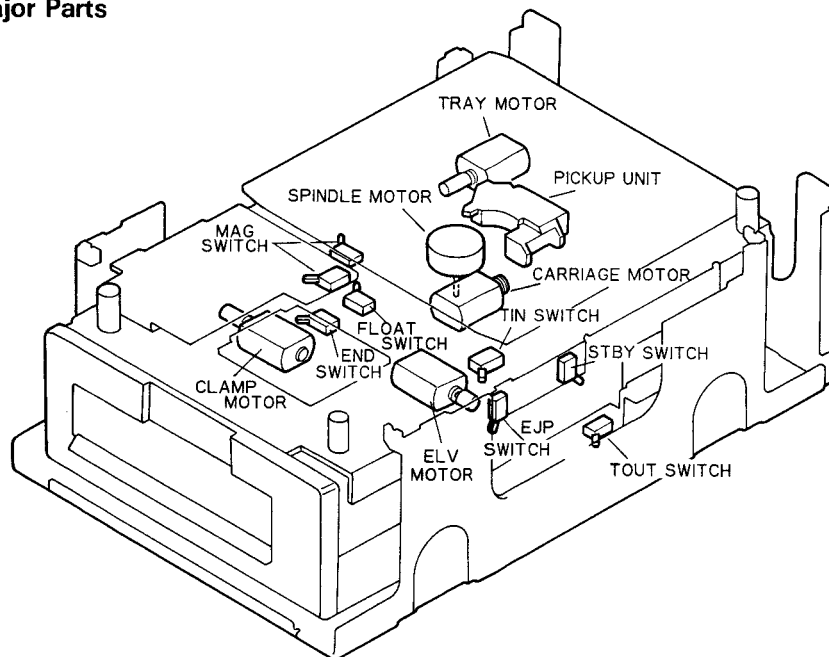

Fig. 2

# 1. SAFETY INFORMATION (CDX-M100/EW)

## 1. Safety Precautions for those who Service this Unit.

- Follow the adjustment steps (see pages 29 through 50) in the service manual when servicing this unit. When checking or adjusting the emitting power of the laser diode exercise caution in order to get safe, reliable results.

### Caution:

1. During repair or tests, minimum distance of 13cm from the focus lens must be kept.
2. During repair or tests, do not view laser beam for 10 seconds or longer.

2. A "CLASS 1 LASER PRODUCT" label is affixed to the bottom of the player.

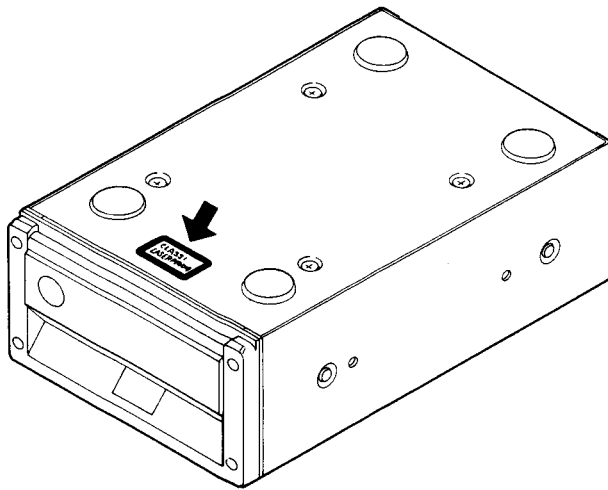

3. The triangular label is attached to the mechanism unit plate unit.

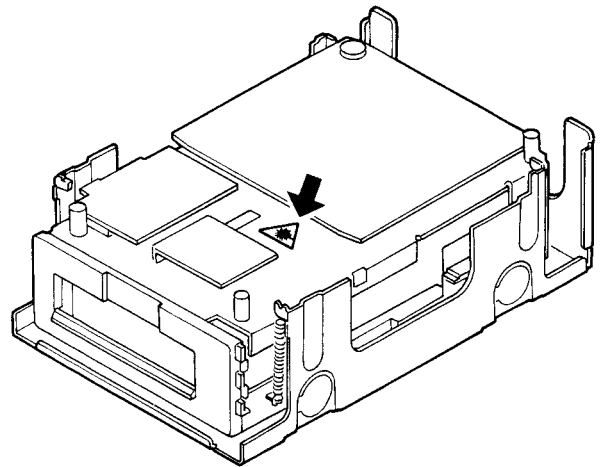

## 4. Specifications of Laser Diode

Specifications of laser radiation fields to which human access is possible during service.

- Wavelength = 780 nanometers
- Radiant power = 69.7 microwatts  
(Through a circular aperture stop having a diameter of 80 millimeters)
- 0.55 microwatts  
(Through a circular aperture stop having a diameter of 7 millimeters)

## 2. DISASSEMBLY

### • Case

Unfasten the four screws to remove the case.

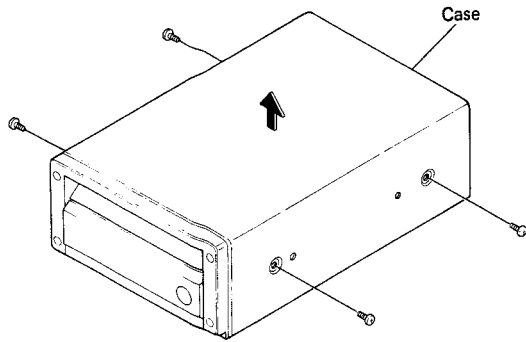

Fig. 3

### • CD Mechanism Unit

1. Unfasten the four screws.
2. Disconnect the two connectors.
3. To avoid catching the part A screws, lift the unit up while pulling forward a little.

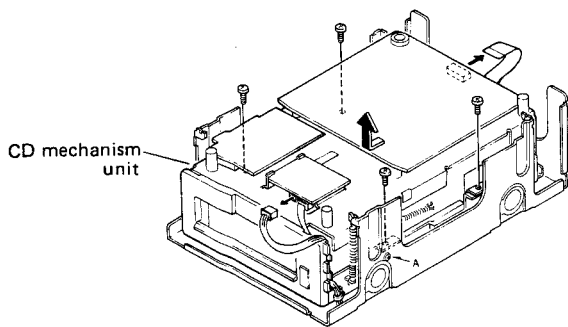

Fig. 4

### • Damper Units

Unfasten the collars and screws to remove the damper units.

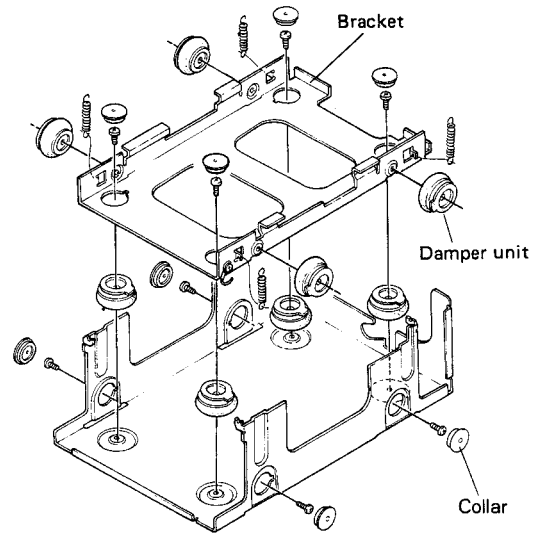

Fig. 5

### • Main Unit

1. Unfasten the five screws.
  2. Disconnect the four connectors to remove the main unit.
- Note: When removing the flexible P.C. board, always insert a shorting pin or insert an inter-pattern short (jumper) before disconnecting the board from the connector.

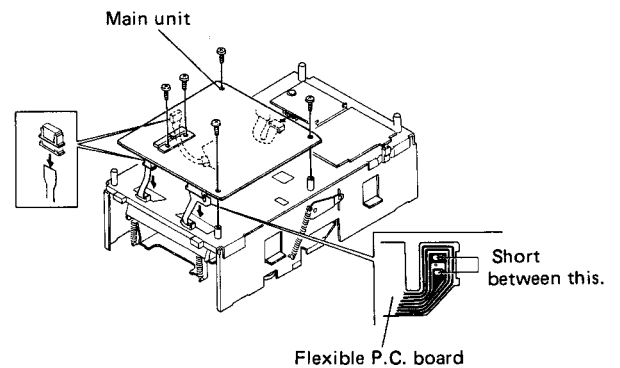

Fig. 6

• **Tray Motor Unit**

Unfasten the four screws to remove the tray motor unit.

• **Clamper Arm Unit**

1. Remove the E-shaped retaining ring and two springs to remove the clamper arm unit.

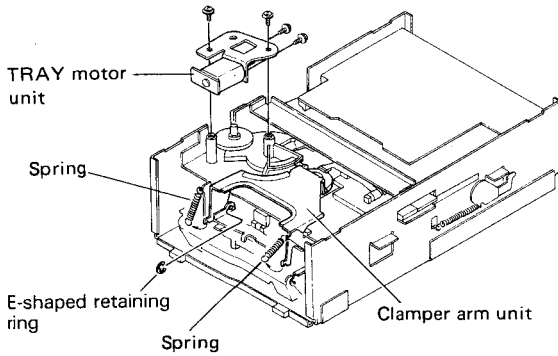

Fig. 7

• **Carriage Mechanism Unit**

1. Unfasten the five screws marked A to remove the sub-chassis unit.

2. Then unfasten the four screws marked B to remove the carriage mechanism ass'y.

Note: When remounting the carriage mechanism ass'y, check that pin is accounted for as shown in the diagram.

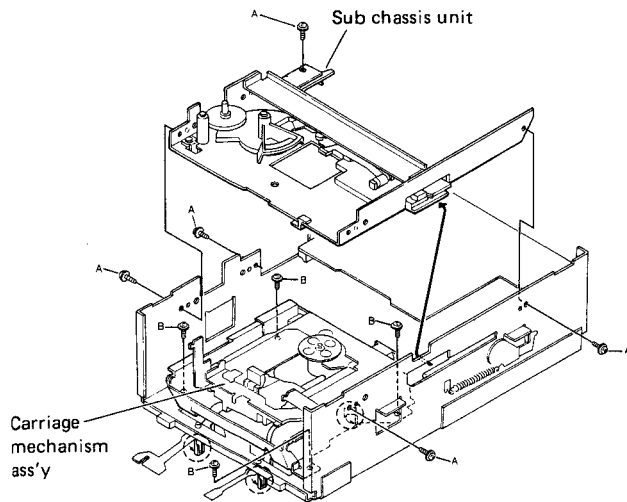

Fig. 8-1

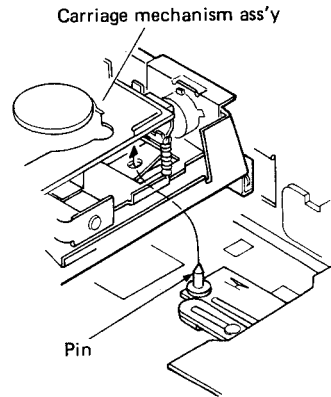
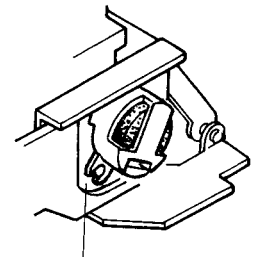
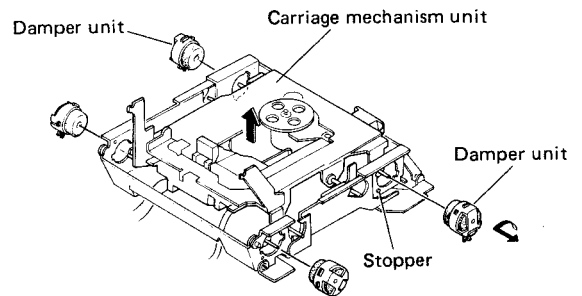

Fig. 8-2

3. Turn the damper units, and remove by aligning the groove.  
4. Remove the carriage mechanism unit.



When remounting, align this part with the stopper after reinserting the damper unit.

Fig. 9

**• Magazine Holder**

1. Position the magazine holder at the top (by turning the elevation gear).
2. Remove the two springs, three E-shaped retaining rings, and two rollers. (The rollers are stopped with the smaller diameter roller on the inside.)
3. Unfasten the three screws and the side frame unit.  
Note: When remounting the side frame unit, make sure that the arm unit pin is as indicated in the diagram.
4. Remove the magazine holder.

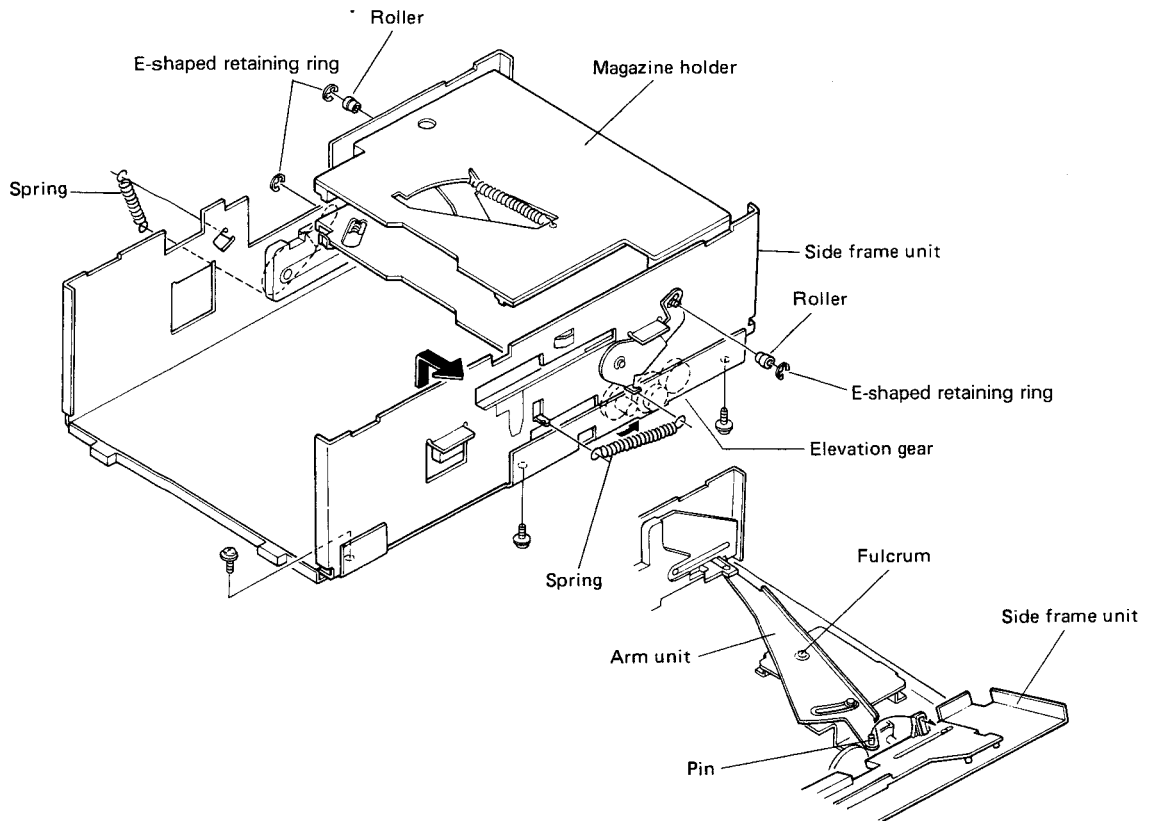

Fig. 10

### 3. MECHANISM DESCRIPTION

• **Magazine Insertion and Disc Detection**

1. When the magazine is inserted, the MAG-1 switch (magazine sensor) is switched ON by a lever.
2. The MAG-2 switch is switched ON (magazine lock hole is sensed) and the magazine is locked by the same lock arm action.

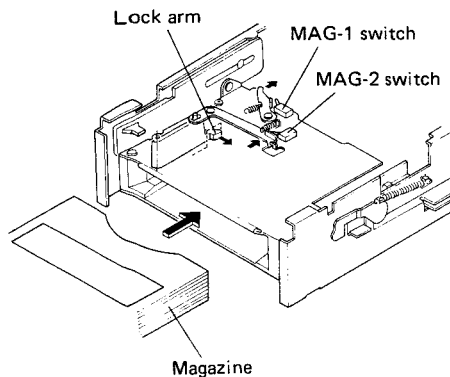

Fig. 11

3. The ELV (elevation) motor is started when both the MAG-1 and MAG-2 switches are switched ON. As a result, the left and right side frame unit stairs are activated.
4. After an initial stair movement which switches the EJP switch ON (reset action), the stairs move back. The magazine position sensor hole is detected by a photo-interrupter, and the ELV motor stops when the first hole (for tray 6) is reached.
5. The magazine holder is raised and lowered along magazine holder guide grooves in the left and right side frame units.

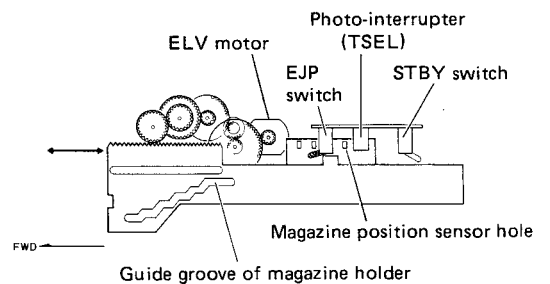

Fig. 12

6. The tray motor is started and the gears begin to turn. Lever (1) is pushed in the direction of the arrow by gear action, and lever (2) is shifted by spring (1) (the spring which keeps the tray against the stopper when a tray is ejected).
7. Lever (2) turns the arm in the direction of the arrow. The magazine trays are pushed out by this arm.

8. The tray motor is reversed and the tray housed as soon as a disc is detected by the disc sensor photo-interrupter (disc presence detection). The tray motor is stopped when the TOUT switch is switched ON.
9. Likewise, the presence of a disc is detected by steps 6 thru 1.

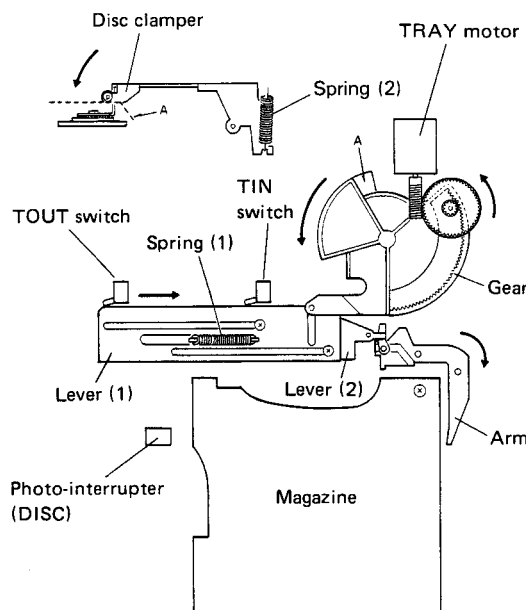

Fig. 13

• **Disc Playback Operation**

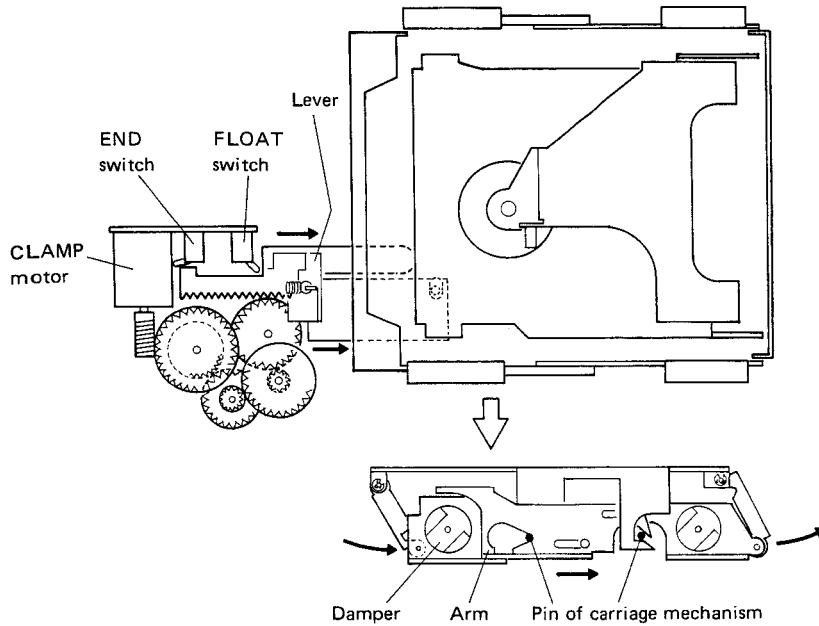

Fig. 14

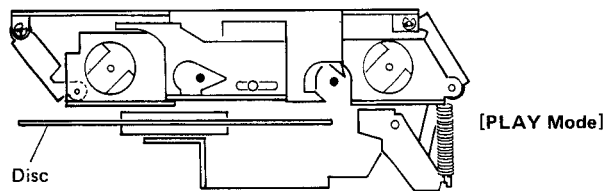

Fig. 15

1. A tray is ejected by tray motor action in the same way as during disc detection.
2. As soon as the TIN switch is switched OFF, the tray motor is stopped and the tray is held in position.
3. The disc clamber is fixed by gear, but is released when the disc clamber pin reaches section A while the gear is turning. After the disc clamber is released, the disc is held in position by spring (2).
4. The carriage mechanism is locked with the pin caught by the arm.
5. The lever is moved in the direction of the arrow by clamp motor rotation.
6. The carriage mechanism is unlocked by the lever pressing against the arm to enable disc playback (with the mechanism in a "floated" state).
7. The clamp motor ON/OFF timing is controlled by the FLOAT and END switches.



## 4. CIRCUIT DESCRIPTION

### 1. Preamplifier Stage

The preamplifier stage processes the pick-up output signal, and generates signals for the following servo, demodulator, and control stages. The signal from the pick-up undergoes I-V conversion in the preamplifier IC901 (with built-in photo-detector), and is then processed in the RF amplifier (IC351) to generate RF, FE, and TE signals.

This stage consists of the single-chip IC CXA1081M divided into a number of component sections. Because of the single power line (+5V) specifications of this system, the signal reference voltage VC is 2.5V. All subsequent voltages are expressed in the "VC" unit. (The unit of voltage when the reference voltage is 0V is "V".)

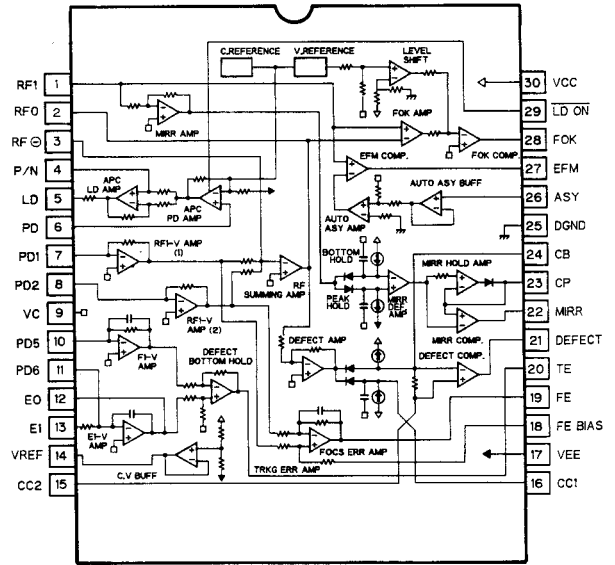
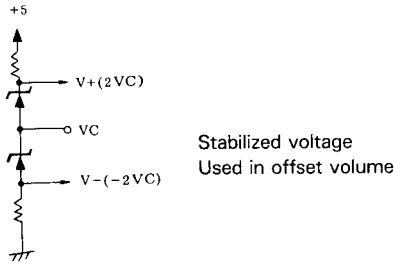

Fig. 16 Block diagram

The internal configuration of this 30-pin flat package IC is shown in Figure 16.

The major component sections are outlined below.

#### (1) RF amplifier

The photo-detector outputs A, B, C, and D are added in amplifiers (1) and (2) to generate the (B + D) and (A + C) RF signals. The outputs are also added in the RF summing amplifier with the resultant output (A + B + C + D) being passed to RFO. (The eye pattern check can be executed at this pin.)

The low frequency components in the RFO output voltage VRFO are:-

$$VRFO = - [(R354 + R378)/10k\Omega] \times (VA + VB)$$

$$VA = - [58k\Omega/R358] \times (VA' + VC')$$

$$VB = - [58k\Omega/R356] \times (VB' + VD')$$

Both R378 and R354 are 22 kΩ in this case.

An RF (DC) output with a peak value of 1.6[VC] and a bottom of about 0.4[VC] when DC, and VRFO = 1.2Vp-p when AC is obtained at the RFO output (pin 2).

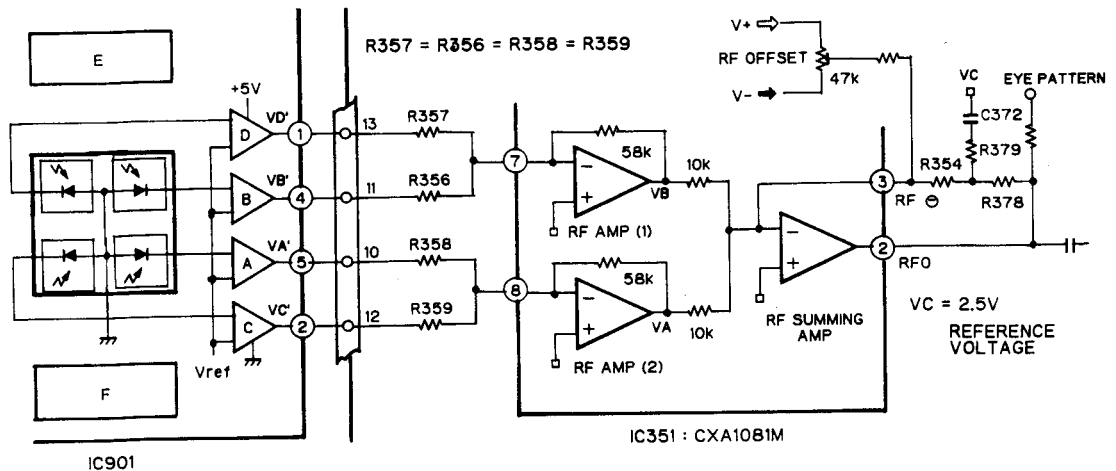

Fig. 17 Block diagram

(2) Focus error amplifier

The difference between the RF amplifier (1) output VB and the RF amplifier (2) output VA is taken to obtain the A + C - B - D signal.

The FE output voltage (low frequency) is

$$V_{FE} = 5.4 \times (VA - VB)$$

When the combined impedance to ground is about 10 kΩ (VR resistance about 40 kΩ), the external VR connected to pin 18 is set to maximum common mode rejection.

The FE output (pin 19) attains a voltage of about 2[Vp-p] describing an S-curve.

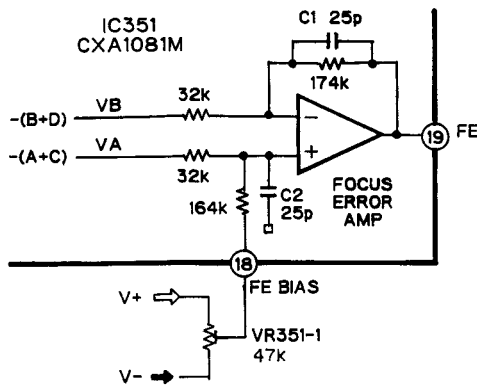

Fig. 18 Focus error amp circuit

(3) Tracking error amplifier

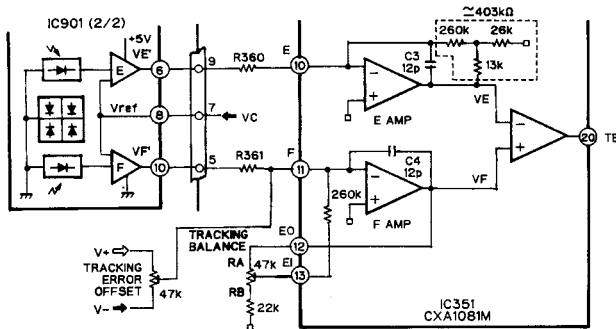

Fig. 19 Tracking error amp circuit

The side-spot PIN diode voltage applied to E and F is amplified by the respective E and F amplifiers. That is,

$$VE = -(403 \text{ k}\Omega / R360) \times VE'$$

$$VF = -[260 \text{ k}\Omega \times RA / (RB + 22 \text{ k}\Omega) + (RA + 260 \text{ k}\Omega)] / R361 \times VF'$$

The E and F amplifier difference is obtained by the tracking error amplifier to generate the (E-F) output. The tracking error amplifier gain at 3.2 (10.1dB) is

$$VTE = (VF' - VE') \times 403 \text{ k}\Omega / R360 \times 3.2$$

C3 and C4 are necessary to prevent leakage of EFM components to the tracking error output.

The T·E offset VR cancels DC offset from the preamplifier up to the servo amplifier, and the tracking error signal symmetry is adjusted by the TRKG balance VR. These conditions are mainly required to ensure normal track jumping. The tracking error of about 1 [Vp-p] is obtained as the pin 20 output.

(4) Focus OK circuit

The focus OK circuit generates the timing window for switching the focus servo ON when in focus search status.

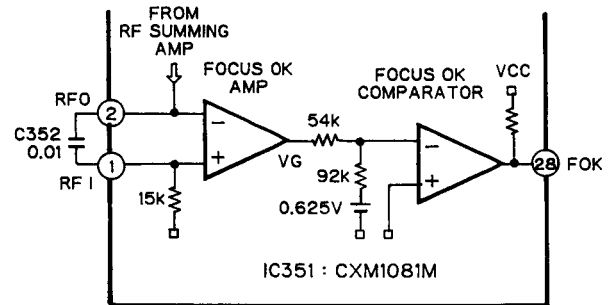

Fig. 20 Focus OK circuit

The high-pass filter output for the RF signal from pin no. 2 is obtained from pin no. 1, thereby providing the phase of the low-pass filter output (opposite phase) of the focus OK amplifier output.

The focus OK output is inverted when  $V_{RFI} - V_{RFO} \cong -0.39V$ .

C352 determines the time constants for the EFM comparator, the mirror circuit high-pass filter, and the focus OK amplifier low-pass filter. This can help prevent deterioration in the block error rate caused by RF envelope loss in scratched discs.

The optimum C352 value in this system is 0.01 [μF]. In this case,  $f_c = 1\text{kHz}$ .

(5) Mirror circuit

RFI signal amplification is followed by peak and bottom holding. Peaks are held by a time constant which enables the peak hold status to follow a 30 kHz traverse, and bottom levels are held by a time constant which enables the bottom hold status to follow deviations in the rotating cycle envelope.

The DC playback envelope signal (J) is obtained by differen-

tial amplification of the peak and bottom hold signals (H) and (I). The mirror output is obtained by comparing this (J) signal with signal (K) obtained by peak holding (using a large time constant) a level equal to 2/3 the peak value. That is, the mirror output is "L" when on a disc track, "H" when between tracks (mirror portion), and also "H" when a defect is detected. The mirror hold time constant needs to be sufficiently larger than the traverse signal.

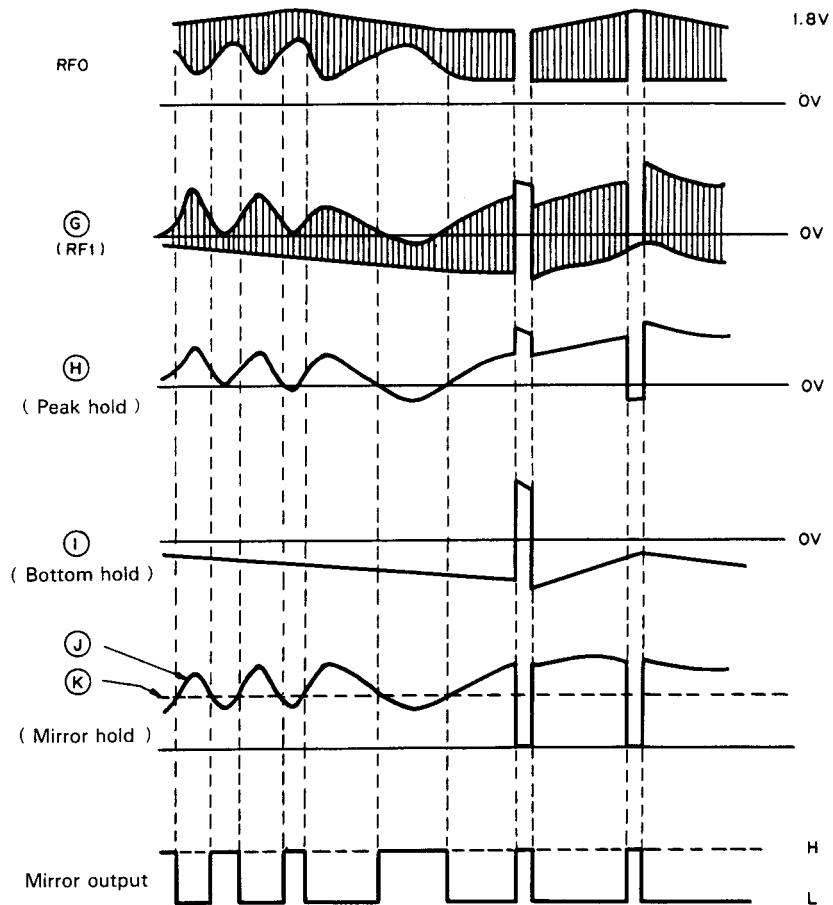
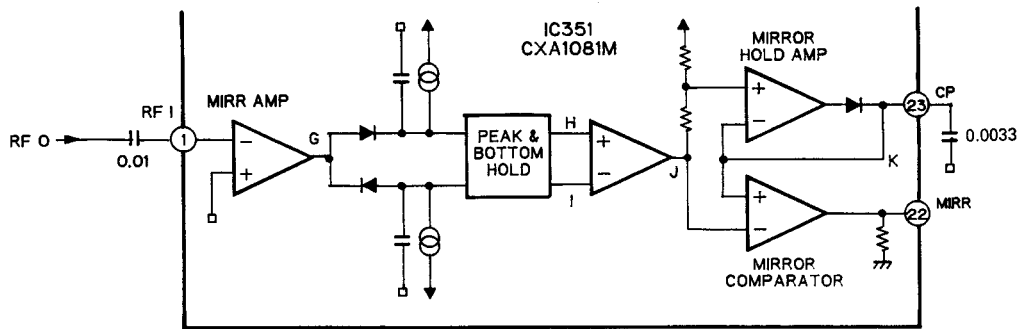

Fig. 21 Mirror circuit



(6) EFM comparator

The EFM comparator splits the RF signal into a bi-value signal. Since the asymmetry resulting from variations in disc manufacture cannot be eliminated only by AC coupling, the fact that 1,0 offered probability in the bi-value EFM signal is 50% each is used to control EFM comparator reference voltage.

Since the EFM comparator is a current switch type, the "H" and "L" levels are not the same as the power supply voltage.

age. Therefore, feedback must be applied via a CMOS buffer.

R367, R715, C359, and C724 form a low-pass filter used to obtain +2.5V DC. leakage of the EFM low region components becomes serious if  $f_c = 500\text{Hz}$  is exceeded, resulting in deterioration of the block error rate.

This system is divided into two stages with  $f_c = 3.4[\text{Hz}]$  at C359 =  $0.47\mu\text{F}$  and R367 =  $100\text{ k}\Omega$ , and  $f_c = 1.6[\text{kHz}]$  at C724 =  $0.01\mu\text{F}$  and R715 =  $10\text{ k}\Omega$ .

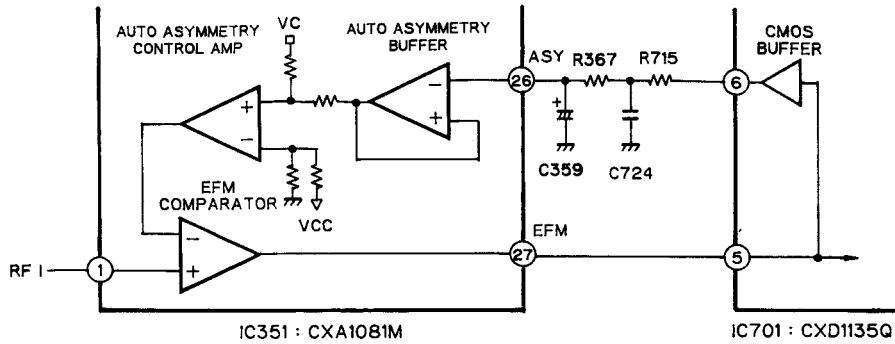

Fig. 22 EFM comparator circuit

(7) Automatic power control (APC) circuit

When laser diodes are driven by constant current, the optical output exhibits large negative thermal characteristics. The monitor photodiode output, therefore, must be controlled to maintain the current at a constant level. This control is handled by the APC circuit. LDI is about 40mA in this system.

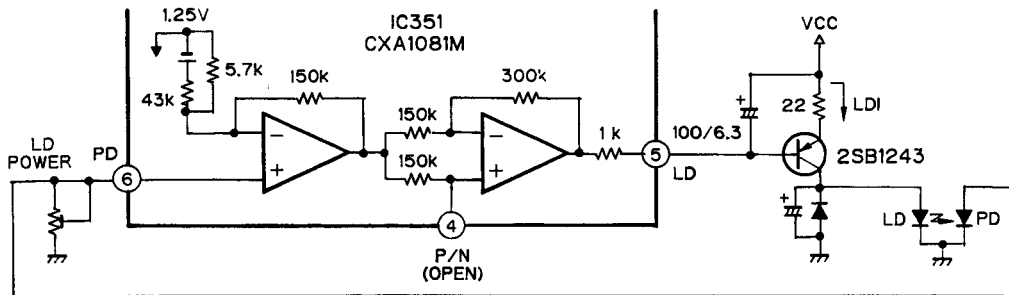

Fig. 23 APC circuit

(8) Defect circuit

RFI signal inversion is followed by bottom holding with two different time constants - one small and the other large. The small time constant bottom holding is in response to defects in excess of 0.1 msec in the disc's mirror, and the large time constant bottom holding holds the mirror level preceding the

defect. Comparing the two signals by C-coupling differentiation plus level shifting results in the generation of a mirror defect detector signal (defect signal). In this system, the defect signal is used to generate an "H" output (when a defect is detected), and switch the tracking and focus servos OFF, and thereby improve the playability.

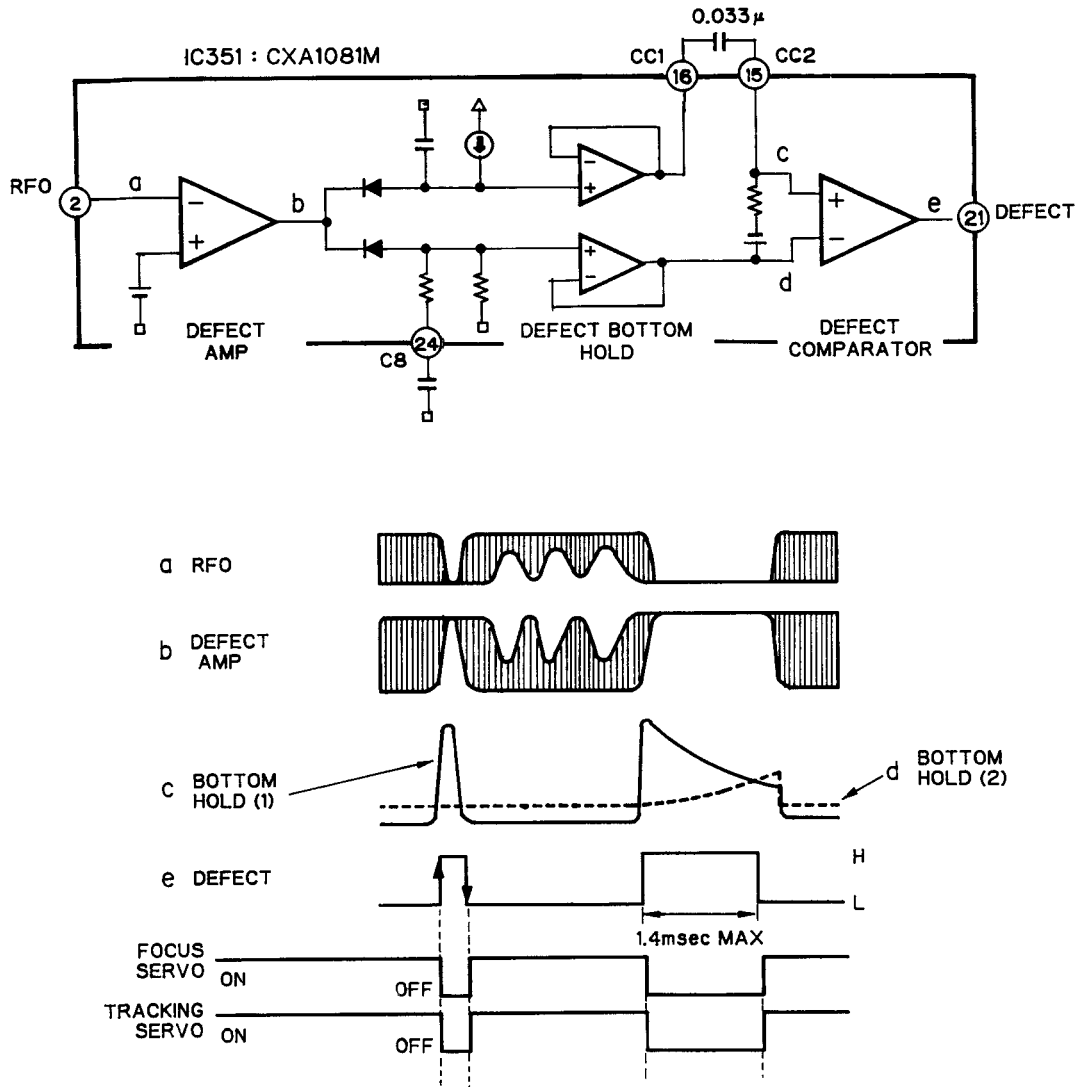

Fig. 24 Defect circuit

**2. Servo Stage**

This stage covers focus, tracking, carriage, and spindle servo operations, plus in-focus and track-jump servo control by executing commands from the system microcomputer. This block diagram centered about this 48-pin flat package IC (CXA1082AQ) is shown in Figure 25. This IC incorporates an auto sequencer for execution of track jumping by transfer of serial data from the system microcomputer. The major components are outlined below.

**(1) Command Code**

CXA1082AQ and the demodulator IC CXD1135Q are controlled by serial data from the system microcomputer. Various detector outputs are obtained from the SENS pin. The serial data, CLK, and command execution XLT timing chart is shown in Figure 26.

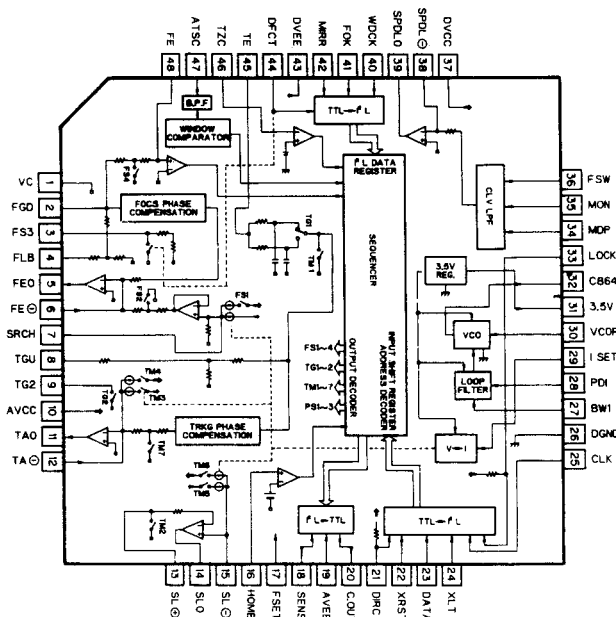

Fig. 25 CXA1082AQ Block diagram

Table 1 Operation mode and data of the CXA1082AQ

System control

| Parameter        | ADDRESS                  |    |    |    | DATA             |          |              |        | SENS OUT |
|------------------|--------------------------|----|----|----|------------------|----------|--------------|--------|----------|
|                  | D7                       | D6 | D5 | D4 | D3               | D2       | D1           | D0     |          |
| Focus Control    | 0                        | 0  | 0  | 0  | FS4              | FS3      | FS2          | FS1    | FZC      |
|                  |                          |    |    |    | Focus            | Gain     | Search       | Search |          |
|                  |                          |    |    |    | ON               | Down     | ON           | Up     |          |
| Tracking Control | 0                        | 0  | 0  | 1  | Anti             | Brake    | TG2          | TG1    | A.S      |
|                  |                          |    |    |    | Shock            | ON       | Gain Set     |        |          |
| Tracking Mode    | 0                        | 0  | 1  | 0  | Tracking Mode *1 |          | Sled Mode *2 |        | TZC      |
| Select           | 0                        | 0  | 1  | 1  | PS4              | PS3      | PS2          | PS1    | SSTOP    |
|                  |                          |    |    |    | Focus            | Focus    | Sled         | Sled   |          |
|                  |                          |    |    |    | Search+2         | Search+1 | Kick+2       | Kick+1 |          |
| Auto Sequence    | 0                        | 1  | 0  | 0  | AS3              | AS2      | AS1          | AS0    | BUSY     |
| RAM SET          | Blind (A.E)/Overflow (C) |    |    |    | 0                | 1        | 0            | 1      | Hi-Z     |
|                  | Brake (B)                |    |    |    | 0                | 36       | 18           | 9      |          |
|                  | Kick (D)                 |    |    |    | 0                | 116      | 58           | 29     |          |
|                  | Track Jump (N)           |    |    |    | 0                | 64       | 32           | 16     |          |
|                  | Track Move (M)           |    |    |    | 0                | 128      | 64           | 32     |          |

\*1 TRACKING MODE

|          | D3 | D2 |
|----------|----|----|
| OFF      | 0  | 0  |
| ON       | 0  | 1  |
| FWD JUMP | 1  | 0  |
| REV JUMP | 1  | 1  |

\*2 SLED MODE

|          | D1 | D0 |
|----------|----|----|
| OFF      | 0  | 0  |
| ON       | 0  | 1  |
| FWD MOVE | 1  | 0  |
| REV MOVE | 1  | 1  |

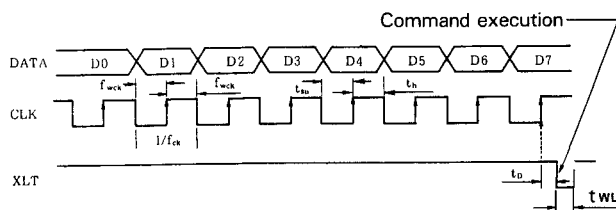

Fig. 26 CPU serial interface timing chart

| Parameter         | Symbol    | Minimum value | Typical value | Maximum value | Unit |
|-------------------|-----------|---------------|---------------|---------------|------|
| Clock frequency   | $f_{ck}$  |               |               | 1             | MHz  |
| Clock pulse width | $f_{wck}$ | 500           |               |               | ns   |
| Set-up time       | $t_{su}$  | 500           |               |               | ns   |
| Hold time         | $t_h$     | 500           |               |               | ns   |
| Delay time        | $t_D$     | 500           |               |               | ns   |
| Latch pulse width | $t_{wL}$  | 1000          |               |               | ns   |

DV<sub>cc</sub> - DGND = 4.5 ~ 5.5V

a) Commands

The 8-bit input data used to drive this IC is expressed below as 2-digit hexadecimal values in the \$XX format (where X is a value from 0 to F).

There are eight main types of commands used in CXA1082AQ. These are numbered \$0X thru \$7X.

1. \$0X (SENSE pin ⑱ "FZC")

Focus servo control command  
Bit configuration:

|    |    |    |    |     |     |     |     |
|----|----|----|----|-----|-----|-----|-----|
| D7 | D6 | D5 | D4 | D3  | D2  | D1  | D0  |
| 0  | 0  | 0  | 0  | FS4 | FS3 | FS2 | FS1 |

The four switches FS1 thru FS4 related to focussing correspond to D0 thru D3.

2. \$1X (SENSE pin ⑱ "AS")

This command is related to TG1, TG2, and brake circuit ON/OFF.

|    |    |    |    |                   |                      |     |     |
|----|----|----|----|-------------------|----------------------|-----|-----|
| D7 | D6 | D5 | D4 | D3                | D2                   | D1  | D0  |
| 0  | 0  | 0  | 1  | ANTI SHOCK ON/OFF | Brake circuit ON/OFF | TG2 | TG1 |

3. \$2X (SENSE pin ⑱ "TZC")

This command is involved in tracking servo and sled servo ON/OFF, and generation of jump and fast forward pulses during access.

|    |    |    |    |                  |                |    |    |
|----|----|----|----|------------------|----------------|----|----|
| D7 | D6 | D5 | D4 | D3               | D2             | D1 | D0 |
| 0  | 0  | 1  | 0  | Tracking control | Sled control   |    |    |
|    |    |    |    | 00 off           | 00 off         |    |    |
|    |    |    |    | 01 Servo ON      | 01 Servo ON    |    |    |
|    |    |    |    | 10 F-JUMP        | 10 R-fast feed |    |    |
|    |    |    |    | 11 R-JUMP        | 11 F-fast feed |    |    |
|    |    |    |    | TM1, TM3 ,       | TM2, TM5 ,     |    |    |
|    |    |    |    | TM4              | TM6            |    |    |

The SENSE pin (pin 18)

The SENSE pin output differs according to the input data.

- FZC when \$0X,
- AS when \$1X,
- TZC when \$2X,
- SSTOP when \$3X,
- BUSY when \$4X,
- HIGH-Z when \$5X thru \$7X

Since \$7X and above are CXD1135 command codes, connection to the CXD1135 SENS pin enables a number of different outputs to be obtained from the one pin.

Since tracking jumps are executed by the auto sequencer, the \$4X BUSY output is the only CXA1082AQ output used by the system microcomputer.

(2) Focus Servo System

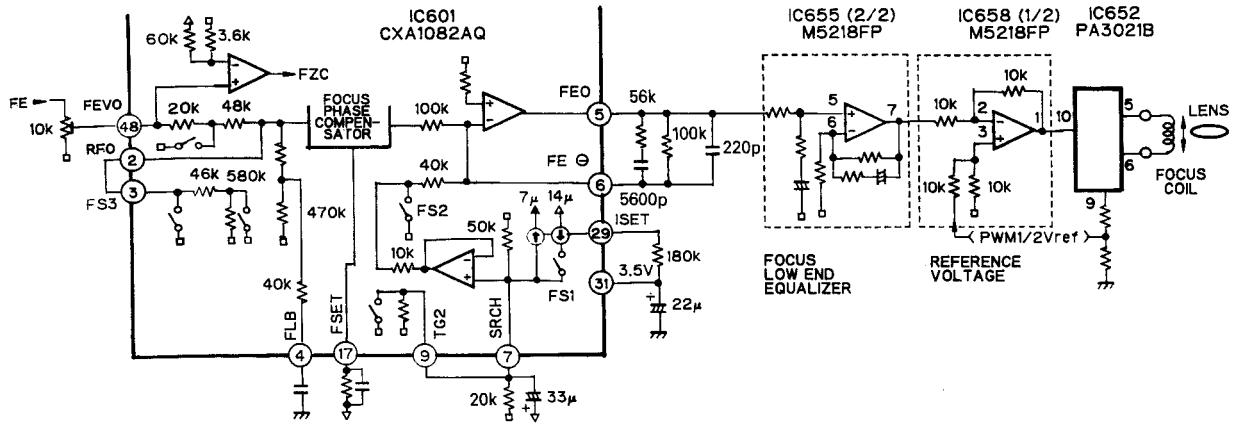

Fig. 27 Focus servo system block diagram

The above diagram is a block diagram of the focus servo system. The capacitor connected to pin 4 is the time constant designed to boost the low end during normal playback. The built-in constant current (ISET current) is determined by the resistance connected across pins 29 and 31, the current being  $7\mu\text{A}$  at  $180\text{ k}\Omega$ .

$$\text{ISET current} = 1.27\text{V}/\text{R}$$

This current is used in focus search, tracking jump, and carriage kick operations. The FZC comparator inverted input reference voltage is set to  $(\text{VCC}-\text{VC}) \times 5.7\%$  (Approx.  $140\text{mV}$ )

a) In-focus (search voltage)

The in-focus sequence drives the lens within the focus S curve (approximately  $10\mu\text{m}$ ) and closes the servo loop when focussed. The search voltage is determined by the focus actuator sensitivity, this being set to ensure lens driving distance of  $\pm 1\text{mm}$ . The pin 7 voltage is

$$-7[\mu\text{A}] \times 14.3(\text{k}\Omega) \times 0.63 = -0.063[\text{VC}] : \text{Lens up when FS1 is OFF, and}$$

$$(14-7)[\mu\text{A}] \times 14.3(\text{k}\Omega) \times 0.63 = +0.063[\text{VC}] : \text{Lens down when FS1 is ON.}$$

$$(14.3\text{ k}\Omega = 50\text{ k}\Omega // 20\text{k}\Omega)$$

Hence, the lens is moved up and down by switching FS1 ON and OFF. (The up/down time constants are determined by the resistance and capacitance connected to pin 7.)

Note that in-focus does not use the auto sequencer. Execution is in accordance with the timing chart (see Figure 28). The reason for this is the focus close command is issued only during lens up operation in order to prevent in-focus malfunction.

\* The expression "lens up" signifies that the lens comes closer to the disc surface.



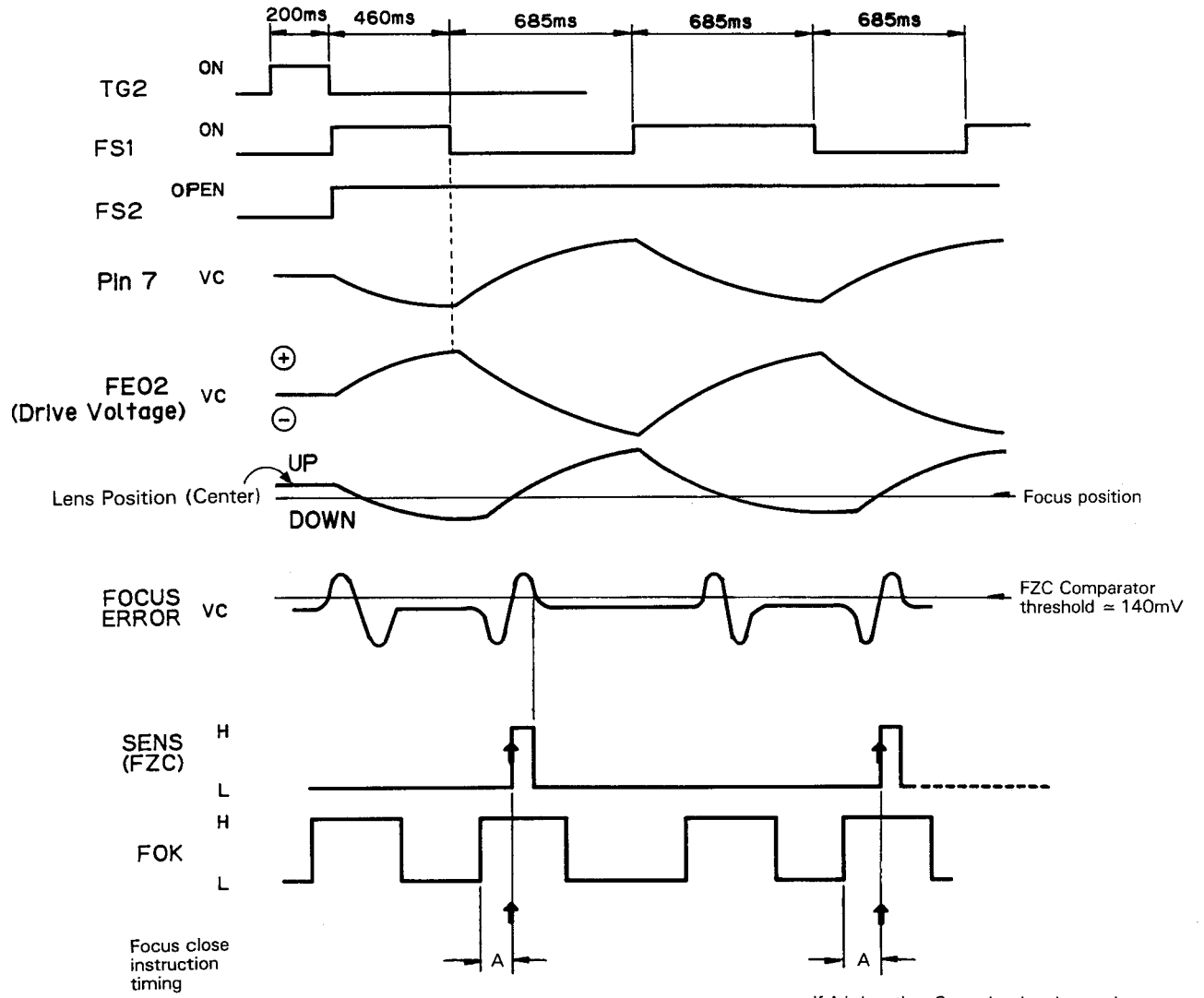

If A is less than 3 ms, the close instruction may not be issued. If this occurs, try again. A maximum of three tries are permitted.

Fig. 28 Focus close timing chart

# CDX-M100

b) Focus equalizer  
The CXA1082AQ IC incorporates a phase compensator (high end). The external compensator includes a band compensator equalizer in the FEO amplifier and a high f0 actuator compensator equalizer connected in series to obtain the required equalizer curve (see Figure 29).

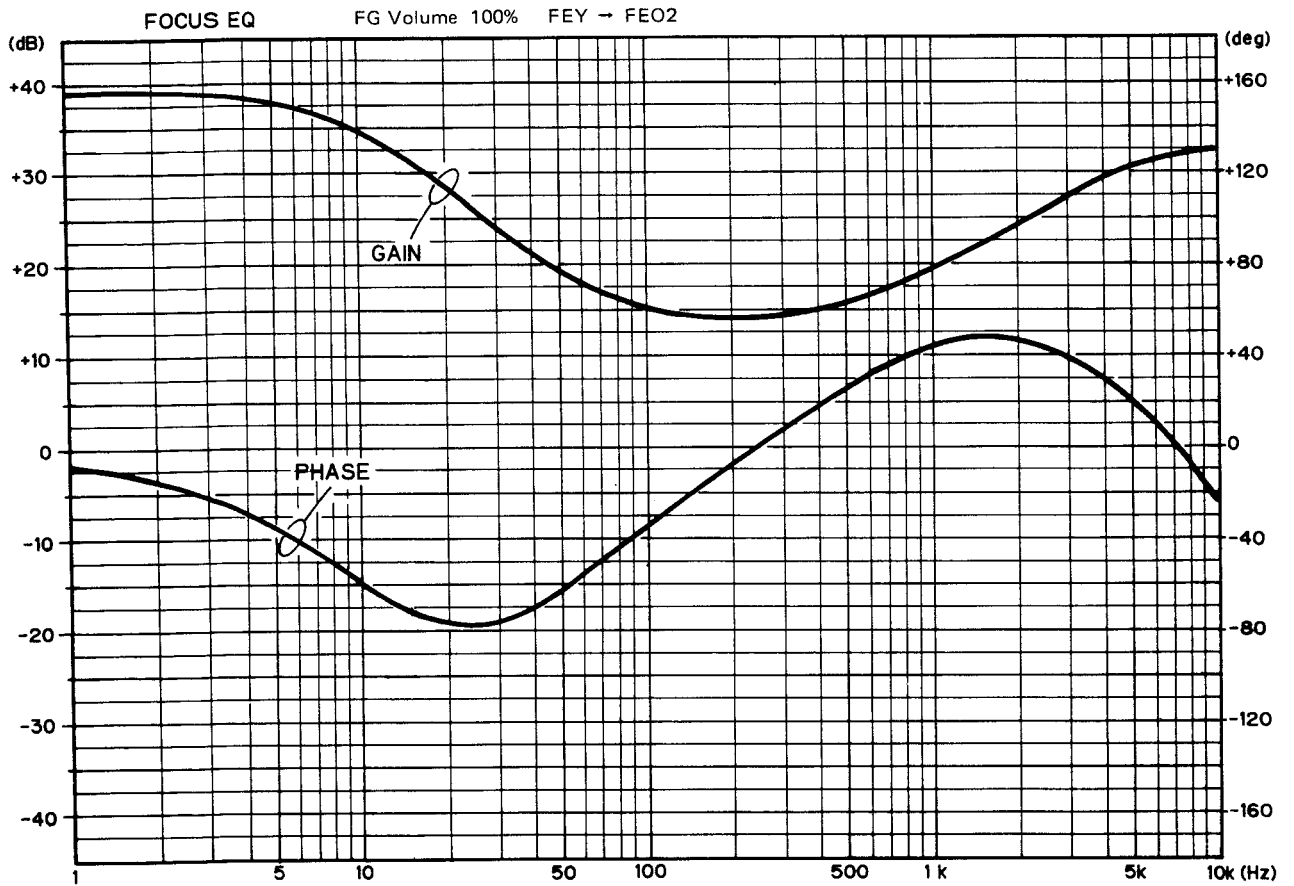

Fig. 29 Focus equalizer

17

(3) Tracking and Carriage Servos

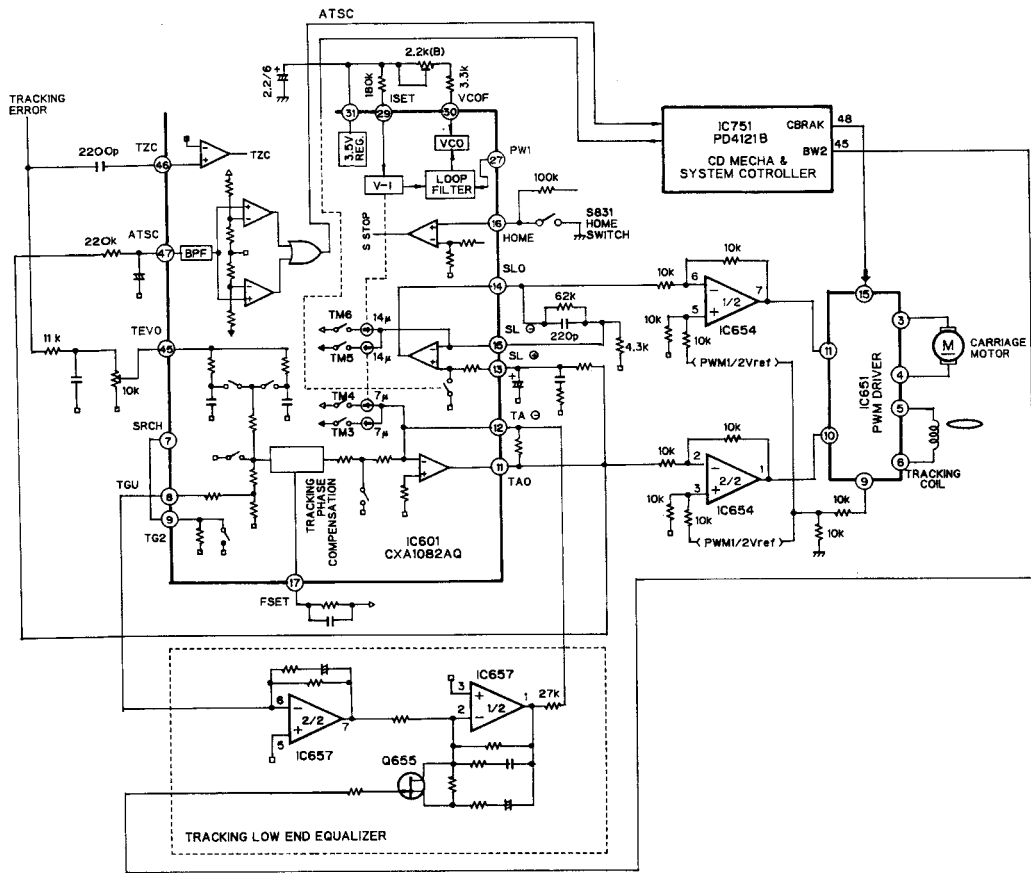

Fig. 30 Tracking, carriage servo system block diagram

The above diagram is a block diagram of the tracking and carriage servo system. At the same time that TM1 is switched ON to activate a forward or reverse tracking jump, TM3 and TM4 are switched ON and OFF. The voltage generated at pin 13 (TAO) is determined by the current passed through TM3 and TM4, and the pin 12 feedback resistance. That is,  
 Track jump peak voltage (TAO) =  $ISET_i$  (tracking)  $\times R_{TAO}$   
 $= 7[\mu A] \times 82[k\Omega] = 0.57[VC]$   
 And at the same time that TM2 is switched ON to activate a forward or reverse carriage kick, TM5 and TM6 are switched ON and OFF. The voltage generated at pin 14 (SLO) is determined by the current passed through TM5 and TM6, and the pin 15 feedback resistance. That is,  
 Carriage kick voltage (SLO) =  $ISET_i$  (carriage)  $\times R_{SLO}$   
 $= 14[\mu A] \times 62[k\Omega] = 0.87[VC]$   
 The polarity of pin 11 (TAO) is opposite to that of pin 45 (TEVO).

a) Tracking equalizer

This equalizer consists of a built-in phase compensator (high end) and a two-stage external low-end compensator connected in parallel with the former used as the main path and the latter as the side path. These signals are added at the TAO amplifier (pin 12) to obtain the required equalizer characteristics. Gain switching during playback and track searching is executed in the second side path stage. The BW2 switching signal is "H" during playback and "L" during track searches. ("H" is set to about 2.8V to ensure that Q655 is turned ON.) Hence, gain is increased during track search to attain stable action. The tracking equalizer characteristics during playback and track search are shown in Figure 31.



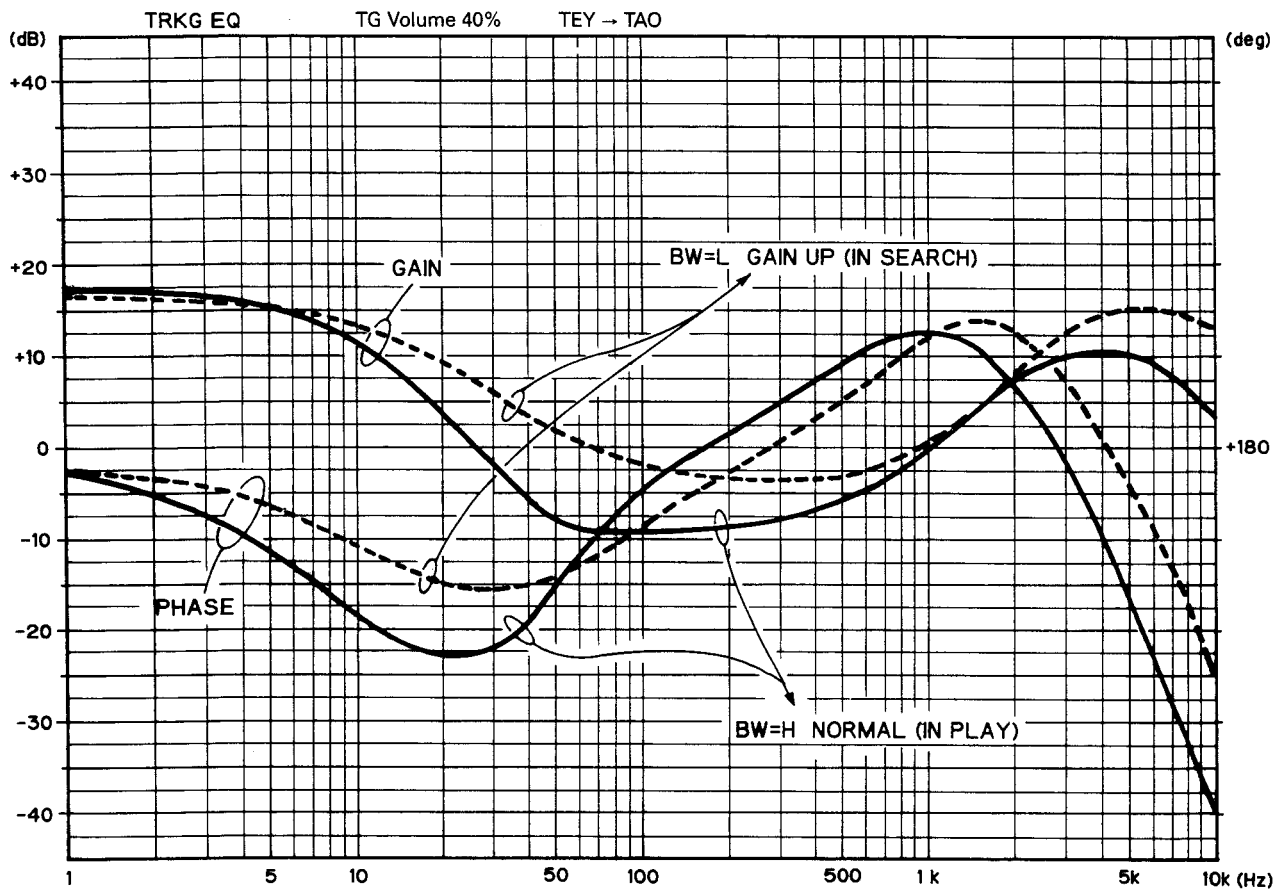

Fig. 31 Tracking equalizer

b) Brake mode circuit

Brake mode is used to execute tracking closure smoothly while the pick-up and disc are moving relatively to each other. The pick-up and disc directions are detected by the phase relationship between the envelope and tracking error at the RF, followed by switching which disengages the tracking error accelerating side so that only the decelerat-

ing side is used. This action is called brake mode, and can be controlled externally.

Brake mode is used when tracking is closed after focus-in is completed (and also when getting ON-track after a jump or track search). Hence, tracks which suffer from relatively large deviations due to eccentricity and other factors can be closed smoothly.

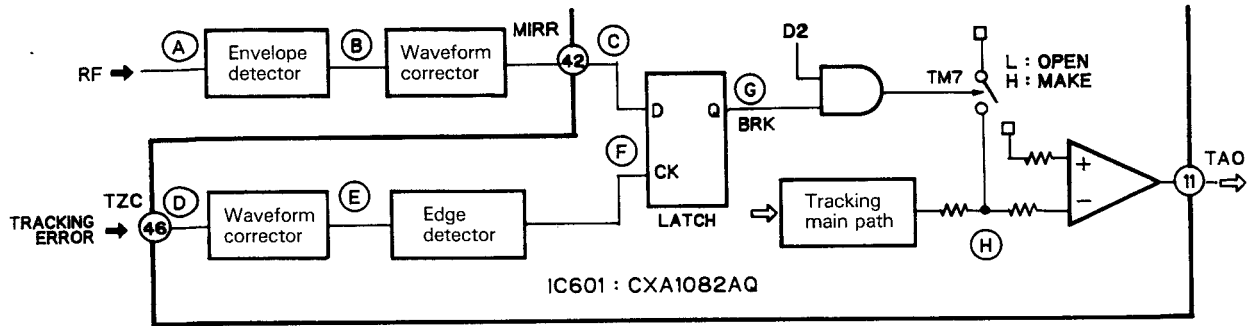

Operation of TM7 (brake circuit)

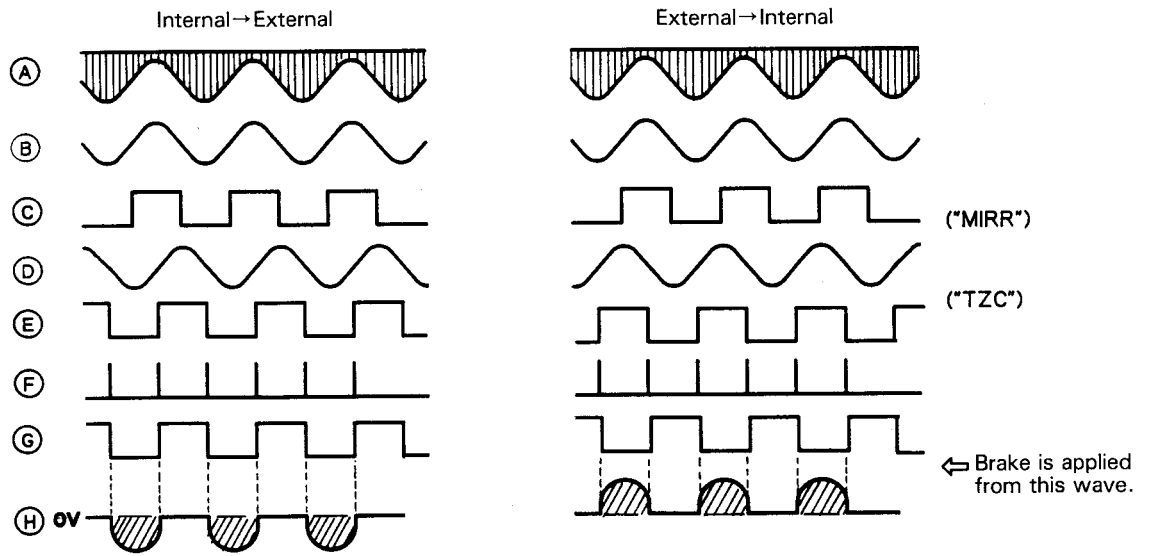

Wave forms

Fig. 32



c) Carriage equalizer

The carriage servo system generates components required for carriage feed from the equalizer characteristics shown in Figure 33 when the tracking actuator drive voltage TAO is applied.

Furthermore, the TAO low-pass filter output is applied to pin 47 (ATSC), and if the tracking actuator lens deflection is within  $\pm 25$  tracks (ATSC ON), the carriage servo is switched OFF (TM2 ON), and the carriage motor is braked by shorting the motor terminals via the PWM driver (IC651). This prevents the motor from being activated by vibration. If lens deflection exceeds +25 tracks (ATSC OFF), the carriage servo is switched ON (TM2 open), and drive is applied smoothly to the pin 14 SLO output by the slow rise controlled by the carriage equalizer time constant.

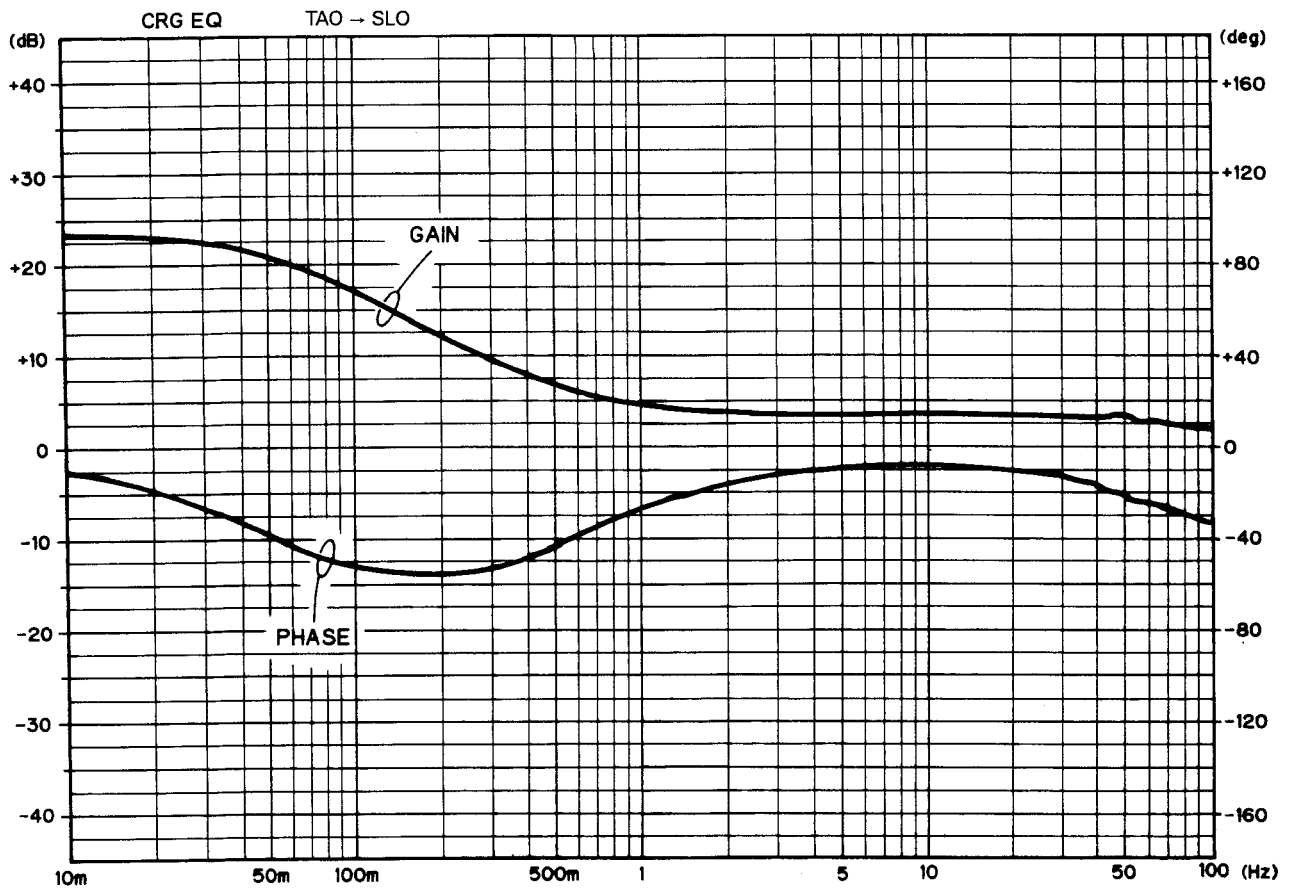
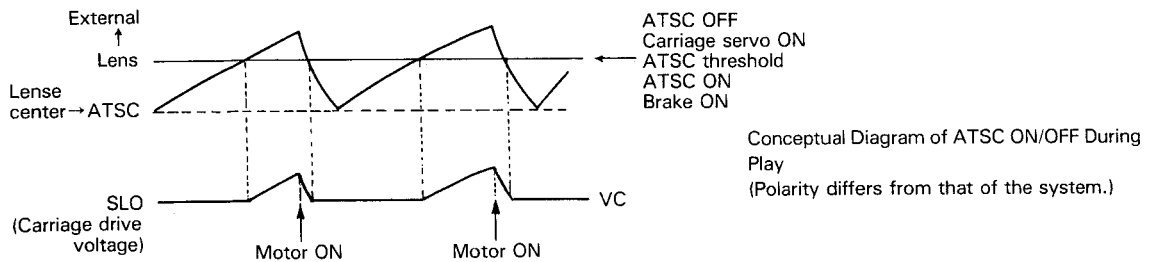

Fig. 33 Carriage equalizer

21

(4) Track jump

The CXA1082AQ auto sequencer enables tracks to be jumped 1, 10, 16, 32, 64, and 80 tracks at a time. Track searching is executed while reading sub-codes at every third group of 80 tracks.

With timing data from the system microcomputer transferred to the CXA1082AQ RAM in advance, tracks can be jumped by simple transfer of auto sequencer serial data. The auto sequencer timing charts for track jumps of 1, 10, and 2N tracks are shown in Figures 34 thru 36.

Time supervision of A thru D is executed by setting \$5X in the system microcomputer. The settings used in this system are listed below.

- A = 0.11 msec
- B = 0.23 msec
- C = 0.16 msec
- D = 10 msec (2N = 80, 64)  
7.3 msec (2N = 32, 16)

The auto sequencer is started by transferring the following \$4X.

Auto sequencer

|               | AS3 | AS2 | AS1 | AS0 |
|---------------|-----|-----|-----|-----|
| CANCEL        | 0   | 0   | 0   | 0   |
| FOCUS ON      | 0   | 1   | 1   | 1   |
| 1 TRACK JUMP  | 1   | 0   | 0   | X   |
| 10 TRACK JUMP | 1   | 0   | 1   | X   |
| 2N TRACK JUMP | 1   | 1   | 0   | X   |

(2N = 16, 32, 64, and 80)  
X=0 REVERSE  
X=1 FORWARD

Auto Sequence Timing Chart

a) 1 Track Jump

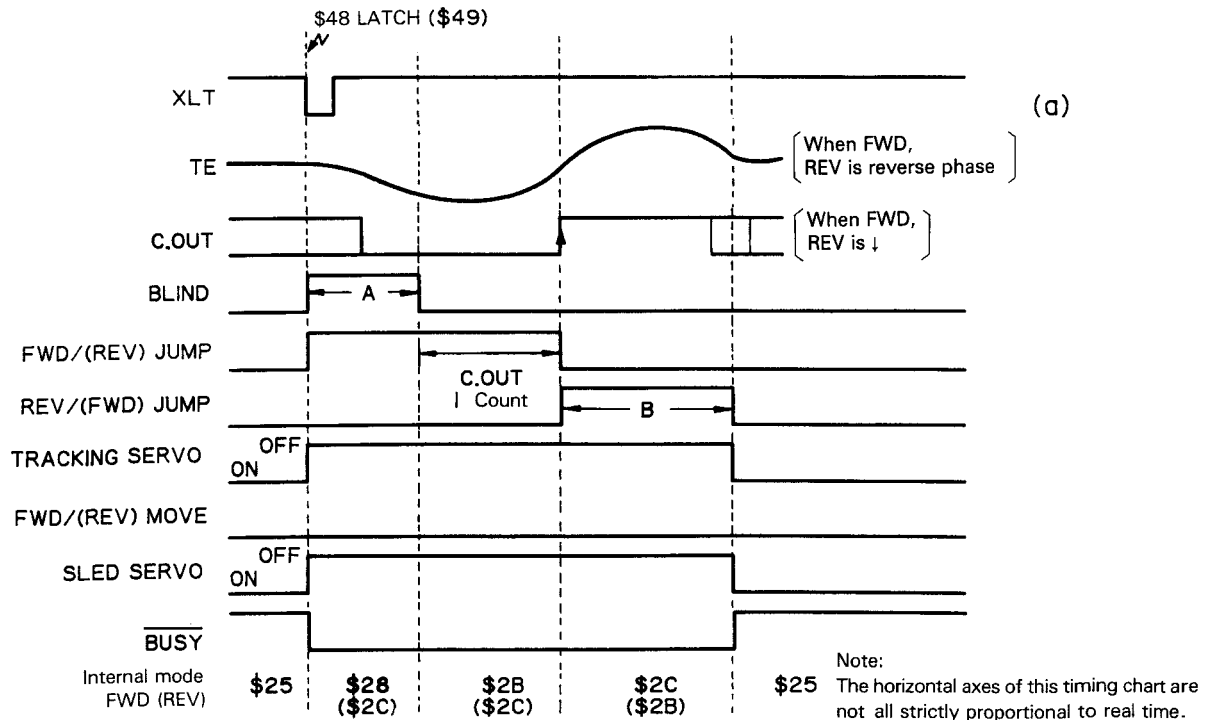

Fig. 34

**b) 10 Track Jump**

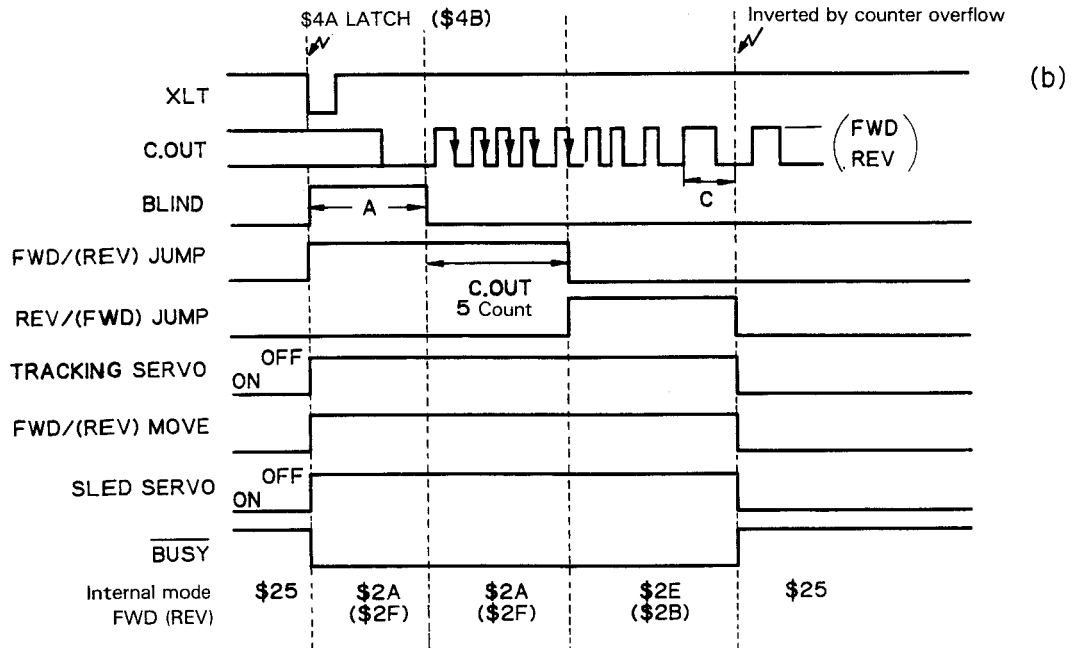

Fig. 35

**c) 2N Track Jump (2N=16, 32, 80)**

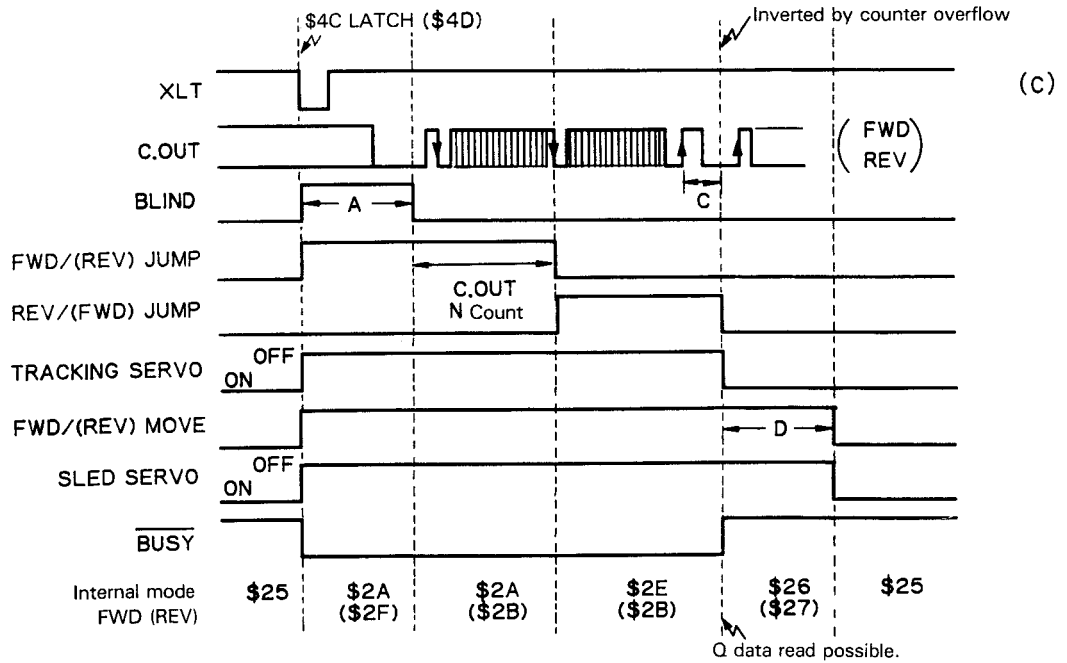

Fig. 36



### 3. CD Control Stage (IC751)

#### (1) CLV Control Commands and CLV Mode Commands

Register D

|                |    |   |                   |   |
|----------------|----|---|-------------------|---|
| DIV            | D3 | 0 | RFCK/4 and WFCK/4 | CLV-P mode phase comparator frequency       |
|                |    | 1 | RFCK/4 and WFCK/4 |   |
| T <sub>B</sub> | D2 | 0 | RFCK/32           | CLV-S and CLV-H mode bottom hold cycle time |
|                |    | 1 | RFCK/16           |   |
| T <sub>P</sub> | D1 | 0 | RFCK/4            | CLV-S mode peak hold cycle time             |
|                |    | 1 | RFCK/2            |   |
| GAIN           | D0 | 0 | - 12dB            | CLV-S and CLV-H mode MDP pin gain           |
|                |    | 1 | 0dB               |   |

Register E

| Mode   | D3-D0 | MDP pin         | MDS pin    | FSW pin | MON pin |
|--------|-------|-----------------|------------|---------|---------|
| STOP   | 0000  | L               | Z          | L       | L       |
| KICK   | 1000  | H               | Z          | L       | H       |
| BRAKE  | 1010  | L               | Z          | L       | H       |
| CLV-S  | 1110  | CLV-S           | Z          | L       | H       |
| CLV-H  | 1100  | CLV-H           | Z          | L       | H       |
| CLV-P  | 1111  | CLV-P           | CLV-P      | Z       | H       |
| CLV-A  | 0110  | CLV-S or CLV-P  | Z or CLV-P | L or Z  | H       |
| CLV-A' | 0101  | CLV-S' or CLV-P | Z or CLV-P | L or Z  | H       |

CLV mode command data table Z: High impedance

These signals are all CLV servo related. IC751 (mechanism/system controller) selects the respective CLV modes and passes the commands to IC701. The IC701 outputs include the MDP pin (speed and phase synchronization control), MDS pin (speed synchronization control), FSW pin (filter time constant switching), and the MON pin (motor ON/OFF switching control). Since these control pin outputs are modulated by pulse width, the signals are passed through a low-pass filter (incorporated in IC601) for conversion to DC signals before being applied to the PWM driver (IC652). The MON pin is connected to pin 15 of IC652. The spindle driver is activated when "H" is applied to this pin, but there is no output when "L" is applied. (This is to prevent the driver from being activated by offset of the IC601 SPDLO pin.)

- Stop mode  
Stop mode enables the spindle motor to remain still during DD converter (IC951) operation. The IC701 outputs are MDP = "L", MDS = "Z", FSW = "L", and MON = "L". Pin 39 (SPDLO) of IC601 is at 2.5V.
- Kick mode  
Kick mode compels the spindle motor to rotate forward for simple PLL activation. Pin 39 (SPDLO) of IC601 is at 3.2 to 3.3V.

- Brake mode

When stopping the spindle motor during forward rotation, brake mode reduces the time taken to stop the motor by applying a reverse drive voltage. Pin 39 (SPDLO) is at 1.6 to 1.7V. During brake mode, the spindle motor is controlled by spindle sub-control.

- CLV-S mode

CLV-S mode is a "rough" servo mode used if the EFM- PLL circuit lock is disengaged during motor starting, track jumping, or track search.

- CLV-H mode

CLV-H mode is used if the RF signal becomes intermittent during high-speed searches. (Test mode only)

- CLV-P mode

CLV-P mode is the normal playback mode selected when the PLL is locked.

- CLV-A mode

When CLV-P mode becomes unstable due to vibration or disc scratches, or when several tracks are jumped, CLV-P mode is switched to CLV-S mode. After the PLL has been activated, CLV-S mode is automatically switched back to CLV-P mode. This CLV-A mode is not used.

- CLV-A' mode

The difference between CLV-A mode and CLV-A' mode lies in the "rough" servo. Whereas the CLV-A mode rough servo involves measurement of the EFM pattern by crystal, the CLV-A' mode rough servo involves measurement by the VCO instead of crystal. Otherwise, both modes are identical.

**\* Normal mode**

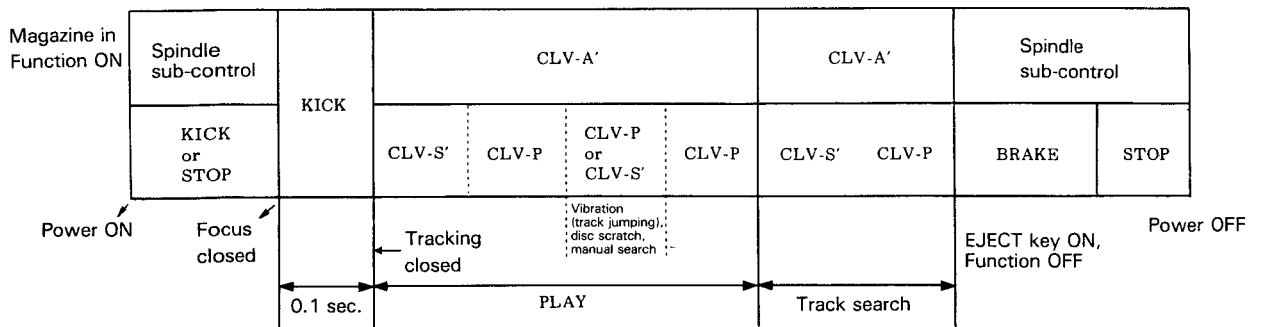

Fig. 37 Spindle motor control mode selection (Normal mode)

**\* Test mode**

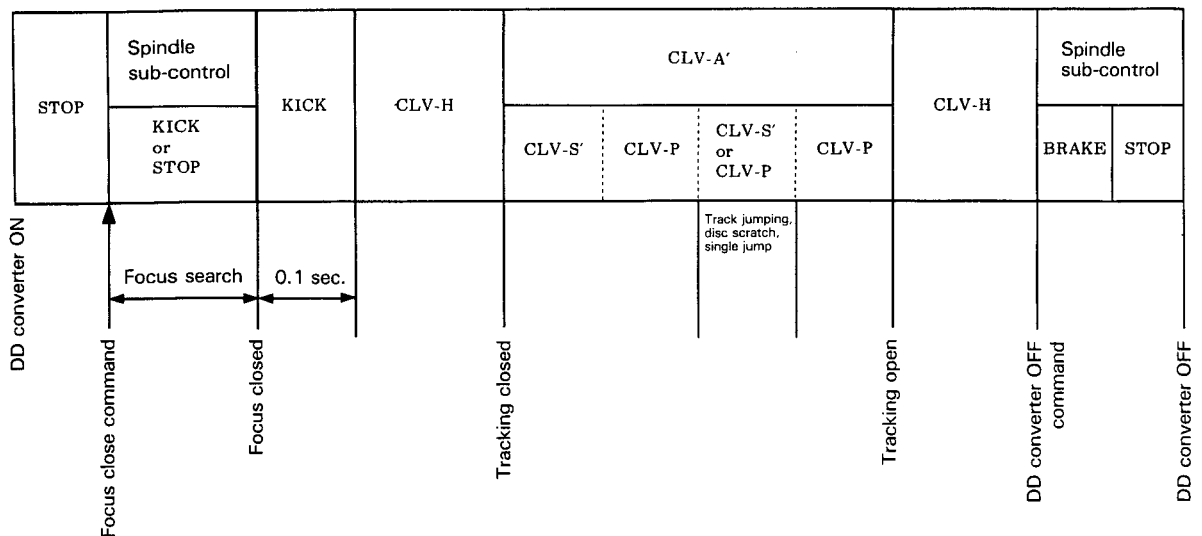

Fig. 38 Spindle motor control mode selection

#### 4. Demodulator (IC701)

The demodulator consists of a single-chip LSI (CXD1135Q) connected to a number of peripheral circuits. The major functions are listed below.

1. Bit clock reproduction by EFM - PLL circuit
2. EFM data demodulation
3. Frame synchronizing signal detection, protection, and insertion
4. Powerful error detection and correction
5. Average value and previous hold value interpolation
6. Sub-code signal demodulation, and sub-code Q error detection
7. Spindle motor CLV servo
8. 8-bit tracking counter
9. Serial bus CPU interface
10. Built-in digital filter (35-stage)

#### 5. D/A Converter (IC703)

The purpose of IC703 is to convert 16 bit serial data to left and right channel voltage signals. LRCK, BLCK, APTL, APTR, and DATA signals are received from IC701. 16 bits of input data from the logic interface stage are expanded and converted to 17 bits of data by a data conversion unit in the LSI. This data is divided into 8 upper and 9 lower bits used to control a switch connected to a resistance string. The respective outputs obtained with the divided data are combined, and the output then separated into left and right channels by using the APTL and APTR signals. These outputs are then passed via respective sample hold circuits to the LOUT and ROUT outputs.

#### 6. Audio Stage

The IC703 contains spectral components outside the audible frequency range. These components are removed by IC704 (low-pass filter: 0.8dB gain). This IC also includes a built-in de-emphasis circuit with the ON/OFF switching being controlled by applying +5V and 0V respectively to pins 5 and 17. The ON/OFF status is read from disc sub-code with the output signal obtained from IC751. This output is driven by Q706 to control the de-emphasis pin. IC704 is also equipped with

an isolator amplifier designed to cancel noise generated in the ground line of the connecting cable when CDX-M100 is connected to a cassette tape deck or other audio component. GIN is connected to drop the CDX-M100 GND to ground, and GOUT is connected to drop the cassette deck GND to ground. When CDX-M100 is used independently, measurements must be made with GIN and GOUT short-circuited.

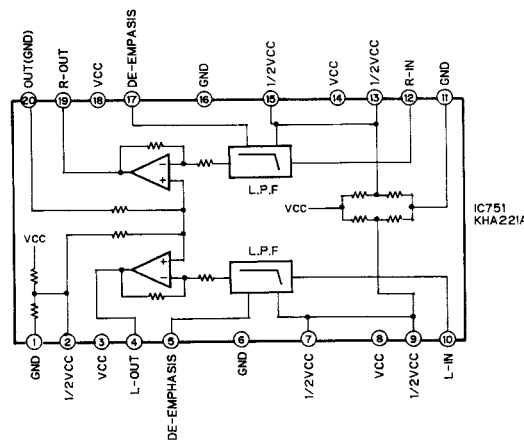

Fig. 39

#### 7. Spindle Sub-control (SPC)

In this system, disc rotation must be controlled by another means until the disc reaches a certain speed and focus is achieved. Using the circuit shown in the Fig. 40, the spindle motor is controlled by simple means during focus search, and until the disc stops after the EJECT key is pressed and function is switched OFF.

The bridge circuit formed by R680, the spindle motor DCR, R678, and R679 is balanced while the spindle motor is stationary. One the spindle motor commences to rotate, a counter electromotive voltage which is inversely proportional to the rpm speed is generated in the motor, thereby upsetting the balance

between points A and B. The potential at A becomes higher than that at B. As a result, the IC656 1/2, 2/2 comparator is changed to "H", this output (SPC) being passed to IC751 (mechanism/system controller). If SPC is "H", a STOP command is passed to IC701. SM- and SM+ (IC652) are connected to ground level during the stop interval, and (A) is compared with (C). If (A) is lower than (C), the comparator (SPC) is switched to "L", resulting in a KICK command being passed from IC751 to IC701. In this "rough" disc rotation control, the above process is repeated until focus is attained.

When stopping the disc, a brake signal is generated when the comparator is "H", but a stop signal is generated when the comparator is changed to "L", thereby braking the disc. Q652 is used to activate the brake adjustment resistor R692 while the brake is being applied. Q651 and Q653 apply a reset signal to this circuit. SPCO is "H" when braking. And although SPC is also active during normal playback and search operations, IC751 is not involved.

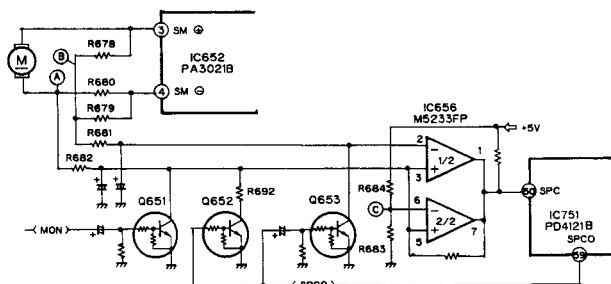

Fig. 40

**Focus search and spindle sub-control**

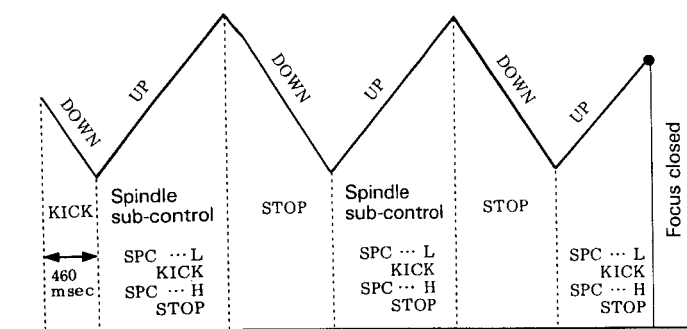

Fig. 41 Focus Search and Spindle Sub-control

**8. VCO Loop Filter (8.64MHz VCO)**

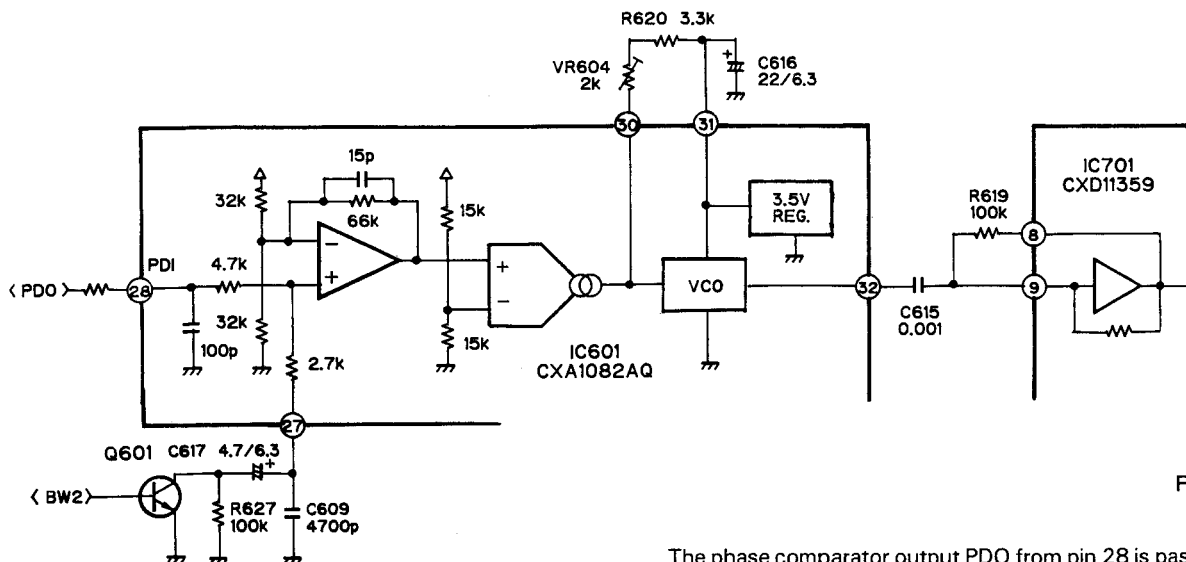

Fig. 42

The phase comparator output PDO from pin 28 is passed to the loop filter for removal of the PWM carrier prior to V- I conversion. This is then added to the free-run frequency setting current from pin 30 for use in VCO frequency control. The VCO free-run frequency is more or less inversely proportional to the resistance between pins 30 and 31.

9. Spindle Servo, LPF

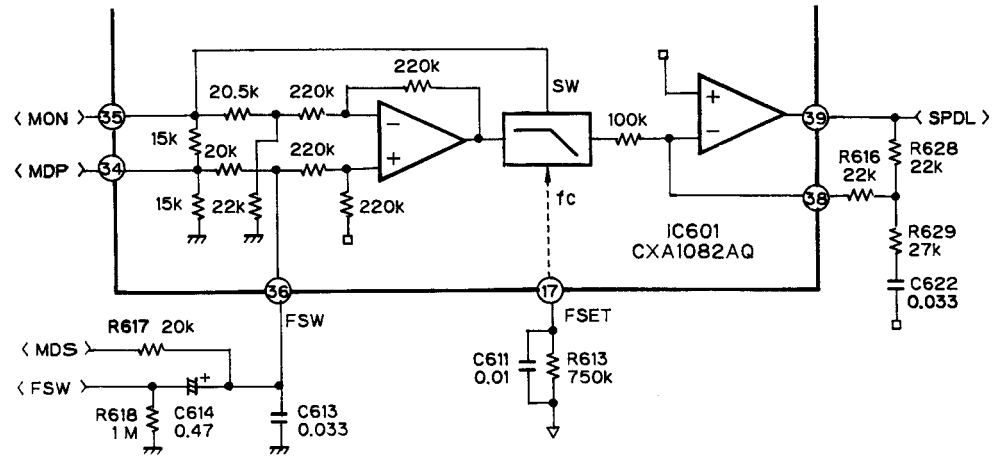

Fig. 43 Spindle servo, LPF

With a 2-stage low-pass filter consisting of the 200Hz LPF (0.033 $\mu$ F and 20 k $\Omega$ ) connected to pin 36 and the internal LPF (fc to 200Hz with 510 k $\Omega$  connected to pin 17), the carrier components of the CLV servo error signals MDS and MDP are removed.

In CLV-S, -H mode, FSW = "L", and the fc of the low-pass filter connected pin 36 is lowered for greater filter effect.

## 5. ADJUSTMENT

### 1) Precautions

- Unlike other CD players, the CDX-M100 uses a single power supply (+5V) for the DD converter. The signal reference potential, therefore, is connected to pin no.14 (approx. 2.5V) of IC351 (CXA1081M) instead of GND. (VC or VREF at test point)

If VC and GND are connected to each other by mistake during adjustments, not only will it be impossible to measure the potential correctly, but the servo will malfunction and a severe shock will be applied to the pick-up. To avoid this, take special note of the following.

Do not connect the negative probe of the measuring equipment to VC and GND together. It is especially important not to connect the channel 1 negative probe of the oscilloscope to VC with the channel 2 negative probe connected to GND.

And since the frame of the measuring instrument is usually at the same potential as the negative probe, change the frame of the measuring instrument to floating status.

If by accident VC comes in contact with GND, immediately switch the DD converter or power OFF.

- Always make sure the DD converter is OFF when connecting and disconnecting the various filters and wiring required for measurements.
- Before proceeding to further adjustments and measurements after switching DD converter ON, let the player run for about one minute to allow the circuits to stabilize.

- When loading and unloading discs during adjustment procedures, always wait for the disc to be properly clamped or ejected before pressing the another key. Otherwise, there is risk of the actuator being destroyed. (For example, do not press the **P.G** key while a disc is being moved from magazine to clamp after DD converter is switched ON in steps 3 thru 5 of Tracking Balance Adjustment I. Nor should the **EJECT** key (in M100) be pressed during focus closed status.)
- 2) Since CDX-M100 is used in combination with a multi-CD control section such as KEX-M700, all adjustment key operations are executed at that control section. The KEX-M700 test mode starting procedure and key operations are included for reference purposes. All keys mentioned in the main text are KEX-M700 keys.
  - Test mode starting procedure  
Switch back-up ON or press the CLEAR button while pressing the VOL + and VOL - keys together.
  - Test mode cancellation  
Press the CDX-M100 CLEAR button, followed by the KEX-M700 CLEAR button. (Or switch the KEX-M700 and CDX-M100 back-up OFF.)

• Flow Chart

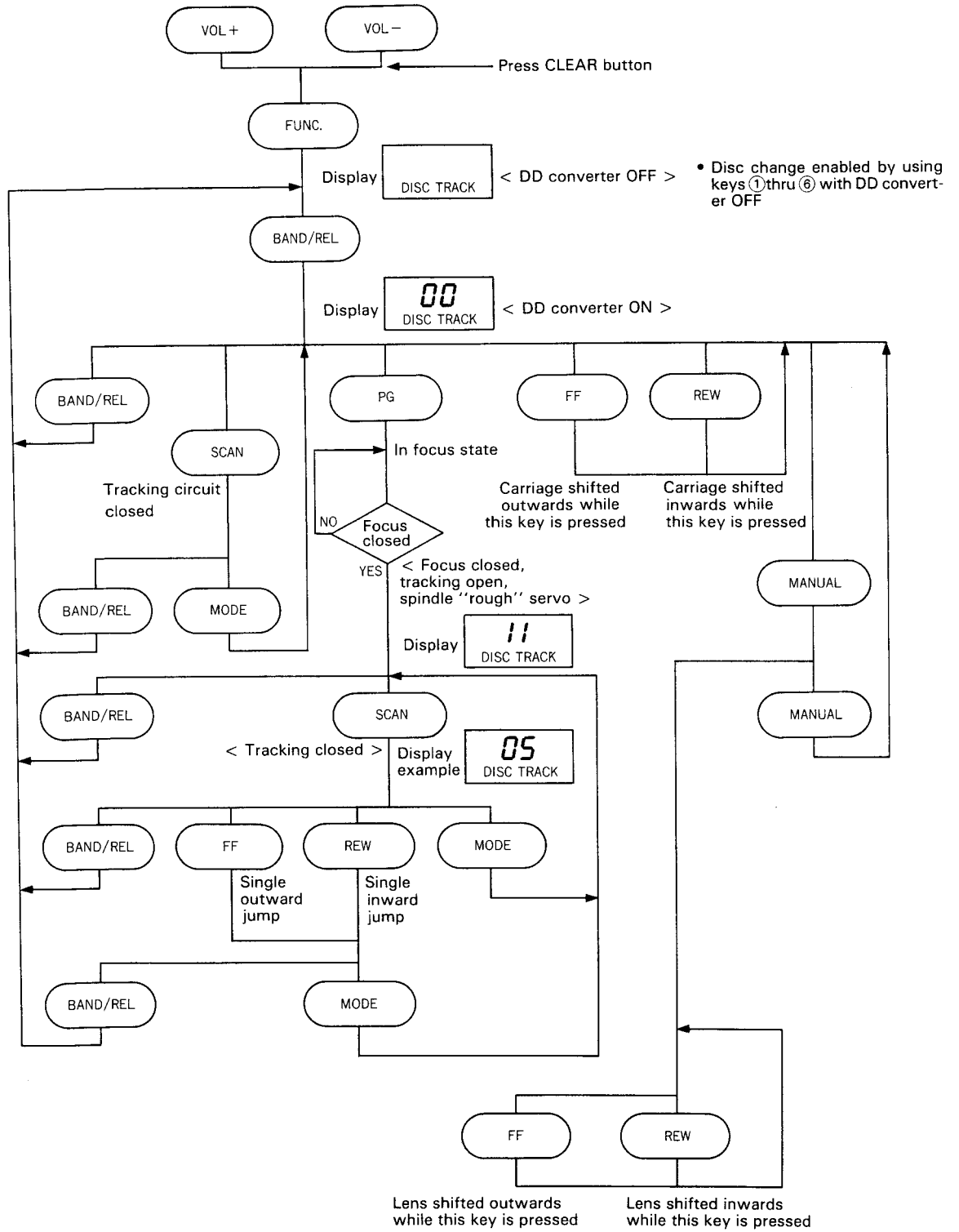

Fig. 44

• Adjustment Points

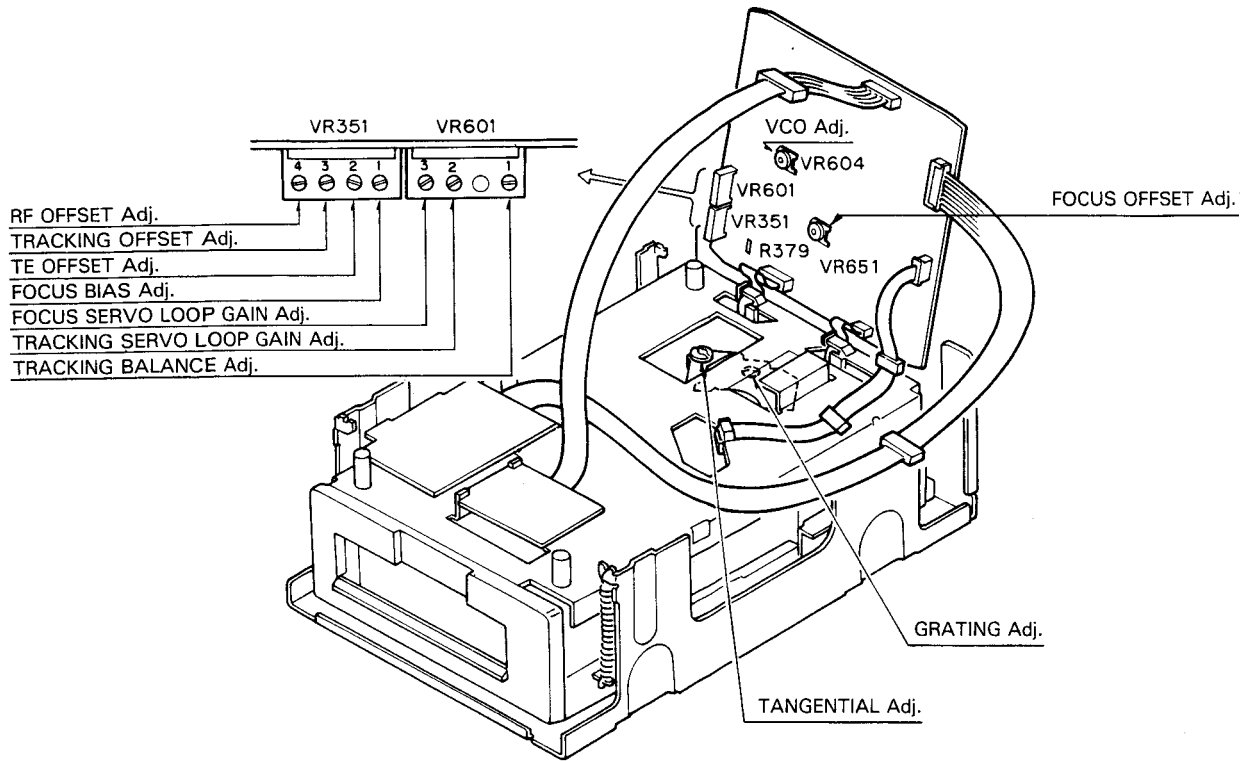

Fig. 45



### 5.1 Focus Offset Adjustment

- Purpose: To adjust the electrical offset of the focus amplifier to zero.
- Maladjustment symptoms: No focus closing

- |  |   |
|--|---|
| <ul style="list-style-type: none"> <li>● Measuring equipment/ jigs</li> <li>● Measuring point</li> <li>● Test disc and setting</li> <li>● Adjustment position</li> </ul> | <ul style="list-style-type: none"> <li>● Multi-meter or oscilloscope</li> <li>● FEO2</li> <li>● Empty magazine, test mode</li> <li>● VR651</li> </ul> |
|--|---|

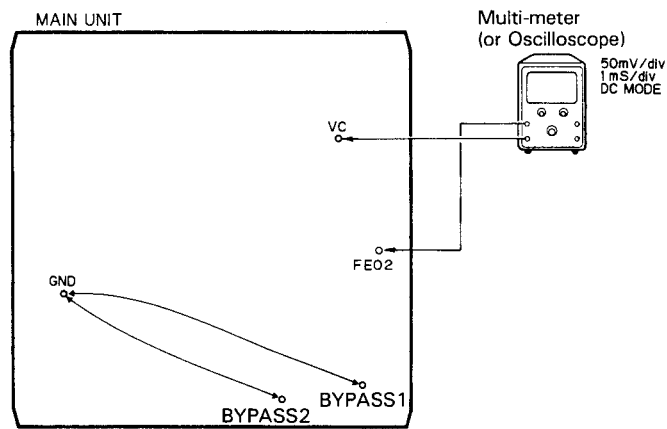

Fig. 46

#### Adjustment Procedure

1. Connect BYPASS 1 and BYPASS 2 to GND.
2. Switch DD converter ON.
3. Using VR651, adjust the FEO2 DC voltage in reference to VC to a value of  $0 \pm 25\text{mV}$ .

**5.2 VCO Free Run Frequency Adjustment**

|   |   |
|---|---|
| <ul style="list-style-type: none"> <li>● Purpose: To adjust the EFM decoder reference clock free- run frequency to a suitable value</li> <li>● Maladjustment symptoms: Spindle lock not possible, distorted sound or no sound at all</li> </ul>   |   |
| <ul style="list-style-type: none"> <li>● Measuring equipment/ jigs</li> <li>● Measuring point</li> <li>● Test disc and setting</li> <li>● Adjustment position</li> </ul>  | <ul style="list-style-type: none"> <li>● Frequency counter, extension cables (three types)</li> <li>● Pin no.70 (<math>\overline{\text{PLCK}}</math>) of IC701 (CXD1135Q)</li> <li>● Empty magazine • Test mode</li> <li>● VR604</li> </ul> |
| <p>The diagram shows a rectangular box labeled 'MAIN UNIT'. Inside the box, there are several test points: ASY at the top right, PDI below it, OVC to the right of PDI, PLCK in the middle, GND at the bottom left, BYPASS1 and BYPASS2 at the bottom right. A 'Frequency Counter' is shown to the right of the box, with a digital display showing '4350'. A wire connects the counter's input to the PLCK pin. Another wire connects the counter's ground to the GND pin. There are also curved lines representing connections between ASY and GND, and between PDI and OVC.</p>  |   |
| <p>Fig. 47</p>  |   |
| <p><b>Adjustment Procedure</b></p> <ol style="list-style-type: none"> <li>1. Connect pin no.26 (TP ASY) of IC351 to GND.<br/>Connect BYPASS 1 and BYPASS 2 to GND.</li> <li>2. Connect pin no. 1 (TP VC) of IC601 to pin no.28 (TP PDI).</li> <li>3. Switch DD converter ON while in test mode.</li> <li>4. Connect the frequency counter to pin no.70 (TP <math>\overline{\text{PLCK}}</math>) of IC701 (CXD1135Q).</li> <li>5. Adjust VR604 to obtain a frequency of <math>4.35 \pm 0.005\text{MHz}</math>.</li> <li>6. Switch DD converter OFF.</li> <li>7. Disconnect the leads connecting TP VC to TP PDI, and TP ASY to GND.</li> </ol> <p>Note: Connect TP VC and TP PDI with leads kept as short as possible.</p> <p>Note: Connect the frequency counter ground to TP GND as shown in the figure.</p> |   |

### 5.3 RF Offset Adjustment

- Purpose: To adjust the RF amplifier offset to a suitable value
- Maladjustment symptoms: Focus closure fails readily

- |  |   |
|--|---|
| <ul style="list-style-type: none"> <li>● Measuring equipment/ jigs</li> <li>● Measuring point</li> <li>● Test disc and setting</li> <li>● Adjustment position</li> </ul> | <ul style="list-style-type: none"> <li>● Oscilloscope</li> <li>● RFO</li> <li>● Empty magazine</li> <li>● VR351-4 (RFO)</li> <li>● Test mode</li> </ul> |
|--|---|

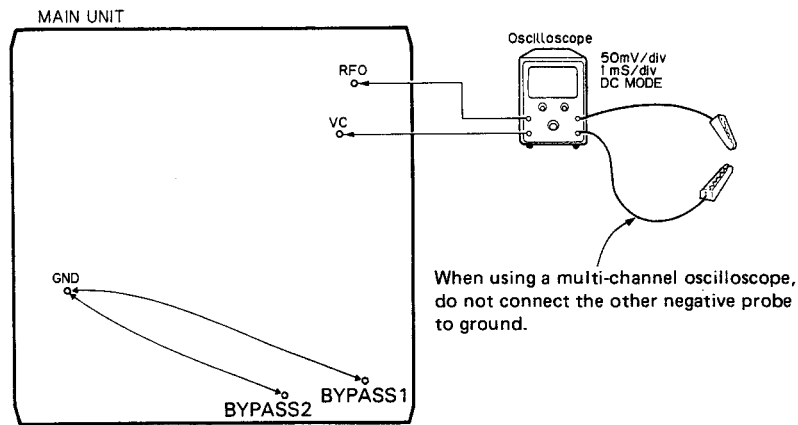

Fig. 48

#### Adjustment Procedure

1. Connect BYPASS 1 and BYPASS 2 to GND.
2. Switch DD converter ON.
3. Using the oscilloscope, measure the RFO DC voltage in reference to VC, and adjust VR351-4 (RFO) to obtain a reading of  $+250 \pm 25\text{mV}$ .

**5.4 Tracking Offset Adjustment**

- Purpose: To adjust the electrical offset of the tracking amplifier to zero
- Maladjustment symptoms: Search times too long, carriage run-away

- |   |   |
|---|---|
| <ul style="list-style-type: none"> <li>● Measuring equipment/jigs</li> <li>● Measuring point</li> <li>● Test disc and setting</li> <li>● Adjustment position</li> </ul> | <ul style="list-style-type: none"> <li>● Oscilloscope</li> <li>● TAO low-pass filter output</li> <li>● Empty magazine</li> <li>● VR351-3 (TO)</li> <li>● Test mode</li> </ul> |
|---|---|

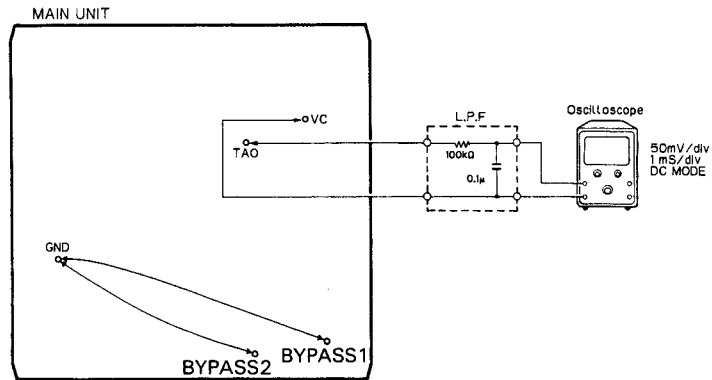

Fig. 49

**Adjustment Procedure**

1. Insert a low-pass filter between TAO and VC.
2. Check that BYPASS 1 and BYPASS 2 are connected to GND.
3. Switch DD converter ON.
4. Using the oscilloscope, measure the TAO LPF output DC voltage in reference to VC, and adjust VR351-3 (TO) to obtain a reading of  $0 \pm 25\text{mV}$ .  
The low-pass filter may be left in place for later adjustments.

### 5.5 TE Offset Adjustment - I

- Purpose: To adjust the electrical offset of the tracking servo to zero.
- Maladjustment symptoms: Search times too long, carriage run-away

- |  |  |
|--|--|
| <ul style="list-style-type: none"> <li>● Measuring equipment/ jigs</li> <li>● Measuring point</li> <li>● Test disc and setting</li> <li>● Adjustment position</li> </ul> | <ul style="list-style-type: none"> <li>● DC voltmeter</li> <li>● TAO low-pass filter output</li> <li>● Empty magazine</li> <li>● VR351-2 (TEO)</li> <li>● Test mode</li> </ul> |
|--|--|

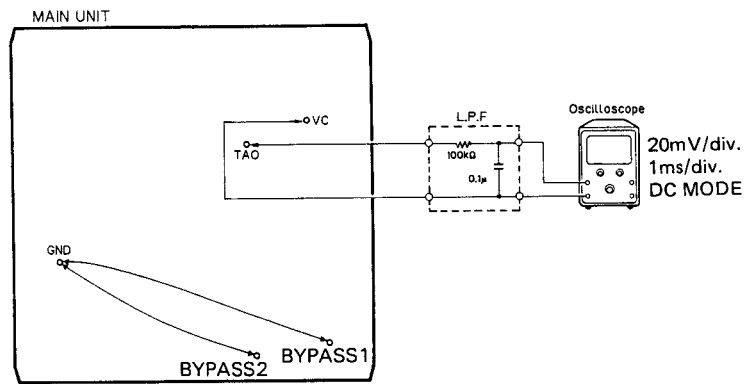

Fig. 50

#### Adjustment Procedure

1. Check that BYPASS 1 and BYPASS 2 are connected to GND.
2. Switch DD converter ON while in test mode.
3. Press the **SCAN** key to close tracking.
4. Using VR351-2 (TEO), adjust the TAO LPF output DC voltage in reference to VC to a value of  $0 \pm 10\text{mV}$ .
5. Switch DD converter OFF.

**5.6 Tracking Balance Adjustment-I**

- Purpose: To adjust the tracking servo offset to zero.
- Maladjustment symptoms: Search times too long, poor playability, carriage run-away

- |  |  |
|--|--|
| <ul style="list-style-type: none"> <li>● Measuring equipment/ jigs</li> <li>● Measuring point</li> <li>● Test disc and setting</li> <li>● Adjustment position</li> </ul> | <ul style="list-style-type: none"> <li>● Oscilloscope</li> <li>● TEY (Tracking error signal), low-pass filter output</li> <li>● SONY TYPE 4 (or TYPE 3) • Test mode</li> <li>● VR601-1 (T. BAL)</li> </ul> |
|--|--|

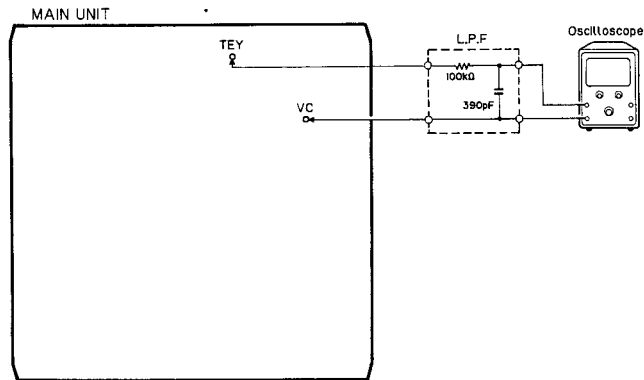
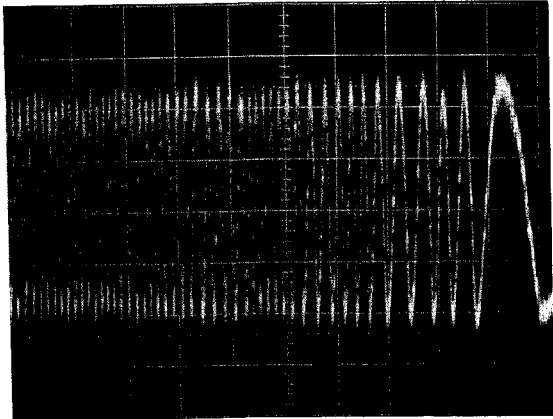

Fig. 51

**Adjustment Procedure**

1. After checking that DD converter is OFF, connect the low-pass filter as shown in the diagram.
2. Disconnect BYPASS 1 and BYPASS 2 from ground.
3. Set the test disc (SONY TYPE 4) in magazine tray 6 and load the magazine. Switch DD converter ON.
4. Using the **[FF]** or **[REW]** key, move the pick-up to about the center of the signal surface.
5. Press the **[PG]** key to close focus.
6. Using an oscilloscope, observe the TEY signal in respect to VC. Then adjust VR601-1 (T.BAL) to set the positive and negative amplitudes to the same levels. (See Fig. 52-54.)
7. Switch the power OFF.  
The low-pass filter may be left in place for later adjustments.



+5% NG

Fig. 52

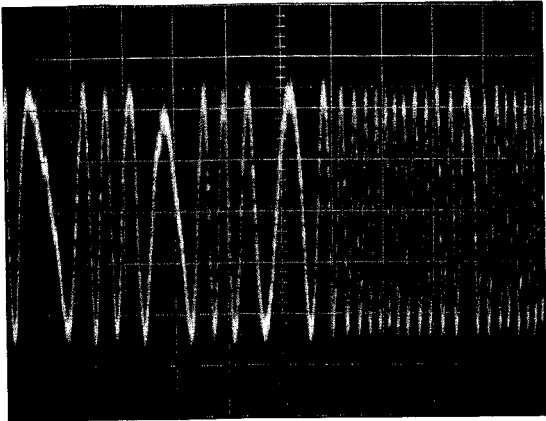

±0% OK

Fig. 53

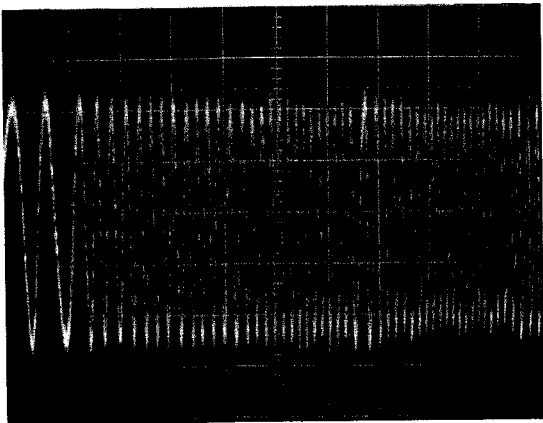

-5% NG

Fig. 54

10ms/div.  
0.2V/div.  
DC Mode

**5.7 Tangential Skew Check**

- Purpose: To check whether tangential skew has been misaligned or not when replacing the pick-up unit.
- Maladjustment symptoms: No disc playback; track jumping

- |  |  |
|--|--|
| <ul style="list-style-type: none"> <li>● Measuring equipment/ jigs</li> <li>● Measuring point</li> <li>● Test disc and setting</li> <li>● Adjustment position</li> </ul> | <ul style="list-style-type: none"> <li>● Oscilloscope, extension connectors (three types), screwdriver</li> <li>● RFO</li> <li>● SONY TYPE 4 (or TYPE 3) • Normal mode</li> <li>● Pick-up tangential adjustment screw</li> </ul> |
|--|--|

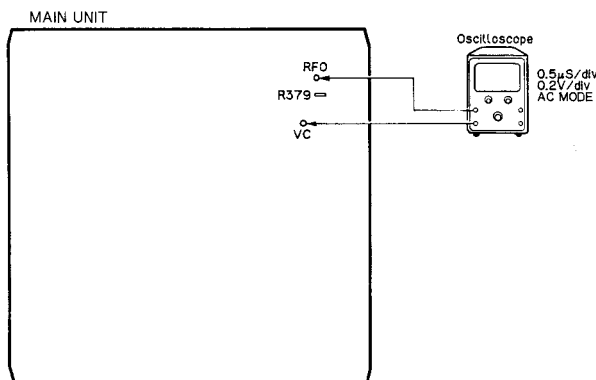

Fig. 55

**Adjustment Procedure (with R379 removed)**

1. Remove R379 (but reconnect after completing adjustment).
2. Play tune TNO 7 in normal mode. (TYPE 3: TNO 23)
3. Check that the valley at the 11T section of the RF waveform is flat.
4. If out of adjustment, readjust to obtain a flat RF waveform. (See Fig. 56-61) Take care not to knock the pick-up with the screwdriver at this stage. (This kind of accident can result in loss of focus.)
5. Switch the power OFF and reconnect R379.
6. Apply "screw-lock" to the tangential adjustment screw.
7. After adjusting tangential skew, also adjust the grating.
8. If tangential skew is seriously out of adjustment, carriage stopping and run-away tend to occur in normal mode. In this case,
  - a) Switch to test mode,
  - b) Shift the pick-up to signal surface center using **[FF]** or **[REW]** key,
  - c) Press the **[PG]** key to close focus.
  - d) Press the **[SCAN]** key to close tracking.

- e) Observe RFO in respect to VC, and turn the tangential adjustment screw to obtain a flat waveform at the 11T section.
- f) Repeat the adjustment resuming from step 2.



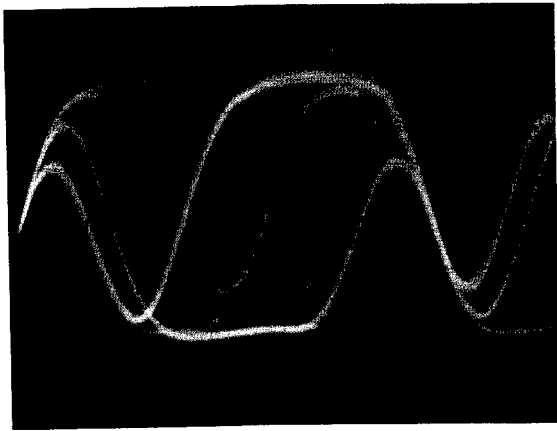

NG Fig. 56

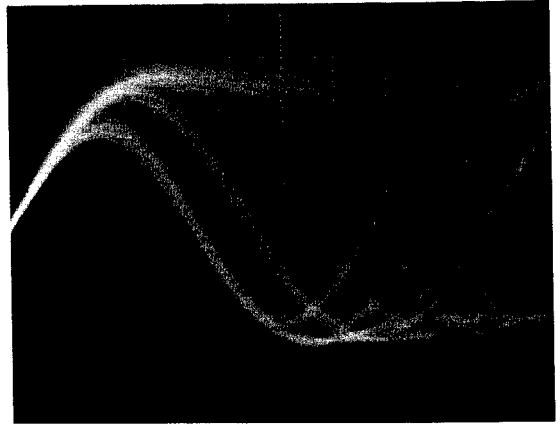

NG Fig. 57

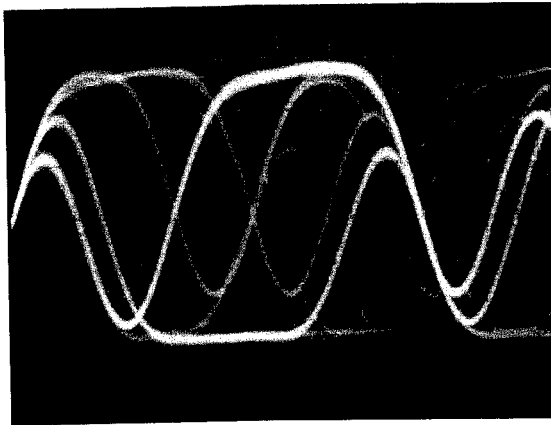

OK Fig. 58

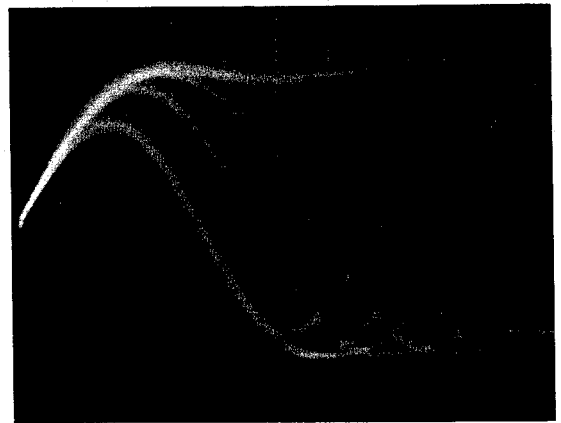

OK Fig. 59

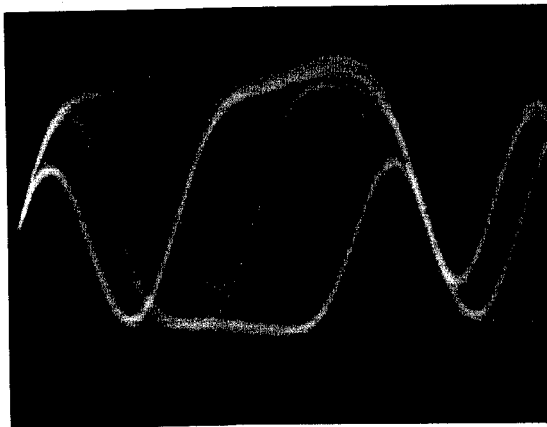

NG Fig. 60

Play tune TNO 7 (TYPE4)

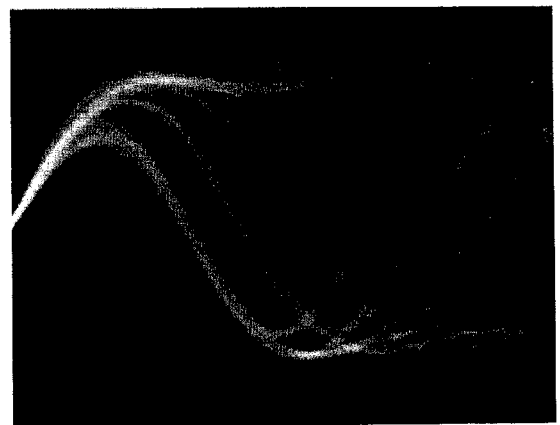

NG Fig. 61

Play tune TNO 12 (TYPE4)

**Adjustment Procedure (without R379 removed)**

1. Play tune TNO 12 in normal mode. (TYPE 3: TNO 14)
2. Turn the tangential adjustment screw to obtain a good RF waveform eye pattern. Turn the adjustment screw both clockwise and counterclockwise to points where the eye pattern deteriorates, and take the midway point as the adjustment point. As a general guide, look for an overall clear waveform, and one of the diamond shapes in the eye pattern. The diamond shapes should appear in fine lines at the point of optimum adjustment. Take care not to knock the pick-up with the screwdriver at this stage. (This kind of accident can result in loss of focus.) (See Fig. 62-64)
3. Apply "screw-lock" to the tangential adjustment screw.
4. After adjusting tangential skew, also adjust the grating.

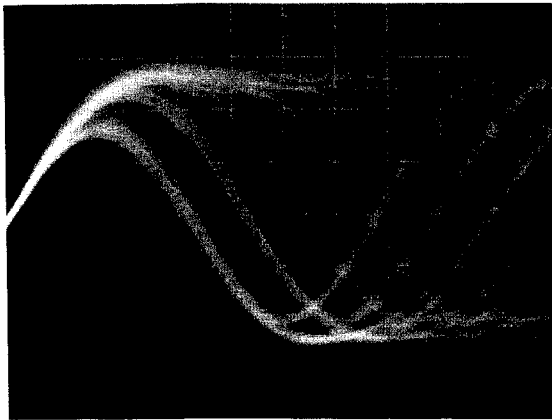

NG Fig. 62

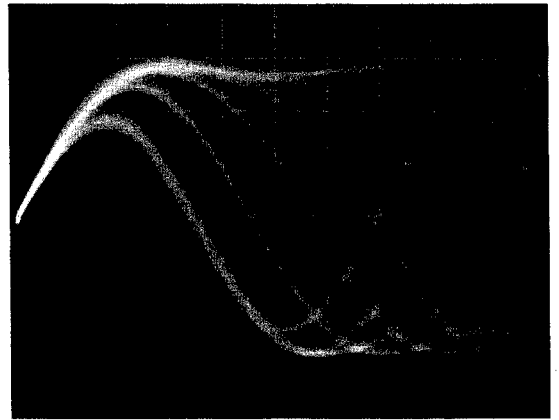

OK Fig. 63

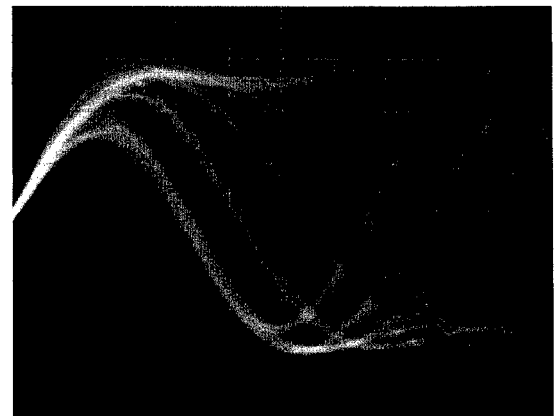

NG Fig. 64

### 5.8 Grating Adjustment

- Purpose: The grating may need adjustment in a replaced pick-up assembly.
- Maladjustment symptoms: No disc playback; track jumping

- |  |   |
|--|---|
| <ul style="list-style-type: none"> <li>● Measuring equipment/ jigs</li> <li>● Measuring point</li> <li>● Test disc and setting</li> <li>● Adjustment position</li> </ul> | <ul style="list-style-type: none"> <li>● Oscilloscope, clock driver, grating adjustment filter (bandpass filter), AC millivoltmeter, two low-pass filters</li> <li>● TEY, E LPF output, F LPF output</li> <li>● SONY TYPE 4 (or TYPE 3) • Test mode</li> <li>● Pick-up grating adjustment hole</li> </ul> |
|--|---|

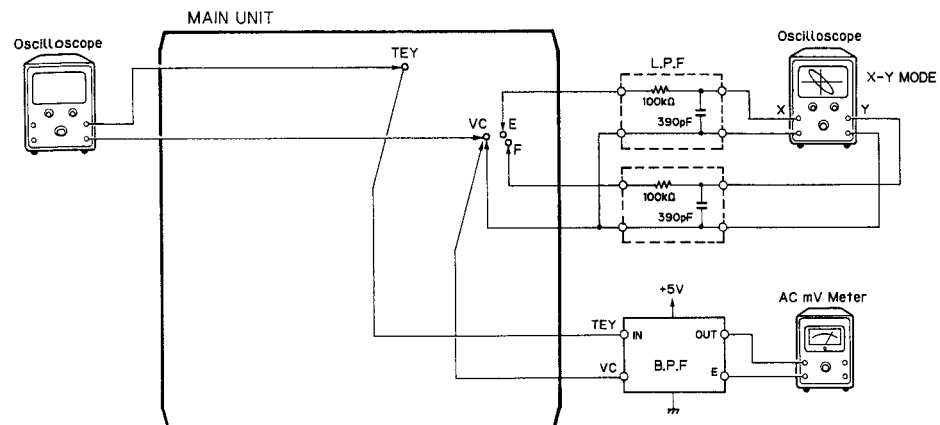

Fig. 65

#### Adjustment Procedure

1. Connect a low-pass filter (100k, 390p) to test points E, F, and VC as shown in the above diagram.
2. Switch DD converter ON in test mode, and load a disc.
3. Press the **PG** key to close focus.
4. Press the **SCAN** key to close tracking.
5. Using the **FF** or **REW** key, move the pick-up to about the center of the signal surface (tune TNO 6). (TYPE 3: TNO 7)
6. Press the **MODE** key to open tracking.
7. While monitoring the TEY filter output by AC millivoltmeter, turn the grating adjustment hole slowly. The AC voltage increases and decreases while turning the screw. Search for the minimum voltage level. (This corresponds to the position where the grating is on a track, and is referred to as the null point.)
8. Then while monitoring TEY by oscilloscope, turn the driver slowly clockwise from the null point (as seen from under the pick-up) until the first waveform peak amplitude is reached. (See Fig. 67-72)

9. With the E low-pass filter output connected to the X axis of the oscilloscope, and the F low-pass filter output connected to the Y axis, apply an input in AC mode and observe the Lissajous figure.
10. Using the driver, adjust the Lissajous figure to a single line (or as close as possible).
11. Switch DD converter OFF and remove the filters.

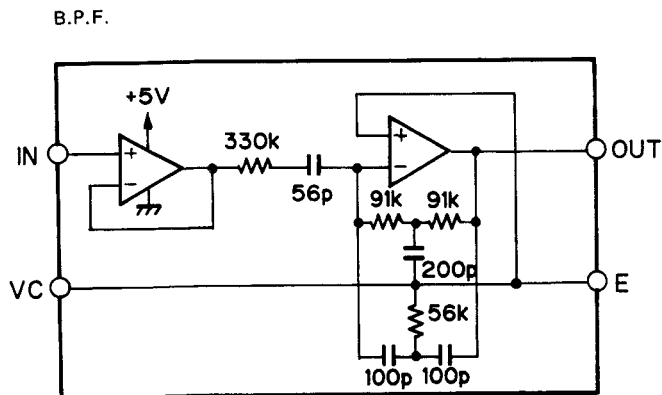

Fig. 66

TEY waveform 10ms/div, 500mV/div

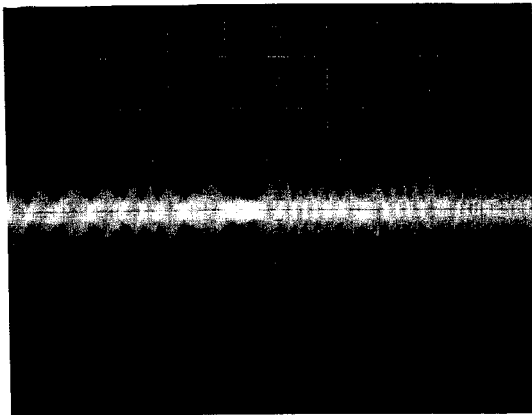

Fig. 67

Null Point

Lissajous figure (AC input)  
Horizontal axis E 20mV/div  
Vertical axis F 20mV/div

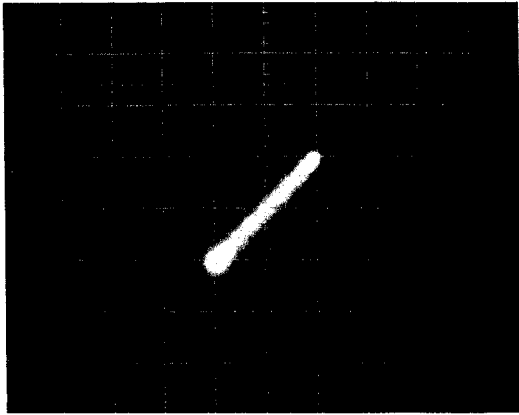

Fig. 68



"Rough" adjustment

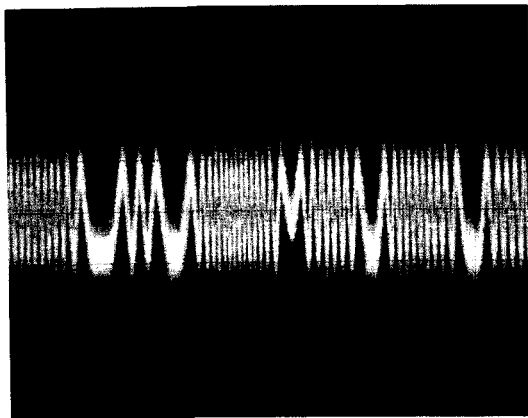

Fig. 69



Fig. 70



Final adjustment

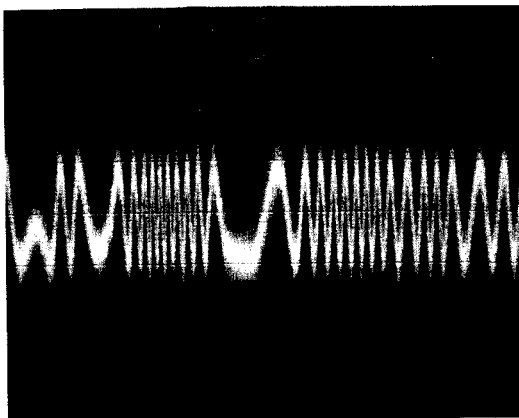

Fig. 71



Fig. 72

**5.9 Focus Bias Adjustment**

- Purpose: To adjust the focus servo bias to an optimum value
- Maladjustment symptoms: Focus closing difficulty, poor playability

- |   |   |
|---|---|
| <ul style="list-style-type: none"> <li>● Measuring equipment/jigs</li> <li>● Measuring point</li> <li>● Test disc and setting</li> <li>● Adjustment position</li> </ul> | <ul style="list-style-type: none"> <li>● Oscilloscope</li> <li>● RFO</li> <li>● SONY TYPE 4 (or TYPE 3) • Normal mode</li> <li>● VR351-1 (FEB)</li> </ul> |
|---|---|

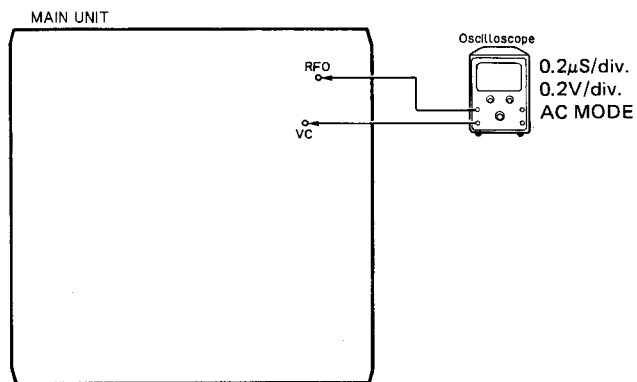
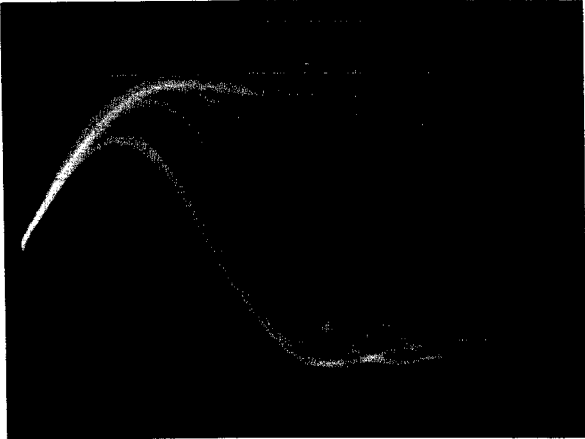

Fig. 73

**Adjustment Procedure**

1. Play tune TNO 12 in normal mode. (TYPE 3: TNO 14)
2. Observe RFO in respect to VC in the oscilloscope, and adjust VR351-1 (FEB) to obtain maximum RF and optimum eye pattern. (See Fig. 74 and 75)



OK

Fig. 74

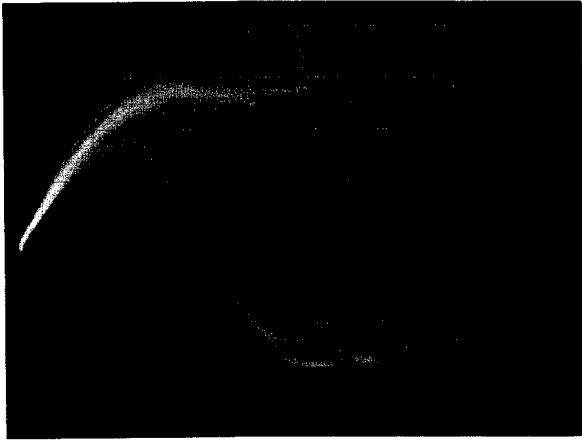

0.2 $\mu$ s/div.  
0.2V/div.  
AC Mode

Before adjustment

Fig. 75

**5.10 Focus Servo Loop Gain Adjustment**

- Purpose: To adjust the focus servo loop gain to an optimum value
- Maladjustment symptoms: Poor playability, reduced resistance to vibration, focus closure fails readily

- |   |  |
|---|--|
| <ul style="list-style-type: none"> <li>● Measuring equipment/jigs</li> <li>● Measuring point</li> <li>● Test disc and setting</li> <li>● Adjustment position</li> </ul> | <ul style="list-style-type: none"> <li>● Oscillator, gain adjustment filter, dual meter milli-voltmeter</li> <li>● FEX, FEY</li> <li>● SONY TYPE 4 (or TYPE 3)    ● Normal mode</li> <li>● VR601-3 (FG)</li> </ul> |
|---|--|

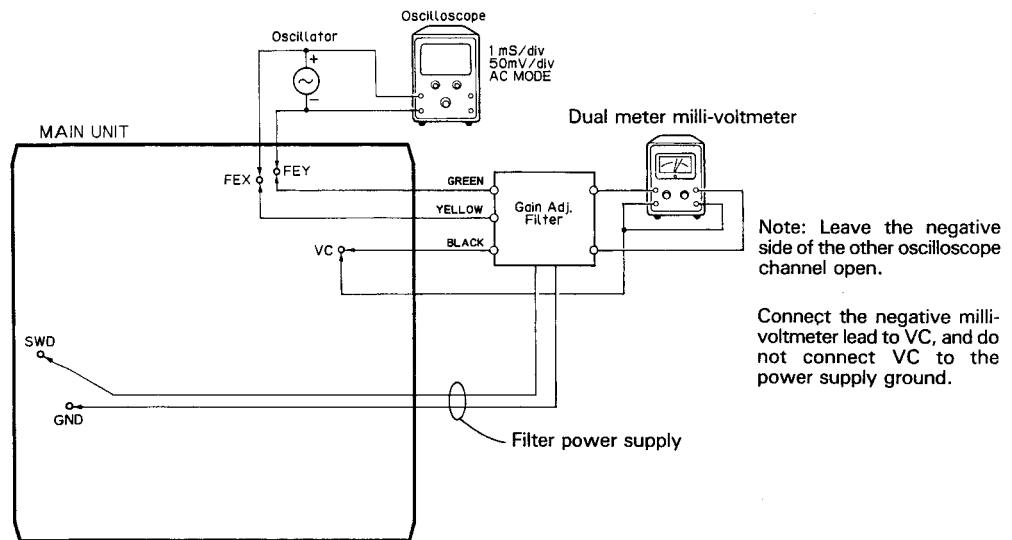

Fig. 76

**Adjustment Procedure**

1. After checking that the power is OFF, connect the gain adjustment filter and measuring equipment as shown in the above diagram.
2. Play tune TNO 12 in normal mode. (TYPE 3: TNO 14)
3. Set the oscillator to 1kHz, and observe the FEX/FEY output in the oscilloscope. Adjust the oscillator output to obtain a FEX/FEY output of 100mVp-p.
4. Adjust VR601-3 (FG) to obtain a milli-voltmeter difference of  $0 \pm 0.5\text{dB}$ .



### 5.11 Tracking Servo Loop Gain Adjustment

- Purpose: To adjust the tracking servo loop gain to an optimum value
- Maladjustment symptoms: Poor playability, reduced resistance to vibration

- |   |   |
|---|---|
| <ul style="list-style-type: none"> <li>● Measuring equipment/jigs</li> <li>● Measuring point</li> <li>● Test disc and setting</li> <li>● Adjustment position</li> </ul> | <ul style="list-style-type: none"> <li>● Oscillator, gain adjustment filter, dual meter milli-voltmeter</li> <li>● TEX, TEY</li> <li>● SONY TYPE 4 (or TYPE 3) • Normal mode</li> <li>● VR601-2 (TG)</li> </ul> |
|---|---|

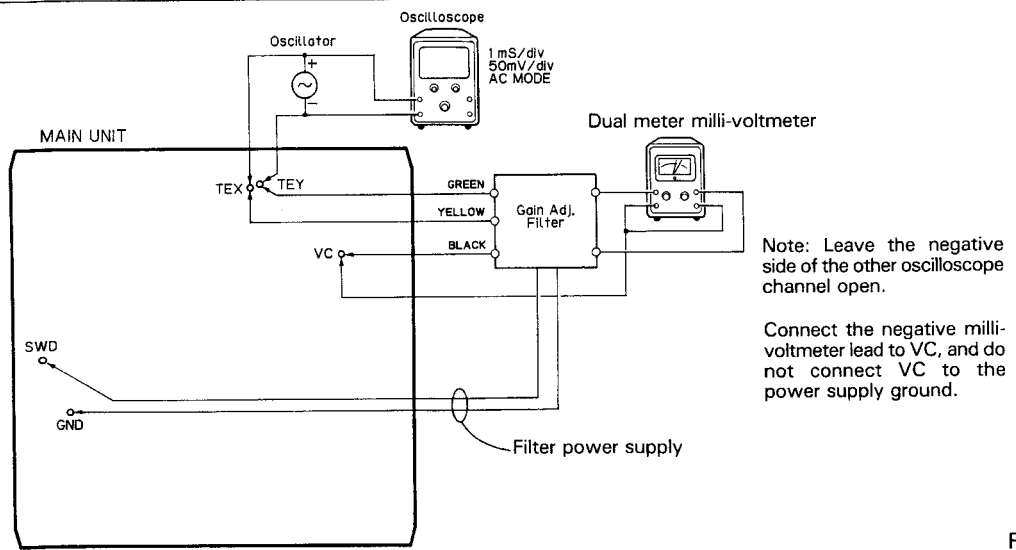

Fig. 77

#### Adjustment Procedure

1. After checking that the power is OFF, connect the gain adjustment filter and measuring equipment as shown in the above diagram.
2. Play tune TNO 12 in normal mode. (TYPE 3: TNO 14)
3. Set the oscillator to 1.4kHz, and observe the TEX/TEY output in the oscilloscope. Adjust the oscillator output to obtain a TEX/TEY output of 100mVp-p.
4. Adjust VR601-2 (TG) to obtain a milli-voltmeter difference of  $0 \pm 0.5\text{dB}$ .

**5.12 TE Offset Adjustment - II**

- Purpose: To adjust the electrical offset of the tracking servo to zero.
- Maladjustment symptoms: Search times too long, carriage run-away

- |  |   |   |
|--|---|---|
| <ul style="list-style-type: none"> <li>● Measuring equipment/<br/>jigs</li> <li>● Measuring point</li> <li>● Test disc and setting</li> <li>● Adjustment position</li> </ul> | <ul style="list-style-type: none"> <li>● DC voltmeter</li> <li>● TAO low-pass filter output</li> <li>● Empty magazine</li> <li>● VR351-2</li> </ul> | <ul style="list-style-type: none"> <li>● Test mode</li> </ul> |
|--|---|---|

**Adjustment Procedure**

Same as for TE offset adjustment - I, but with the DC voltage of the TAO LPF output adjusted to  $0 \pm 50\text{mV}$ .  
 The purpose of this additional adjustment is to correct any deviations generated when carrying out the tracking balance and tracking servo loop gain adjustments after completing TE offset adjustment - I.

### 5.13 Tracking Balance Adjustment - II

|   |   |
|---|---|
| <ul style="list-style-type: none"><li>● Purpose: To adjust the tracking servo offset to zero.</li><li>● Maladjustment symptoms: Search times too long, poor playability, carriage run-away</li></ul>  |   |
| <ul style="list-style-type: none"><li>● Measuring equipment/ jigs</li><li>● Measuring point</li><li>● Test disc and setting</li><li>● Adjustment position</li></ul>   | <ul style="list-style-type: none"><li>● Oscilloscope</li><li>● TEY low-pass filter output</li><li>● SONY TYPE 4 (or TYPE 3) • Test mode</li><li>● VR601-1</li></ul> |
| <p><b>Adjustment Procedure</b></p> <p>Steps 1 thru 5 same as tracking balance adjustment-I.</p> <p>6. Check that the level difference between the positive and negative amplitudes of the TEY signal is within 5% (See Fig. 52-54). If greater than 5%, adjust with VR601-1.</p> <p>7. If further adjustment was necessary in step 6, repeat TE off-set adjustment -II.</p> |   |

## • ICs and Transistors

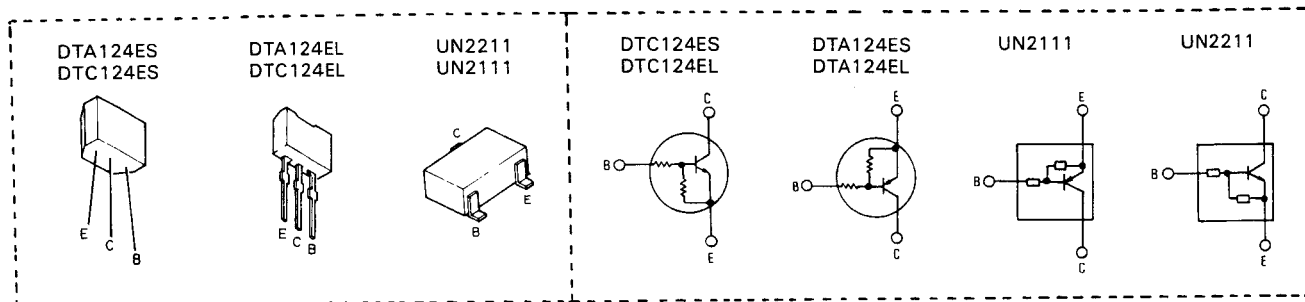

2SD1048

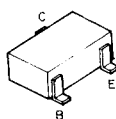

2SC3474

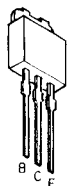

2SD1859  
2SB1243

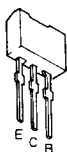

## Main Unit

IC651, 652: PA3021B

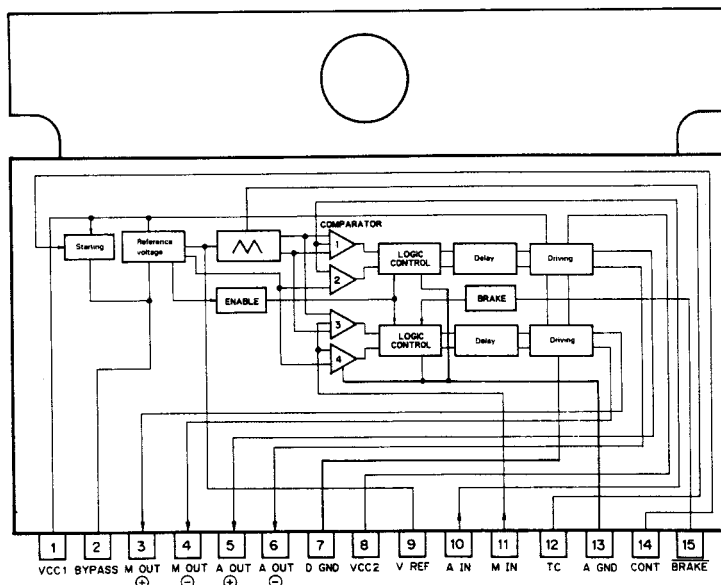

**PA3021B Terminal Functions**

PWM driver

| Pin No. | Pin name | I/O    | Function and operation   |
|---------|----------|--------|--|
| 1       | VCC1     |        | ACC power supply   |
| 2       | BYPASS   |        | IC reference voltage ripple filter condensor connection terminal             |
| 3       | MOUT+    | Output | Motor driver positive output terminal  |
| 4       | MOUT-    | Output | Motor driver negative output terminal  |
| 5       | AOUT+    | Output | Actuator driver positive output terminal                                     |
| 6       | AOUT-    | Output | Actuator driver negative output terminal                                     |
| 7       | DGND     |        | Power step GND terminal  |
| 8       | VCC2     |        | +5V power supply   |
| 9       | Vref     | Output | IC stabilizing supply output terminal  |
| 10      | AIN      | Input  | Actuator system analog signal input terminal                                 |
| 11      | MIN      | Input  | Motor system analog signal input terminal                                    |
| 12      | TC       |        | Chopping waveform condensor connection terminal                              |
| 13      | AGND     |        | Small signal system GND terminal   |
| 14      | CONT     | Input  | Circuit operation status, standby status selection terminal. Active "H".     |
| 15      | BRAKE    | Input  | Motor system operation, non-operation (STOP) selection terminal. Active "L". |

IC704: KHA221A

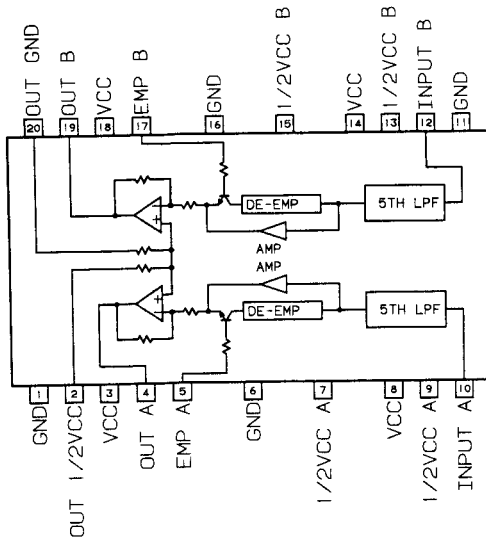

IC654, 655, 657, 658: M5218FP  
IC653:  $\mu$ PC358G

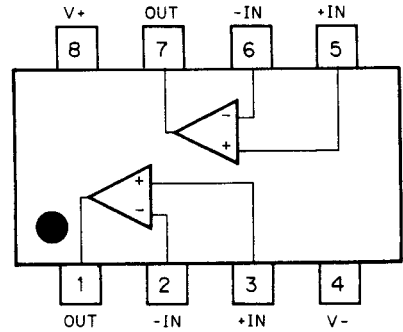

IC656: M5233FP

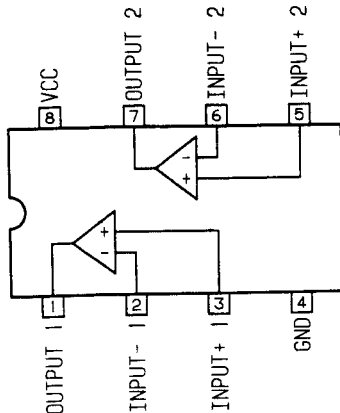

IC752: M51945AFP

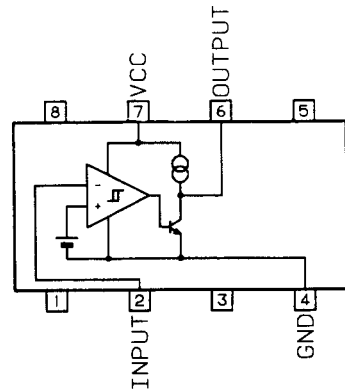

# CDX-M100

IC753: M51955AFP

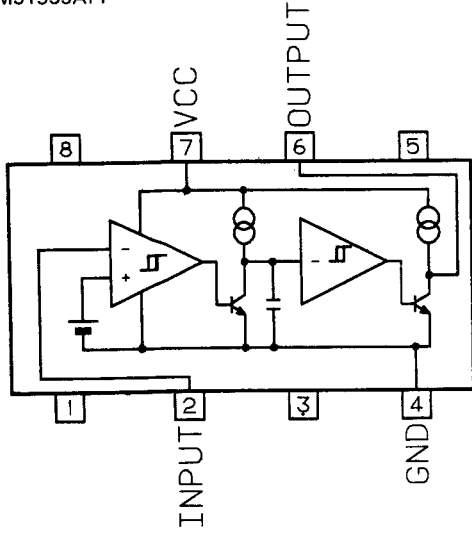

IC754: TC40H164F

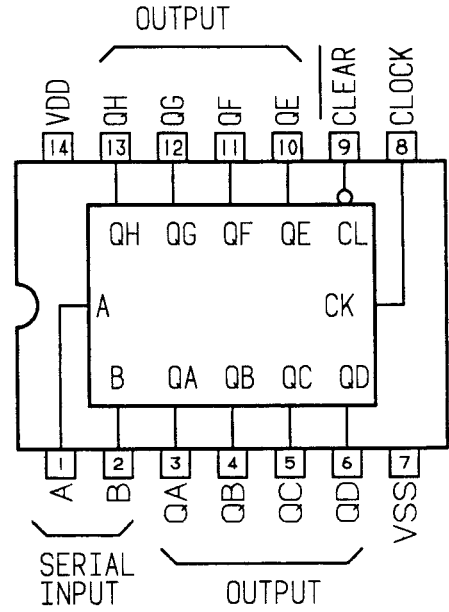

\*IC751: PD4121

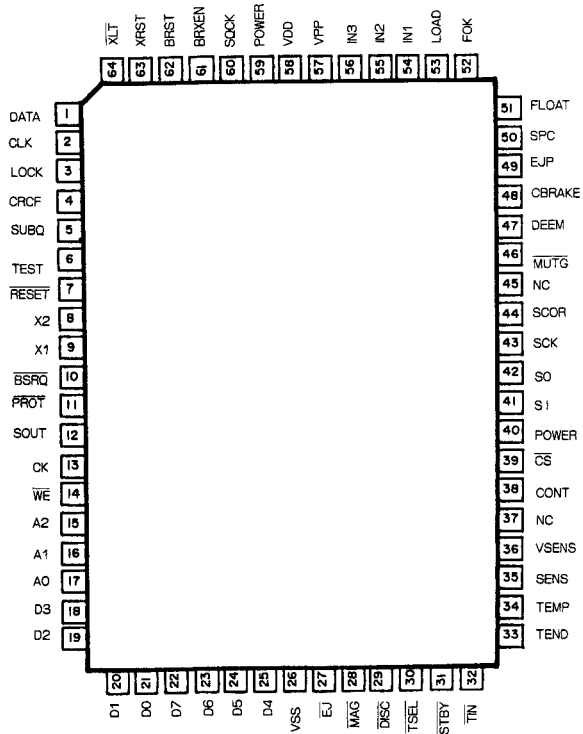

IC's marked by \* are MOS type.  
Be careful in handling them because they are very liable to be damaged by electrostatic induction.

## ● Pin Functions (PD4121)

| Pin No. | Pin Name | I/O          | Output Format | Function and Operation   |
|---------|----------|--------------|---------------|--|
| 1       | DATA     | Output       | C             | Serial data output   |
| 2       | CLK      | Output       | C             | Serial data clock  |
| 3       | LOCK     | Input        |               | Spindle lock monitor "H" = Lock  |
| 4       | CRCF     | Input        |               | CRC check result input "H" = CRC OK  |
| 5       | SUBQ     | Input        |               | Sub-code data input  |
| 6       | TEST     | Input        |               | Chip check mode/normal mode switching - "L" = Normal                                   |
| 7       | RESET    |              |               | Reset pin  |
| 8,9     | X2, X1   |              |               | Oscillator circuit   |
| 10      | BSRQ     | Output       | C             | Service request line   |
| 11      | PROT     | Output       | C             | RAM standby control - "L" = Standby  |
| 12      | SOUT     | Output       | C             | Address data   |
| 13      | CK       | Output       | C             | Address data shift clock   |
| 14      | WE       | Output       | C             | RAM writing  |
| 15-17   | A2-A0    | Output       | C             | Address line (RAM)   |
| 18-21   | D3-D0    | Input/Output | C             | Data line (RAM)  |
| 22-25   | D7-D4    | Input/Output | C             | Data line (RAM)  |
| 26      | VSS      |              |               | Ground   |
| 27      | EJ       | Input        |               | Magazine EJECT key "L" = Key depressed   |
| 28      | MAG      | Input        |               | Magazine lock switch "L" = Magazine detect   |
| 29      | DISC     | Input        |               | Disc detector photosensor "L" = Disc loaded  |
| 30      | TSEL     | Input        |               | Tray position detector photosensor   |
| 31      | STBY     | Input        |               | Elevator standby position detector switch - "L" = ON                                   |
| 32      | TIN      | Input        |               | Magazine tray housing switch - "L" = Tray housed                                       |
| 33      | TEND     | Input        |               | Disc clamped/Tray ejected  |
| 34      | TEMP     | Input        |               | High temperature detector  |
| 35      | SENS     | Input        |               | CD LSI internal status monitor input   |
| 36      | VSNS     | Input        |               | Back-up sensor - "H" = Back-up ON  |
| 37      | NC       | Output       |               |  |
| 38      | CONT     | Output       | C             | PWM driver ON/OFF - "H" = ON   |
| 39      | CS       | Output       | C             | RAM chip select - "L" = RAM ACTIVE   |
| 40      | POWER    | Output       | C             | DD converter ON/OFF - "H" = ON   |
| 41      | SI       | Input        |               | Data line  |
| 42      | SO       | Output       | C             | Data line  |
| 43      | SCK      | Input/Output | C             | Synchronizing shift clock  |
| 44      | SCOR     | Input        |               | Sub-code synchronization input - T = 13.3msec during playback                          |
| 45      | NC       | Output       |               |  |
| 46      | MUTG     | Output       | NM            | Muting output - "L" = Mute ON  |
| 47      | DEEM     | Output       | NM            | Emphasis selector output - "H" = Emphasis ON   |
| 48      | CBRAKE   | Output       | NM            | PWM driver brake control - "L" = Brake ON  |
| 49      | EJP      | Input        |               | Eject position switch - "L" = ON   |
| 50      | SPC      | Input        |               | Spindle motor rpm indicator - "L" = Low speed  |
| 51      | FLOAT    | Input        |               | Mechanical float switch - "L" = Mechanism fixed  |
| 52      | FOK      | Input        |               | Indication that focus is closed and RF input is active<br>"H" = RF active, "L" = No RF |
| 53      | LOAD     | Output       | NM            | Loading power supply ON/OFF  |
| 54      | IN1      | Output       | NM            | Motor driver control pin   |

# CDX-M100

| Pin No. | Pin Name                | I/O          | Output Format | Function and Operation   |
|---------|-------------------------|--------------|---------------|--------------------------|
| 55      | IN2                     | Output       | NM            | Motor reverse            |
| 56      | IN3                     | Output       | NM            | Motor forward            |
| 57      | VPP                     |              |               | Write power supply       |
| 58      | VDD                     |              |               | +5V                      |
| 59      | POWER                   | Output       | C             | Power supply control     |
| 60      | SQCK                    | Output       | C             | Sub-code clock           |
| 61      | BRXEN                   | Input/Output | C             | Line BUSY signal line    |
| 62      | BRST                    | Input        |               | Reset input              |
| 63      | XRST                    | Output       | C             | CD LSI reset pin         |
| 64      | $\overline{\text{XLT}}$ | Output       | C             | Serial data latch output |

| Output format | Meaning                                  |
|---------------|--|
| C             | CMOS output                              |
| NM            | Neutral resistivity N channel open drain |

\*IC351: CXA1081M

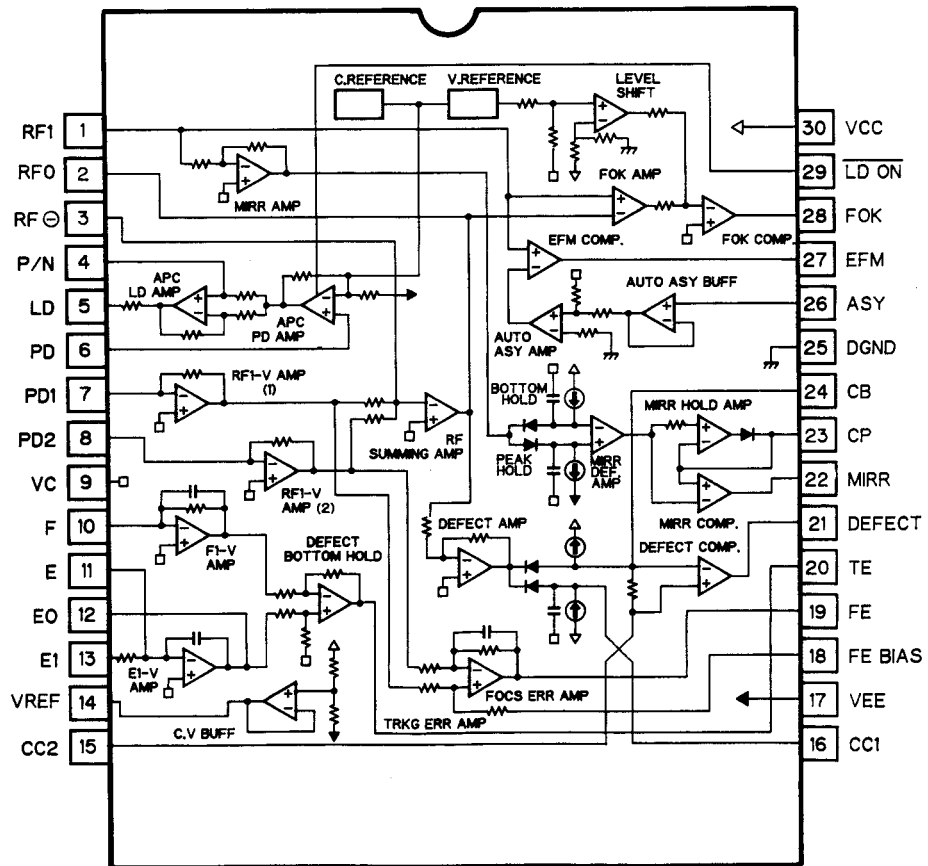



## ● Pin Functions (CXA1081M)

| Pin No. | Pin Name | I/O    | Function and Operation  |
|---------|----------|--------|---|
| 1       | RFI      | Input  | Input of capacitance-coupled RF summing amplifier output                                      |
| 2       | RFO      | Output | RF summing amplifier output pin - eye pattern check point                                     |
| 3       | RF-      | Input  | RF summing amplifier feedback input pin   |
| 4       | P/N      | Input  | Laser diode P-sub/N-sub selector pin  |
| 5       | LD       | Output | APC LD amplifier output pin   |
| 6       | PD       | Input  | APC PD amplifier input pin  |
| 7       | PD1      | Input  | RF I-V amplifier (1) inverter input pin - connected to photodiode A + C pin for current input |
| 8       | PD2      | Input  | RF I-V amplifier (2) inverter input pin - connected to photodiode B + D pin for current input |
| 9       | VC       |        | Connected to VR   |
| 10      | F        | Input  | I-V amplifier inverter input pin - connected to photodiode for current input                  |
| 11      | E        | Input  | I-V amplifier inverter input pin - connected to photodiode for current input                  |
| 12      | EO       | Output | E I-V amplifier output pin  |
| 13      | EI       | Input  | E I-V amplifier feedback input pin for E I-V amplifier gain adjustment                        |
| 14      | VR       | Output | $(V_{CC} + V_{EE})/2$ DC voltage output pin   |
| 15      | CC2      | Input  | Input of capacitance-coupled DEFECT bottom hold output  |
| 16      | CC1      | Output | DEFECT bottom hold output pin   |
| 17      | VEE      |        | Ground connection   |
| 18      | FE BIAS  | Input  | Focus error amplifier non-inverting bias pin<br>Used in focus error amplifier CMR adjustment  |
| 19      | FE       | Output | Focus error amplifier output pin  |
| 20      | TE       | Output | Tracking error amplifier output pin   |
| 21      | DEFECT   | Output | DEFECT comparator output pin  |
| 22      | MIRR     | Output | MIRR comparator output pin  |
| 23      | CP       | Input  | MIRR hold capacitor connector pin - MIRR comparator non-inverting input pin                   |
| 24      | CB       | Input  | DEFECT bottom hold capacitor connector pin  |
| 25      | DGND     |        | Ground connection   |
| 26      | ASY      | Input  | Auto asymmetry control input pin  |
| 27      | EFM      | Output | EFM comparator output pin   |
| 28      | FOK      | Output | Focus OK comparator output pin  |
| 29      | LDON     | Input  | Laser diode ON/OFF switching  |
| 30      | VCC      |        | Positive power supply pin   |

# CDX-M100

\*IC701: CXD1135Q

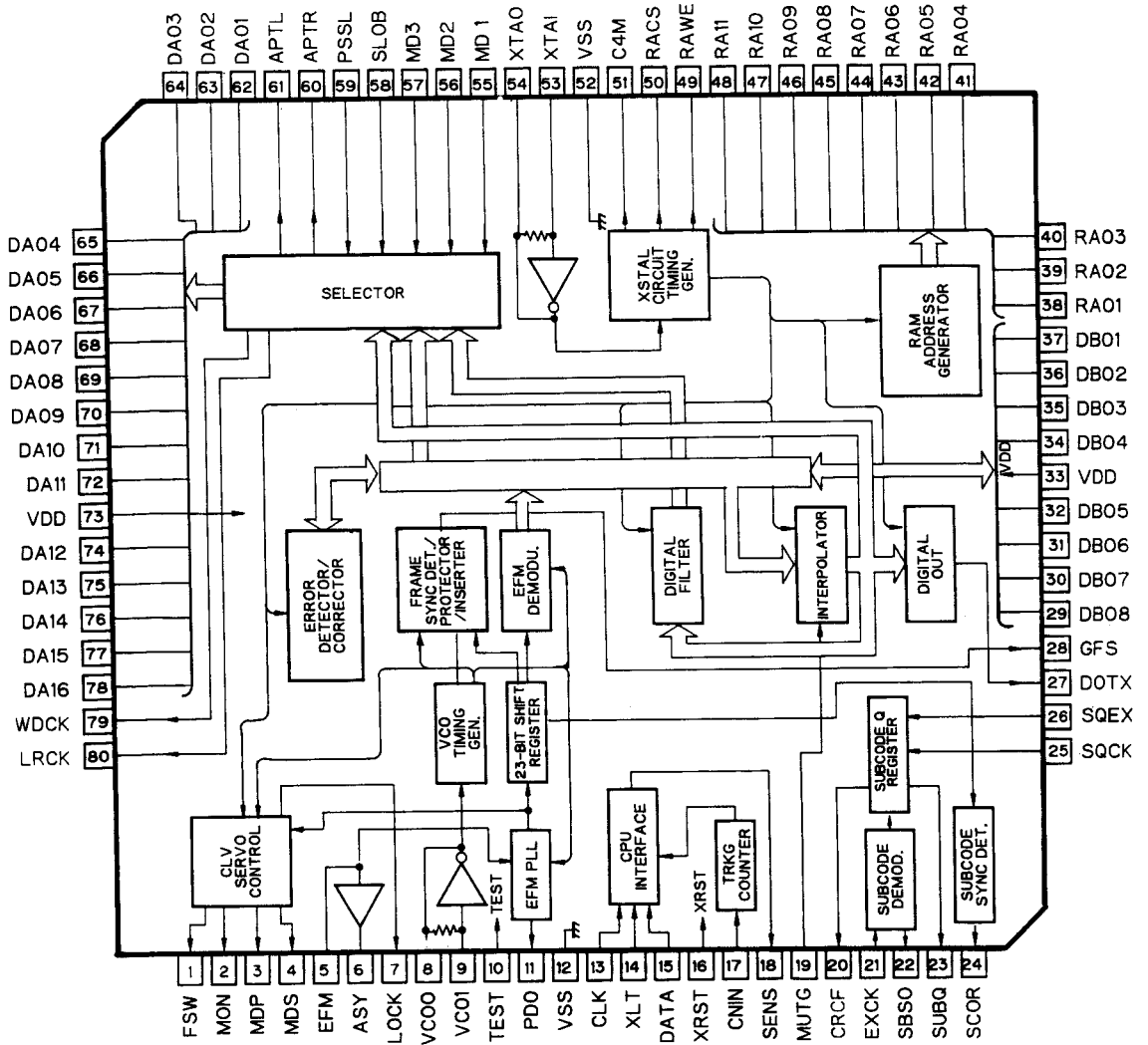

● Pin Functions (CXD1135Q)

| Pin No. | Pin Name        | I/O          | Function and Operation   |
|---------|-----------------|--------------|--|
| 1       | FSW             | Output       | Spindle motor output filter time constant selector output  |
| 2       | MON             | Output       | Spindle motor ON/OFF control output  |
| 3       | MDP             | Output       | Spindle motor drive output - "rough" control in CLV-S mode, and phase control in CLV-P mode                  |
| 4       | MDS             | Output       | Spindle motor drive output - speed control in CLV-P mode   |
| 5       | EFM             | Input        | EFM signal input from RF amplifier   |
| 6       | ASY             | Output       | EFM signal slice level control output  |
| 7       | LOCK            | Output       | Sampling of GFS signal by WFCK/16 - "H" output if "H", "L" output if "L" detected eight times in succession  |
| 8       | VCOO            | Output       | VCO output - $f = 8.6436\text{MHz}$ when EFM signal is locked  |
| 9       | VCOI            | Input        | VCO input  |
| 10      | TEST            | Input        | (0V)   |
| 11      | PDO             | Output       | EFM signal and VCO/2 phase comparison output   |
| 12      | V <sub>SS</sub> | —            | Ground (0V)  |
| 13      | CLK             | Input        | Serial data transfer clock input from CPU - data latched by clock leading edge                               |
| 14      | XLT             | Input        | Latch input from CPU - 8-bit shift register data (serial data from CPU) is latched in each register.         |
| 15      | DATA            | Input        | Serial data input from CPU   |
| 16      | XRST            | Input        | System reset signal input - reset when "L"   |
| 17      | CNIN            | Input        | Tracking pulse input   |
| 18      | SENS            | Output       | Output of internal status according to address   |
| 19      | MUTG            | Input        | Muting input - when ATTM of internal register A is "L", MUTG "L" denotes normal status, and "H" muted status |
| 20      | CRCF            | Output       | Sub-code Q CRC check result output   |
| 21      | EXCK            | Input        | Clock input for sub-code serial output   |
| 22      | SBSO            | Output       | Sub-code serial output   |
| 23      | SUBQ            | Output       | Sub-code Q output  |
| 24      | SCOR            | Output       | Sub-code synchronizing S0 + S1 output  |
| 25      | SQCK            | Input/Output | Sub-code Q read clock  |
| 26      | SQEX            | Input        | SQCK selector input  |
| 27      | DOTX            | Output       | Digital out output (WFCK output)   |
| 28      | GFS             | Output       | Frame synchronizing lock status indicator output   |
| 29      | DB08            | Input/Output | External RAM data pin - DATA8 (MSB)  |
| 30      | DB07            | Input/Output | External RAM data pin - DATA7  |
| 31      | DB06            | Input/Output | External RAM data pin - DATA6  |
| 32      | DB05            | Input/Output | External RAM data pin - DATA5  |
| 33      | V <sub>DD</sub> | —            | Power supply (+5V)   |
| 34      | DB04            | Input/Output | External RAM data pin - DATA4  |
| 35      | DB03            | Input/Output | External RAM data pin - DATA3  |

| Pin No. | Pin Name        | I/O          | Function and Operation  |
|---------|-----------------|--------------|---|
| 36      | DB02            | Input/Output | External RAM data pin - DATA2   |
| 37      | DB01            | Input/Output | External RAM data pin - DATA1 (LSB)   |
| 38      | RA01            | Output       | External RAM address output - ADDR01 (LSB)  |
| 39      | RA02            | Output       | External RAM address output - ADDR02  |
| 40      | RA03            | Output       | External RAM address output - ADDR03  |
| 41      | RA04            | Output       | External RAM address output - ADDR04  |
| 42      | RA05            | Output       | External RAM address output - ADDR05  |
| 43      | RA06            | Output       | External RAM address output - ADDR06  |
| 44      | RA07            | Output       | External RAM address output - ADDR07  |
| 45      | RA08            | Output       | External RAM address output - ADDR08  |
| 46      | RA09            | Output       | External RAM address output - ADDR09  |
| 47      | RA10            | Output       | External RAM address output - ADDR010   |
| 48      | RA11            | Output       | External RAM address output - ADDR011 (MSB)   |
| 49      | RAWE            | Output       | External RAM write enable signal output (active "L")  |
| 50      | RACS            | Output       | External RAM chip select signal output (active "L")   |
| 51      | C4M             | Output       | X'tal frequency division output (f = 4.2336MHz)   |
| 52      | V <sub>SS</sub> | —            | Ground (0V)   |
| 53      | XTAI            | Input        | Crystal oscillator input (f = 8.4672MHz)  |
| 54      | XTAO            | Output       | Crystal oscillator output (f = 8.4672MHz)   |
| 55      | MD1             | Input        | Mode selector input 1   |
| 56      | MD2             | Input        | Mode selector input 2   |
| 57      | MD3             | Input        | Mode selector input 3   |
| 58      | SLOB            | Input        | Audio data output code selector input - 2's complement output if "L", offset binary output if "H" |
| 59      | PSSL            | Input        | Audio data output mode selector input - serial output if "L", parallel output if "H"              |
| 60      | APTR            | Output       | Aperture correction control output - "H" when right channel                                       |
| 61      | APTL            | Output       | Aperture correction control output - "L" when left channel  |
| 62      | DA01            | Output       | C1F1 output   |
| 63      | DA02            | Output       | C1F2 output   |
| 64      | DA03            | Output       | C2F1 output   |
| 65      | DA04            | Output       | C2F2 output   |
| 66      | DA05            | Output       | C2FL output   |
| 67      | DA06            | Output       | C2PO output   |
| 68      | DA07            | Output       | RFCK output   |
| 69      | DA08            | Output       | WFCK output   |
| 70      | DA09            | Output       | $\overline{\text{PLCK}}$ output   |
| 71      | DA10            | Output       | UGFS output   |
| 72      | DA11            | Output       | GTOP output   |

| Pin No. | Pin Name        | I/O    | Function and Operation          |
|---------|-----------------|--------|---------------------------------|
| 73      | V <sub>DD</sub> | —      | Power supply (+ 5V)             |
| 74      | DA12            | Output | RAOV output                     |
| 75      | DA13            | Output | C4LR output                     |
| 76      | DA14            | Output | $\overline{\text{C210}}$ output |
| 77      | DA15            | Output | C210 output                     |
| 78      | DA16            | Output | DATA output                     |
| 79      | WDCK            | Output | Strobe signal output (176.4kHz) |
| 80      | LRCK            | Output | Strobe signal output (88.2kHz)  |

Note:

- C1F1:  C1 decoding error correction status monitor output
- C1F2:  C1 decoding error correction status monitor output
- C2F1:  C2 decoding error correction status monitor output
- C2F2:  C2 decoding error correction status monitor output
- C2FL:  Corrected status output - "H" if C2 system currently being corrected cannot be corrected
- C2PO:  C2 pointer indication output - synchronized with audio data output
- RFCK:  Read frame clock output - crystal oscillator 7.35kHz
- WFCK:  Write frame clock output -  $f = 7.35\text{kHz}$  when crystal oscillator is locked
- $\overline{\text{PLCK}}$ :  VCO/2 output -  $f = 4.3218\text{MHz}$  when EFM signal is locked
- UGFS:  Unprotected frame synchronizing pattern output
- GTOP:  Frame synchronization protection status indicator output
- RAOV:   $\pm 4$  frame jitter absorption RAM overflow and underflow indicator output
- C4LR:  Strobe signal - 176.4kHz
- $\overline{\text{C210}}$ :  C210 inverting output
- C210:  Bit clock output - 2.1168MHz
- DATA:  Audio signal serial data output

\*IC601: CXA1082AQ

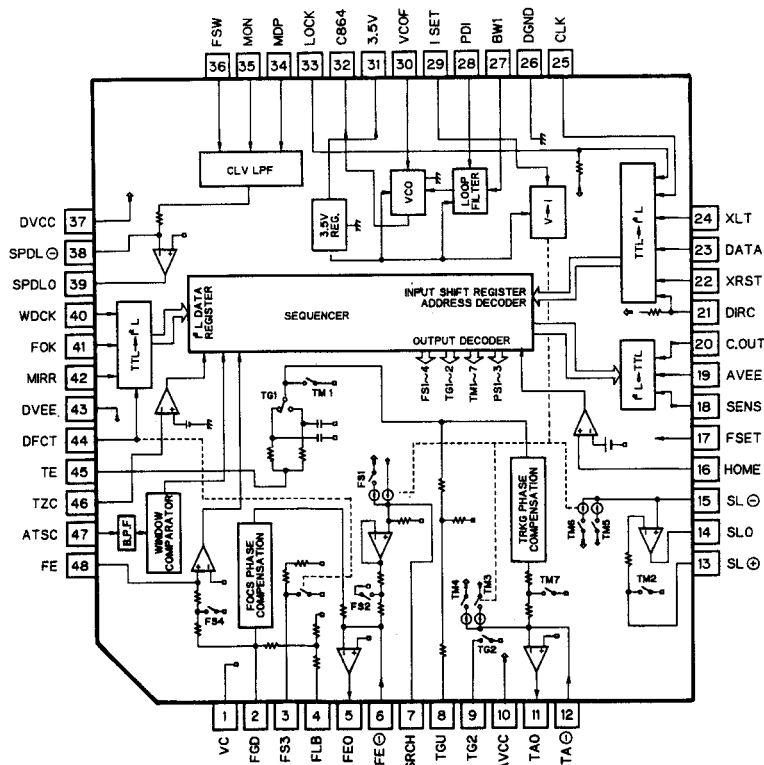

**● Pin Functions (CXA1082AQ)**

| Pin No. | Pin Name | I/O    | Function and Operation  |
|---------|----------|--------|---|
| 1       | VC       |        | Servo reference voltage input pin   |
| 2       | FGD      |        | Connect to pin 3 to switch focus servo OFF when defect occurs                             |
| 3       | FS3      |        | Internal DFCT switch closed when pin 44 is high   |
| 4       | FLB      |        | Focus servo low region boost external time constant pin                                   |
| 5       | FEO      | Output | Focus drive output - connect to low-end equalizer   |
| 6       | FE-      | Input  | Focus amplifier inverter input pin  |
| 7       | SRCH     |        | Focus search waveform generation external time constant connector pin                     |
| 8       | TGU      | Output | Tracking low-end equalizer connection output pin  |
| 9       | TG2      |        | Pin 7 discharge switch for starting focus search from lens center                         |
| 10      | AVCC     |        | + 5V connection   |
| 11      | TAO      | Output | Tracking drive output   |
| 12      | TA-      | Input  | Tracking amplifier inverter input pin   |
| 13      | SL+      | Input  | Sled amplifier non-inverting input pin  |
| 14      | SLO      | Output | Sled drive output   |
| 15      | SL-      | Input  | Sled amplifier inverter input pin   |
| 16      | HOME     | Input  | Sled home position detector switch input pin  |
| 17      | FSET     |        | Focus/tracking phase compensation peak and CLV low-pass filter $f_0$ setting pin          |
| 18      | SENS     | Output | Output of FZC, AS, TZC, SSTOP, and $\overline{\text{BUSY}}$ depending on command from CPU |
| 19      | AVEE     |        | AGND connection   |
| 20      | COUT     | Output | Track counter signal output   |
| 21      | DIRC     |        | Not used  |
| 22      | XRST     | Input  | Reset input pin - reset when "L"  |
| 23      | DATA     | Input  | Serial data input from CPU  |
| 24      | XLT      | Input  | Latch input from CPU  |
| 25      | CLK      | Input  | Serial data transfer clock input from CPU   |
| 26      | DGND     |        | DGND connection   |
| 27      | BW1      |        | Loop filter external time constant pin  |
| 28      | PDI      | Input  | Input of CXD1135 phase comparator output PDO  |
| 29      | ISET     |        | Current which determines focus search, track jump, and sled kick height                   |
| 30      | VCOF     |        | VCO free-running frequency more or less inversely   |
| 31      | 3.5V     | Output | Proportional to resistance value between pins 30 and 31                                   |
| 32      | C864     | Output | 8.64MHz VCO output pin  |
| 33      | LOCK     |        | Not used  |
| 34      | MDP      |        | Connect to MDP pin of CXD1135   |
| 35      | MON      |        | Connect to MON pin of CXD1135   |
| 36      | FSW      |        | CLV servo error signal low-pass filter external time constant pin                         |
| 37      | DVCC     |        | + 5V connection   |
| 38      | SPDL-    | Input  | Spindle drive amplifier inverter input pin  |

| Pin No. | Pin Name | I/O    | Function and Operation  |
|---------|----------|--------|---|
| 39      | SPDLO    | Output | Spindle drive output  |
| 40      | WDCK     | Input  | Auto-sequence clock input 176.4kHz  |
| 41      | FOK      | Input  | FOK signal input pin  |
| 42      | MIRR     | Input  | Mirror signal input pin   |
| 43      | DVEE     |        | DGND connection   |
| 44      | DFCT     | Input  | DEFECT signal input pin - defect countermeasure circuit activated when this input is high |
| 45      | TE       | Input  | Tracking error signal input pin   |
| 46      | TZC      | Input  | Tracking zero-cross comparator input pin  |
| 47      | ATSC     | Input  | Tracking lens offset detector window comparator input pin                                 |
| 48      | FE       | Input  | Focus error signal input pin  |

\*IC703:  $\mu$ PD6355G

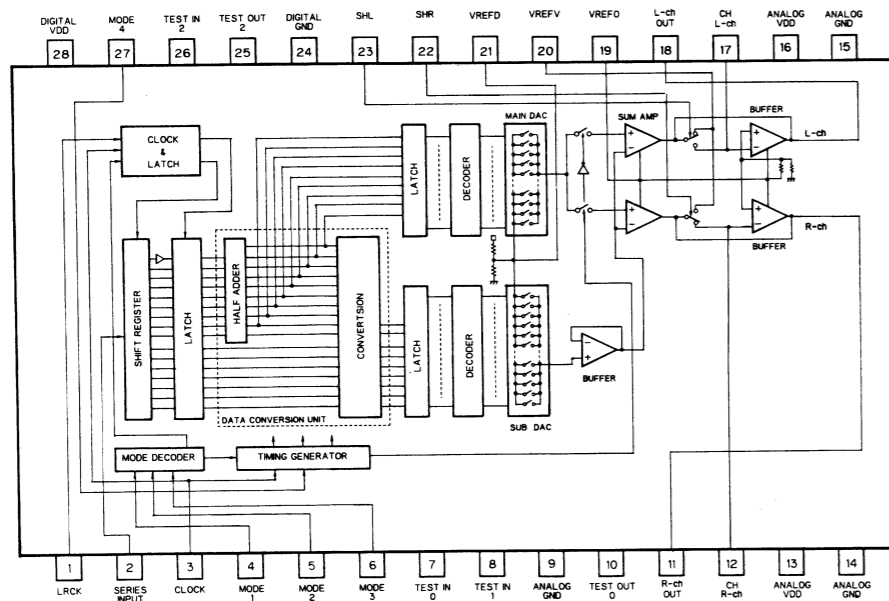

● Pin Functions ( $\mu$ PD6355G)

| Pin No. | Pin Name                          | I/O    | Function and Operation  |
|---------|-----------------------------------|--------|---|
| 1       | LRCK                              | Input  | Input data left/right discriminator signal input pin<br>"L" = Left, "H" = Right |
| 2       | SI                                | Input  | Serial data input pin   |
| 3       | CLK                               | Input  | Serial input data read clock input pin  |
| 4-6     | M1-M3                             | Input  | Input data mode selector pin  |
| 7,8     | TI <sub>0</sub> , TI <sub>1</sub> | Input  | Test pins   |
| 9       | A·GND                             |        | Analog stage ground pin   |
| 10      | TO0                               | Output | Test pin  |
| 11      | ROUT                              | Output | Right channel analog signal output pin  |
| 12      | CHR                               | Output | Right channel analog signal sample hold capacitor pin                           |
| 13      | A·VDD                             |        | Analog stage power supply pin   |

| Pin No. | Pin Name | I/O    | Function and Operation   |
|---------|----------|--------|--|
| 14,15   | A·GND    |        | Analog stage ground pins   |
| 16      | A·VDD    |        | Analog stage power supply pin  |
| 17      | CHL      | Output | Left channel analog signal sample hold capacitor pin   |
| 18      | LOUT     | Output | Left channel analog signal output pin  |
| 19      | VREFO    |        | Operation amplifier reference connection   |
| 20      | VREFV    |        | Connection to AGND via capacitor   |
| 21      | VREFD    |        | Connection to resistance ladder  |
| 22      | SHR      | Input  | Right channel analog output sample hold timing signal<br>Active high   |
| 23      | SHL      | Input  | Left channel analog output sample hold timing signal<br>Active high  |
| 24      | D·GND    |        | Logic stage ground pin   |
| 25      | TO2      | Output | Test pin   |
| 26      | TI2      | Input  | Test pin   |
| 27      | M4       | Input  | Internal logic clock selection which determines whether input from CLK pin is to be divided or not<br>"H": No division, "L": Divide by 2 |
| 28      | D·VDD    |        | Logic stage power supply pin   |

\*IC702, 755: CXK5816M-15L

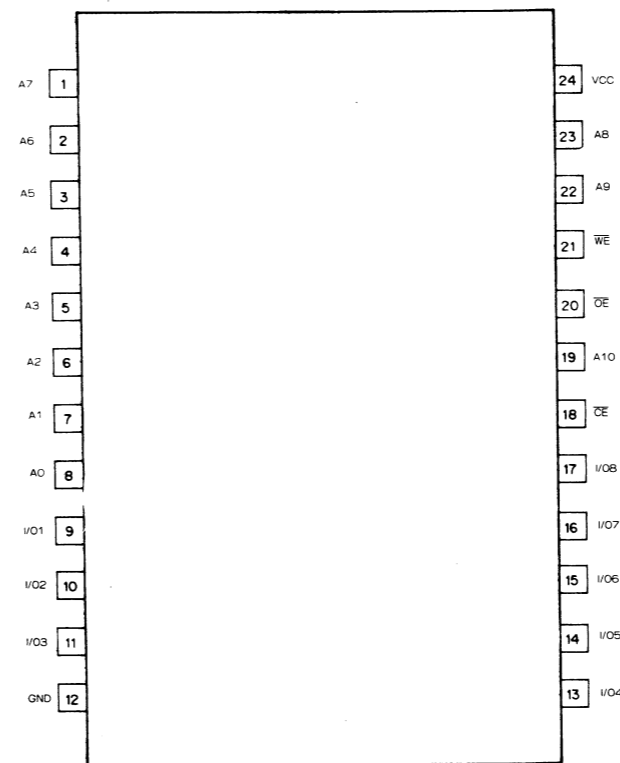

Driver P.C. Bo

IC801: BA6238

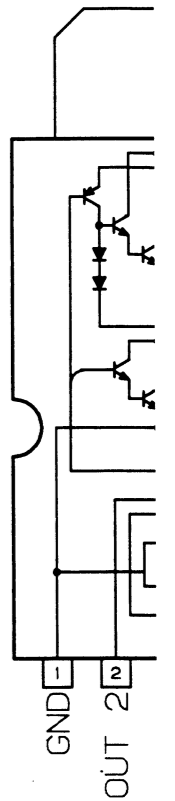

IC803: BA6209

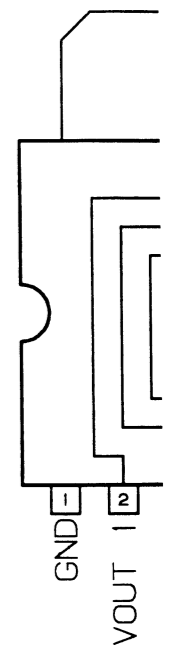

Driver P.C. Board

IC801: BA6238A

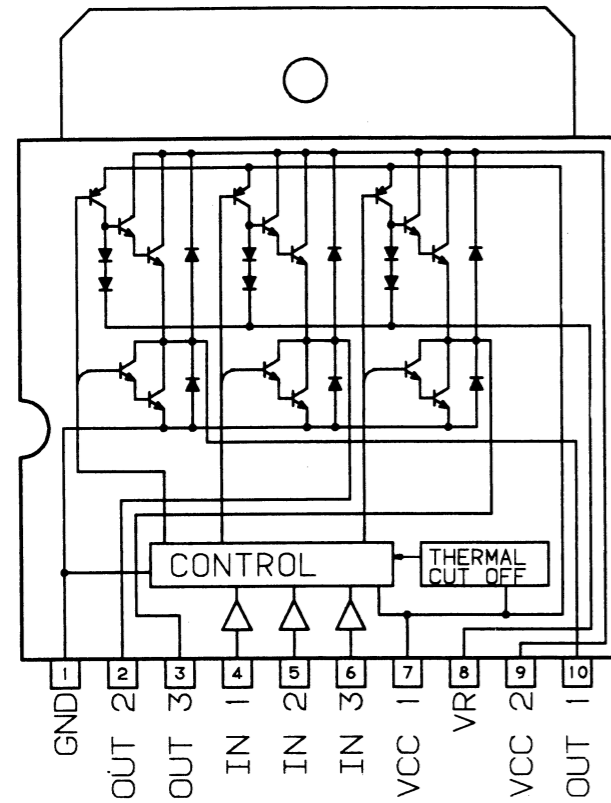

IC802: TC4025B

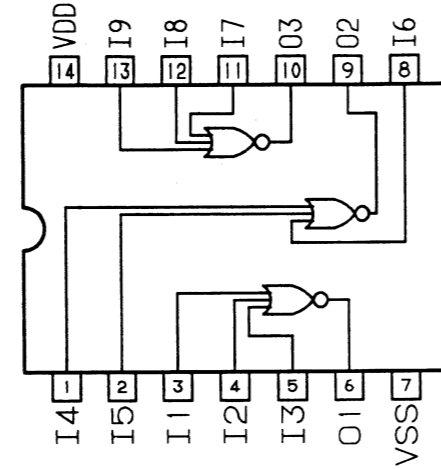

IC803: BA6209

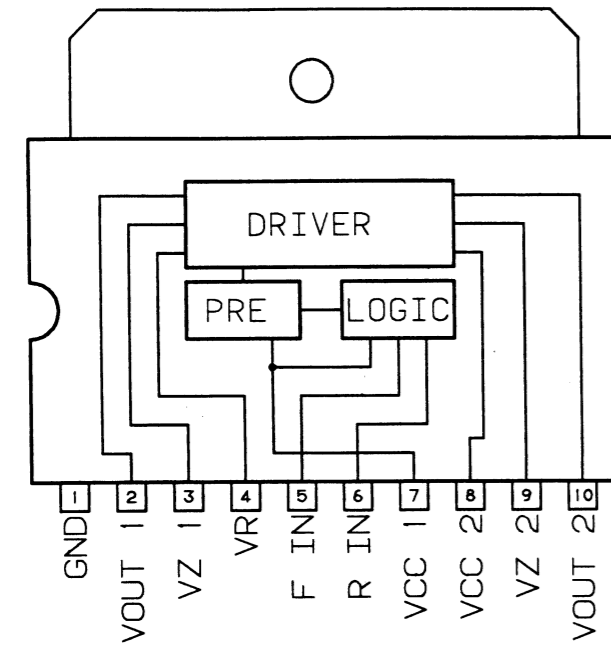

● Truth Table (BA6209)

| FIN (Pin 5) | RIN (pin 6) | VOUT1 (pin 2) | VOUT2 (pin 10) |
|-------------|-------------|---------------|----------------|
| H           | H           | L             | L              |
| L           | H           | L             | H              |
| H           | L           | H             | L              |
| L           | L           | L             | L              |

Note: Input level H more than 2.0V, and input level L less than 0.7V

● Circuit Diagram Symbols

| Symbol  | Function  | Symbol | Function  |
|---------|---|--------|---|
| A       | 1/4 division detector output used in detection of RF and focus signal           | FEO2   | Focus 2 (IC655 pin no.7)  |
| ACC     | 14.4V   | FLOAT  | Carriage mechanism play position detector signal                            |
| AGND    | Analog ground   | HOME   | Home position detector signal (pick-up at home position when "L")           |
| ASY     | Asymmetry   | IN1    | Motor control signal 1  |
| ATSC    | Anti-shock (carriage motor control during playback)                             | IN2    | Motor control signal 2  |
| B       | 1/4 division detector output used in detection of RF and focus signal           | IN3    | Motor control signal 3  |
| BATT    | 14.4V (Constant power supply)   | ISETY  | ISET resistance pin (IC601 pin no.31)                                       |
| BDATA   | Bus data signal   | LAMP   | Photo-interrupter drive signal  |
| BRST    | Bus reset signal  | LD     | Laser diode   |
| BRXEN   | Bus line busy signal  | LOAD   | Magazine loading power supply ON/OFF signal                                 |
| BCK     | Bus synchronizing shift clock   | MON    | Motor ON (spindle forward or reverse when "H")                              |
| BSRQ    | Bus service request line  | MAG    | Magazine detector signal  |
| BYPASS1 | Bypass 1 (non-drive enabled by connecting to ground during PWM IC651 operation) | MD     | Monitor diode   |
| BYPASS2 | Bypass 2 (non-drive enabled by connecting to ground during PWM IC652 operation) | MUTG   | Mute signal (muting ON when "L")  |
| C       | 1/4 division detector output used in detection of RF and focus signal           | POWER  | Power supply control signal   |
| CBRAKE  | PWM driver brake control signal (brake on when "L")                             | REG5   | + 5V  |
| CLAMP+  | Clamp motor drive signals   | SLO    | Carriage output signal (IC601 pin no.14)                                    |
| CLAMP-  |   | SM+    | Spindle motor drive signals (PWM OUT)                                       |
| CM+     | Carriage motor drive signal (PWM OUT)   | SM-    |   |
| CM-     |   | SPC    | Spindle motor rpm detector signal (low speed when "L", IC656 pin nos.1 & 7) |
| CONT    | PWM driver ON/OFF signal (ON when "H")  | SPCO   | Spindle brake (spindle brake when "H", IC751 pin no. 59)                    |
| D       | 1/4 division detector output used in detection of RF and focus signal           | SPDLO  | Spindle motor error signal (IC601 pin no.39)                                |
| DEEM    | Emphasis selector switch (emphasis ON when "H")                                 | SPTAO  | Tracking side path signal output  |
| DFCT    | DEFECT signal ("H" when defect)   | SMIN   | Spindle motor drive PWM input signal  |
| DGND    | Digital ground  | STBY   | Standby position detector signal  |
| DISC    | Disc presence detector signal   | TA+    | Tracking actuator drive signals (PWM OUT)                                   |
| E       | Tracking signal start detector  | TA-    |   |
| EFM     | 8-14 modulation   | TAIN   | Tracking actuator drive PWM input signal                                    |
| EJ      | Eject key   | TEND   | Mechanism clamped switching line  |
| EJP     | Magazine position detector signal (eject position when "L")                     | TGU    | Tracking side path input  |
| ELV+    | Elevation motor drive signals   | TIN    | Tray position detector signal (tray housed when "L")                        |
| ELV-    |   | TIG    | Switch ground   |
| END     | Carriage mechanism END position detector signal                                 | TOG    | Switch ground   |
| F       | Tracking signal end detector  | TOUT   | Tray position detector signal (tray ejected when "H")                       |
| FA+     | Focus actuator drive signal (PWM OUT)   | TRAY+  | Tray motor drive signals  |
| FA-     |   | TRAY-  |   |
| FAIN    | Focus drive PWM input signal  | TSEL   | Magazine position detector signal   |
| FEO     | Focus signal output (IC601, CXA1082AQ pin no.5)                                 | TZC    | T.E zero-cross signal   |
|         |   | VC     | Signal reference voltage (2.5V)   |
|         |   | VREF   | Signal reference voltage buffer output (2.5V)                               |



6. SCHEMATIC CIRCUIT DIAGRAM

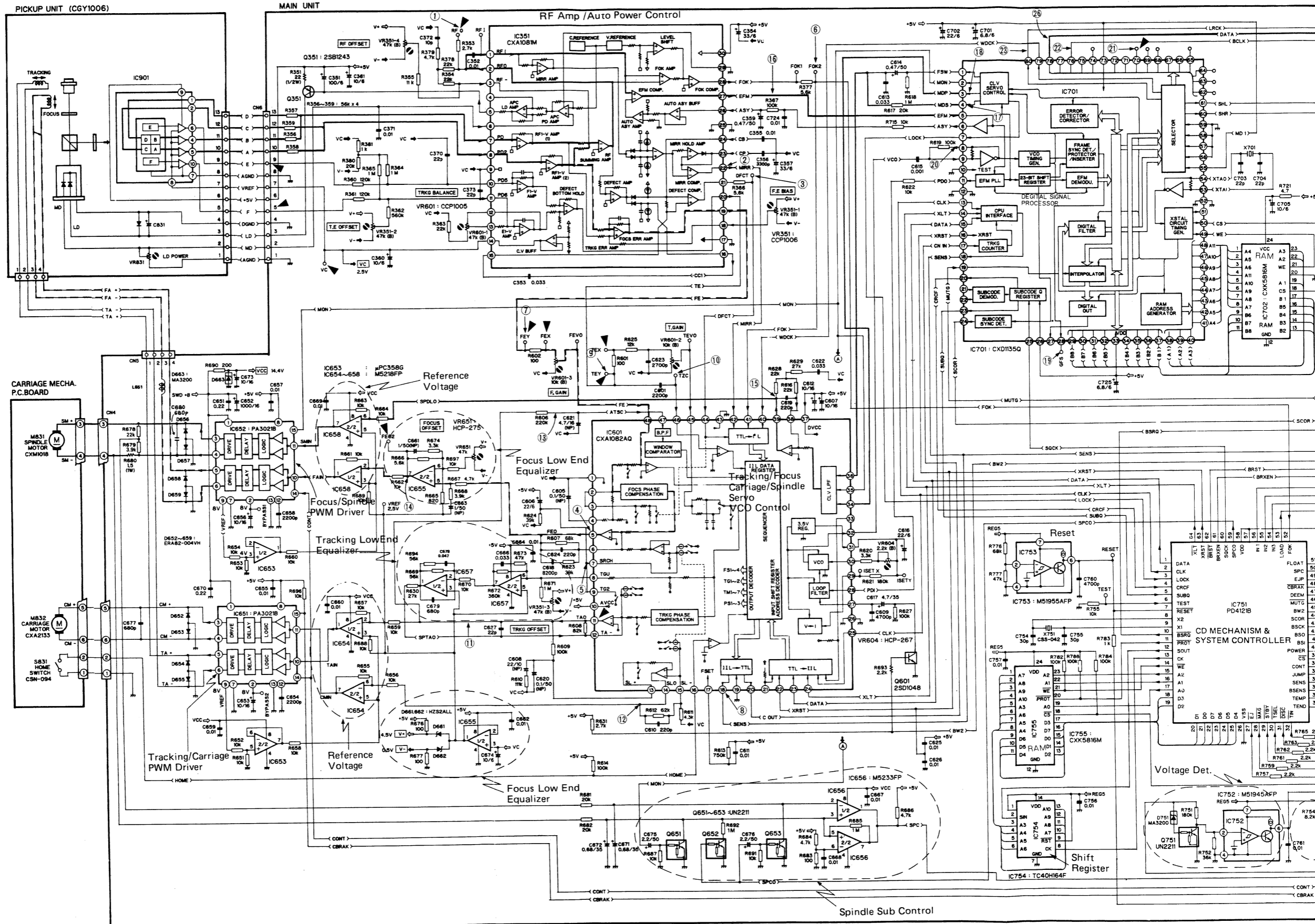

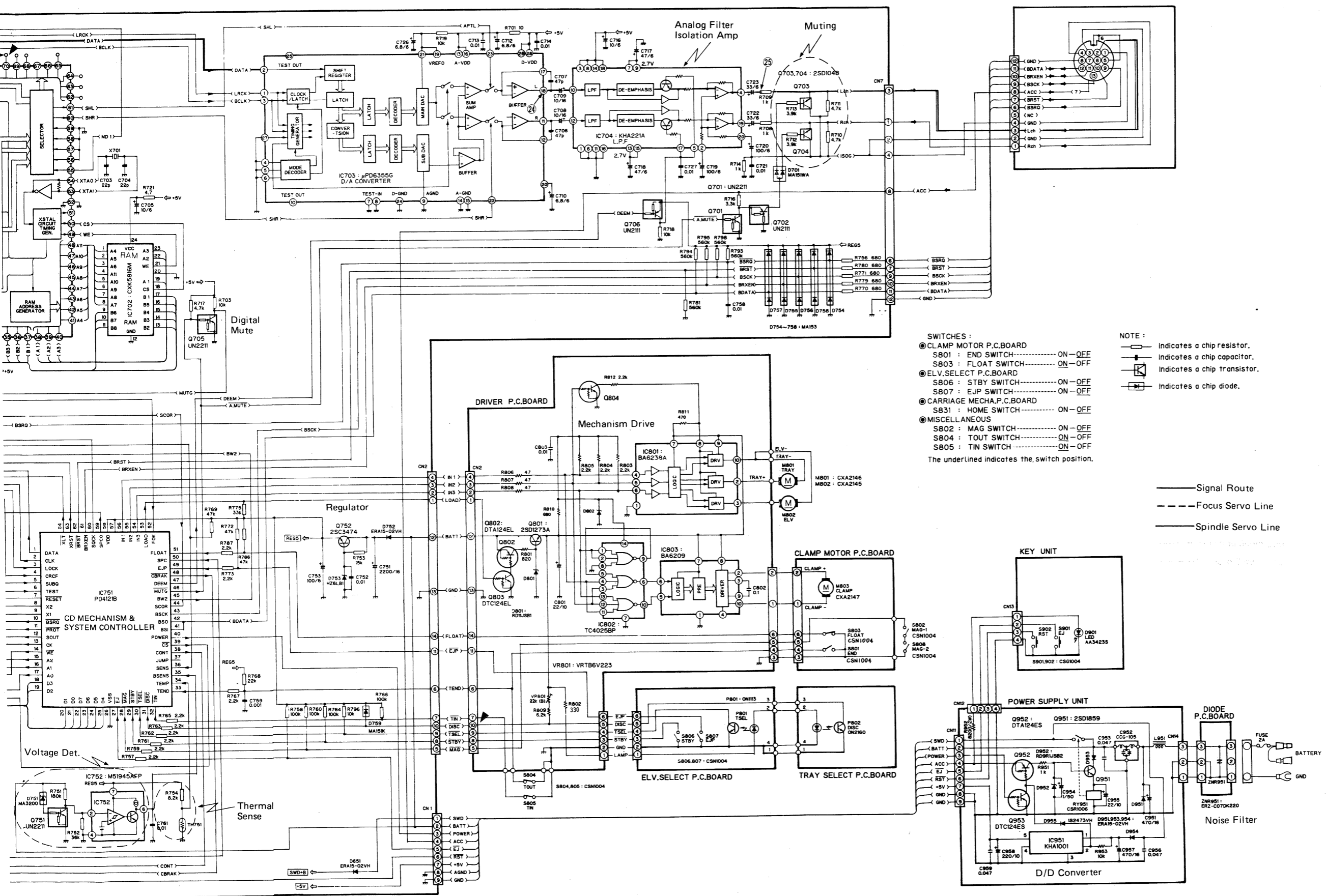

- SWITCHES :**
- CLAMP MOTOR P.C. BOARD
  - S801 : END SWITCH..... ON - OFF
  - S803 : FLOAT SWITCH..... ON - OFF
  - ELV.SELECT P.C. BOARD
  - S806 : STBY SWITCH..... ON - OFF
  - S807 : EJP SWITCH..... ON - OFF
  - CARRIAGE MECHA.P.C. BOARD
  - S831 : HOME SWITCH..... ON - OFF
  - MISCELLANEOUS
  - S802 : MAG SWITCH..... ON - OFF
  - S804 : TOUT SWITCH..... ON - OFF
  - S805 : TIN SWITCH..... ON - OFF
- The underlined indicates the switch position.

**NOTE :**

- Indicates a chip resistor.
- Indicates a chip capacitor.
- Indicates a chip transistor.
- Indicates a chip diode.

— Signal Route  
 - - - Focus Servo Line  
 ··· Spindle Servo Line

A

B

C

D

Fig. 78

MAIN UNIT

|       |       |       |       |      |       |       |       |       |
|-------|-------|-------|-------|------|-------|-------|-------|-------|
| IC703 | Q706  | IC704 | IC601 | Q601 | Q651  | IC658 | IC351 | Q704  |
| IC702 | IC701 | Q751  | Q601  | Q651 | IC653 | IC652 | Q701  | Q351  |
| IC754 | IC752 | IC751 | IC753 | Q705 | Q653  | IC654 | Q702  | Q351  |
| IC755 |       |       |       | Q652 |       |       | IC651 | Q703  |
| ADJ   |       |       | VR604 |      | VR601 |       | VR651 | VR351 |

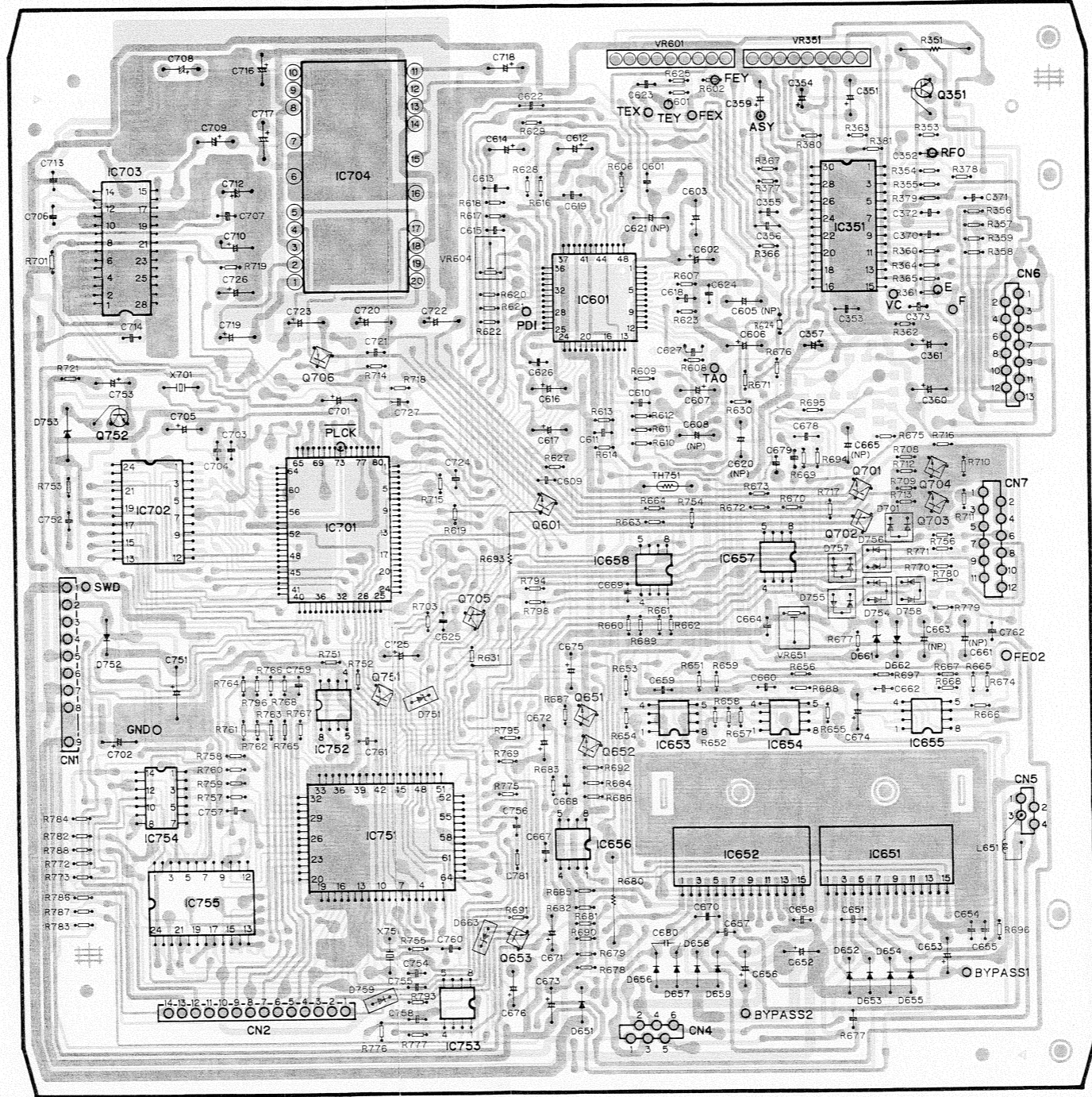

CDX-M100/UC  
Serial NO.  
00582 ~

CDX-M100/EW  
Serial NO.  
00001 ~

A

B

C

D

A

B

C

D

# 7. CONNECTION DIAGRAM

## MAIN UNIT

|      |                |               |                |       |               |               |       |              |               |                |       |                |               |               |                       |
|------|----------------|---------------|----------------|-------|---------------|---------------|-------|--------------|---------------|----------------|-------|----------------|---------------|---------------|-----------------------|
| IC,Q | IC703<br>IC702 | Q706<br>IC701 | IC754<br>IC751 | IC755 | Q706<br>IC752 | IC704<br>Q751 | IC753 | Q705<br>Q653 | IC651<br>Q651 | IC658<br>IC653 | IC652 | IC657<br>IC654 | IC351<br>Q701 | Q351<br>IC651 | Q704<br>Q703<br>IC655 |
| ADJ  |                |               |                |       |               |               | VR604 |              |               | VR601          |       | VR651          | VR351         |               |                       |

CDX-M100/UC  
Serial NO.  
~ 000581

## POWER SUPPLY UNIT

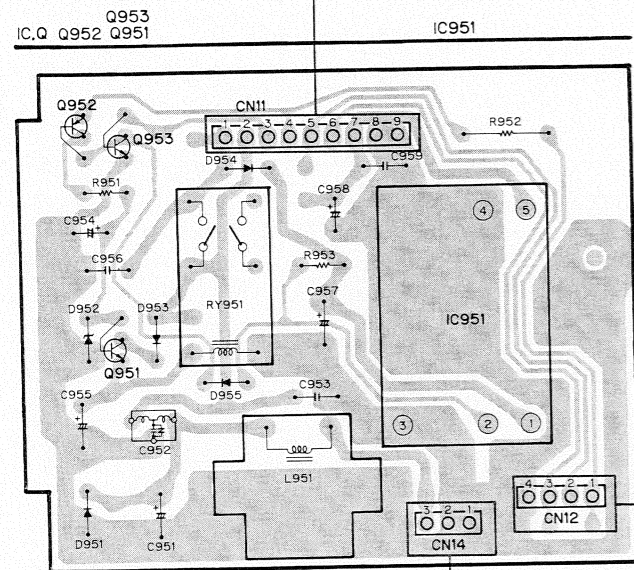

## KEY UNIT

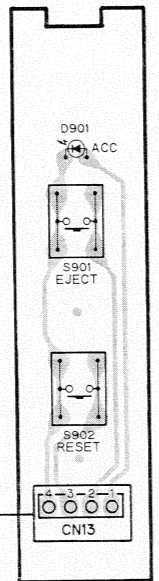

## DIODE P.C. BOARD

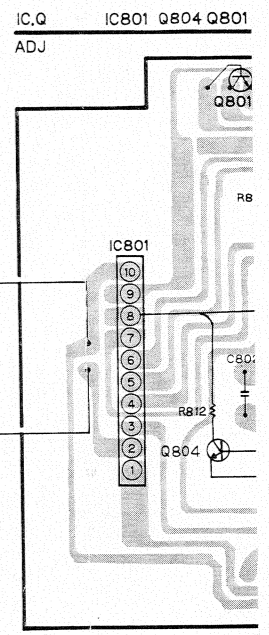
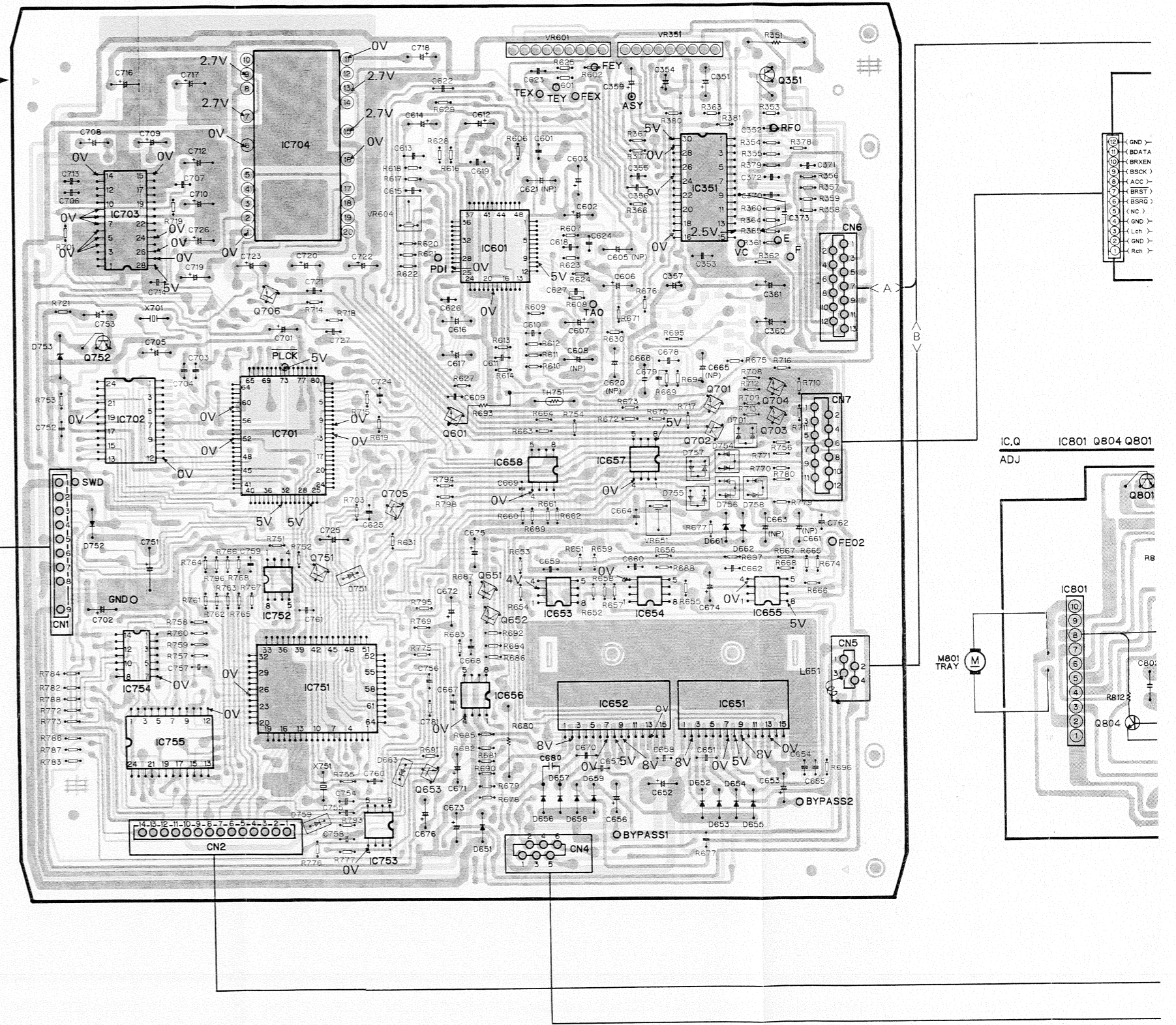
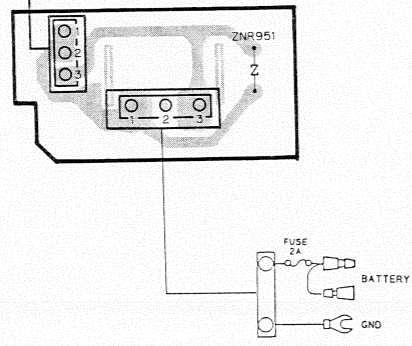

7

8

9

10

11

12

PICKUP UNIT (CGY1006)

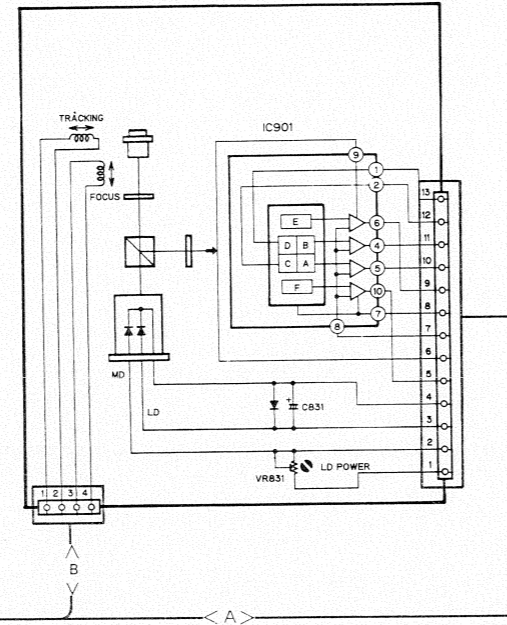

CARRIAGE MECHA P.C.BOARD

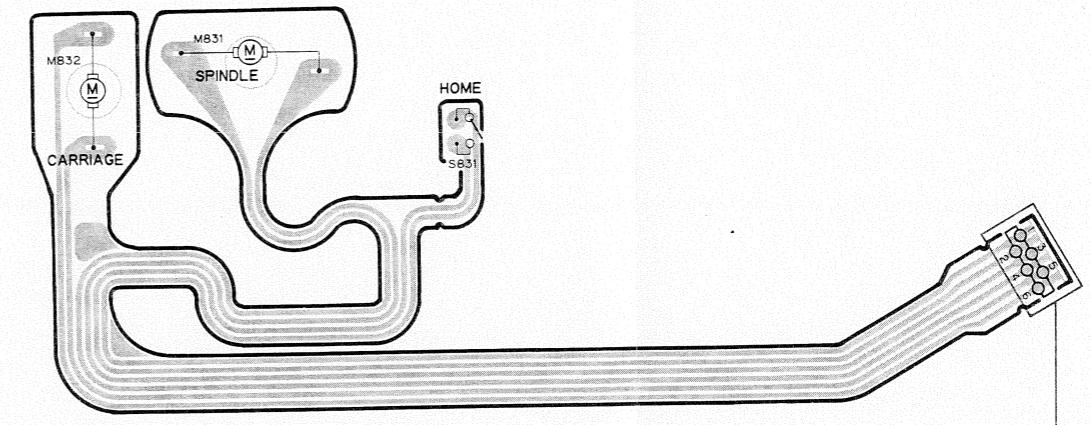

DRIVER P.C.BOARD

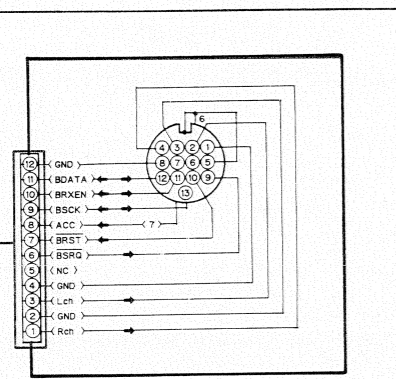

IC,Q IC801 Q804 Q801 IC803 IC802 Q802 Q803 ADJ

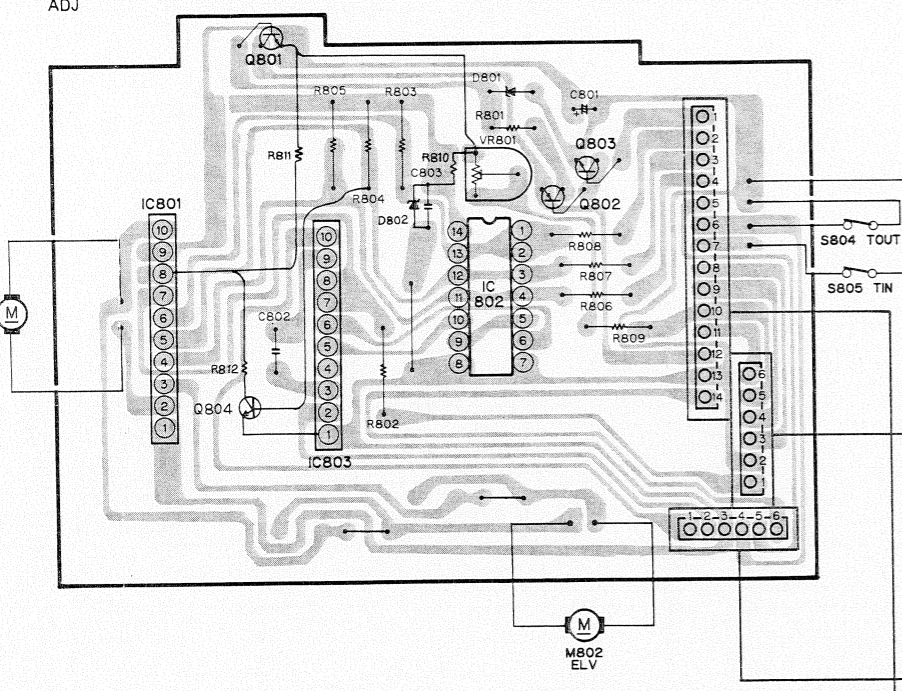

ELV.SELECT P.C.BOARD

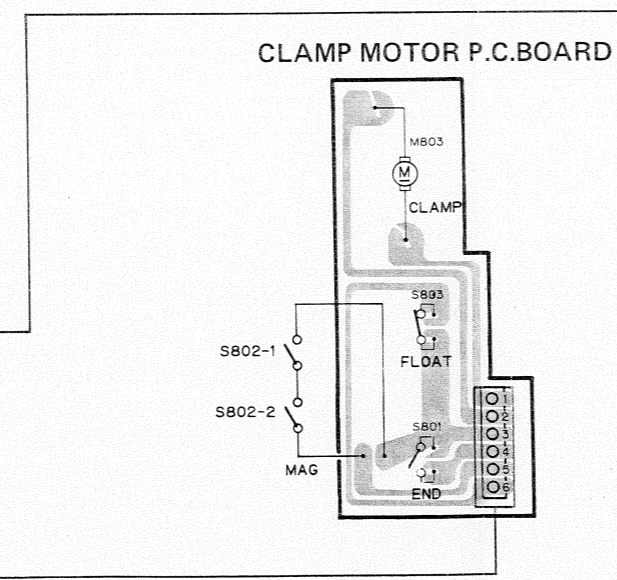

TRAY SELECT P.C.BOARD

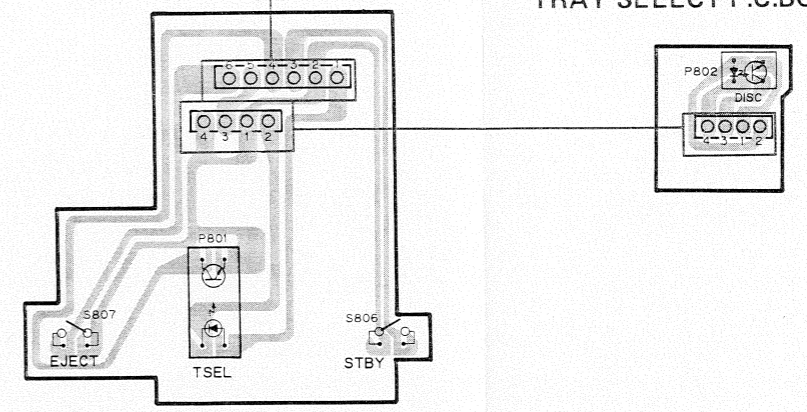

A

B

C

D

Fig. 79

7

8

9

10

11

12

Note: 1. The encircled numbers denote measuring points in the circuit diagram.  
 2. Reference voltage  
 G: GND VC: Pin 9 of CXA1081M (2.5V)

● Wave Forms

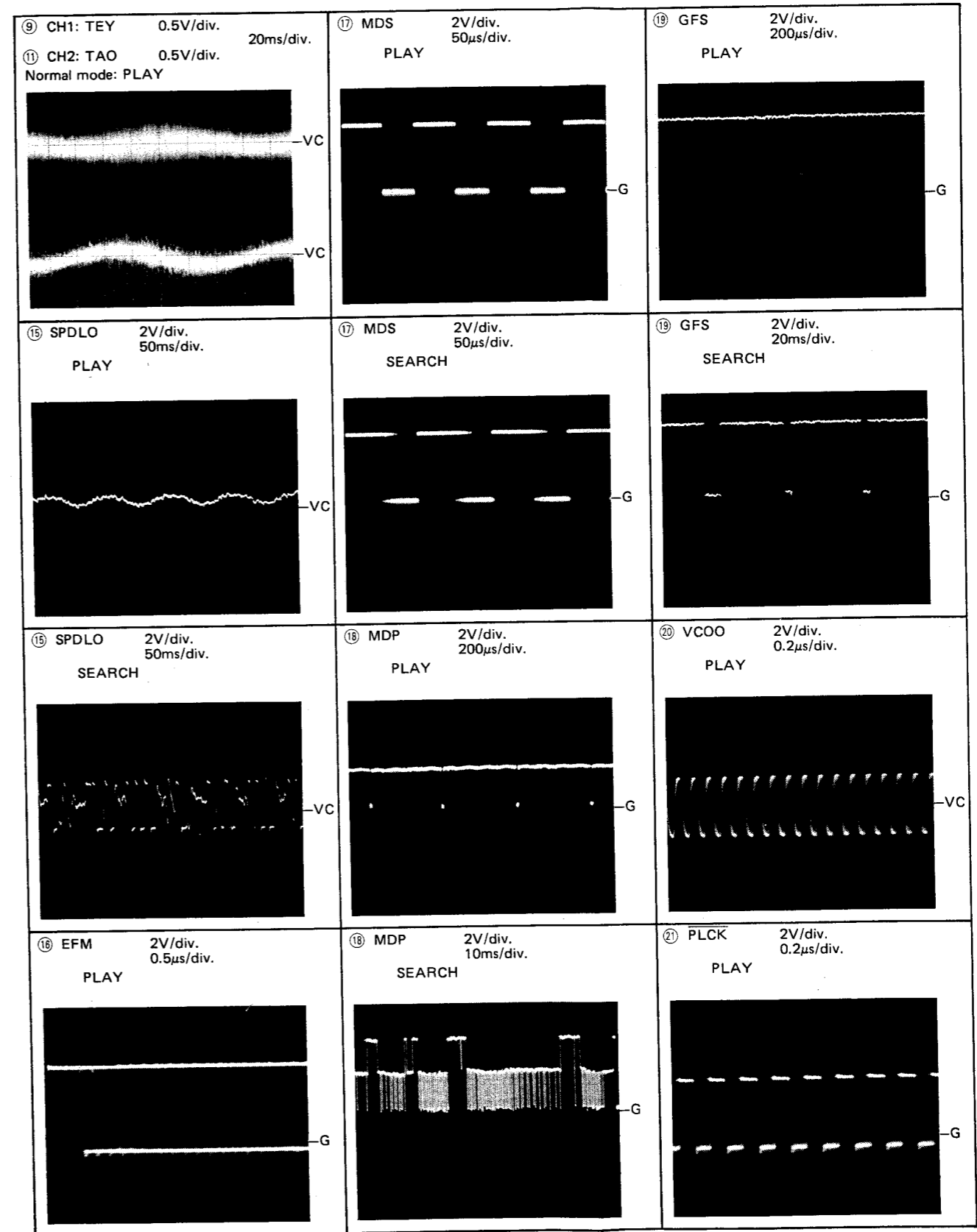
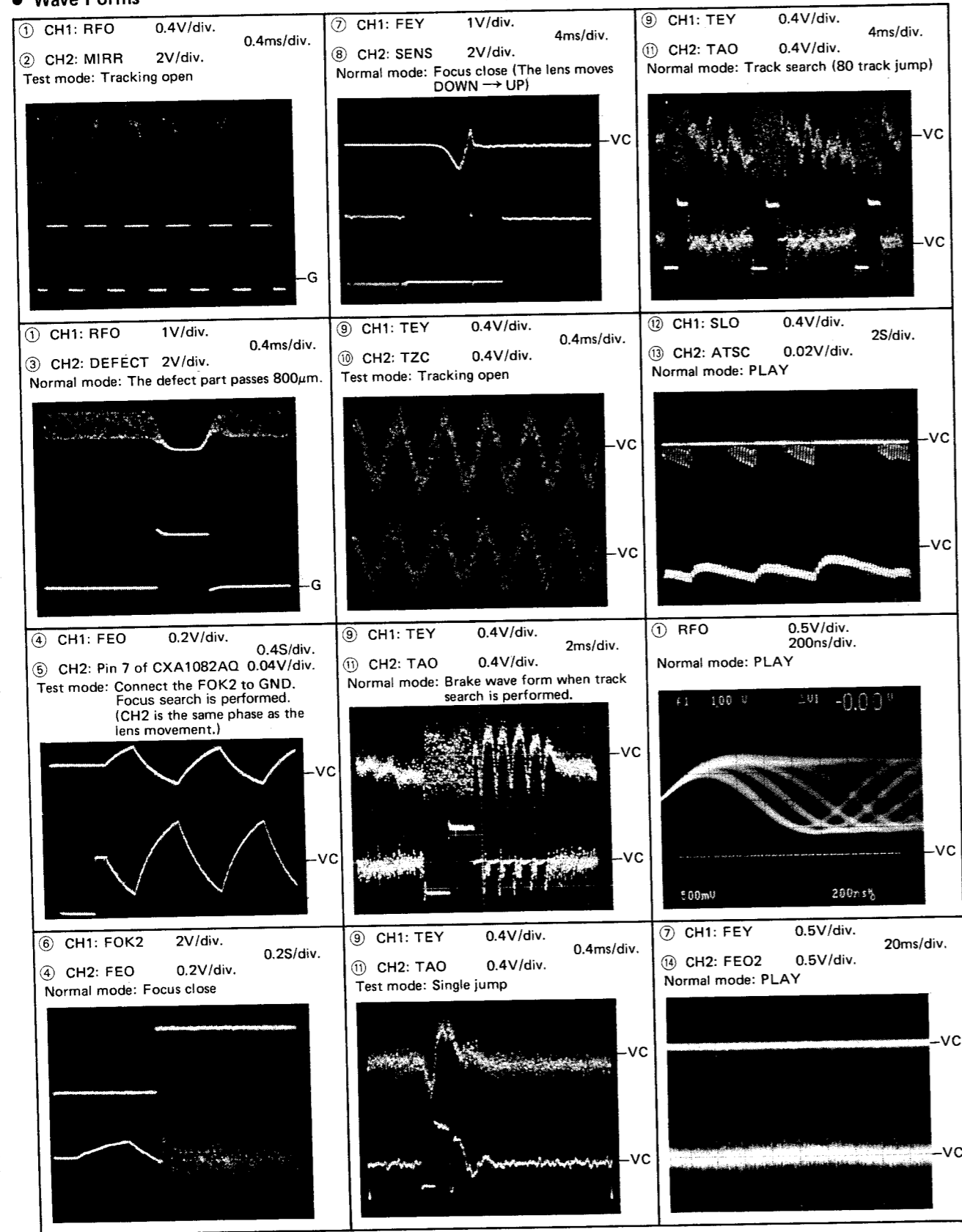

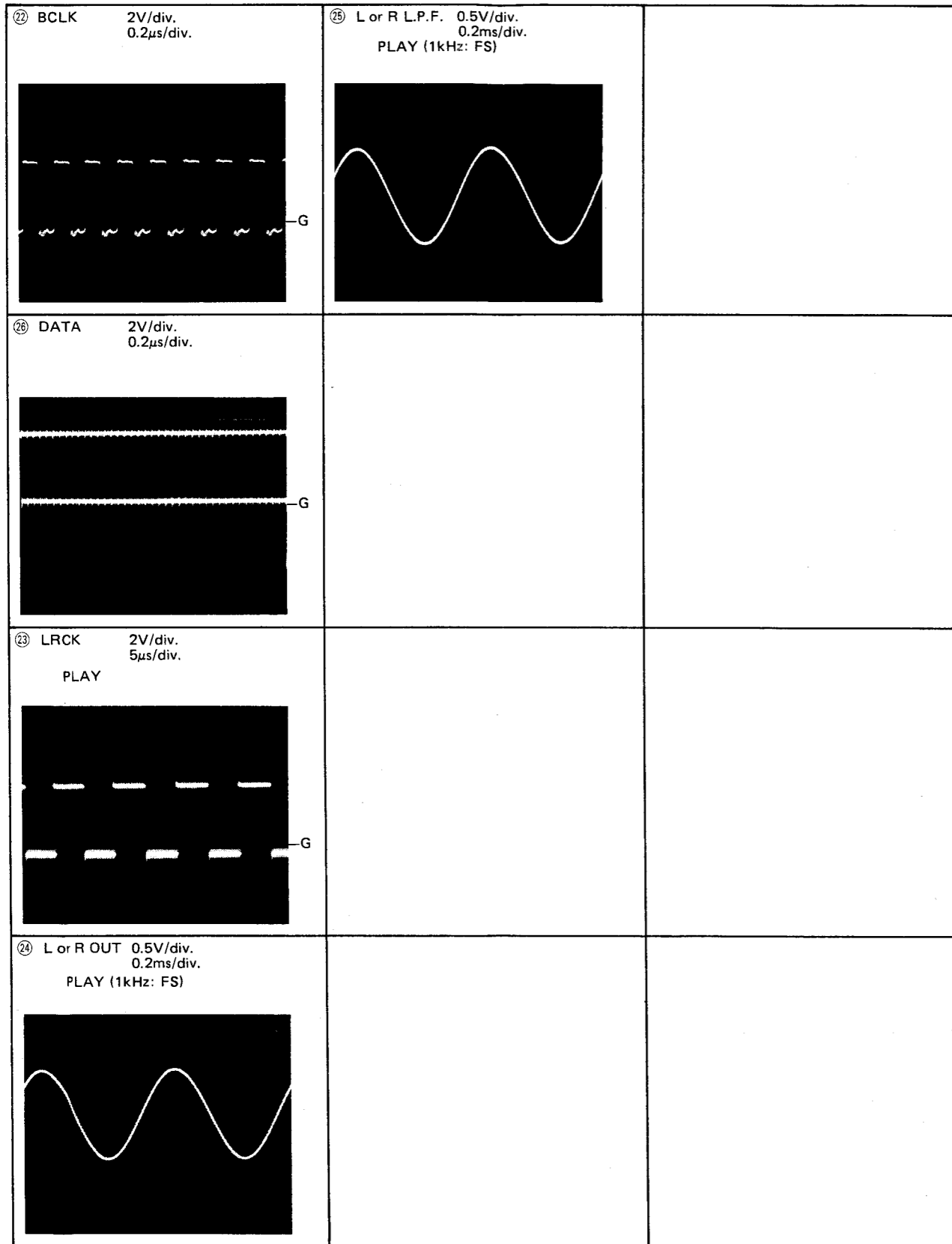

## 8. CHASSIS EXPLODED VIEW

### NOTE:

- For your parts Stock Control, the fast moving items are indicated with the marks ★★ and ★.
- ★★: GENERALLY MOVES FASTER THAN ★.
- This classification shall be adjusted by each distributor because it depends on model number, temperature, humidity, etc.
- Parts whose parts numbers are omitted are subject to being not supplied.
- Parts marked by "●" are not always kept in stock. Their delivery time may be longer than usual or they may be unavailable.

### • Parts List

| Mark | No. | Part No.     | Description | Mark | No. | Part No.     | Description       |
|------|-----|--------------|-------------|------|-----|--------------|-------------------|
|      | 1   |              | Sheet       |      | 31  | BPZ20P050FMC | Screw             |
|      | 2   | CBH1096      | Spring      |      | 32  |              | Connector         |
|      | 3   | CXA2104      | Grille Unit |      | 33  |              | Holder            |
|      | 4   | SMZ40H160FZK | Screw       |      | 34  | CNS1338      | Grille            |
|      | 5   |              | Cushion     |      | 35  |              | Insulator         |
|      | 6   |              | Spacer      |      | 36  | CNV1567      | Collar            |
|      | 7   |              | Arm         |      | 37  | CBA1065      | Screw             |
|      | 8   | CBH1097      | Spring      |      | 38  | CNV1565      | Damper            |
| ★    | 9   | CAC1433      | Button      |      | 39  | CBH1099      | Spring            |
|      | 10  | CNS1491      | Grille      |      |     |              |                   |
|      | 11  |              | Lever       |      | 40  |              | Bracket           |
|      | 12  |              | Holder      |      | 41  | HEF-102      | Clamper           |
|      | 13  | BPZ26P080FMC | Screw       |      | 42  | BMZ26P040FMC | Screw             |
|      | 14  |              | Packing     |      | 43  | BMZ40P200FRD | Screw             |
|      | 15  | BMZ30P040FZK | Screw       |      | 44  |              | Spacer            |
|      | 16  | CNM1658      | Packing     |      | 45  |              | Chassis           |
|      | 17  | CNV1617      | Cover       |      | 46  |              | Plug              |
|      | 18  | PMS30P060FZK | Screw       |      | 47  |              | Plug              |
|      | 19  |              | Case        |      | 48  |              | Plug              |
|      | 20  |              | Insulator   |      | 49  |              | Bracket           |
|      | 21  | PMS26P040FMC | Screw       |      | 50  |              | Connector         |
|      | 22  | BMZ26P060FMC | Screw       | ●    | 51  |              | Connector         |
|      | 23  |              | Holder      |      | 52  | CWR1007      | Power Supply Unit |
|      | 24  | CKS1328      | Connector   |      | 53  | CNP1435      | P.C. Board        |
|      | 25  | CKS1122      | Connector   |      | 54  | CKP1003      | Socket            |
|      | 26  | CKS-719      | Connector   |      | 55  | CNT1018      | Spacer            |
|      | 27  | CKS-721      | Connector   |      | 56  | CNT1019      | Spacer            |
|      | 28  |              | Plug        |      | 57  | BMZ20P040FMC | Screw             |
|      | 29  |              | Connector   |      | 58  | CLA1321      | Collar            |
| ●    | 30  | CWX1057      | Main Unit   |      | 59  | CBA1078      | Screw             |
|      |     |              |             |      | 60  | BMZ50P300FRD | Screw             |
|      |     |              |             |      | 61  |              | Cover             |
|      |     |              |             |      | 62  | PMS20P025FMC | Screw             |
|      |     |              |             |      | 63  | CBA1081      | Screw             |
|      |     |              |             |      | 64  | CNV1203      | Clamper           |

• Chassis

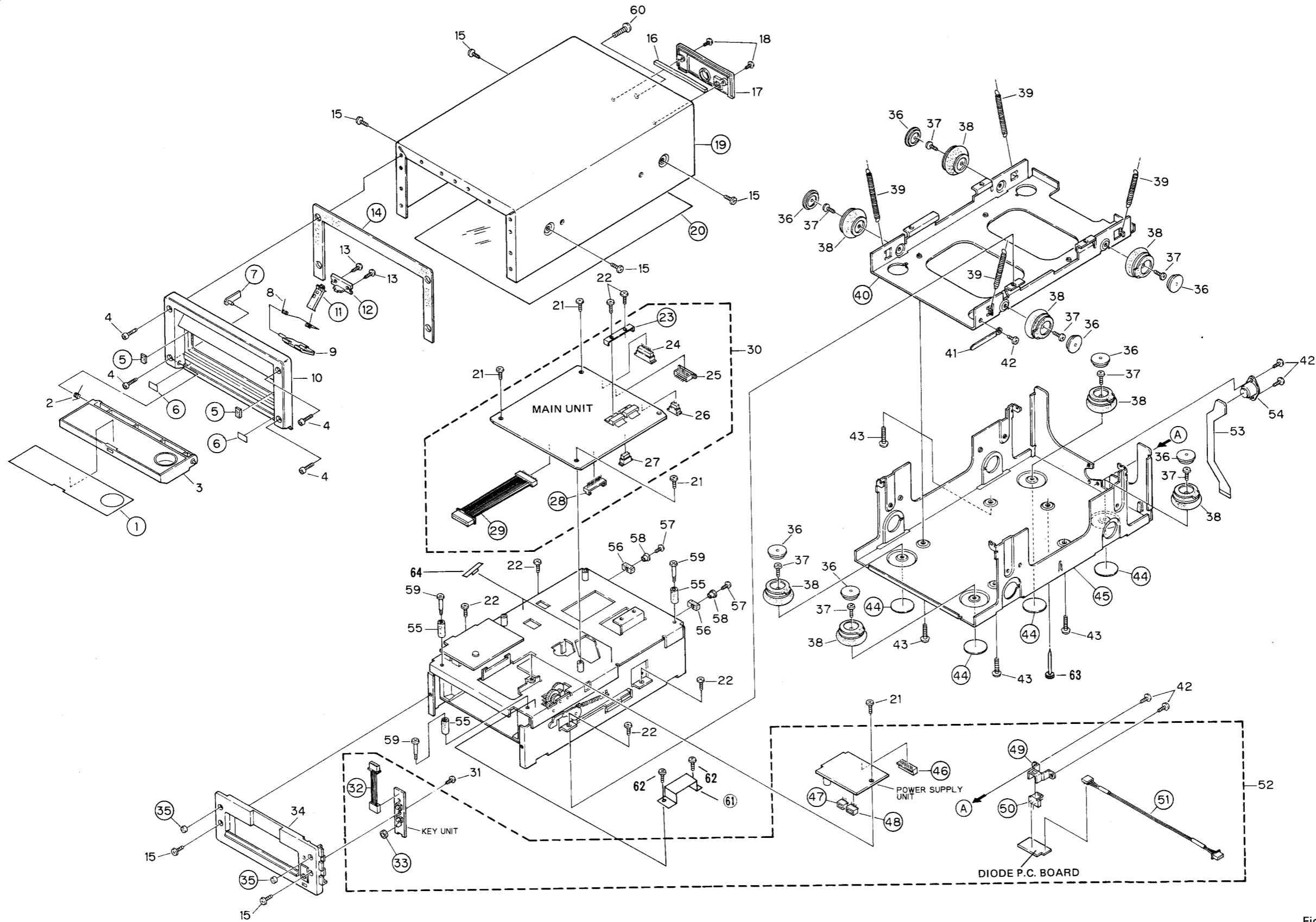

Fig. 80



### 9. CD MECHANISM UNIT (1) EXPLODED VIEW

A

B

C

D

A

B

C

D

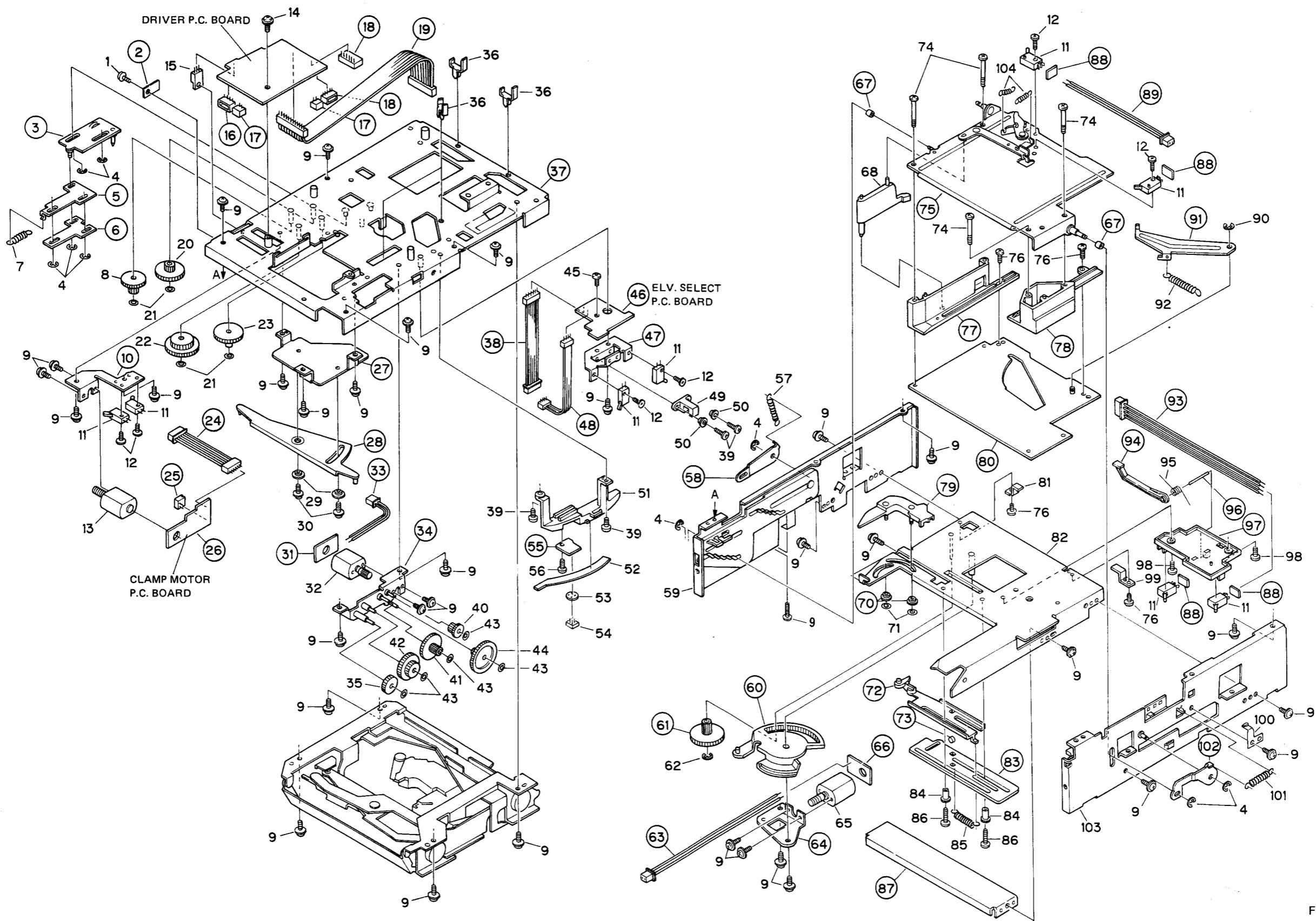

Fig. 81

• Parts List

| Mark | No. | Part No.     | Description        | Mark | No. | Part No.     | Description       | Mark | No. | Part No. | Description     |
|------|-----|--------------|--------------------|------|-----|--------------|-------------------|------|-----|----------|-----------------|
|      | 1   | BMZ20P030FMC | Screw              |      | 46  |              | P.C.Board         |      | 91  |          | Arm             |
|      | 2   |              | Holder             |      | 47  |              | Bracket           |      | 92  | CBH1115  | Spring          |
|      | 3   |              | Buffer Unit        |      | 48  |              | Connector         |      | 93  |          | Connector       |
|      | 4   | YE15FUC      | Washer             |      | 49  | ON1113       | Photo-Interrupter |      | 94  |          | Arm             |
|      | 5   |              | Lever              |      | 50  | CNV1562      | Bush              |      | 95  | CBH1127  | Spring          |
|      | 6   |              | Lever              |      | 51  | CNV1543      | Guide             |      | 96  |          | Shaft           |
|      | 7   | CBH1124      | Spring             |      | 52  | CNM1675      | Sheet             |      | 97  |          | Bracket         |
|      | 8   | CNV1533      | Gear               |      | 53  | CNY-199      | Spacer            |      | 98  | CBA1080  | Screw           |
|      | 9   | PMS20P025FMC | Screw              |      | 54  | ON2160       | Photo-Interrupter |      | 99  | CNV1555  | Guide           |
|      | 10  |              | Bracket            |      | 55  |              | P.C.Board         |      | 100 | CBL1044  | Spring          |
| ★★   | 11  | CSN-094      | Switch             |      | 56  | PBZ20P060FMC | Screw             |      | 101 | CBH1126  | Spring          |
|      | 12  | CBA1025      | Screw              |      | 57  | CBH1126      | Spring            |      | 102 |          | Arm             |
| ★★   | 13  | CXA2147      | Motor Unit (CLAMP) |      | 58  |              | Arm               |      | 103 | CXA1876  | Side Frame Unit |
|      | 14  | PMS26P040FMC | Screw              |      | 59  | CXA1875      | Side Frame Unit   |      | 104 | CBH1114  | Spring          |
| ★★   | 15  | 2SD1273A     | Transistor         |      | 60  |              | Arm Gear          |      |     |          |                 |
|      | 16  |              | Plug               |      | 61  |              | Gear              |      |     |          |                 |
|      | 17  |              | Plug               |      | 62  | YE20FUC      | Washer            |      |     |          |                 |
|      | 18  |              | Plug               |      | 63  |              | Connector         |      |     |          |                 |
|      | 19  |              | Connector          |      | 64  |              | Bracket           |      |     |          |                 |
|      | 20  | CNV1528      | Gear               | ★★   | 65  | CXA2146      | Motor Unit (TRAY) |      |     |          |                 |
|      | 21  | CBF1024      | Washer             |      | 66  |              | Bracket           |      |     |          |                 |
|      | 22  | CNV1526      | Gear               |      | 67  |              | Roller            |      |     |          |                 |
|      | 23  | CNV1527      | Gear               |      | 68  | CNV1549      | Arm               |      |     |          |                 |
|      | 24  |              | Connector          |      | 69  | .....        |                   |      |     |          |                 |
|      | 25  |              | Connector          |      | 70  |              | Roller            |      |     |          |                 |
|      | 26  |              | P.C.Board          |      | 71  | YE12FUC      | Washer            |      |     |          |                 |
|      | 27  |              | Bracket            |      | 72  |              | Slide Plate       |      |     |          |                 |
|      | 28  |              | Arm Unit           |      | 73  |              | Roller            |      |     |          |                 |
|      | 29  | CLA1037      | Collar             |      | 74  | CBA1063      | Screw             |      |     |          |                 |
|      | 30  | CBA1026      | Screw              |      | 75  |              | Holder Unit       |      |     |          |                 |
|      | 31  |              | P.C.Board          |      | 76  | CBA1037      | Screw             |      |     |          |                 |
| ★★   | 32  | CXA2145      | Motor Unit (ELV)   |      | 77  |              | Guide             |      |     |          |                 |
|      | 33  |              | Connector          |      | 78  |              | Guide             |      |     |          |                 |
|      | 34  |              | Bracket Unit       |      | 79  |              | Arm               |      |     |          |                 |
|      | 35  | CNV1540      | Gear               |      | 80  |              | Holder Unit       |      |     |          |                 |
|      | 36  | CNV1558      | Holder             |      | 81  | CNV1554      | Guide             |      |     |          |                 |
|      | 37  |              | Chassis Unit       |      | 82  | CXA1877      | Sub Chassis Unit  |      |     |          |                 |
|      | 38  |              | Connector          |      | 83  |              | Slide Plate       |      |     |          |                 |
|      | 39  | CBA1080      | Screw              |      | 84  | CLA1263      | Collar            |      |     |          |                 |
|      | 40  | CNV1539      | Gear               |      | 85  | CBH1128      | Spring            |      |     |          |                 |
|      | 41  | CNV1537      | Gear               |      | 86  | BMZ20P080FMC | Screw             |      |     |          |                 |
|      | 42  | CNV1536      | Gear               |      | 87  |              | Bracket           |      |     |          |                 |
|      | 43  | CBF-046      | Washer             |      | 88  |              | P.C.Board         |      |     |          |                 |
|      | 44  | CNV1538      | Gear               |      | 89  |              | Connector         |      |     |          |                 |
|      | 45  | CBA1037      | Screw              |      | 90  | YE20FUC      | Washer            |      |     |          |                 |

10. CD MECHANISM UNIT (2) EXPLODED VIEW

A

B

C

D

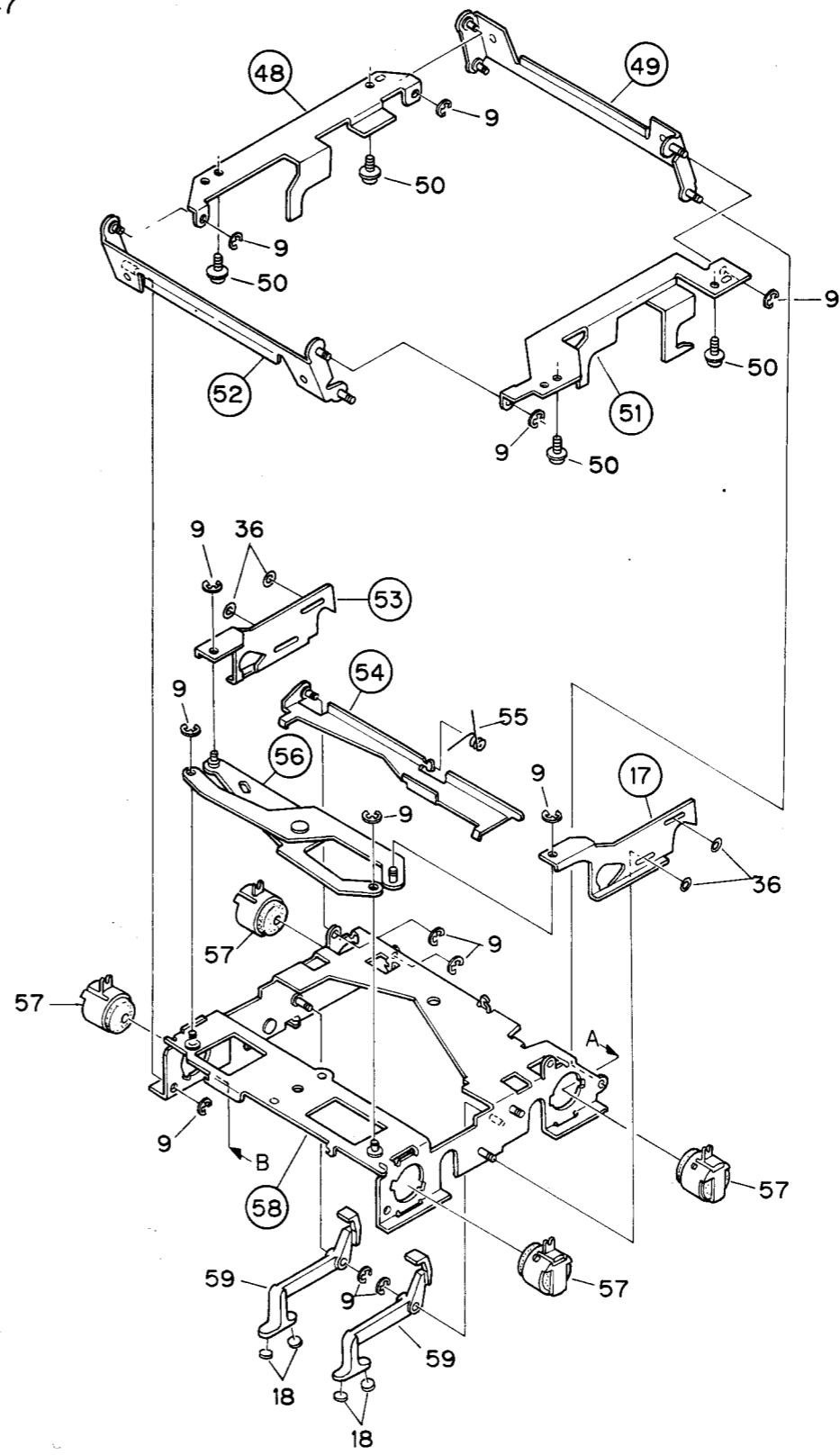
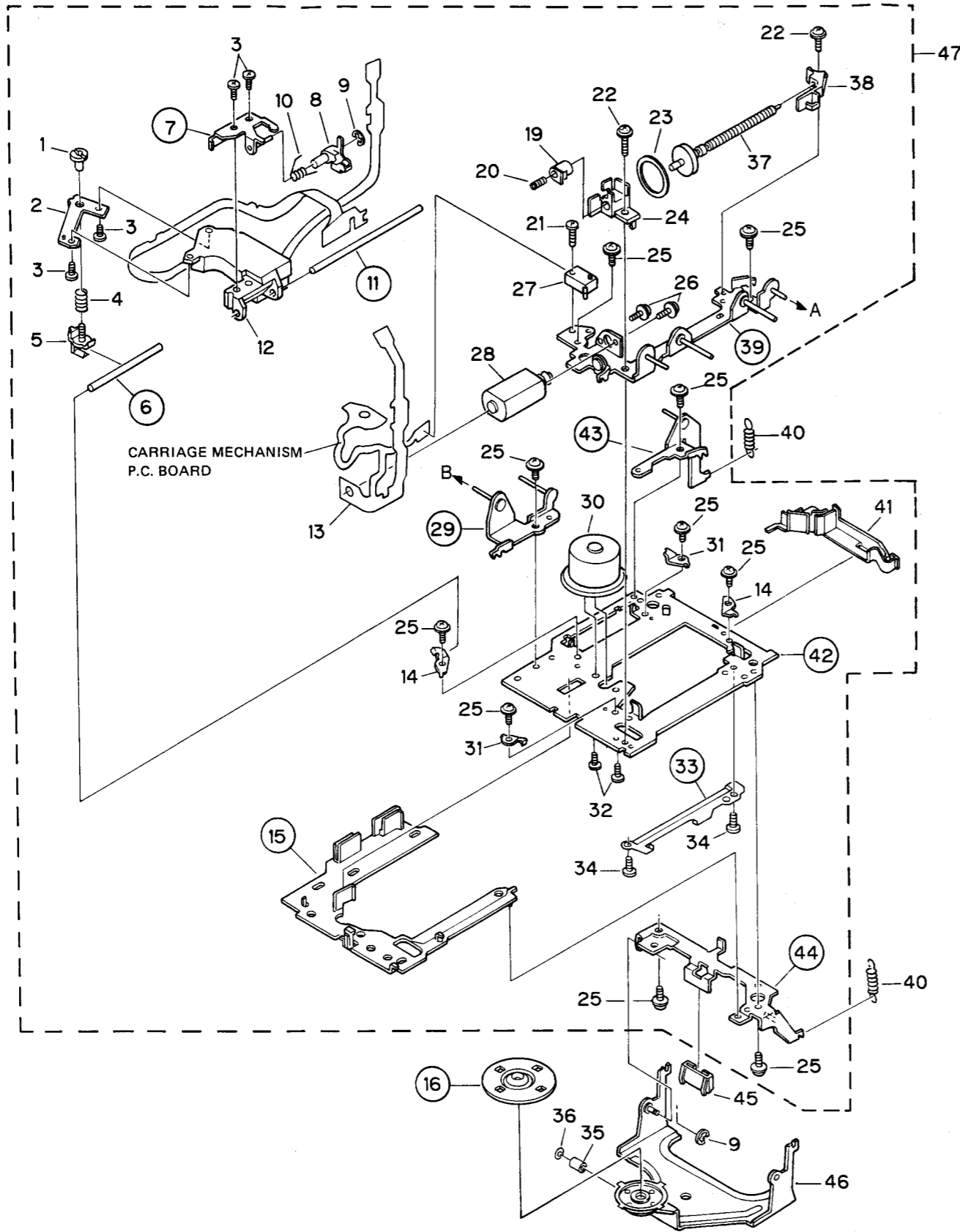

A

B

C

D

Fig. 82

• Parts List

| Mark | No. | Part No.     | Description          | Mark | No. | Part No.     | Description             |
|------|-----|--------------|----------------------|------|-----|--------------|-------------------------|
|      | 1   | CLA1319      | Screw                |      | 31  | CNC1738      | Holder                  |
|      | 2   | CNC1736      | Holder               |      | 32  | HBA-163      | Screw                   |
|      | 3   | CBA1062      | Screw                |      | 33  |              | Cover                   |
|      | 4   | CBH1105      | Spring               |      | 34  | CBA1061      | Screw                   |
|      | 5   | CNV1512      | Holder               |      | 35  | CNV1559      | Roller                  |
|      | 6   |              | Shaft                |      | 36  | CBF-046      | Washer                  |
|      | 7   |              | Holder Unit          |      | 37  | CXA1861      | Screw Unit              |
|      | 8   | CNV1513      | Luck                 |      | 38  | CNV1511      | Holder                  |
|      | 9   | YE15FUC      | Washer               |      | 39  |              | Bracket Unit            |
|      | 10  | CBH1106      | Spring               |      | 40  | CBH1117      | Spring                  |
|      | 11  |              | Shaft                |      | 41  | CNV1515      | Holder                  |
|      | 12  | CGY1006      | Pickup Unit          |      | 42  |              | Chassis                 |
|      | 13  | CNP1612      | P.C.Board            |      | 43  |              | Bracket Unit            |
|      | 14  | CNC1739      | Holder               |      | 44  |              | Bracket Unit            |
|      | 15  |              | Cover                |      | 45  | CNV1516      | Guide                   |
|      | 16  |              | Guide                |      | 46  | CXA2149      | Arm Unit                |
|      | 17  |              | Slide Plate          | ●    | 47  | CXA1855      | Carriage Mechanism Unit |
|      | 18  | CNM1676      | Sheat                |      | 48  |              | Bracket                 |
|      | 19  | CNV1509      | Spacer               |      | 49  |              | Arm Unit                |
|      | 20  | CBH1104      | Spring               |      | 50  | PMS20P025FMC | Screw                   |
|      | 21  | CBA1070      | Screw                |      | 51  |              | Bracket                 |
|      | 22  | PMS20P050FMC | Screw                |      | 52  |              | Arm Unit                |
| ★    | 23  | CNT1020      | Belt                 |      | 53  |              | Slide Plate             |
|      | 24  | CNV1510      | Holder               |      | 54  |              | Arm Unit                |
|      | 25  | PMS20P030FMC | Screw                |      | 55  | CBH1125      | Spring                  |
|      | 26  | CBA-098      | Screw                |      | 56  |              | Arm Unit                |
| ★★   | 27  | CSN-094      | Switch               |      | 57  | CXA2139      | Damper Unit             |
| ★★   | 28  | CXA2133      | Motor Unit(Carriage) |      | 58  |              | Holder Unit             |
|      | 29  |              | Bracket Unit         |      | 59  | CNV1544      | Guide                   |
| ★★   | 30  | CXM1018      | Motor Unit(Spindle)  |      |     |              |                         |

# 11. ELECTRICAL PARTS LIST

**NOTE:**

- For your parts Stock Control, the fast moving items are indicated with the marks \*\* and \*.  
 \*\* : **GENERALLY MOVES FASTER THAN \***.  
 This classification shall be adjusted by each distributor because it depends on model number, temperature, humidity, etc.
- Parts whose parts numbers are omitted are subject to being not supplied.
- The part numbers shown below indicate chip components.

**Chip Resistor**

RS1/8S□□□J, RS1/10S□□□J

**Chip Capacitor (except for CQS.....)**

CKS....., CCS....., CSZS.....

Unit Number :  
 Unit Name : Power Supply Unit

Unit Number :  
 Unit Name : Main Unit

**MISCELLANEOUS**

| Mark | Circuit Symbol & No. | Part Name  | Part No.   |
|------|----------------------|------------|------------|
| **   | IC 951               |            | KHA1001    |
| **   | Q 951                |            | 2SD1859    |
| **   | Q 952                |            | DTA124ES   |
| **   | Q 953                |            | DTC124ES   |
| *    | D 951 953 954        |            | ERA15-02VH |
| *    | D 952                |            | RD9R1JSB2  |
| *    | D 955                |            | 1S2473VH   |
|      | L 951                | Choke Coil | CTF-002    |
|      | RY 951               | Relay      | CSR1006    |

**RESISTORS**

| Mark | Circuit Symbol & No. | Part Name | Part No.     |
|------|----------------------|-----------|--------------|
|      | R 951                |           | RD1/4VM102J  |
|      | R 952                |           | RD1/2PS821JL |
|      | R 953                |           | RD1/4VM103J  |

**CAPACITORS**

| Mark | Circuit Symbol & No. | Part Name | Part No.    |
|------|----------------------|-----------|-------------|
|      | C 951 957            |           | CEA471M16L2 |
|      | C 952                |           | CCG-105     |
|      | C 953 956 959        |           | CKCYF473Z50 |
|      | C 954                |           | CEA010M50LL |
|      | C 955                |           | CEA220M10L2 |
|      | C 958                |           | CEAUH221M10 |

Unit Number :  
 Unit Name : Diode P.C.Board

| Mark | Circuit Symbol & No. | Part Name      | Part No.     |
|------|----------------------|----------------|--------------|
|      | ZNR951               | Surge Absorber | ERZ-C070K220 |

Unit Number :  
 Unit Name : Key Unit

| Mark | Circuit Symbol & No. | Part Name | Part No. |
|------|----------------------|-----------|----------|
| *    | D 901                | LED       | AA3423S  |
| **   | S 901 902            | Switch    | CSG1004  |

**MISCELLANEOUS**

| Mark | Circuit Symbol & No.              | Part Name                     | Part No.     |
|------|-----------------------------------|-------------------------------|--------------|
| **   | IC 351                            |                               | CXA1081M     |
| **   | IC 601                            |                               | CXA1082AQ    |
| **   | IC 651 652                        |                               | PA3021B      |
| **   | IC 653                            |                               | μ PC358G     |
| **   | IC 654 655 657 658                |                               | M5218FP      |
| **   | IC 656                            |                               | M5233FP      |
| **   | IC 701                            |                               | CXD1135Q     |
| **   | IC 702 755                        |                               | CXK5816M-15L |
| **   | IC 703                            |                               | μ PD6355G    |
| **   | IC 704                            |                               | KHA221A      |
| **   | IC 751                            |                               | PD4121B      |
| **   | IC 752                            |                               | M51945AFP    |
| **   | IC 753                            |                               | M51955AFP    |
| **   | IC 754                            |                               | TC40H164F    |
| **   | Q 351                             |                               | 2SB1243      |
| **   | Q 601 703 704                     | Chip Transistor               | 2SD1048      |
| **   | Q 651 652 653 701 705 751         | Chip Transistor               | UN2211       |
| **   | Q 702 706                         | Chip Transistor               | UN2111       |
| **   | Q 752                             |                               | 2SC3474      |
| *    | D 651 752                         |                               | ERA15-02VH   |
| *    | D 652 653 654 655 656 657 658 659 |                               | ERA82-004VH  |
| *    | D 661 662                         |                               | HZS2ALL      |
| *    | D 663 751                         | Chip Diode                    | MA3200       |
| *    | D 701                             | Chip Diode                    | MA151WA      |
| *    | D 753                             |                               | HZ6LB1       |
| *    | D 754 755 756 757 758             | Chip Diode                    | MA153        |
| *    | D 759                             | Chip Diode                    | MA151K       |
|      | TH 751                            | Thermister                    | CCX-021      |
| X    | 701                               | Xtal Resonator                | CSS1009      |
| X    | 751                               | Ceramic Resonator             | CSS-042      |
| **   | VR 351                            | Semi-fixed 47kΩ(B)×4          | CCP1006      |
| **   | VR 601                            | Semi-fixed 47kΩ(B), 10kΩ(B)×2 | CCP1005      |
| **   | VR 604                            | Semi-fixed 2.2kΩ(B)           | HCP-267      |
| **   | VR 651                            | Semi-fixed 47kΩ(B)            | HCP-275      |
| L    | 651                               | Coil                          | CTH1035      |

RESISTORS

| Mark | Circuit Symbol & No.                    | Part Name | Part No.     |
|------|---|-----------|--------------|
| R    | 351                                     |           | RS1/2P220JL  |
| R    | 353 831                                 |           | RS1/10S272J  |
| R    | 354 363 378 616 628 768                 |           | RS1/10S223J  |
| R    | 355 610 625                             |           | RS1/10S113J  |
| R    | 358 357 358 359 669 694                 |           | RS1/10S563J  |
| R    | 360 361                                 |           | RS1/10S124J  |
| R    | 362 781 793 794 795 798                 |           | RS1/10S564J  |
| R    | 364 365 618 671 685 695                 |           | RS1/10S105J  |
| R    | 366 377 666                             |           | RS1/10S562J  |
| R    | 367 609 614 619 627 758                 |           | RS1/10S104J  |
| R    | 379 687 688 710 711 717                 |           | RS1/10S472J  |
| R    | 380 617 681 682                         |           | RS1/10S203J  |
| R    | 381 708 709 714 783                     |           | RS1/10S102J  |
| R    | 601 602 676 677 683 690                 |           | RS1/10S101J  |
| R    | 606                                     |           | RS1/10S224J  |
| R    | 607                                     |           | RS1/10S683J  |
| R    | 608                                     |           | RS1/10S823J  |
| R    | 611                                     |           | RS1/10S432J  |
| R    | 612                                     |           | RS1/10S623J  |
| R    | 613                                     |           | RS1/10S754J  |
| R    | 620 674 716                             |           | RS1/10S332J  |
| R    | 621 751                                 |           | RS1/10S184J  |
| R    | 622 651 652 653 654 655 656 657 658 659 |           | RS1/10S103J  |
| R    | 623 624                                 |           | RS1/10S393J  |
| R    | 629 630                                 |           | RS1/10S273J  |
| R    | 660 661 662 663 664 670 687 688         |           | RS1/10S103J  |
| R    | 665                                     |           | RS1/10S821J  |
| R    | 668 712 713                             |           | RS1/10S392J  |
| R    | 672                                     |           | RS1/10S364J  |
| R    | 673 760 764 766 769 772 777 786         |           | RS1/10S473J  |
| R    | 675                                     |           | RS1/10S682J  |
| R    | 678                                     |           | RS1/10S223J  |
| R    | 679                                     |           | RS1/10S392J  |
| R    | 680                                     |           | RS1P1R5JL    |
| R    | 684                                     |           | RS1/10S472J  |
| R    | 689 691 696 697 703 715 718 719 755     |           | RS1/10S103J  |
| R    | 692                                     |           | RS1/10S105J  |
| R    | 693                                     |           | RD1/4PS222JL |
| R    | 701                                     |           | RS1/10S100J  |
| R    | 721                                     |           | RS1/10S4R7J  |
| R    | 752                                     |           | RS1/10S363J  |
| R    | 753                                     |           | RS1/10S153J  |
| R    | 754                                     |           | RS1/10S822J  |
| R    | 756 770 771 779 780                     |           | RS1/10S681J  |
| R    | 757 759 761 762 763 765 767 773 787     |           | RS1/10S222J  |
| R    | 775 796                                 |           | RS1/10S333J  |
| R    | 776                                     |           | RS1/10S683J  |
| R    | 782 784 788                             |           | RS1/10S104J  |

CAPACITORS

| Mark | Circuit Symbol & No.                    | Part Name | Part No.      |
|------|---|-----------|---------------|
| C    | 351 719 720 753                         |           | CEA101M6R3LL  |
| C    | 352 355 371 611 625 626 655 657 659 660 |           | CKSQYB103K50  |
| C    | 353 613 622 666                         |           | CKSYB333K25   |
| C    | 354 357                                 |           | CSYA330M6R30S |
| C    | 356                                     |           | CKSYB332K50   |

| Mark | Circuit Symbol & No.                    | Part Name   | Part No.      |
|------|---|-------------|---------------|
| C    | 359 614                                 |             | CEAR47M50LL   |
| C    | 360 361 674 705 716                     |             | CSYA100M6R30S |
| C    | 370 703 704                             |             | CCSQCH220J50  |
| C    | 372                                     |             | CCSQCH100D50  |
| C    | 373                                     |             | CCSQCH220J50  |
| C    | 601 654 658                             |             | CKSQYB222K50  |
| C    | 602 603 607 612 653 656 673 708 709     |             | CEA100M16LL   |
| C    | 605 620                                 |             | CEA0R1M50NPLL |
| C    | 606                                     |             | CEA220M6R3LL  |
| C    | 608                                     |             | CEA220M10NPLL |
| C    | 609 760                                 |             | CKSQYB472K50  |
| C    | 610 619                                 |             | CCSQCH221J50  |
| C    | 615 759                                 |             | CKSQYB102K50  |
| C    | 616                                     |             | CEA220M6R3LL  |
| C    | 617                                     |             | CEA4R7M35LL   |
| C    | 618                                     |             | CKSQYB822K50  |
| C    | 621                                     |             | CEA4R7M16NPLL |
| C    | 623                                     |             | CKSQYB272K50  |
| C    | 624                                     |             | CCSQCH221J50  |
| C    | 627                                     |             | CCSQCH220J50  |
| C    | 651 670                                 |             | CKSYF224225   |
| C    | 652                                     | 1000 μF/16V | CCH1003       |
| C    | 661 663                                 |             | CEA010M50NPLL |
| C    | 662 664 727 758 761                     |             | CKSQYB103K50  |
| C    | 665                                     |             | CEAR22M50NPLL |
| C    | 667 668 669 713 714 721 724 752 756 757 |             | CKSQYB103K50  |
| C    | 671 672                                 |             | CSZAR68M35L   |
| C    | 675 676                                 |             | CEA2R2M50LL   |
| C    | 677 679                                 |             | CCSQSL681J50  |
| C    | 678                                     |             | CKSYB473K25   |
| C    | 680                                     |             | CKDYB681K50   |
| C    | 701 710 712 725 726                     |             | CSYA6R8M6R30S |
| C    | 702                                     |             | CSYA220M6R30S |
| C    | 706 707                                 |             | CCSQCH470J50  |
| C    | 717 718                                 |             | CEA470M6R3LL  |
| C    | 722 723                                 |             | CEA330M6R3LL  |
| C    | 751                                     | 2200 μF/16V | CCH-123       |
| C    | 754 755                                 |             | CCSQCH300J50  |

|      | CDX-M100/UC<br>~000581 | CDX-M100/UC<br>000582~ | CDX-M100/EW<br>000001~ |
|------|------------------------|------------------------|------------------------|
| C373 | CCDCH220J50            | CCSQCH220J50           | CCSQCH220J50           |
| C666 | CQFA333J50L            | CKSYB333K25            | CKSYB333K25            |

Unit Number :  
Unit Name : Carriage Mechanism P.C.Board

| Mark | Circuit Symbol & No. | Part Name            | Part No. |
|------|----------------------|----------------------|----------|
| ** M | 831                  | Motor Unit(Spindle)  | CXM1018  |
| ** M | 832                  | Motor Unit(Carriage) | CXA2133  |
| ** S | 831                  | Switch(Home)         | CSN-094  |

Unit Number :  
Unit Name : Clamp Motor P.C.Board

| Mark | Circuit Symbol & No. | Part Name          | Part No. |
|------|----------------------|--------------------|----------|
| ** M | 803                  | Motor Unit (Clamp) | CXA2147  |
| ** S | 801 803              | Switch(End, Float) | CSN1004  |

# CDX-M100

Unit Number :  
Unit Name : ELV. Select P.C.Board

| Mark | Circuit Symbol & No. | Part Name         | Part No. |
|------|----------------------|-------------------|----------|
| ** S | 806 807              | Switch(STBY, EJP) | CSN1004  |
| P    | 801                  | Photo-Interrupter | ON1113   |

Unit Number :  
Unit Name : Tray Select P.C.Board

| Mark | Circuit Symbol & No. | Part Name         | Part No. |
|------|----------------------|-------------------|----------|
| P    | 802                  | Photo-Interrupter | ON2160   |

Unit Number :  
Unit Name : Driver P.C.Board

## MISCELLANEOUS

| Mark  | Circuit Symbol & No. | Part Name          | Part No.   |
|-------|----------------------|--------------------|------------|
| ** IC | 801                  |                    | BAG238A    |
| ** IC | 802                  |                    | TC4025BP   |
| ** IC | 803                  |                    | BAG209     |
| ** Q  | 801                  |                    | 2SD1273A   |
| ** Q  | 802                  |                    | DTA124EL   |
| ** Q  | 803 804              |                    | DTC124EL   |
| * D   | 801                  |                    | RD11JSB1   |
| * D   | 802                  |                    | RD5R1EB2   |
| ** VR | 801                  | Semi-fixed 22kΩ(B) | VRTB6VS223 |

## RESISTORS

| Mark | Circuit Symbol & No. | Part Name | Part No.     |
|------|----------------------|-----------|--------------|
| R    | 801                  |           | RD1/4PS821JL |
| R    | 802                  |           | RD1/4PS331JL |
| R    | 803 804 805          |           | RD1/4PS222JL |
| R    | 806 807 808          |           | RD1/4PS470JL |
| R    | 809                  |           | RD1/4PS622JL |
| R810 |                      |           | RD1/4PS681JL |
| R811 |                      |           | RD1/4PS471JL |
| R812 |                      |           | RD1/4PS222JL |

## CAPACITORS

| Mark | Circuit Symbol & No. | Part Name | Part No.     |
|------|----------------------|-----------|--------------|
| C    | 801                  |           | CSYA220M100S |
| C    | 802                  |           | CGDYX104M25  |
| C    | 803                  |           | CKDYB103K50  |

## Miscellaneous Parts List

| Mark | Circuit Symbol & No. | Part Name                           | Part No. |
|------|----------------------|-------------------------------------|----------|
|      |                      | Pick Up Unit                        | CGY1006  |
| ** M | 801                  | Motor Unit(Tray)                    | CXA2146  |
| ** M | 802                  | Motor Unit(ELV.)                    | CXA2145  |
| ** S | 802 804 805 808      | Switch<br>(MAG-1, MAG-2, TOUT, TIN) | CSN1004  |

**12. PACKING METHOD**

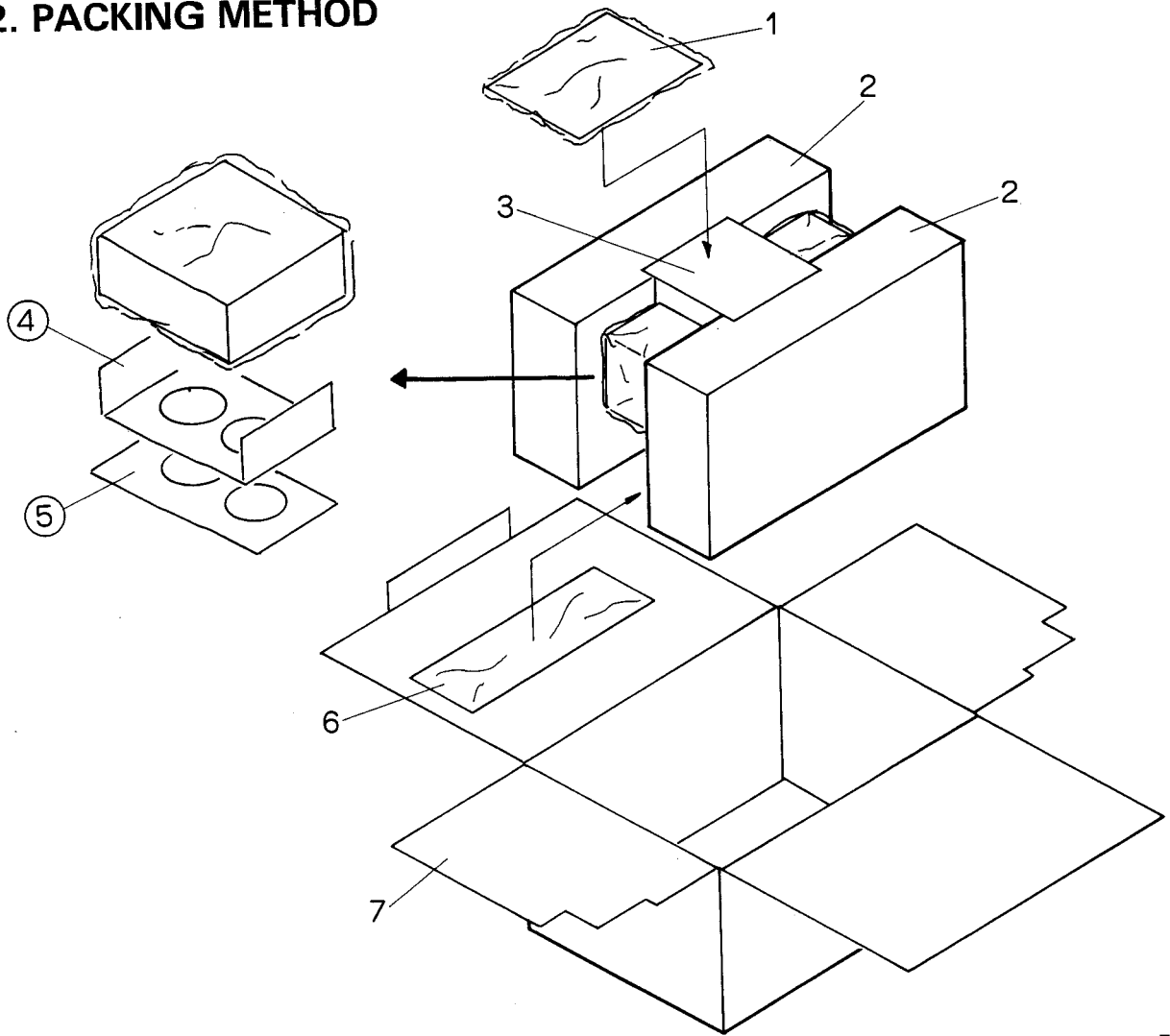

Fig. 83

• Parts List

| Mark | No. | Part No. | Description         | Mark | No.   | Part No.     | Description     |
|------|-----|----------|---------------------|------|-------|--------------|-----------------|
|      | 1   | CRD1115  | Owner's Manual (UC) |      | 6-1   | CDE1789      | Cord (13P) (UC) |
|      |     | CRD1116  | Owner's Manual (EW) |      |       | CDE1865      | Cord (13P) (EW) |
|      |     |          | Card                |      | 6-2   | CDE1790      | Cord (1P)       |
|      |     |          | Cushion             |      | 6-3   | CDE1791      | Cord (2P)       |
|      | 2   | CHP1116  | Styrofoam           |      | 6-4   | CEA1255      | Screw Assy      |
|      | 3   | PXA1104  | Magazine (UC)       |      | 6-4-1 | CBA1069      | Screw           |
|      |     | PXA1050  | Magazine (EW)       |      | 6-4-2 | HMB60P500FZK | Screw           |
|      | 4   |          | Angle               |      | 6-4-3 | HMF40P080FZK | Screw           |
|      | 5   |          | Base                |      | 6-4-4 | NF60FZK      | Nut             |
|      | 6   | CEA1303  | Accessory Assy (UC) |      | 6-4-5 | NR60FMC      | Nut             |
|      |     | CEA1311  | Accessory Assy (EW) |      | 7     | CHG1418      | Carton (UC)     |
|      |     |          |                     |      |       | CHG1419      | Carton (EW)     |



### 13. NAME OF PARTS AND THEIR FUNCTIONS

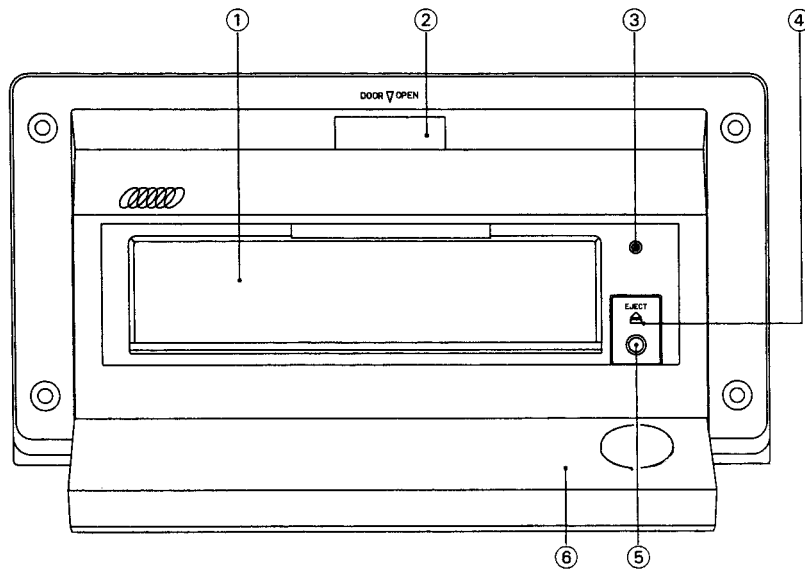

Fig. 84

① **Compact disc magazine insertion hole**

② **Door open button**

Pressing this button opens the door ⑥.

③ **Clear button**

If the power will not come on, or the compact disc player will not operate when the button on the compact disc controller is pressed, or if the compact disc controller display is incorrect, press this button on the player with the tip of a pencil to restore normal operation. Always press the clear button on the compact disc controller, too, after pressing this button.

④ **Eject button**

Pressing this button ejects the magazine.

⑤ **Power indicator**

This lamp comes on when the power is turned on.

⑥ **Door**

Be sure never to leave the door open.

## 14. CONNECTION

- Be sure to connect the ground lead (black) to the vehicle body or some other metal part. If the ground lead is not properly connected, noise may occur or the player or compact disc controller may not operate correctly.

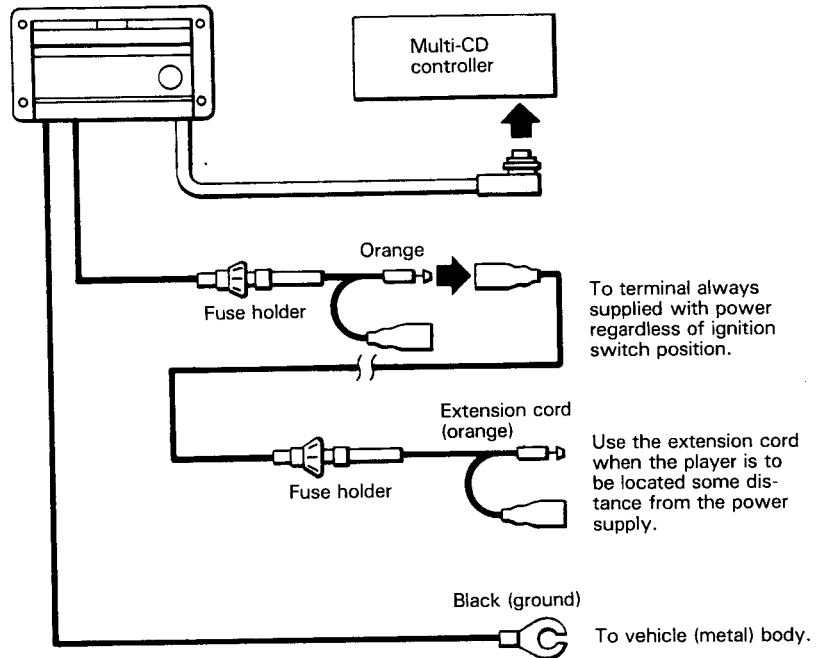

Fig. 85