

# Service Manual

**ORDER I  
ART-590**
**NON SWITCHING AMP  
STEREO AMPLIFIER**

# A-9

**MODEL A-9 COMES IN SIX VERSIONS DISTINGUISHED AS FOLLOWS:**

Type	Voltage	Remarks
KU	120V only	U.S.A. model
S	110V, 120V, 220V and 240V (Switchable)	General export model
S/G	110V, 120V, 220V and 240V (Switchable)	U.S. Military model
HE	220V and 240V (Switchable)	Europe model
HB	220V and 240V (Switchable)	United Kingdom model
KC	120V only	Canada model

- This service manual is applicable to the HE and HB types.
- Ce manuel d'instruction se réfère au mode de réglage, en français.
- Este manual de servicio trata del método de ajuste escrito en español.

## CONTENTS

1. SPECIFICATIONS .....	2
2. FRONT PANEL FACILITIES .....	3
3. BLOCK DIAGRAM .....	6
4. CIRCUIT DESCRIPTIONS .....	7
5. PARTS LOCATION .....	10
6. PACKING .....	12
7. P.C. BOARDS CONNECTION DIAGRAM .....	13
8. EXPLODED VIEW .....	21
9. SCHEMATIC DIAGRAM .....	25
10. ELECTRICAL PARTS LIST .....	29
11. ADJUSTMENTS .....	34
RÉGLAGE .....	35
AJUSTE .....	36

**PIONEER ELECTRONIC CORPORATION** 4-1, Meguro 1-Chome, Meguro-ku, Tokyo 153, Japan  
**U.S. PIONEER ELECTRONICS CORPORATION** 85 Oxford Drive, Moonachie, New Jersey 07074, U.S.A.  
**PIONEER ELECTRONIC (EUROPE) N.V.** Lutichagen-Haven 9, 2030 Antwerp, Belgium  
**PIONEER ELECTRONICS AUSTRALIA PTY. LTD.** 178-184 Boundary Road, Braeside, Victoria 3195, Australia

YH © D.E.C. 1980

Printed in Japan

# 11. AJUPECIFICATIONS

## Amplificador

### Carrier Section

- Girar con VR4 (der)
- Sin interrupción, min., at 8 ohms from 20 Hertz to 20,000 Hertz with no more than 0.003% total harmonic distortion.

Punto de conexión	Continuous Power Output at 1 kHz (both channels driven)
aj	T.H.D. 0.003%, 8 ohms ..... 120 watts per channel
VF	Total Harmonic Distortion (20 Hertz to 20,000 Hertz, 8 ohms, from TUNER)
	continuous rated power output ..... No more than 0.003%
	55 watts per channel power output .. No more than 0.003%
	Intermodulation Distortion (50 Hertz:7,000 Hertz = 4:1, 8 ohms, from TUNER)
	continuous rated power output ..... No more than 0.005%
	55 watts per channel power output .. No more than 0.003%
	Damping Factor (20 Hertz to 20,000 Hertz, 8 ohms) ..... 60
	Input Sensitivity/Impedance
	PHONO MM ..... 2.5 mV/50 kilohms
	cartridge load capacitance:
	PHONO MM ..... 100, 200, 300, 400 pF
	PHONO MC ..... 0.1 mV/100 ohms
	cartridge load resistance:
	PHONO MC ..... 33, 100 ohms
	TUNER, AUX, TAPE PLAY 1, 2 ..... 150 mV/50 kilohms
	Phono Overload Level (T.H.D. 0.0015%, 1,000 Hz)
	PHONO MM ..... 250 mV
	PHONO MC ..... 10 mV
	Output Level/Impedance
	TAPE REC 1, 2 ..... 150 mV/50 kilohms
	Speaker ..... A/OFF, B/OFF (4~16 Ω)
	Frequency Response
	PHONO (RIAA Equalization) ..... 20 Hz to 20,000 Hz±0.2 dB
	TUNER, AUX, TAPE PLAY 1, 2 ..... 5 Hz to 200,000 Hz±3 dB
	Tone Control
	BASS ..... +10 dB/-10 dB (100 Hz, 50 Hz)
	Turnover Frequency: 400 Hz/200 Hz
	TREBLE ..... +10 dB/-10 dB (10 kHz, 20 kHz)
	Turnover Frequency: 2.5 kHz/5 kHz
	Filter
	LOW (SUBSONIC) ..... 20 Hz (12 dB/oct.)
	Loudness Contour (Volume control set at -40 dB position)
	..... +6 dB (100 Hz), +3 dB (10 kHz)
	Hum and Noise (IHF, short circuited A network)
	PHONO MM ..... 90 dB
	PHONO MC ..... 74 dB
	TUNER, AUX, TAPE PLAY 1, 2 ..... 110 dB
	Hum and Noise (DIN, continuous rated power output/50 mW)
	PHONO MM ..... 80 dB/68 dB
	PHONO MC ..... 75 dB/70 dB
	TUNER, AUX, TAPE PLAY 1, 2 ..... 95 dB/70 dB
	Muting ..... -20 dB

## Miscellaneous

### Power Requirements

HE, HB models	..... 220/240 V (switchable), 50/60 Hz
S, S/G models	..... 110/120/220/240 V (switchable), 50/60 Hz

### Power Consumption

HE, HB models	..... 820 W (max.)
S, S/G models	..... 300 W (max.)

Dimensions	..... 420 (W) x 150 (H) x 430 (D) mm
	16-9/16 (W) x 5-15/16 (H) x 16-15/16 (D) in

Weight (without package)	..... 16 kg (35 lb 4 oz)
--------------------------	--------------------------

## Furnished Parts

Operating Instructions	..... 1 (HE model only; 2)
Fuse (S, S/G models only)	..... 1 (10 A or 5 A)

*\*Measured pursuant to the Federal Trade Commission's Trade Regulation rule on Power Output Claims for Amplifiers.*

*NOTE: Specifications and the design subject to possible modifications without notice due to improvements.*

## 2. FRONT PANEL FACILITIES

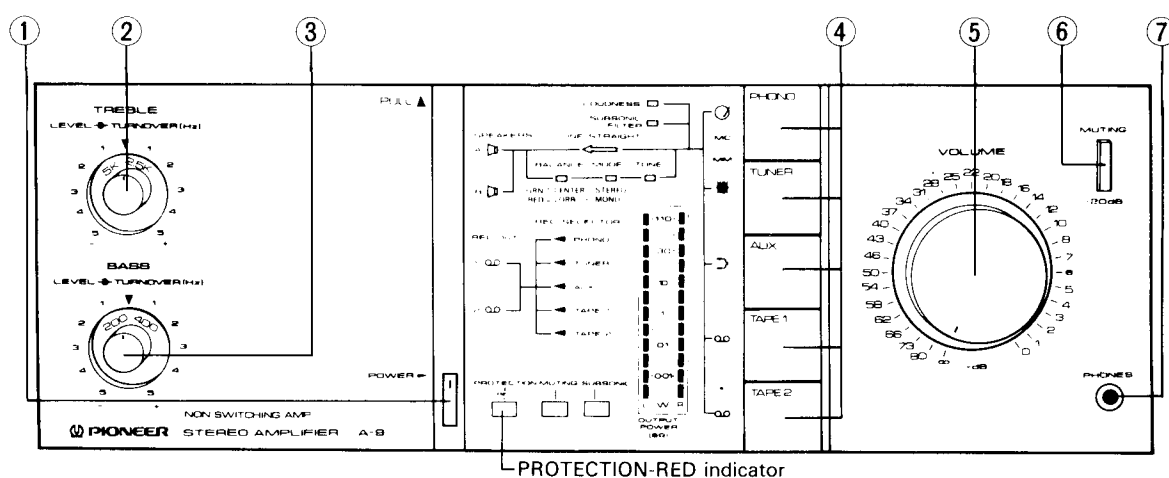

### ① POWER SWITCH

Power is supplied to the stereo amplifier as soon as this switch is depressed to the ON position.

The power is turned off when the switch is released to the OFF position.

Immediately after the power switch has been set to ON, the muting circuit is actuated, the PROTECTION-RED indicator lights up red/and about 6 seconds after this when the muting circuit has been released, this indicator goes from red to green.

### ② TREBLE CONTROL

This is used to adjust the treble (high-frequency range) sound. When it is rotated clockwise from the "▼" position with the LINE STRAIGHT-OFF switch depressed (the TONE, MODE and BALANCE indicators light), the level of sound above the frequency selected by the TREBLE-TURNOVER switch is emphasized. Conversely, when the control is rotated counterclockwise from the "▼" position, the level of sound above the frequency selected by the TREBLE-TURNOVER switch is attenuated.

### ③ BASS CONTROL

This is used to adjust the bass (low-frequency range) sound. When it is rotated clockwise from the "▼" position with the LINE STRAIGHT-OFF switch depressed (the TONE, MODE and BALANCE indicators light), the level of sound below the frequency selected by the BASS-TURNOVER switch is emphasized. Conversely, when the control is rotated counterclockwise from the "▼" position, the level of sound below the frequency selected by the BASS-TURNOVER switch is attenuated.

### ④ FUNCTION SWITCHES

These are used to select the sound source. At the left of each switch is a function indicator (pictographic) which lights when the corresponding switch has been depressed. This indicates that the lighted function has been selected.

**PHONO:** Depress for playing records on a turntable connected to the PHONO jacks.

**TUNER:** Depress for listening to a program on a tuner connected to the TUNER jacks.

**AUX:** Depress for listening to the sound from a stereo component connected to the AUX jacks.

**TAPE 1:** Depress to listen to a tape in a tape deck connected to the TAPE-1 jacks or to monitor a recording.

**TAPE 2:** Depress to listen to a tape in a tape deck connected to the TAPE-2 jacks or to monitor a recording.

#### NOTE:

Depress only one FUNCTION switch at a time. The desired program source may not be selected if two or more switches are depressed at the same time.

### ⑤ VOLUME CONTROL

This is used to adjust the volume of sound heard through the speakers or headphones. The scale gives the attenuation when the rated output power is 0 dB. No sound is heard when it is set to the "∞" position. To increase the volume, rotate this control slowly clockwise (↻).

### ⑥ MUTING -20 dB SWITCH

The volume is attenuated by -20 dB when this switch is depressed to the ON position (MUTING indicator lights). The switch can be used effectively when the stylus descends onto the record during record play, when the sound is to be turned down temporarily and when you want to adjust the sound precisely as you listen to a program source under low sound level conditions.

### ⑦ PHONES JACK

Connect the plug on your headphones to this jack when listening to a program in private.

To listen to a program through the headphones, release both the SPEAKERS A and B switches.

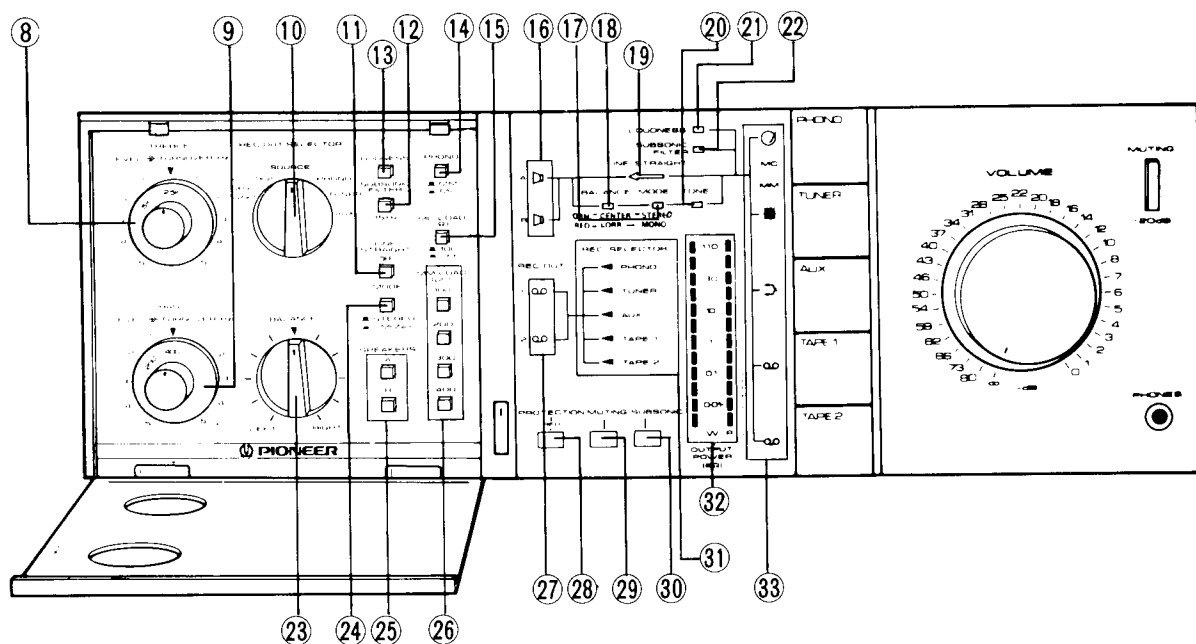

### ⑧ TREBLE-TURNOVER selector switch

This is used to select the frequency at which the TREBLE control starts to have an effect on the tone quality when it is used for adjustment.

**2.5 k:** Allows the frequency band above 2.5 kHz to be adjusted.

**5 k:** Allows the frequency band above 5 kHz to be adjusted.

### ⑨ BASS-TURNOVER SELECTOR SWITCH

This is used to select the frequency at which the BASS control starts to have an effect on the tone quality when it is used for adjustment.

**400:** Allows the frequency band below 400 Hz to be adjusted.

**200:** Allows the frequency band below 200 Hz to be adjusted.

### ⑩ REC OUT SELECTOR SWITCH

This is used to select the output signal which is fed out to the TAPE REC jacks.

**COPY 2 ▶ 1:** The output signal is fed out from the TAPE 2 PLAY jacks to the TAPE 1 REC jacks (when dubbing a tape from TAPE 2 to TAPE 1).

**COPY 1 ▶ 2:** The output signal is fed out from the TAPE 1 PLAY jacks to the TAPE 2 REC jacks (when dubbing a tape from TAPE 1 to TAPE 2).

**SOURCE:** The output signal of the program source (PHONO, TUNER, AUX, etc.) selected by the FUNCTION switch is fed out to the TAPE 1 REC and TAPE 2 REC jacks.

**PHONO:** The output signal from the PHONO jacks is fed out to the TAPE 1 REC and TAPE 2 REC jacks.

**TUNER:** The output signal from the TUNER jacks is fed out to the TAPE 1 REC and TAPE 2 REC jacks.

**AUX:** The output signal from the AUX jacks is fed out to the TAPE 1 REC and TAPE 2 REC jacks.

### ⑪ LINE STRAIGHT-OFF SWITCH

When this switch is released to the ON position (the LINE STRAIGHT indicator lights), the signal from the input jacks is directly sent to the power amplifier input without passing through the tone control circuit. When this switch is depressed to the OFF position, the input signal's tone quality can be adjusted with the tone controls.

### ⑫ SUBSONIC 15 Hz FILTER SWITCH

Depressing this switch to the ON position actuates the subsonic filter with the 15 Hz cutoff frequency. Once the SUBSONIC FILTER indicator has lighted, it means that noise has been detected. Depress the SUBSONIC FILTER switch. This filter serves to attenuates frequencies lower than 15 Hz with a 12 dB/oct slope and, therefore, it can be used to suppress the ultra-low-range noise which is generated by record warp and other factors. This noise cannot actually be heard by the ear but it can cause cross modulation distortion and even speaker damage. Use this switch when required during record play.

### ⑬ LOUDNESS SWITCH

The bass and treble sound is emphasized when this switch is depressed to the ON position (LOUDNESS indicator lights) under low volume listening conditions.

When the volume of sound is low, the capability of the ear to pick up the bass and treble sound drops off, compared with high volume listening conditions. The LOUDNESS switch compensates for this characteristic of the ear. The bass and treble are emphasized when the switch is set to ON and the sound comes alive even when the volume is low.

**14 PHONO MM/MC SELECTOR SWITCH**

This switch is set to the position that corresponds to the type of cartridge being used when listening to a record on a turntable connected to the PHONO jacks.

- **MM:** Set here when using an MM cartridge.
- **MC:** Set here when using an MC cartridge.

**NOTE:**

Some MC cartridges on the market have the same high output power as MM cartridges. Consult the instructions accompanying the cartridge.

**15 MC LOAD ( $\Omega$ ) SWITCH**

This switch is set to the position that corresponds to the output impedance of the MC (moving coil) cartridge being used for record play.

**16 SPEAKERS A/B INDICATORS**

These light when one of the SPEAKERS switches has been depressed.

**17 MODE INDICATOR**

This lights up green (STEREO) or red (MONO) in accordance with the selected position of the MODE selector.

**18 BALANCE INDICATOR**

Depending on the position of the BALANCE control, this lights up green (when the control is at the CENTER position) or red (when it is rotated LEFT or RIGHT position).

**19 LINE STRAIGHT INDICATOR**

This lights when the LINE STRAIGHT-OFF switch has been released to ON in place of the BALANCE, MODE and TONE indicators.

**20 TONE INDICATOR**

This lights when the tone control circuitry has been actuated.

**21 LOUDNESS INDICATOR**

This lights when the LOUDNESS switch has been set to ON.

**22 SUBSONIC FILTER INDICATOR**

This lights when the SUBSONIC FILTER switch has been set to ON.

**23 BALANCE CONTROL**

This is used to adjust the balance of the sound from the left and right channels. When rotated clockwise from its center position, the volume of the left (L) channel is reduced; when rotated counterclockwise, the volume of the right (R) channel is reduced.

To adjust the balance, first set the BALANCE control to its center position, set the MODE selector to MONO and rotate the control so that the sound seems to be coming from the midpoint between the left and right speakers.

**24 MODE SELECTOR**

This is used to select the mode.

- **STEREO:** Set here for ordinary stereo listening.
- **MONO:** Set here to mix the left and right channel stereo input signals and hear them in mono through both the left and right speakers.

**25 SPEAKERS SWITCHES**

These are used to select the speakers through which you will listen to the sound. When one of the switches is depressed, the corresponding speaker indicator will light to indicate that the selected speakers are now working.

- A:** The sound is heard from the speakers connected to the speaker A terminals.
- B:** The sound is heard from the speakers connected to the speaker B terminals.

No sound will be heard when SPEAKERS A and B switches are both released. This is the position at which the sound can be heard through the headphones.

**26 MM LOAD ( $\mu$ F) SWITCH**

This switch is set to the position that corresponds to the designated load capacitance of the MM (moving magnet) cartridge being used for record play.

**27 REC OUT 1, 2 INDICATORS**

These indicate the tape deck which is recording in accordance with the position selected by the REC OUT SELECTOR switch.

**28 PROTECTION-RED INDICATOR**

This lights in red or green, depending on the operating mode of the power protection circuit.

**29 MUTING INDICATOR**

This lights in accordance with the position of the MUTING -20 dB switch.

**30 SUBSONIC DETECTION INDICATOR**

This lights upon detection of ultra-low-frequency noise components generated by record warp and other factors or any other noise contained in the program source. When it has lighted, depress the SUBSONIC FILTER switch to the ON position. The indicator goes off at the ON position.

**31 REC SELECTOR INDICATOR**

This indicates the program source (PHONO, TUNER, AUX, etc.) being recorded in accordance with the position of the REC OUT SELECTOR switch.

**32 OUTPUT POWER 8  $\Omega$  METER**

This indicates the output level when speakers with an 8-ohm impedance are connected to the speaker terminals. L is for the left channel and R for the right channel.

**33 FUNCTION INDICATORS**

The indicator corresponding to the selected FUNCTION switch lights.

# 3. BLOCK DIAGRAM

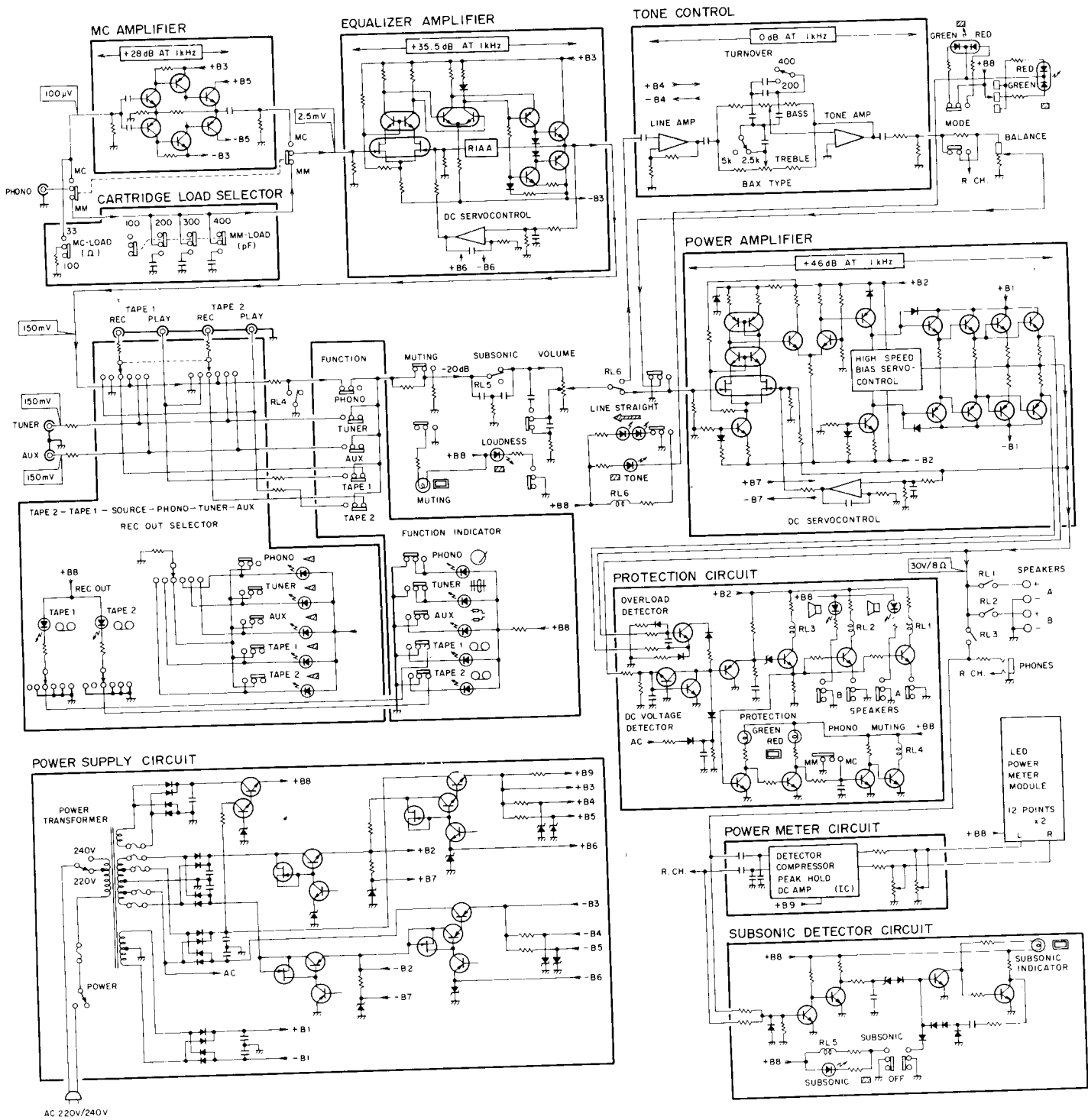

## 4. CIRCUIT DESCRIPTIONS

### 4.1 AMPLIFIER SECTION

#### Cartridge Load Selector

When the PHONO MM switch is placed to the ON position, the MM LOAD (C) switch may be positioned to provide four different levels of input capacitance (100pF, 200pF, 300pF, 400pF) in the phono input circuit. The input impedance of the equalizer amplifier is set at  $50k\Omega/100pF$ , and operating the MM LOAD (C) switch places capacitors in parallel configuration in the input circuit.

When the PHONO MC switch is placed to the ON position, operating the MC LOAD (R) switch places input resistance into the phono input circuit to provide two different levels ( $33\Omega$ ,  $100\Omega$ ) of cartridge loading.

#### MC Amplifier

To provide compatibility with low-output moving-coil cartridges, the MC amp is a flat-response voltage amplifier with a gain of 28dB. This amplifier is switched into the before stage of the equalizer amplifier by the PHONO MC switch being placed to the ON position. Circuitry is completely symmetrical, and consists of 3-stages with direct coupling. The first stage uses ultra-low noise NPN and PNP transistors, and an S/N ratio of 74dB ( $100\mu V$  input, IHF-A) is attained.

#### Equalizer Amplifier

The first stage is a cascade connected differential amp using an ultra-low noise twin FET and NPN twin transistor. The second stage differential amp, in combination with the modified current mirror of the third stage serves to cancel even-harmonic distortion components, and the output stage is a class A configuration symmetrical complementary SEPP.

A DC servocontrol circuit is also built into the equalizer amplifier. This circuit serves to hold DC area gain of the equalizer amplifier to less than 1, so that even when an extremely low frequency is input into the amp, it is practically eliminated from the output. This circuit also functions to minimize DC drift at the output mid-point. Output is returned to the input stage through the integrating amp (consisting of operational amplifier IC  $\mu PC741C$ ), holding circuit gain in the DC area to less than 1.

Using FETs in the first stage, combined with the DC servocontrol function eliminates the need for coupling capacitors between inputs and outputs, and there is no sound degradation due to capacitors.

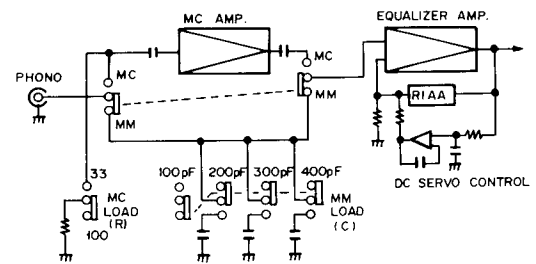

Fig. 4-1 Cartridge load selector circuit

#### Tone Control

Tone control is by a BAX type tone control circuit with a turnover frequency selector. To improve S/N ratio, a line amp has been added to the before stage. Both line amp and tone amp use operational amplifiers (IC  $\mu PC4558DX$ ).

An attenuator is used in the output circuit to equalize the level with the line straight circuit. This brings the total gain of the tone control section to 0dB.

#### Line Straight Circuit

When the LINE STRAIGHT OFF switch is in the LINE STRAIGHT position, the tone control circuit (including line amp), MODE (STEREO/MONO) switch, and BALANCE control are bypassed, and the signal circuit is directly coupled from the VOLUME control to the power amp for pure DC amplification.

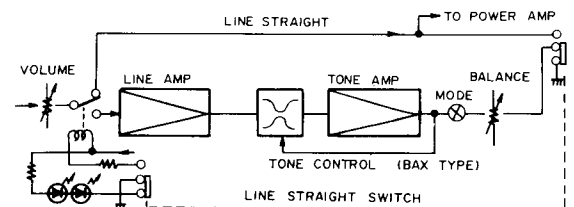

Fig. 4-2 Line straight circuit

## Power Amplifier

The first stage is a cascade connected differential amplifier using a low noise twin FET and an NPN twin transistor, and the load circuit is the current mirror type. The power stage is a 3-stage Darlington arrangement, with the final stage a parallel SEPP.

Bias voltage is supplied to the power stages through the high speed bias servocontrol circuit. The B class push-pull power stage alternately drives the N and P channels during each half-cycle, and the high speed bias servocontrol circuit controls the bias voltage so that the idle channel of the power stage is maintained in the active region. (Refer to the section on the High Speed Bias Servocontrol Circuit for operational details.)

The power amplifier has a built in DC servocontrol circuit functioning to reduce gain in the DC area to less than 1, so that even if a DC input were present, it would, for all practical purposes, not appear at the output. This circuit also functions to hold center-point DC drift to a minimum. The signal is returned from the output stage to the input stage via the integrating amp (constructed of an operational amplifier), and circuit gain in the DC area is held to less than 1.

The use of FETs in the first stage, combined with the DC servocontrol circuit eliminate the need for coupling capacitors between inputs and outputs, thereby preserving tonal quality.

### • High Speed Bias Servocontrol Circuit

By operating the power stage only within the active region (no possible cut-off) and with minimum idle current, the high speed bias servocontrol circuit prevents the generation of switching distortion and reduces heat loss.

This circuit is outlined in Fig. 4-4. When there is no signal applied to the circuit, Q1 and Q2 are almost cut off, while Q3 and Q4 will be on. The voltage across the collector and base of both of these transistors (Q3 and Q4) at this time may be disregarded. Consequently, with the power stage bias circuit consisting of 4 PN junctions formed by Q3, D3 and Q4, and VR1.

With R1 and D1 ensuring a constant flow of current, the base of Q1 and point X may be brought to the same level on an AC basis (level fluctuations due to the signal) by a simple shift in DC level. Furthermore, Q1 may be considered emitter-follower with R3 as the emitter resistance.

When the voltage across points Y and X is increased by the positive portion of the signal applied to this circuit, it becomes the input signal of this emitter-follower (Q1). Since the emitter-follower voltage gain is practically 1, a voltage more or less equal to that of the input signal (that is, the voltage increase across points Y and X) is produced at R3. And the R3 voltage is the voltage applied across the base and collector of Q3 which forms part of the power stage bias circuit. So the bias voltage applied to Q3 will be in excess by the same amount the voltage across points Y and X is increased (by positive portion of the signal) above the voltage level when no signal is being applied. Consequently, the increase in voltage across points Y and X cancels the decrease in voltage across points X and Z, thereby maintaining the idle current without cutting the PNP power stage off (noting that there actually is a slight decrease in current). For the negative portions of the signal, Q2 and Q4 are operated in the same manner, thereby preventing the NPN power stage from being cut off.

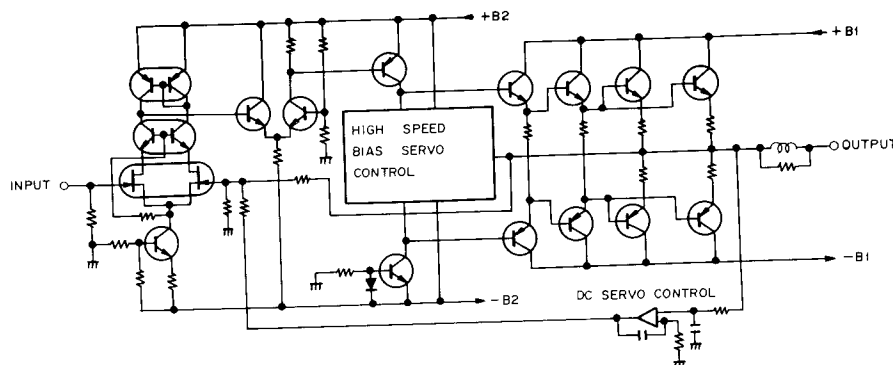

Fig. 4-3 Power amplifier circuit



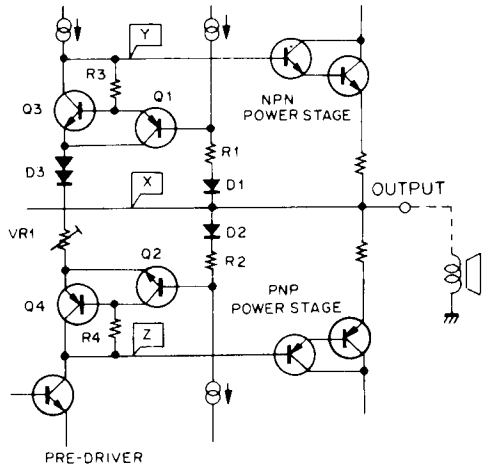

Fig. 4-4 Basic circuitry of High speed bias servocontrol circuit

### 4.2 POWER INDICATOR CIRCUIT

The A-9 indicates power output from 0.01 watt to 110 watts peak power using a 12 point LED display without range switching. The power amplifier output signal is passed through a low-pass filter, then input to IC (TA7318P-A). This IC consists of a detector circuit, compressor (40dB), and peak-hold circuit for each channel. The signal, after being processed by this IC, is input to the LED power meter module containing the voltage comparators and LED drivers. Here, the LEDs are driven (illuminated) in accordance with the input level.

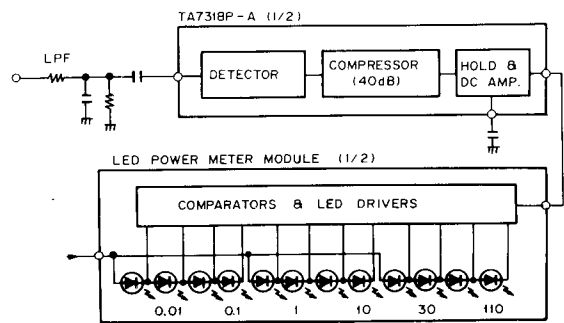

Fig. 4-5 Power indicator circuit

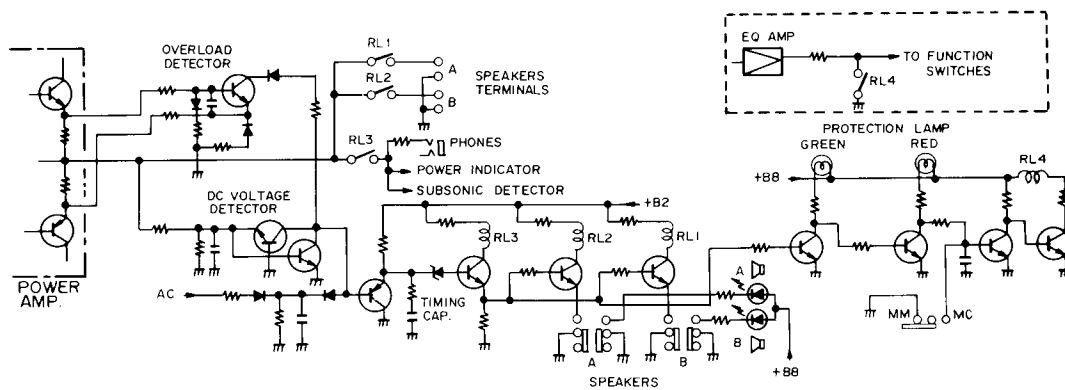

Fig. 4-6 Protection circuit

### 4.3 PROTECTION CIRCUIT

The purpose of this circuit is to protect both the speakers and the power amplifiers. The relay in the output circuit is automatically opened in any of the following cases:

1. During the "transient operations" when the power supply is turned on and off.
2. Upon detection of a DC voltage in the output circuit, caused by component failure or accident.
3. Upon detection of an overload, caused by a short circuit in the load.

# 5. PARTS LOCATION

- The  $\Delta$  mark found on some component parts indicates the importance of the safety factor of the part. Therefore, when replacing, be sure to use parts of identical designation.
- For your Parts Stock Control, the fast moving items are indicated with the marks **★★** and **★**.  
**★★ GENERALLY MOVES FASTER THAN ★.**  
 This classification shall be adjusted by each distributor because it depends on model number, temperature, humidity, etc.

## Front Panel View

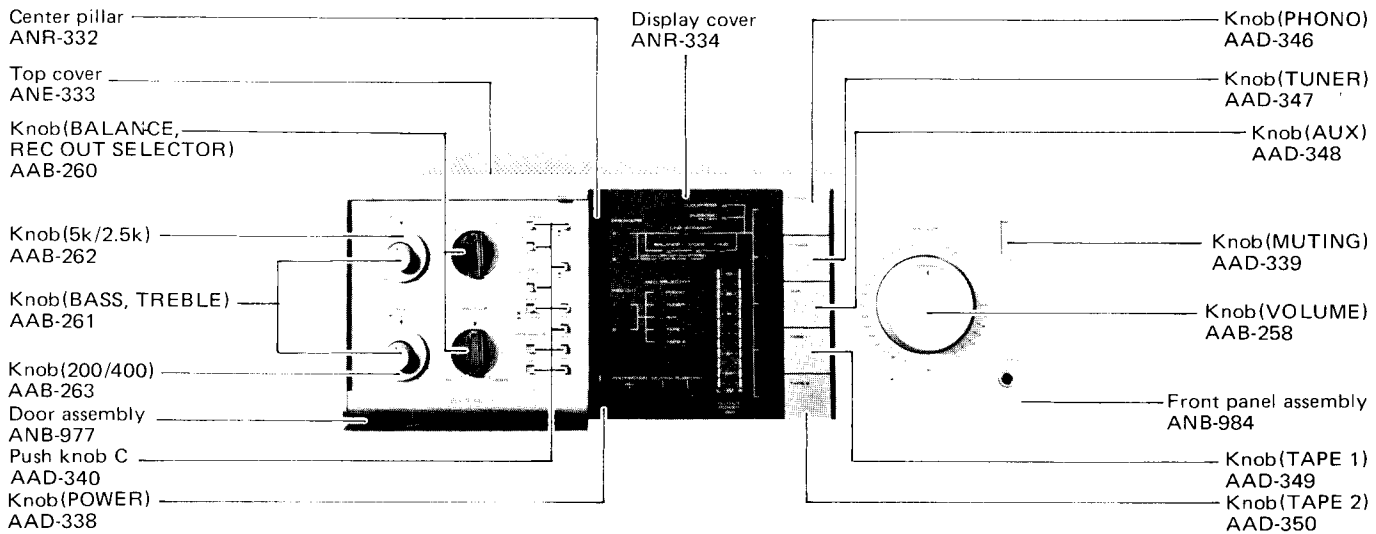

## Front View with Panel Removed

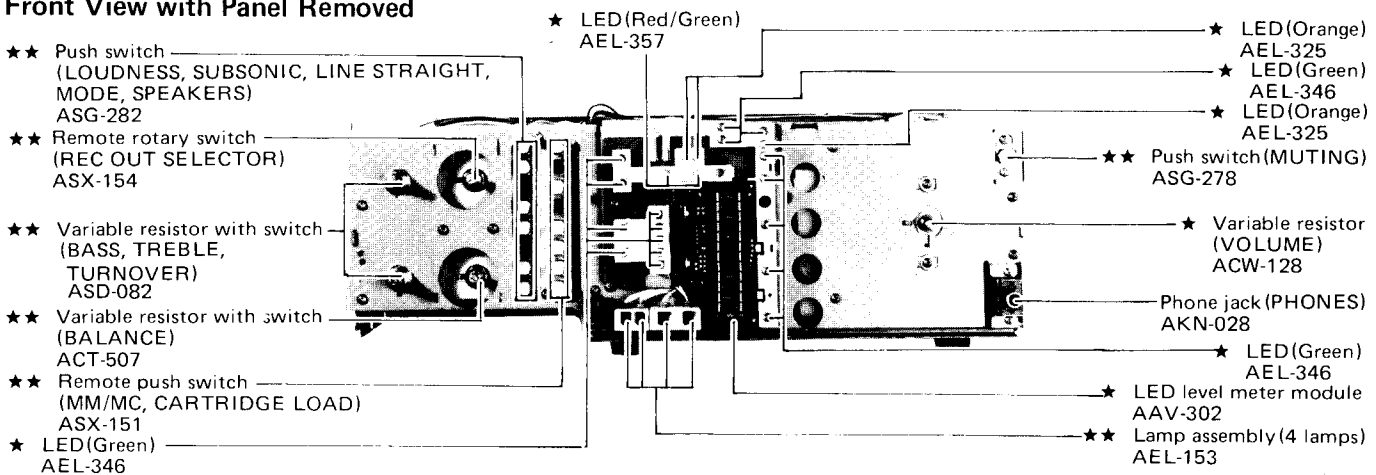

## Rear Panel View

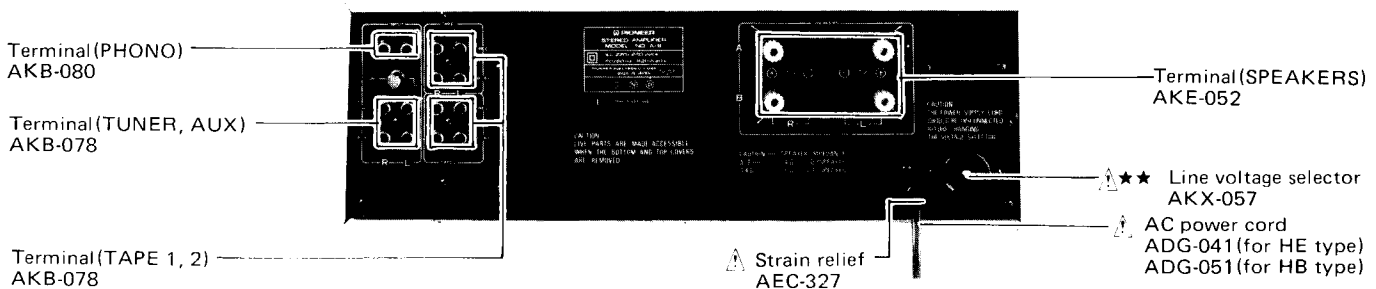

## Top View

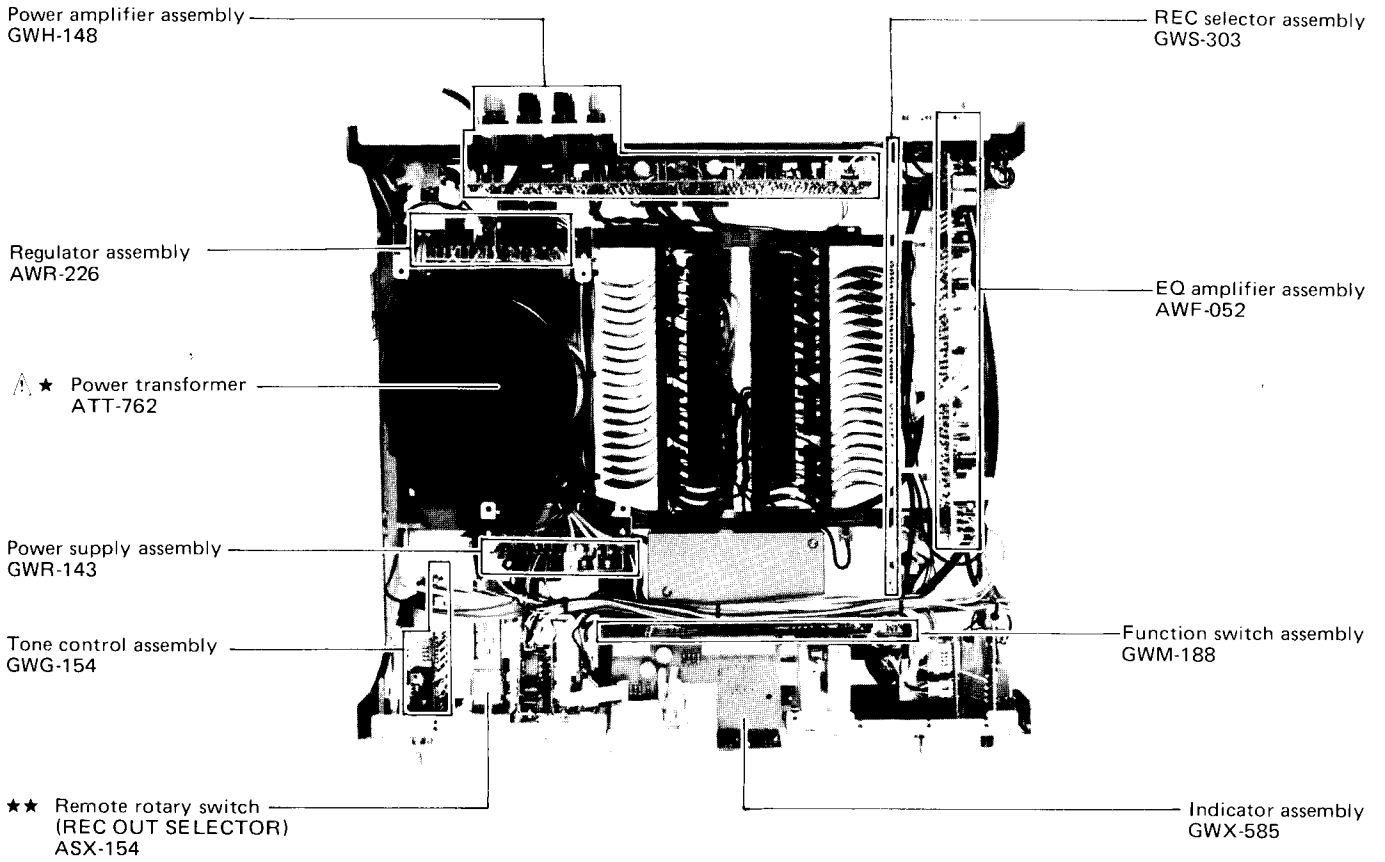

## Bottom View

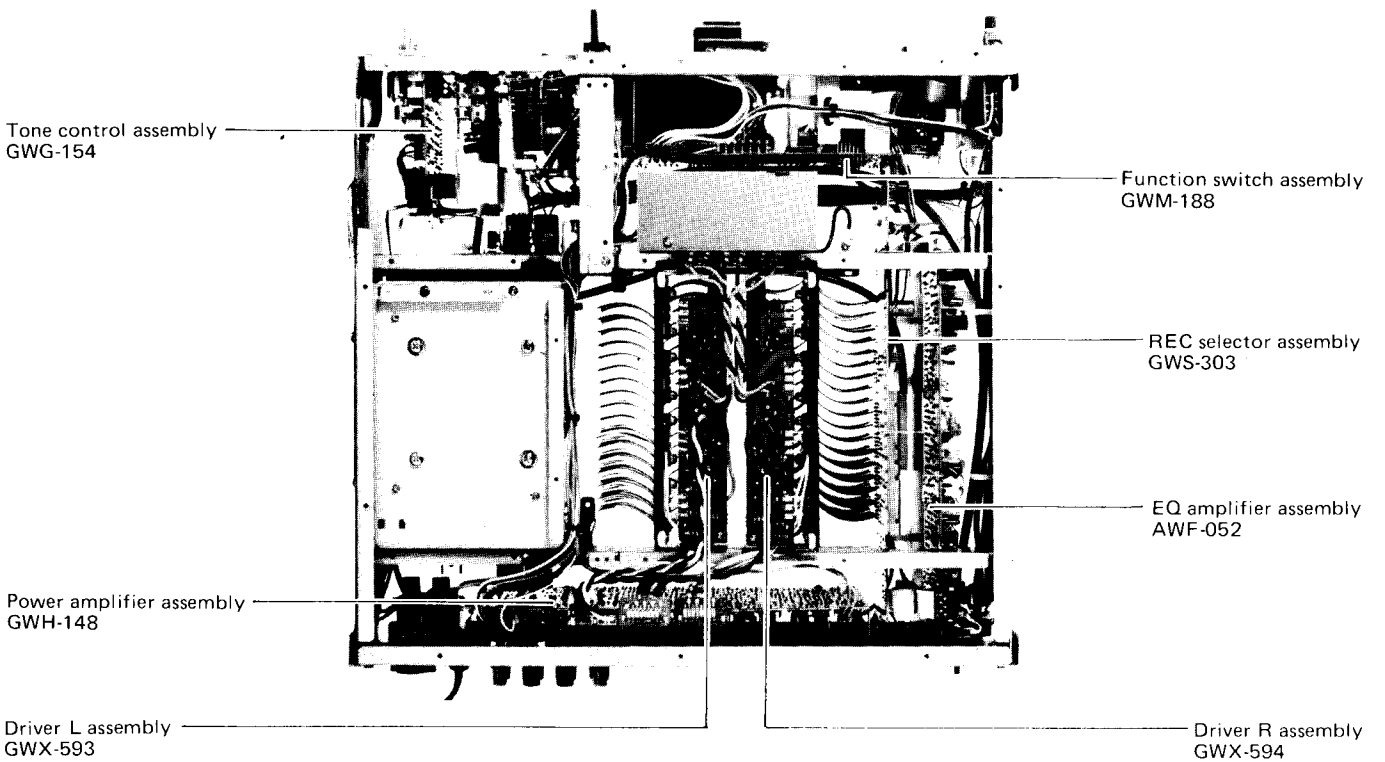

## 6. PACKING

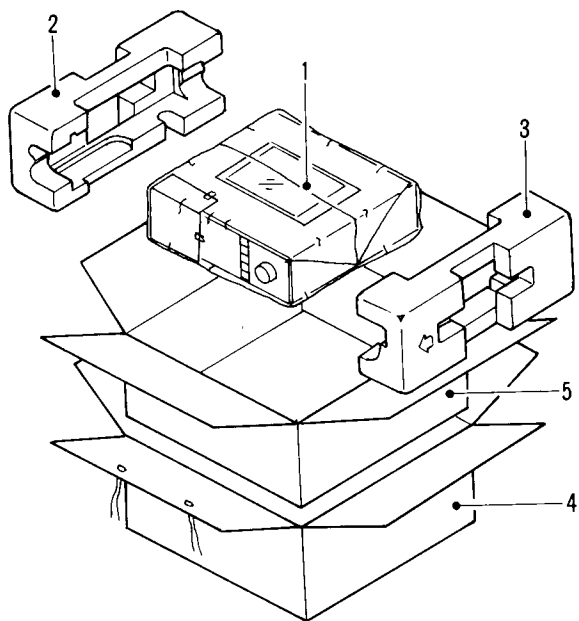

Mark	No.	Part No.	Description
	1.	ARB-399	Operating instructions (English)
		ARD-156	Operating instructions (German/French/Italian, HE type only)
	2.	AHA-279	Side pad L
	3.	AHA-280	Side pad R
	4.	AHD-874	Packing case
	5.	AHC-063	Inside packing

here  
are  
The  
h of  
y be  
stage  
ed by

ow of  
ay be  
(level  
e shift  
sidered  
tance.  
X is in-  
gnal ap-  
signal of  
itter-fol-  
ge more  
(that is  
nd X) i  
te voltag  
Q3 which  
it. So th  
ess by th  
7 and X  
nal) abo  
ng applic  
ross poi  
tage acr  
he idle c  
r stage  
decreas  
f the sig  
me mar  
age form

# 7. P.C. BOARDS CONNECTION DIAGRAM

## EQUALIZER AMP Ass'y AWF-052

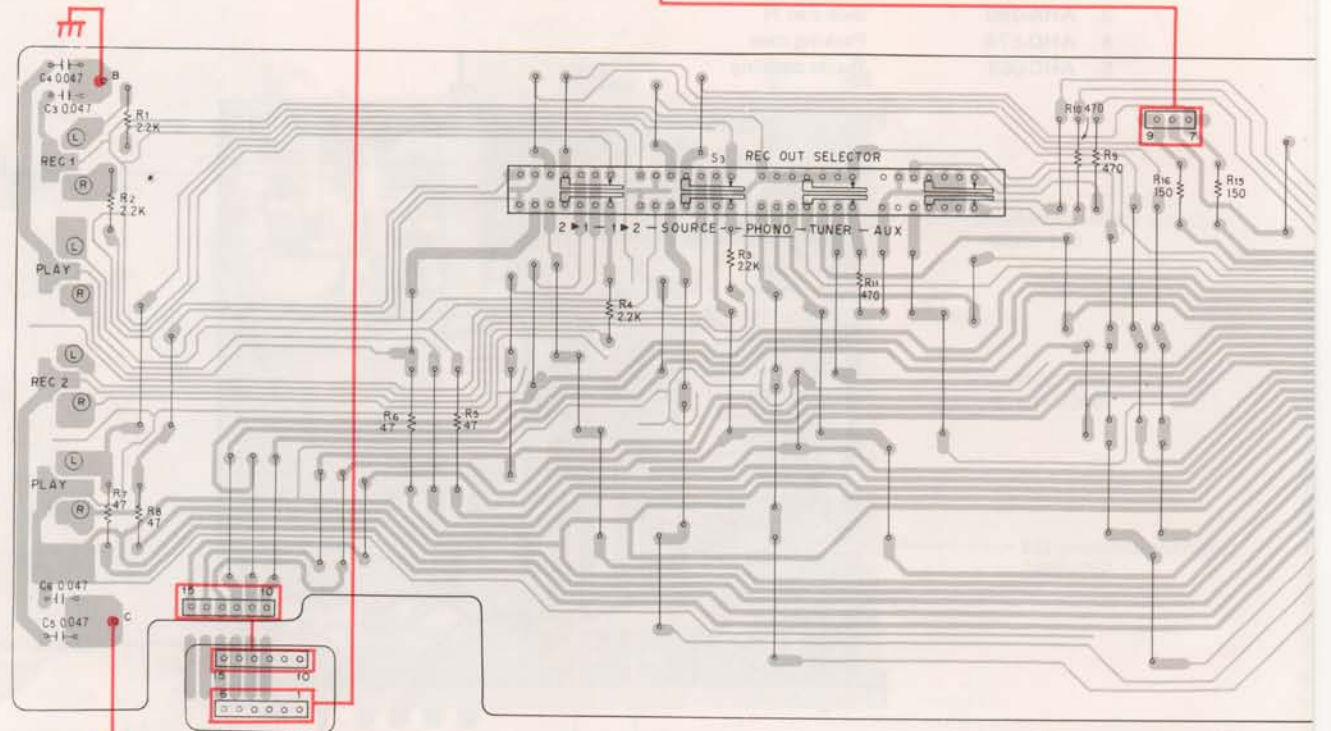
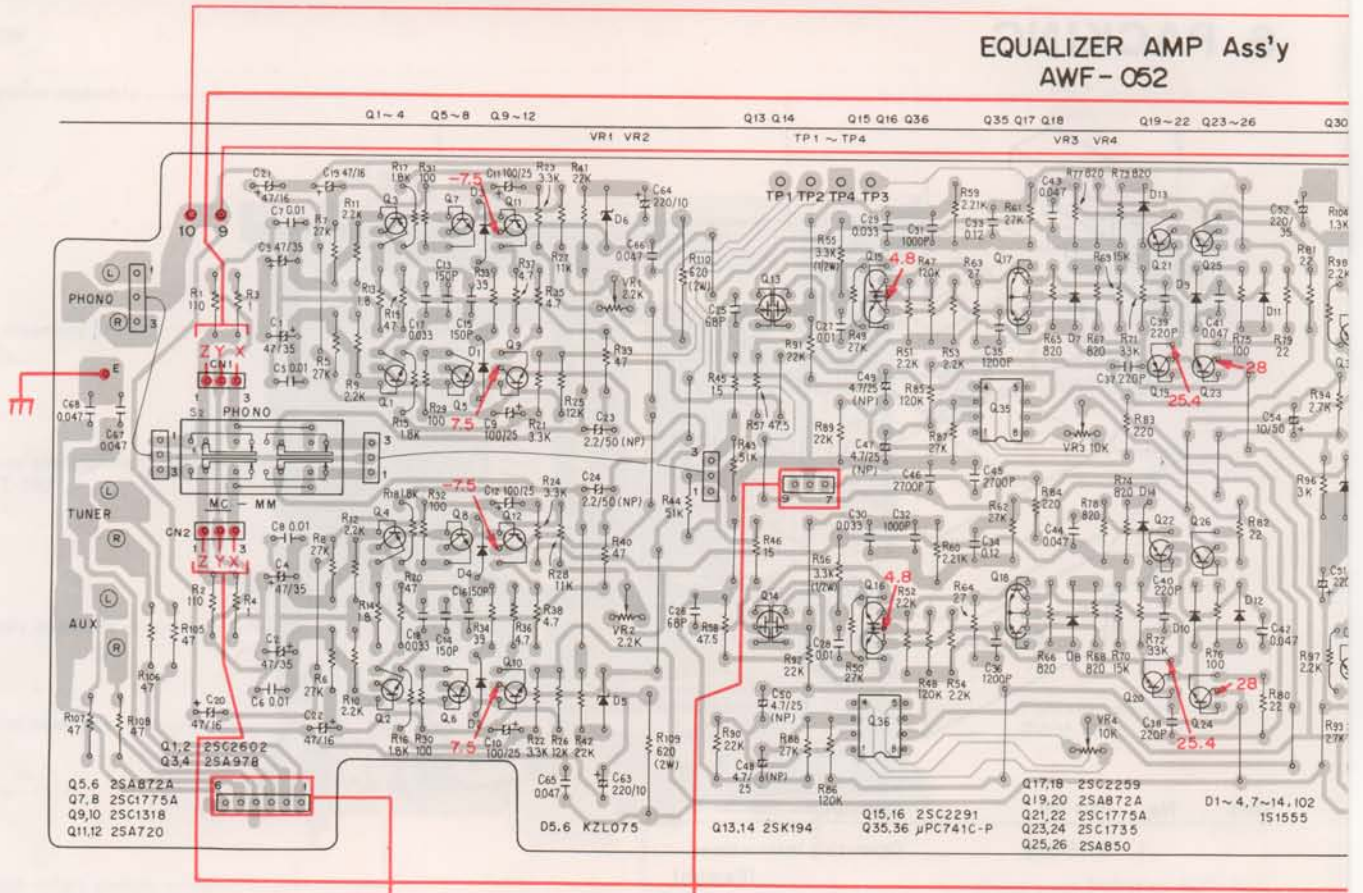

## REC SELECTOR Ass'y GWS-303

### TONE CONTROL Ass'y GWG-154

### VOLUME CONTROL Ass'y

SWIT

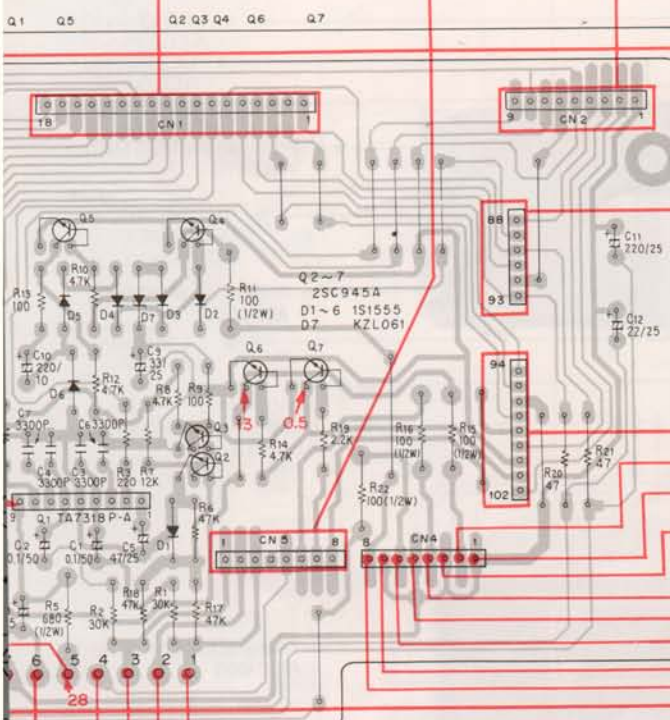
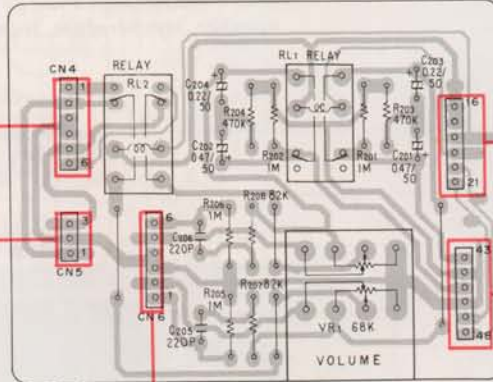
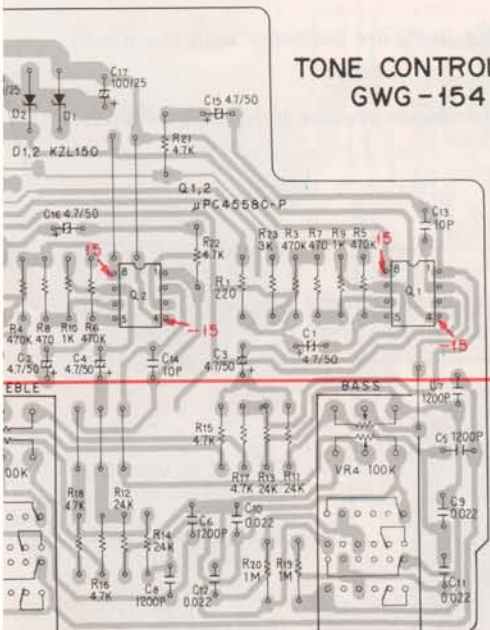

### CONNECTOR Ass'y (D)

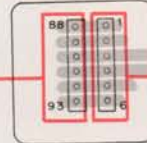

### CONNECTOR Ass'y (E)

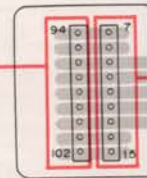

- ③ PL1 (RED)  
(PROTECTION)
- ③ PL2 (GREEN)
- ③ PL3 (MUTING)
- ③ PL4 (SUBSONIC)

PL1~4: LAMP Ass'y  
8V 50mA

### CONNECTOR Ass'y (F)

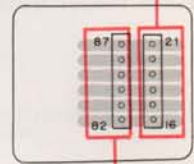

A  
B  
C

A

### SWTCH Ass'y

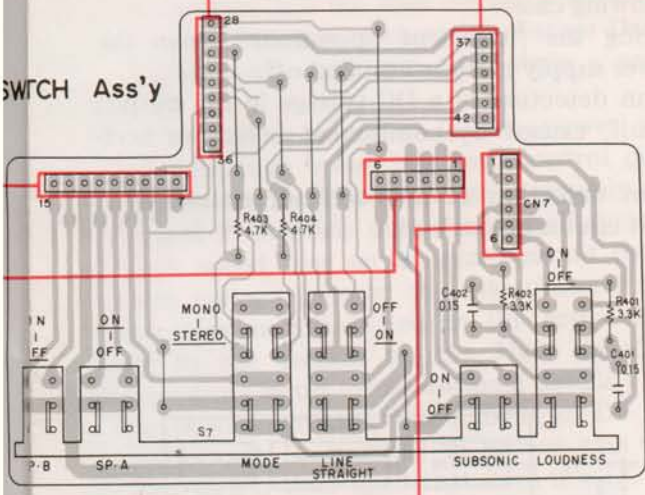

B

D  
E  
F  
G

### FM MUTING Ass'y

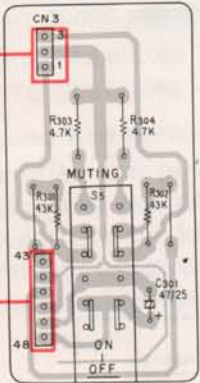

C

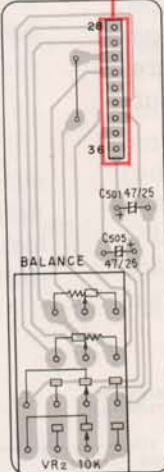

### BALANCE CONTROL Ass'y

D

### HEADPHONES JACK Ass'y

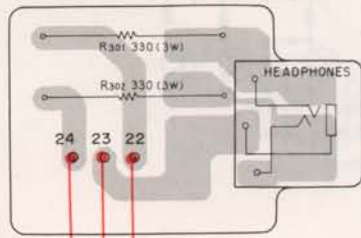

RECTOR (F)

H  
I

1

2

3

A

B

C

A

B

D

E

F

G

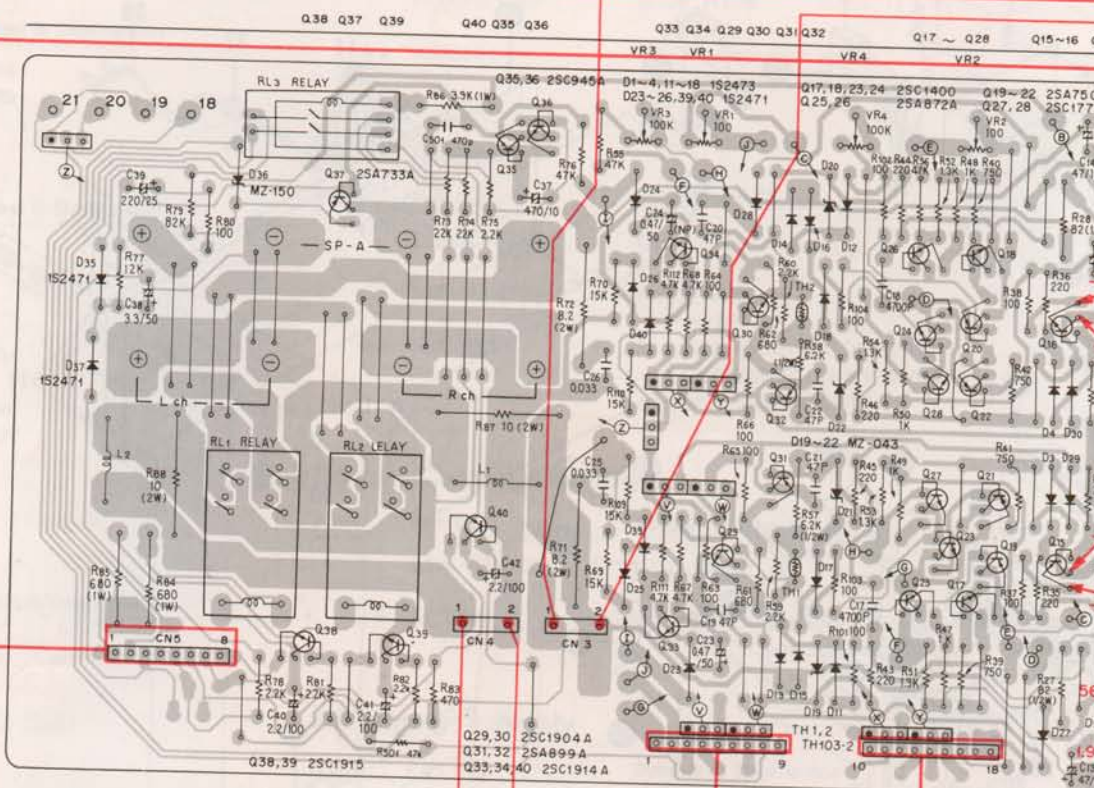

POWER AMP Ass'y GWH-148

CONNECTOR Ass'y (G)

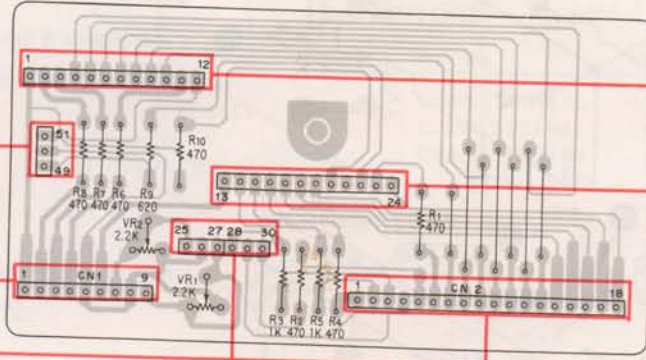

INDICATOR Ass'y GWX-585

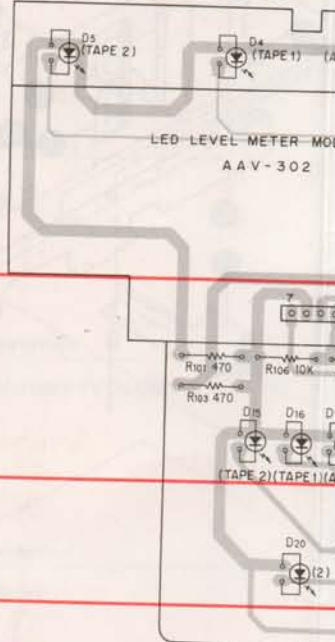

C

D

H

I

1

2

3



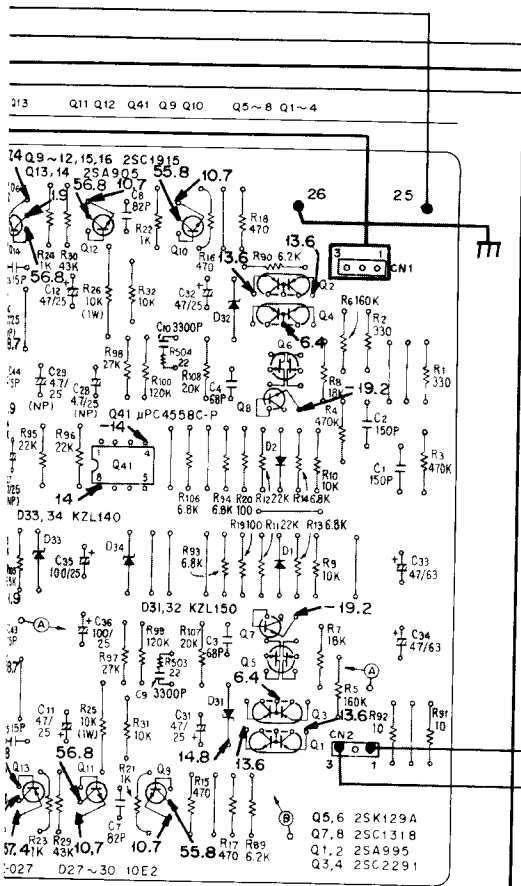

CONNECTOR Ass'y (I)

CONNECTOR Ass'y (J)

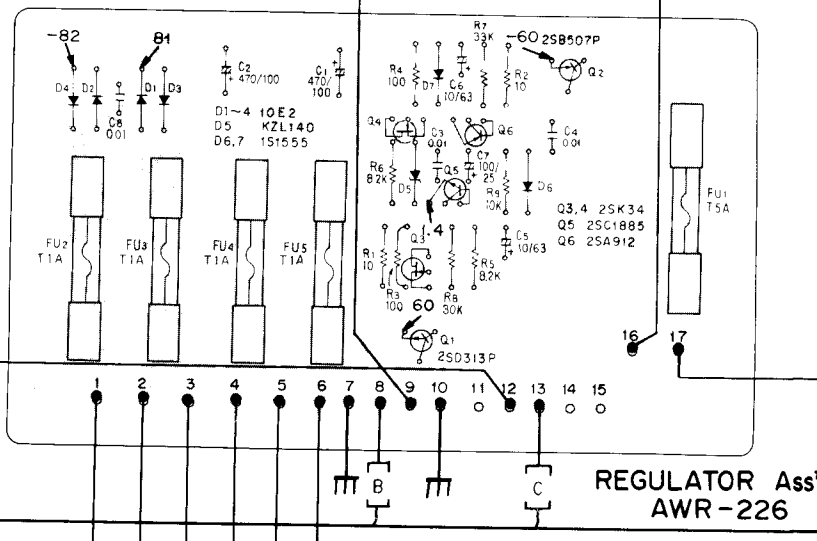
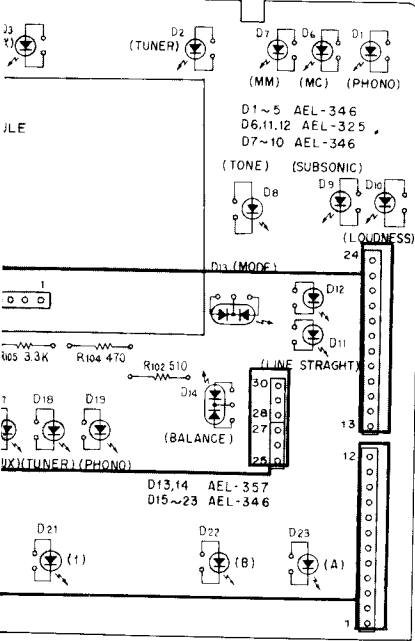
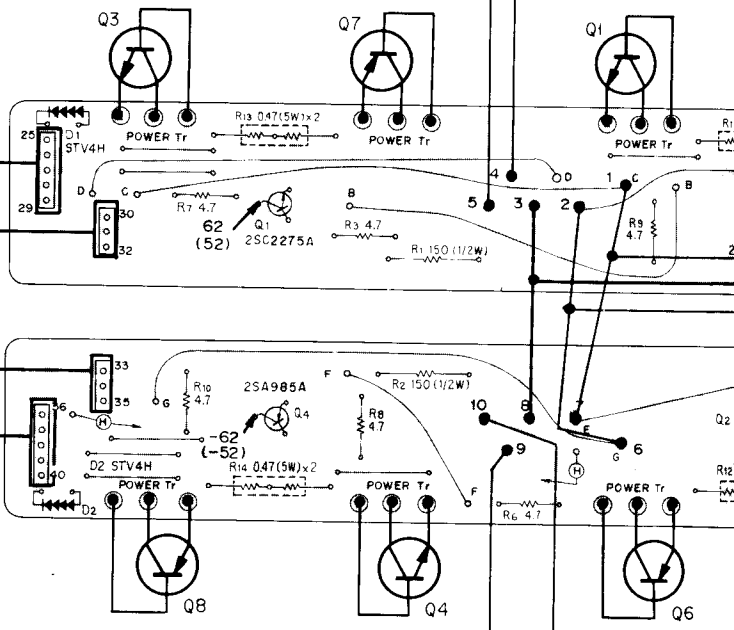

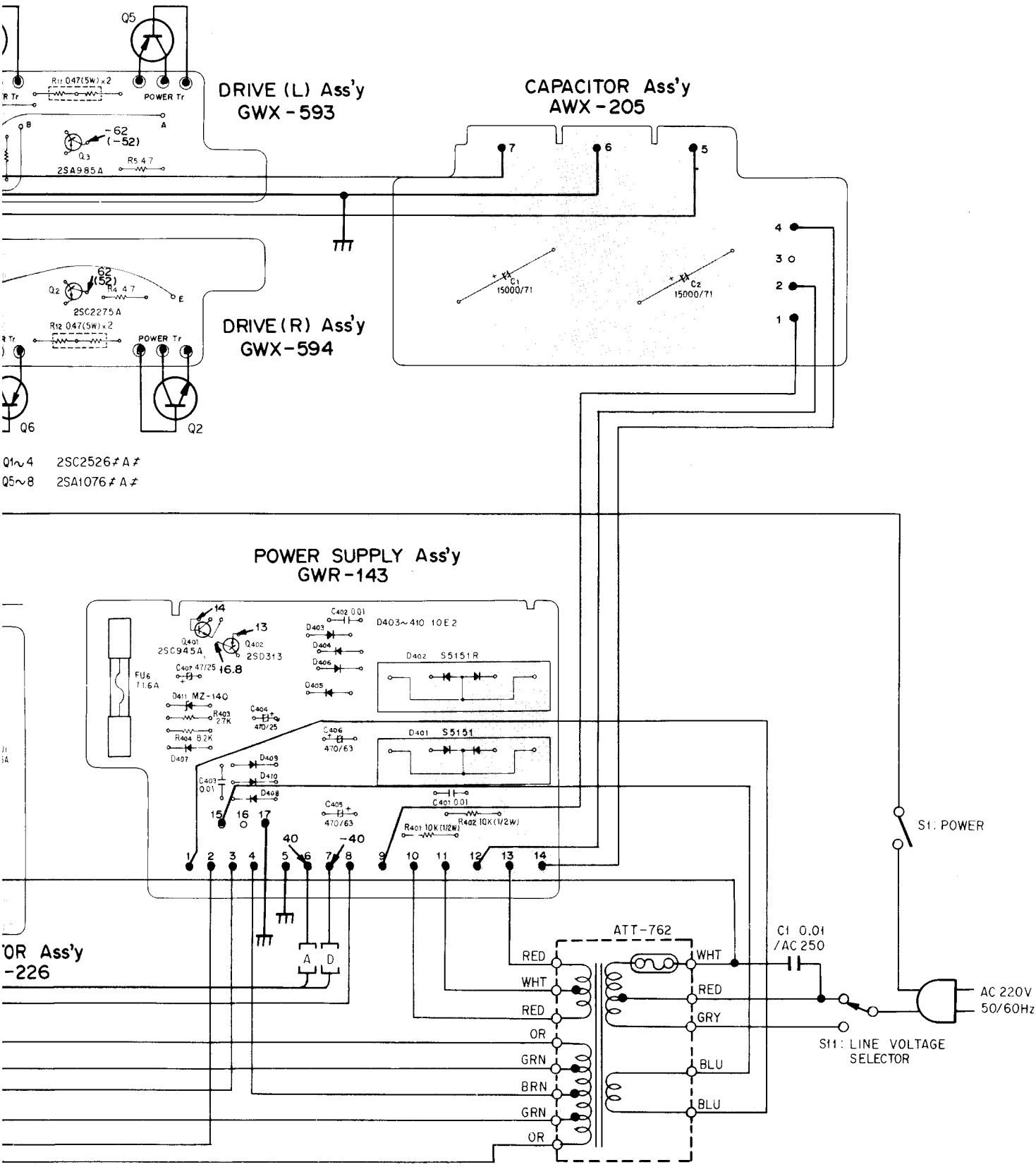

External Appearance of Transistors and ICs

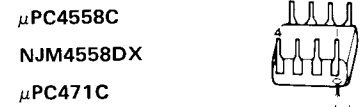
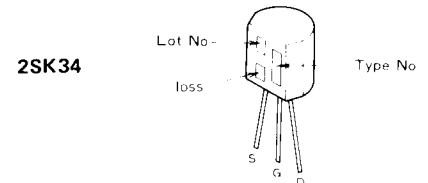
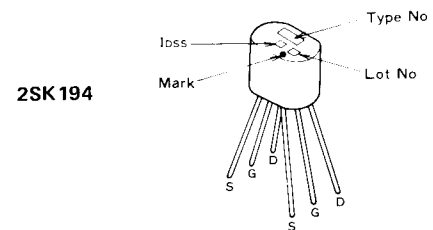
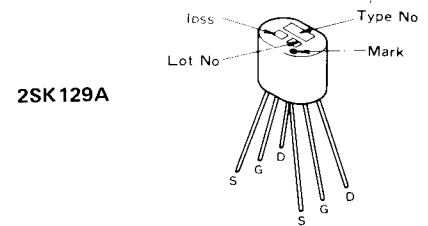
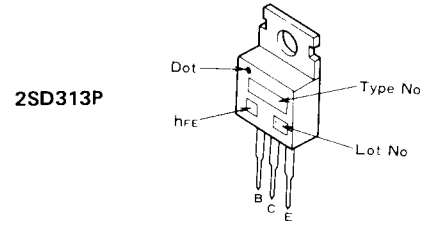
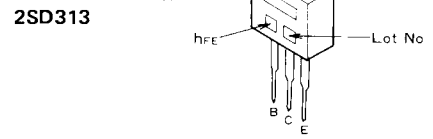
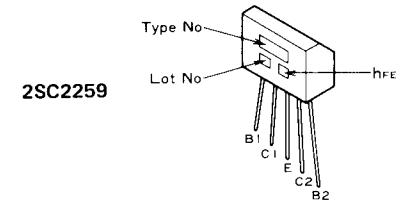
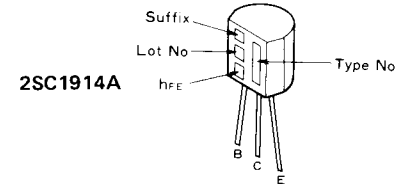
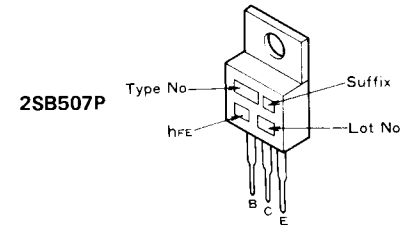
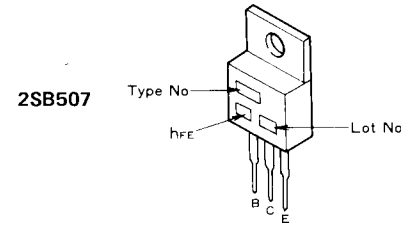
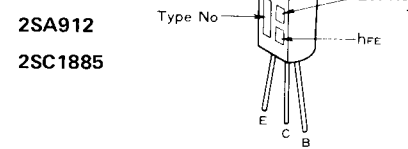
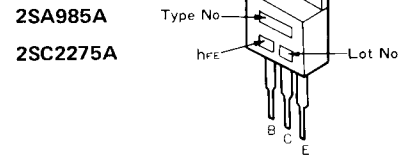
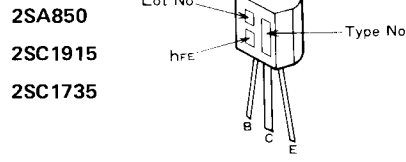
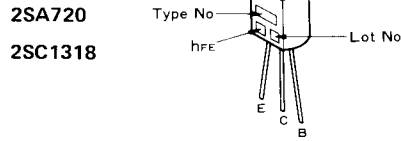
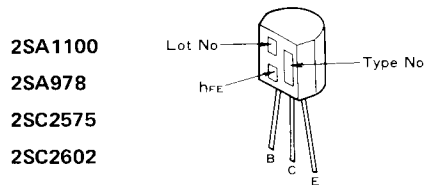
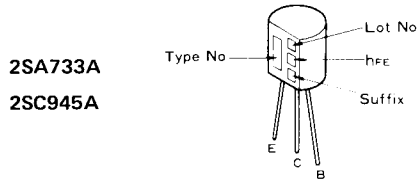
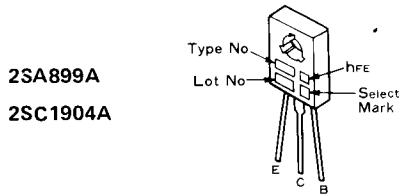
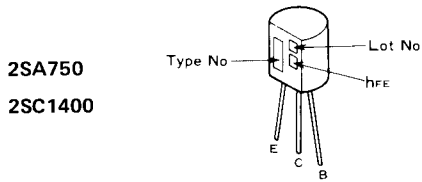
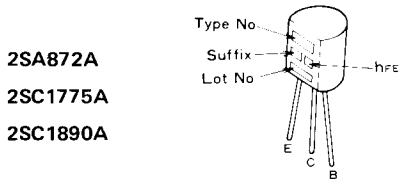
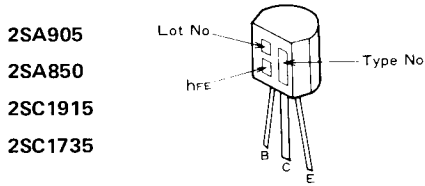
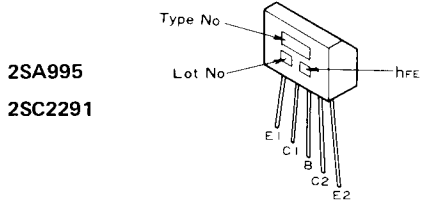
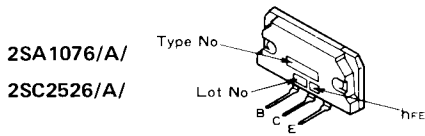

A

B

C

D

e  
ce  
re  
of  
be  
age  
by

of  
be  
level  
shift  
ered  
nce.  
is in-  
al  
ap-  
nal  
of  
er-fo-  
more  
hat is,  
(X) is  
voltage  
3 which  
. So th  
s by th  
and X  
al) abo  
; applie  
oss poi-  
ge acro  
e idle c  
stage  
decreas  
the sig  
re mar-  
ge form

# 8. EXPLODED VIEW

Exterior

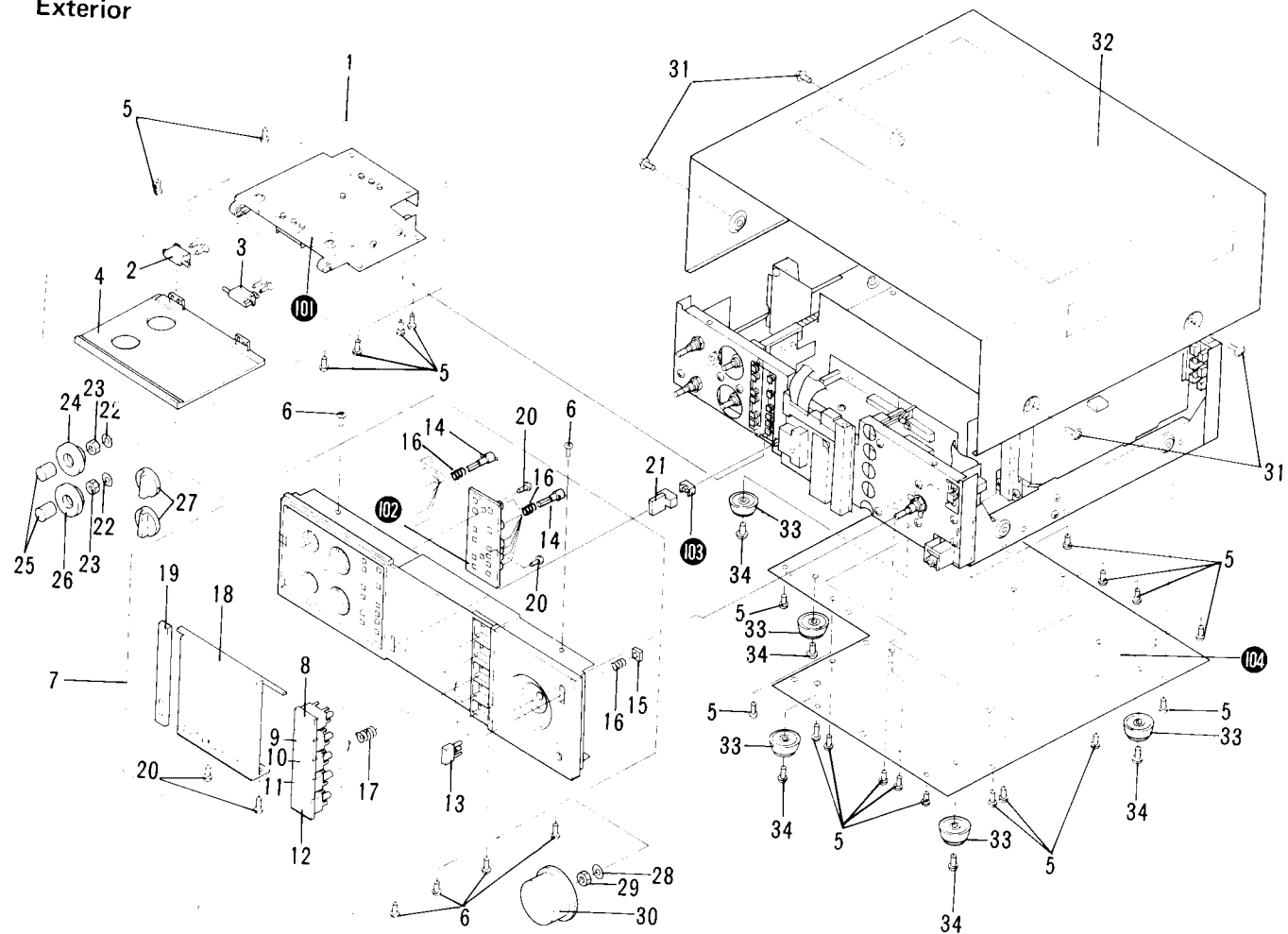













## Exterior Components

Mark	No.	Part No.	Description	Mark	No.	Part No.	Description
	1.	AXC-003	Door mechanism assembly		21.	AAD-338	Knob (POWER)
	2.	ANR-340	Hinge L		22.	WAX1F160U050	Washer 11φ
	3.	ANR-341	Hinge R		23.	NKX1FUC	Nut M11
	4.	ANB-977	Door assembly		24.	AAB-262	Knob (5k/2.5k)
	5.	VBZ30P060FMC	Screw 3x6		25.	AAB-261	Knob (BASS, TREBLE)
	6.	VBZ30P080FMC	Screw 3x8		26.	AAB-263	Knob (200/400)
	7.	ANB-984	Front panel assembly		27.	AAB-260	Knob (BALANCE, REC OUT SELECTOR)
	8.	AAD-346	Knob (PHONO)		28.	WA92F140U100	Washer 9.2φ
	9.	AAD-347	Knob (TUNER)		29.	NK90FUC	Nut M9
	10.	AAD-348	Knob (AUX)		30.	AAB-258	Knob (VOLUME)
	11.	AAD-349	Knob (TAPE 1)		31.	ABA-193	Screw
	12.	AAD-350	Knob (TAPE 2)		32.	ANE-333	Top cover
	13.	AAD-339	Knob (MUTING)		33.	AEC-083	Cabinet bumper
	14.	AAD-340	Push knob C		34.	VTZ40P120FMC	Screw 4x12
	15.	AEC-564	Knob holder		101.		Door holder
	16.	ABH-045	Coiled spring		102.		Knob spacer
	17.	ABH-069	Coiled spring		103.		Flexible ring
	18.	ANR-334	Display cover		104.		Bottom plate
	19.	ANR-332	Center pillar				
	20.	VBZ30P080FZK	Screw 3x8				

**NOTES:**

- Parts without part number cannot be supplied.
- The  mark found on some component parts indicates the importance of the safety factor of the part. Therefore, when replacing, be sure to use parts of identical designation.
- For your Parts Stock Control, the fast moving items are indicated with the marks **★★** and **★**.  
**★★ GENERALLY MOVES FASTER THAN ★.**  
This classification shall be adjusted by each distributor because it depends on model number, temperature, humidity, etc.

**Interior Components**

Mark	No.	Part No.	Description	Mark	No.	Part No.	Description
	1.	VBZ30P060FMC	Screw 3x6		101.		Side frame L
	2.	AEC-352	Nylon rivet		102.		Connector assembly
	3.	GWG-154	Tone control assembly		103.		Connector assembly
	4.	ABN-048	Washerfaced nut		104.		Holder
★★	5.	ASX-154	Remote rotary switch		105.		Remote belt
	6.	ABN-066	Union nut		106.		Balance control assembly
	7.	GWM-188	Function switch assembly		107.		Connector E assembly
	8.	ABA-261	Screw		108.		Switch assembly
	9.	ABN-046	Union nut		109.		Load selector assembly
 ★★	10.	ASG-535	Push switch(POWER)		110.		Holder
	11.	BBT30P080FZK	Screw 3x8		111.		Connector D assembly
	12.	ABA-214	Screw		112.		Remote belt
★★	13.	AEL-153	Lamp assembly(4 lamps)		113.		Volume control assembly
	14.	GWX-585	Indicator assembly		114.		Connector C assembly
	15.	VBZ30P080FMC	Screw 3x8		115.		Ground terminal 2-P
 ★★	16.	AWR-226	Regulator assembly		116.		Slide plate
 ★★	17.	AEK-015	Fuse(T5A250V)		117.		Sub-frame
 ★★	18.	AEK-402	Fuse(T1A250V)		118.		AF muting assembly
	19.	VTZ40P080FMC	Screw 4x8		119.		Headphones jack assembly
 ★	20.	ATT-762	Power transformer		120.		Switch holder
	21.	GWR-143	Power supply assembly		121.		Panel stay
 ★★	22.	AEK-405	Fuse(T1.6A250V)		122.		Lamp holder A
	23.	WS50FMC	Spring washer 5φ		123.		Lamp holder B
	24.	ABA-100	Screw 5x12		124.		P.C.B. holder B
	25.	AWX-205	Capacitors assembly		125.		P.C.B. holder C
	26.	GWX-593	Driver L assembly		126.		P.C.B. holder D
	27.	GWX-594	Driver R assembly		127.		P.C.B. holder E
	28.	ABA-258	Screw		128.		Transformer frame
 ★★	29.	2SA1076/A/-B* (2SA1076/A/-G*)	*hfe should have the same value.		129.		Shield cover A
 ★★	30.	2SC2526/A/-B* (2SC2526/A/-G*)			130.		Capacitors holder
					131.		Shield cover B
					132.		Wire saddle
	31.	AEC-488	Insulator wafer		133.		Center frame
	32.	GWS-303	REC selector assembly		134.		Heat sink
	33.	AWF-052	EQ amplifier assembly		135.		Holder A
	34.	GWH-148	Power amplifier assembly				
 ★★	35.	AKX-057	Line voltage selector		136.		Holder B
					137.		Clamp plate
	36.	VBZ30P120FMC	Screw 3x12		138.		Connector A assembly
 ★	37.	AEC-327	Strain relief		139.		Connector B assembly
 ★	38.	ADG-041	AC power cord(for HE type)		140.		P.C.B. holder A
 ★		ADG-051	AC power cord(for HB type)				
	39.	WG70FMC	Locking washer		141.		Shield plate
	40.	B71-010	Nut M7		142.		Connector assembly

1

2

3

A

B

C

D

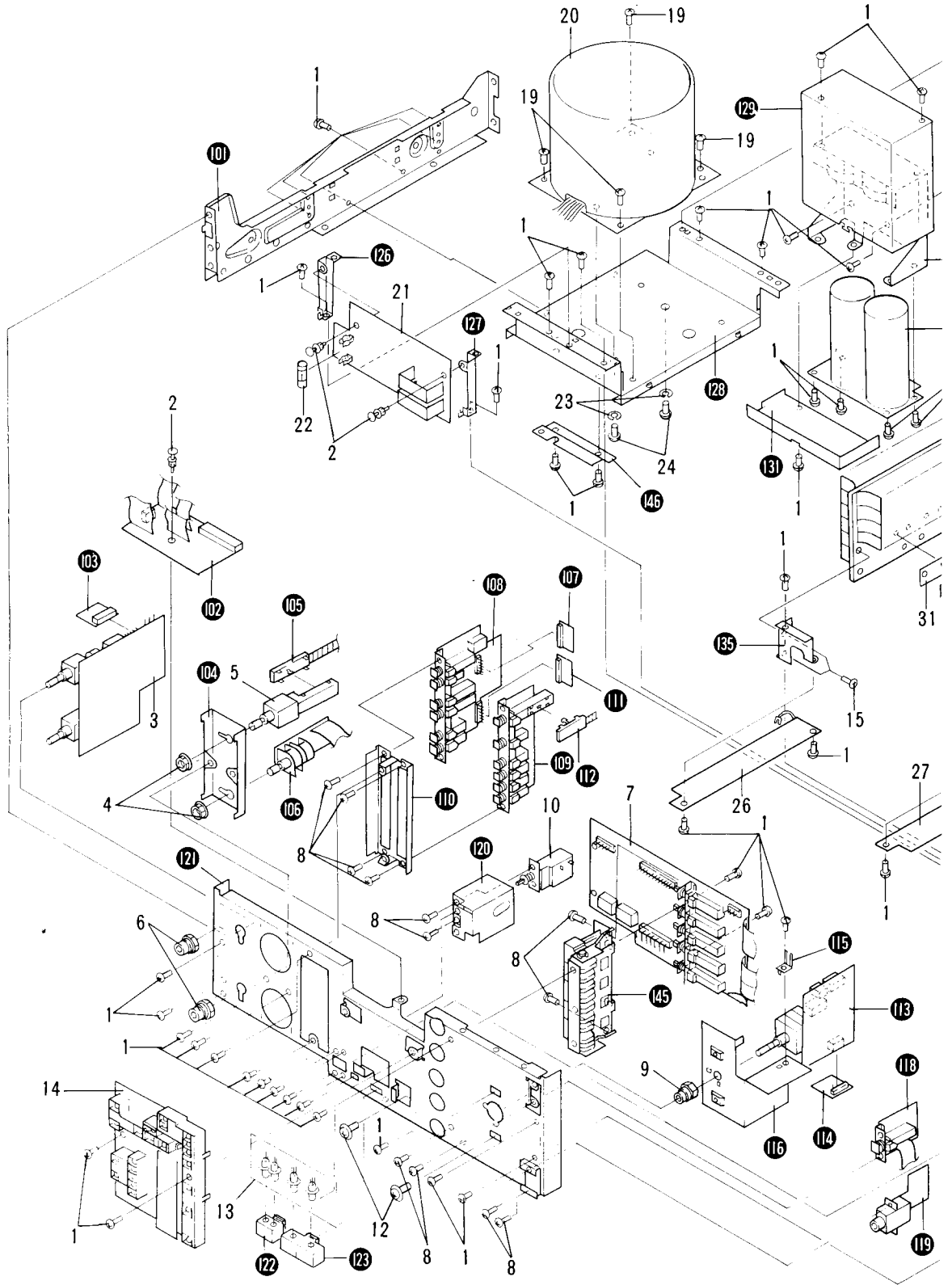

Mark	No.	Part No.	Description	Mark	No.	Part No.	Description
	143.		Connector assembly		148.		Shelf
	144.		Connector assembly		149.		Rear panel
	145.		Lever assembly		150.		Terminal (GND)
	146.		Plate		151.		Grounding plate
	147.		Terminal strip 2-P		152.		Side frame R

23

1

2

3

# 10. ELECTRICAL PA

**NOTES:**

- When ordering resistors, first convert resistors to the following examples.  
 Ex. 1 When there are 2 effective digits (4 and 47k ohm (tolerance is shown by))  
 560Ω    56 × 10<sup>1</sup>    561 . . . .  
 47kΩ    47 × 10<sup>3</sup>    473 . . . .  
 0.5Ω    0R5 . . . . .  
 1Ω    010 . . . . .
- Ex. 2 When there are 3 effective digits (473 ohms)  
 5.62kΩ    562 × 100    5621 . . . .
- The **★** mark found on some components indicates a safety factor of the part. Therefore, when designating.
- For your Parts Stock Control, the fast moving parts are marked with **★★** and **★**.  
**★★** GENERALLY MOVES FASTER THAN **★**  
 This classification shall be adjusted by each number, temperature, humidity, etc.

**Miscellaneous Parts**

**SEMICONDUCTORS**

Mark	Part No.	Symbol & Description
★★	2SC2526/A/-B* (2SC2526/A/-G*)	Q1, Q3, Q5, Q7
★★	2SA1076/A/-B* (2SA1076/A/-G*)	Q2, Q4, Q6, Q8

\*hfe of Q1-Q8 should have the same value.

**FUSES**

Mark	Part No.	Symbol & Description
★★	AEK-015	FU1 (T5A25)
★★	AEK-402	FU2-FU5 (T1A25)
★★	AEK-405	FU6 (T1.6A)

**P.C. BOARD ASSEMBLIES**

Mark	Part No.	Symbol & Description
	GWH-148	Power amplifier as
	GWR-143	Power supply asse
	GWG-154	Tone control asse
	AWF-052	EQ amplifier asse
	GWS-303	REC selector asse
	GWM-188	Function switch as
	GWX-585	Indicator assembly
	AWX-205	Capacitors assembl
	GWX-593	Driver L assembly
	GWX-594	Driver R assembly
	AWR-226	Regulator assembly

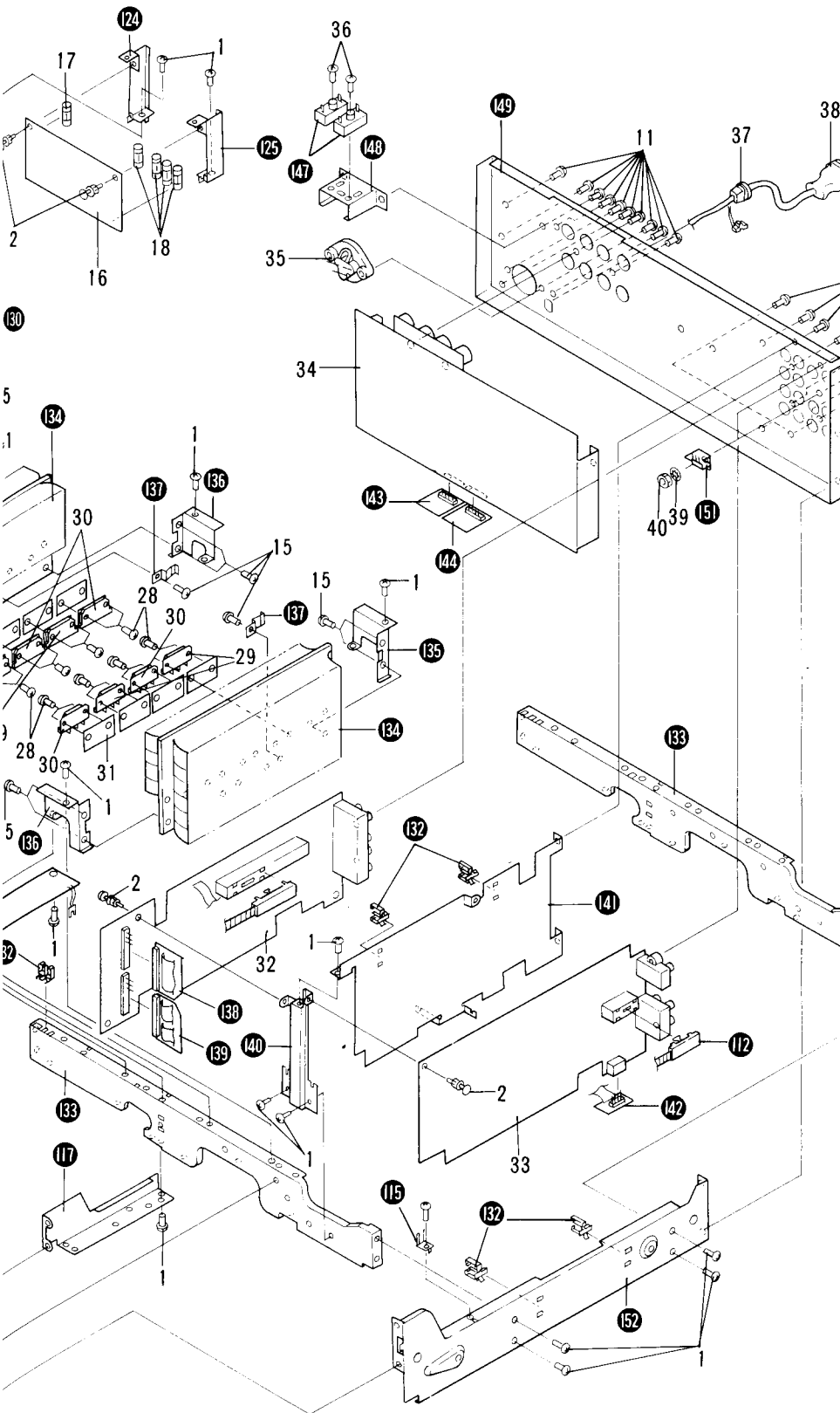

# 9. SCHEMATIC DIAGRAM

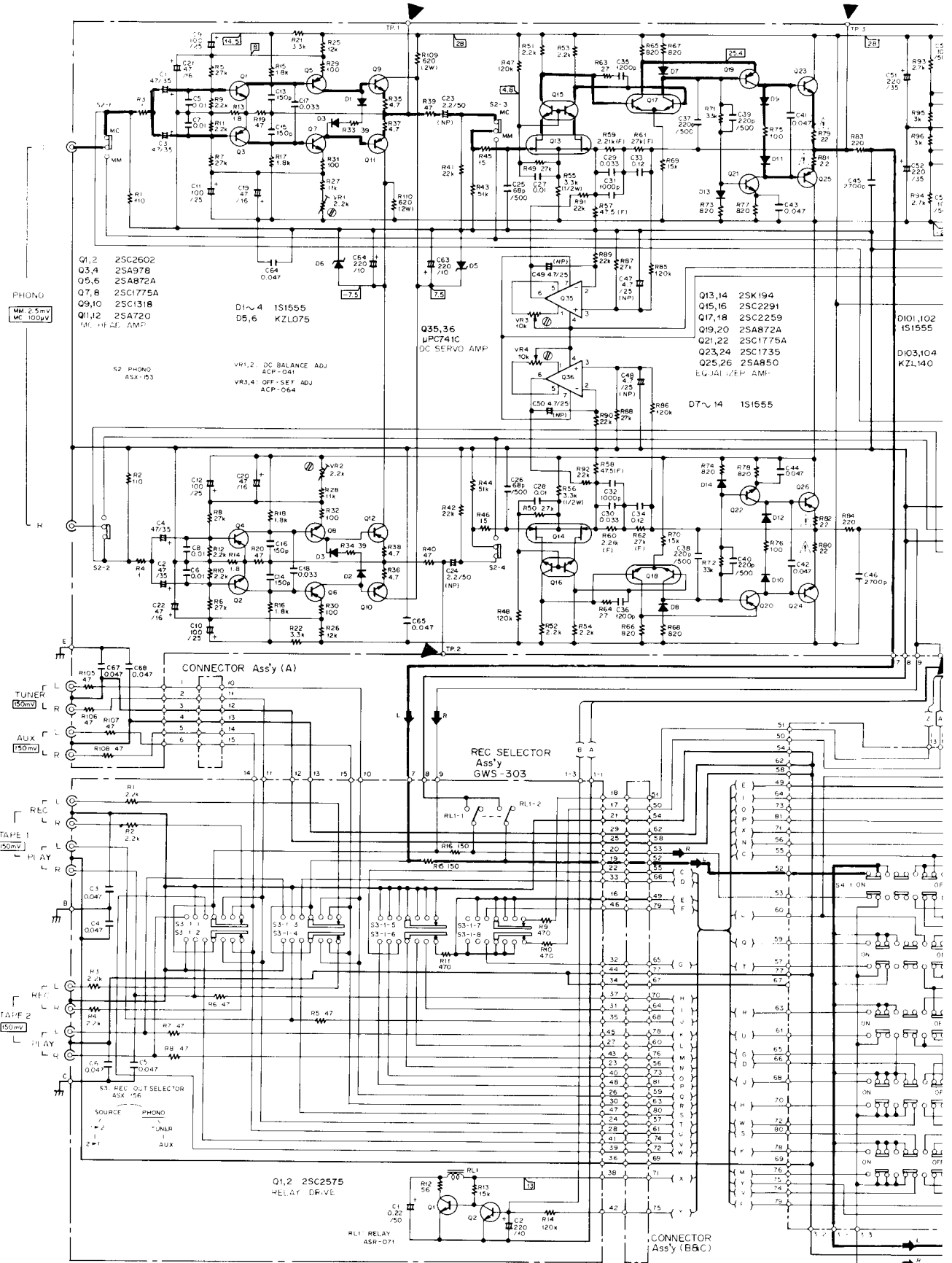

Q1,2 2SC2602  
 Q3,4 2SA978  
 Q5,6 2SA872A  
 Q7,8 2SC1775A  
 Q9,10 2SC1318  
 Q11,2 2SA720

D1~4 1S1555  
 D5,6 KZL075

Q35,36  
 μPC741C  
 DC SERVO AMP

Q13,14 2SK194  
 Q15,16 2SC2291  
 Q17,18 2SC2259  
 Q19,20 2SA872A  
 Q21,22 2SC1775A  
 Q23,24 2SC1735  
 Q25,26 2SA850

D101,102 1S1555  
 D103,104 KZL140

PHONO  
 MM 2.5mV  
 MC 100mV

VR1,2 DC BALANCE ADJ  
 ACP-041  
 VR3,4 OFF-SET ADJ  
 ACP-064

D7~14 1S1555

D101,102 1S1555  
 D103,104 KZL140

TUNER  
 50mV

AUX  
 150mV

TAPE 1  
 150mV

TAPE 2  
 150mV

CONNECTOR Ass'y (A)

REC SELECTOR  
 Ass'y  
 GWS-303

S3 REC OUT SELECTOR  
 ASX-156

Q1,2 2SC2575  
 RELAY DRIVE

RL1 RELAY  
 ASR-071

CONNECTOR  
 Ass'y (B6C)

A

B

C

D

1

2

3



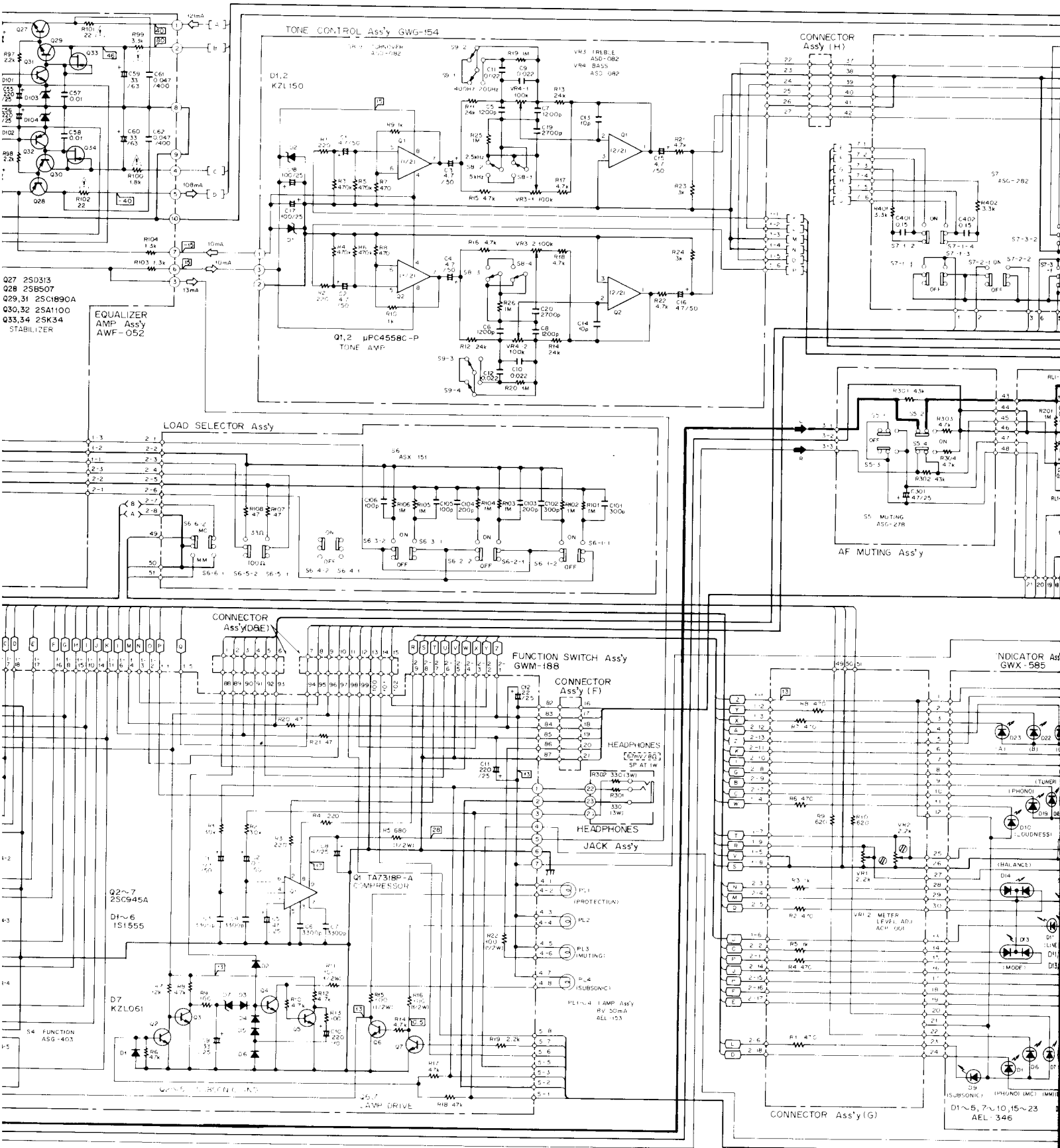

- Q27 2SD313
- Q28 2SB507
- Q29, 31 2SC1890A
- Q30, 32 2SA1100
- Q33, 34 2SK34
- STABILIZER

- Q2~7 2SC945A
- D1~6 1S1555

- D7 KZL061

- S4 FUNCTION ASS-4603

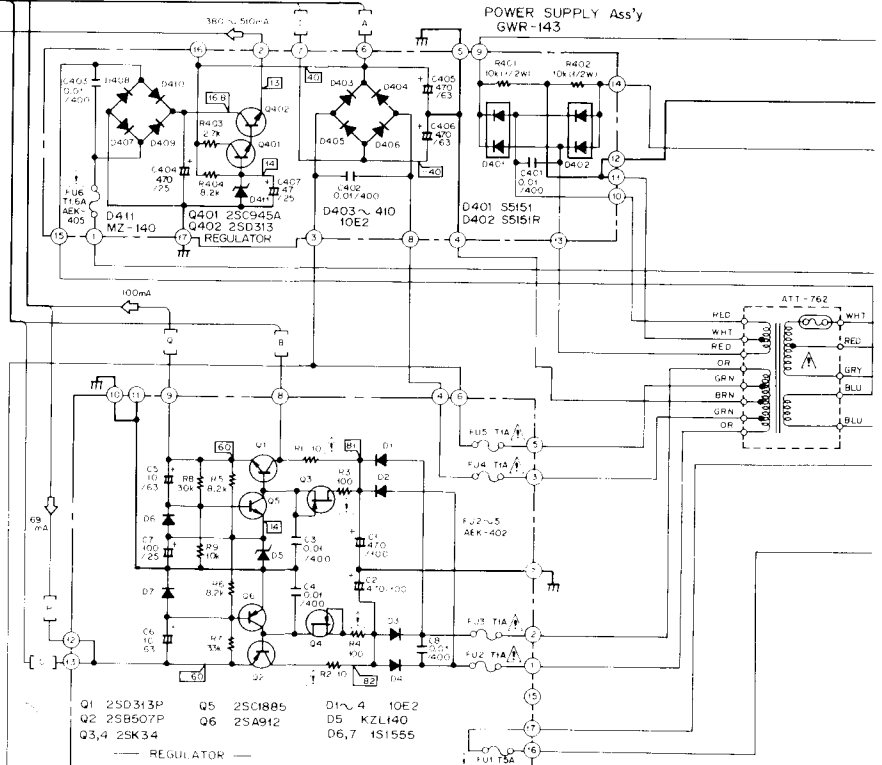
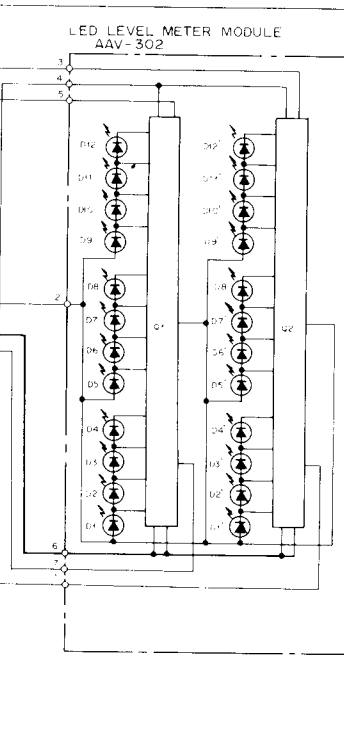
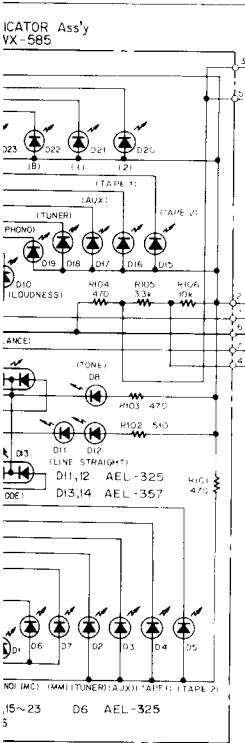
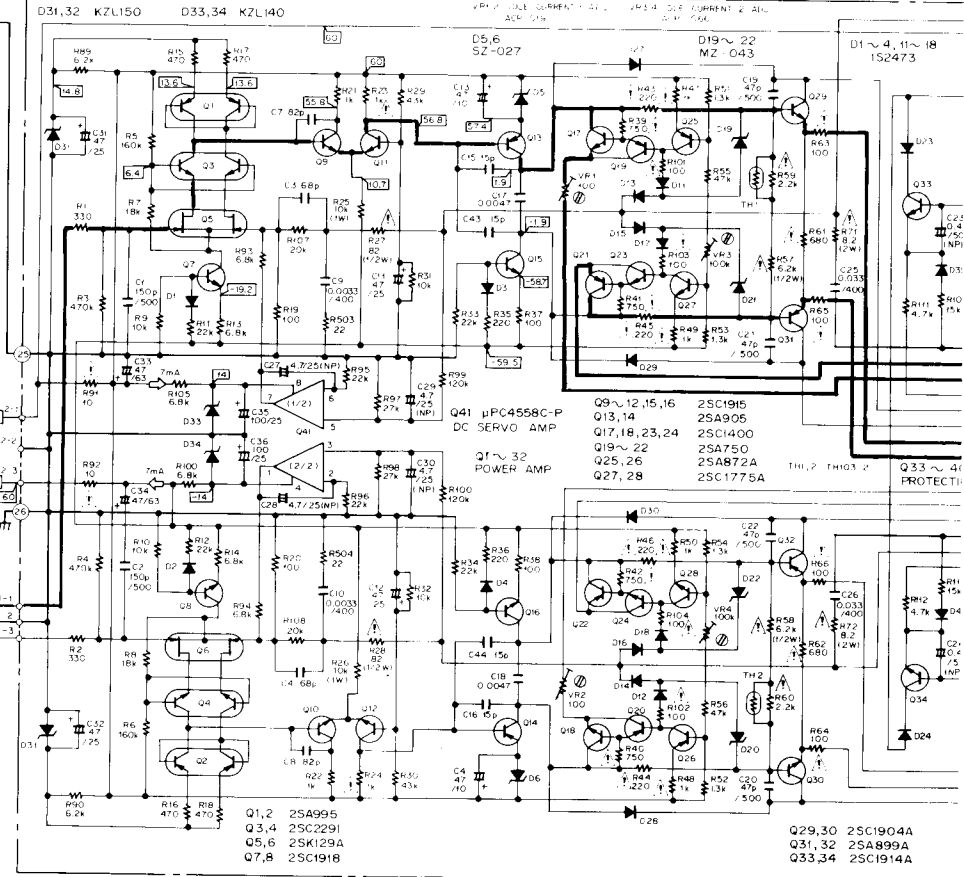
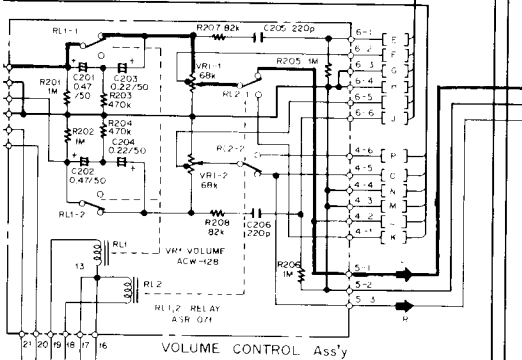
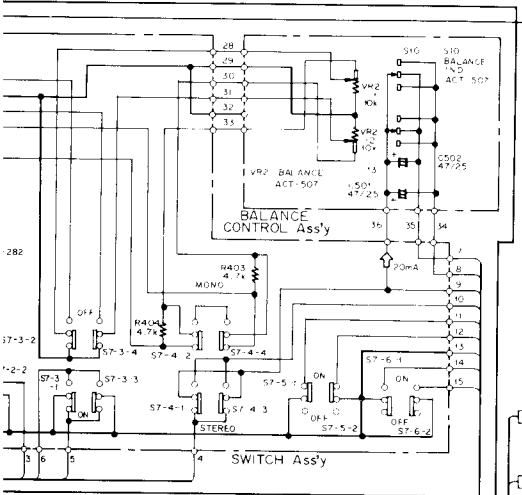

**NOTE:**  
 The indicated semiconductors are representative ones only. Other alternative semiconductors may be used and are listed in the parts list.

A

B

C

D

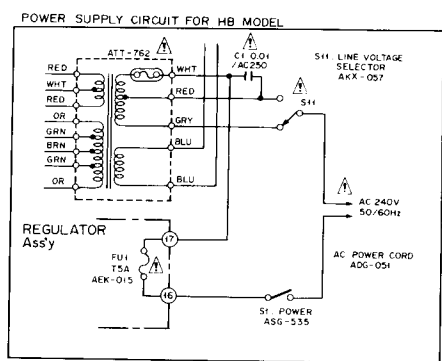
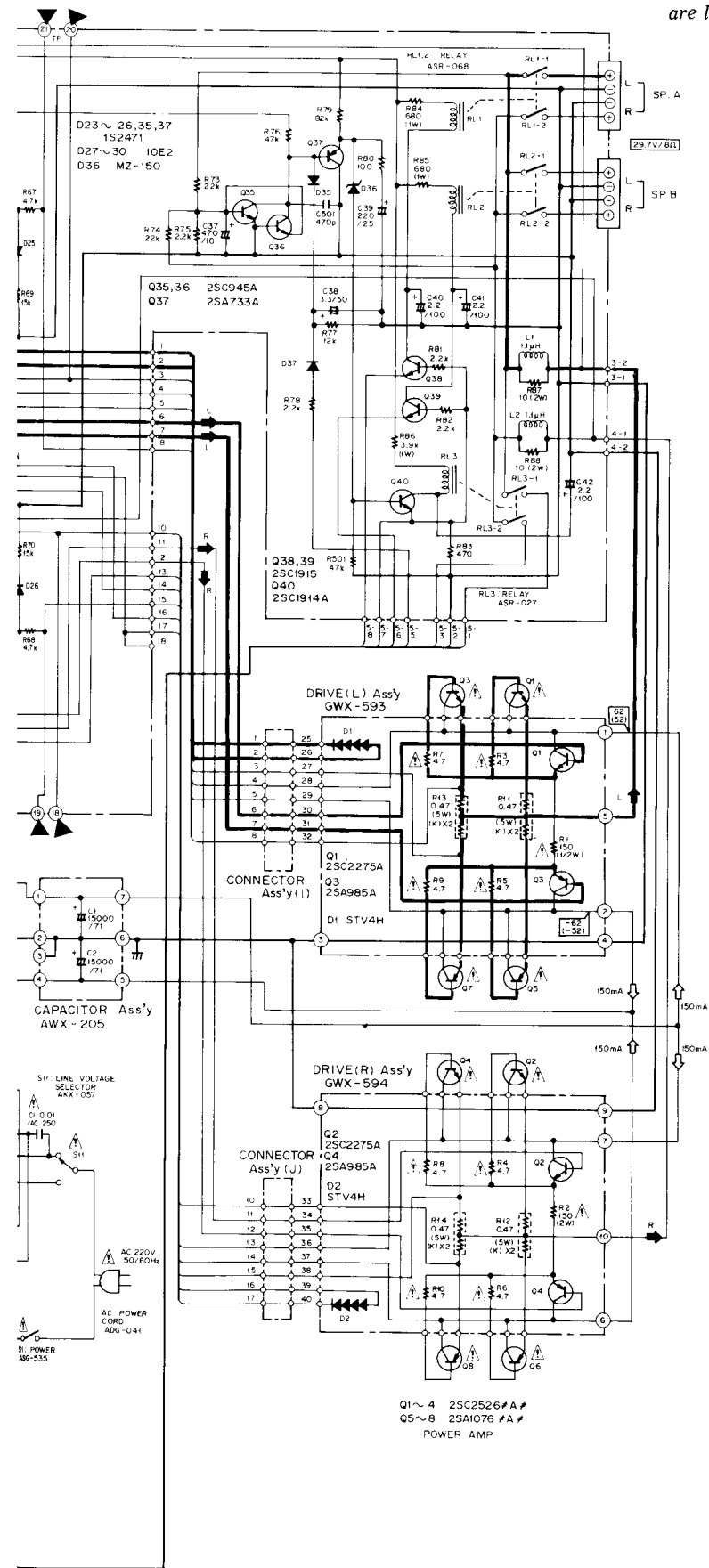

- 1. RESISTORS:  
 Indicated in Ω, kΩ, MΩ, ±5% tolerance unless otherwise noted (K, K, M, M, (F) ±1%, (G) ±2%, (K) ±10%, (M) ±20% tolerance
  - 2. CAPACITORS:  
 Indicated in capacity (pF), voltage (V) unless otherwise noted (pF indication without voltage is 50V, except electrolytic capacitor)
  - 3. VOLTAGE, CURRENT:  
 [Symbol] Signal voltage at 110 W ± 110 W, R<sub>o</sub> output (1k Hz)  
 [Symbol] DC voltage (V) at no input signal  
 Value in [Symbol] is DC voltage at rated power  
 [Symbol] mA DC current at no input signal
  - 4. OTHERS:  
 [Symbol] Signal route  
 [Symbol] Adjusting point  
 The [Symbol] mark found on some component parts indicates the importance of the safety factor of the part. Therefore, when replacing, be sure to use parts of identical designation.
- SWITCHES:**
- S1 POWER ON - OFF
  - S2 PHONO (SIGNAL) MC - MM
  - S3 REC. OUT SELECTOR 2-1-1-2 - SOURCE - PHONO - TUNER - AUX
  - S4-1 FUNCTION (PHONO) ON - OFF
  - S4-2 FUNCTION (TUNER) ON - OFF
  - S4-3 FUNCTION (AUX) ON - OFF
  - S4-4 FUNCTION (TAPE 1) ON - OFF
  - S4-5: FUNCTION (TAPE 2) ON - OFF
  - S5 - MUTING (-20dB) ON - OFF
  - S6-1 MM LOAD (400p) ON - OFF
  - S6-2: MM LOAD (300p) ON - OFF
  - S6-3 MM LOAD (200p) ON - OFF
  - S6-4 MM LOAD (100p) ON - OFF
  - S6-5 MC LOAD 100Ω - 33Ω
  - S6-6 PHONO (IND) MC - MM
  - S7-1 LOUDNESS ON - OFF
  - S7-2 SUBSONIC FILTER (15Hz) ON - OFF
  - S7-3 LINE STRAIGHT ON - OFF
  - S7-4 MODE STEREO - MONO
  - S7-5 SPEAKERS (A) ON - OFF
  - S7-6 SPEAKERS (B) ON - OFF
  - S8 TURNOVER (TREBLE) 2.5kHz - 5kHz
  - S9 TURNOVER (BASS) 400Hz - 200Hz
  - S10 BALANCE (IND) ON - OFF
  - S11 - LINE VOLTAGE SELECTOR 220V - 240V

Q1~4 2SC2526 #A #  
 Q5~8 2SA1076 #A #  
 POWER AMP

This is the basic schematic diagram, but the actual circuit may vary due to improvements in design.

# 10. ELECTRICAL PARTS LIST

**NOTES:**

- When ordering resistors, first convert resistance values into code form as shown in the following examples.

Ex. 1 When there are 2 effective digits (any digit apart from 0), such as 560 ohm and 47k ohm (tolerance is shown by J = 5%, and K = 10%).

560Ω	56 × 10 <sup>1</sup>	561	RD¼PS	561J
47kΩ	47 × 10 <sup>3</sup>	473	RD¼PS	473J
0.5Ω	0R5		RN2H	0R5K
1Ω	010		RS1P	010K



Ex. 2 When there are 3 effective digits (such as in high precision metal film resistors).

5.62kΩ	562 × 100	5621	RN¼SR	5621F
--------	-----------	------	-------	-------

- The  mark found on some component parts indicates the importance of the safety factor of the part. Therefore, when replacing, be sure to use parts of identical designation.
- For your Parts Stock Control, the fast moving items are indicated with the marks **★★** and **★**.  
**★★** GENERALLY MOVES FASTER THAN **★**.  
 This classification shall be adjusted by each distributor because it depends on model number, temperature, humidity, etc.



**Miscellaneous Parts**

**SEMICONDUCTORS**







Mark	Part No.	Symbol & Description
 <b>★★</b>	2SC2526/A/-B* (2SC2526/A/-G*)	Q1, Q3, Q5, Q7
 <b>★★</b>	2SA1076/A/-B* (2SA1076/A/-G*)	Q2, Q4, Q6, Q8

\*hfe of Q1-Q8 should have the same value.

**FUSES**

Mark	Part No.	Symbol & Description
 <b>★★</b>	AEK-015	FU1 (T5A250V)
 <b>★★</b>	AEK-402	FU2-FU5 (T1A250V)
 <b>★★</b>	AEK-405	FU6 (T1.6A250V)

**OTHERS**

Mark	Part No.	Symbol & Description
 <b>★</b>	ATT-762	T1 Power transformer (220V/240V)
 <b>★</b>	ACG-001	C1 Ceramic capacitor (0.01/AC250V)
<b>★★</b>	AEL-153	PL1 Lamp assembly
 <b>★★</b>	ASG-535	S1 Push switch (POWER)
 <b>★★</b>	AKX-057	S10 Line voltage selector
 <b>★</b>	ADG-041	AC power cord (for HE type)
 <b>★</b>	ADG-051	AC power cord (for HB type)

**Power Amplifier Assembly (GWH-148)**

**CAPACITORS**

Mark	Part No.	Symbol & Description
	ACF-015	C1, C2 Mica (150p/500V)
	ACF-017	C19-C22 Mica (47p/500V)
	CCDSL 680J 50	C3, C4
	CCDSL 820J 50	C7, C8
	CCDSL 150J 50	C15, C16, C43, C44
	CQMA 472J 50	C17, C18
	CQMA 332K 400	C9, C10
	CQMA 333K 400	C25, C26
	ACH-318	C27-C30 Electrolytic (4.7/25V, NP)
	CEA 470M 25L	C11, C12, C31, C32
	CEA 470M 63L	C33, C34
	CEA 101M 25L	C35, C36
	CEA 470M 10L	C13, C14
	CEA 471M 10L	C37
	CEA 221M 25L	C39
	CEA 2R2M 100L	C40-C42
	CEA 3R3M 50L	C38
	ACH-356	C23, C24 Electrolytic (0.47/50, NP)
	CKDYB 471K 50	C501

**P.C. BOARD ASSEMBLIES**

Mark	Part No.	Symbol & Description
	GWH-148	Power amplifier assembly
	GWR-143	Power supply assembly
	GWG-154	Tone control assembly
	AWF-052	EQ amplifier assembly
	GWS-303	REC selector assembly
	GWM-188	Function switch assembly
	GWX-585	Indicator assembly
	AWX-205	Capacitors assembly
	GWX-593	Driver L assembly
	GWX-594	Driver R assembly
	AWR-226	Regulator assembly

## RESISTORS

Note: When ordering resistors, convert the resistance value into code form, and then rewrite the part no. as before.

Mark	Part No.	Symbol & Description
★	ACP-019	VR1, VR2 Semifixed (100-B)
★	ACP-066	VR3, VR4 Semifixed (100k-B)
	RD¼PMF □□□ J	R101-R104
	RD¼PMFL □□□ J	R23, R24, R39-R50, R59-R66, R91, R92
	RD½PSF □□□ J	R27, R28, R57, R58
	RS1P □□□ J	R25, R26, R84-R86
	RS2P 100J	R87, R88
	RN2P 8R2K	R71, R72
	RD¼PM □□□ J	R1, R2, R5-R22, R29-R38, R51-R56, R67-R70, R73-R83, R89, R90, R93-R100, R105-R112, R501, R503, R504
	RD¼PM □□□ JNL	R3, R4

## SEMICONDUCTORS

Mark	Part No.	Symbol & Description
★★	2SA995	Q1, Q2
★★	2SC2291	Q3, Q4
★★	2SC1318	Q7, Q8
★★	2SC1915	Q9-Q12, Q15, Q16, Q38, Q39
★★	2SA905	Q13, Q14
★★	2SC1775A-E	Q27, Q28
★★	2SA872A-E	Q25, Q26
★★	2SC1400-E* (2SC1400-U*)	Q17, Q18, Q23, Q24
★★	2SA750-E* (2SA750-U*)	Q19-Q22
	*hfe of Q17-Q24 should have the same value.	
★★	2SK129A	Q5, Q6
★★	2SC1885	Q29, Q30
★★	2SA912	Q31, Q32
★★	2SC1914A	Q33, Q34, Q40
★★	2SC945A (2SC2575)	Q35, Q36
★★	2SA733A (2SA1100)	Q37
★★	μPC4558C-P (NJM4558DX)	Q41
★	1S2473 (1S1555)	D1-D4, D11-D18
★	1S2471	D23-D26, D35, D37, D39, D40
★	SZ-027	D5, D6
★	MZ-043	D19-D22
★	KZL150	D31, D32
★	KZL140	D33, D34
★	MZ-150	D36
★	10E2	D27-D30
★	TH103-2	TH1, TH2

## OTHERS

Mark	Part No.	Symbol & Description
★★	ASR-068	RL1, RL2 Relay
★★	ASR-027	RL3 Relay
	AKE-052	Terminal (SPEAKERS)
	PMZ30P060FMC	Screw 3x6
	VBZ30P060FMC	Screw 3x6

## Power Supply Assembly (GWR-143)

### CAPACITORS

Mark	Part No.	Symbol & Description
	CEA 471M 63L	C405, C406
	CEA 471M 25L	C404
	CEA 470M 25L	C407
	CQMA 103K 400	C401-C403

## RESISTORS

Mark	Part No.	Symbol & Description
	RD¼PM272J	R403
	RD¼PM822J	R404
	RD½PS103J	R401, R402

## SEMICONDUCTORS

Mark	Part No.	Symbol & Description
★★	2SC945A (2SC2575)	Q401
★★	2SD313	Q402
★	S5151	D401
★	MZ-140	D411
★	10E2	D403-D410
★	S5151R	D402

## OTHER

Mark	Part No.	Symbol & Description
	PMZ30P060FMC	Screw 3x6

## Headphone Jack Assembly

Mark	Part No.	Symbol & Description
	RS3P 331J	R301, R302
	AKN-028	Phone jack (PHONES)

## Regulator Assembly (AWR-226)

### CAPACITORS

Mark	Part No.	Symbol & Description
	ACH-343	C1, C2 Electrolytic (470/100V)
	CEA 100M 63L	C5, C6
	CEA 101M 25L	C7
	CQMA 103K 400	C3, C4, C8

## RESISTORS

Note: When ordering resistors, convert the resistance value into code form, and then rewrite the part no. as before.

Mark	Part No.	Symbol & Description
RD¼PMFL 0000 J	R1-R4	
RD¼PM 000 J	R5-R9	

## SEMICONDUCTORS

Mark	Part No.	Symbol & Description
★★	2SD313P	Q1
★★	2SB507P	Q2
★★	2SC1885-R	Q5
★★	2SA912-R	Q6
★★	2SK34-D	Q3, Q4
★	10E2	D1-D4
★	1S1555 (1S2473)	D6, D7
★	KZL140	D5

## OTHER

Mark	Part No.	Symbol & Description
	PBZ30P060FMC	Screw 3x6

## Tone Control Assembly (GWG-154)

### CAPACITORS

Mark	Part No.	Symbol & Description
	CEANL 4R7M 50	C1-C4, C15, C16
	CEA 101M 25L	C17, C18
	CCDSL 100D 50	C13, C14
	CQMA 122J 50	C5-C8
	CQMA 272J 50	C19, C20
	CQMA 223J 50	C9-C12

## RESISTORS

Mark	Part No.	Symbol & Description
★★	ASD-082	VR3, VR4 Variable (BASS, TREBLE) (S8) with switch (TURNOVER)

## SEMICONDUCTORS

Mark	Part No.	Symbol & Description
★★	μPC4558C-P (NJM4558DX)	Q1, Q2
★	KZL150	D1, D2

## Load Selector Assembly

Mark	Part No.	Symbol & Description
	CQSA 301J 50	C101, C102
	CQSA 101J 50	C105, C106
	CQSA 201J 50	C103, C104

Mark	Part No.	Symbol & Description
	RD¼PM 105J	R101-R106
	RD¼PM 470J	R107, R108
★★	ASX-151	S6 Remote push switch (MM/MC, CARTRIDGE LOAD)

## Switch Assembly

Mark	Part No.	Symbol & Description
	CQMA 154J 50	C401, C402
	RD¼PM 472J	R403, R404
★★	ASG-282	S7 Push switch (LOUDNESS, SUBSONIC, LINE STRAIGHT, MODE, SPEAKERS)

## Balance Control Assembly

Mark	Part No.	Symbol & Description
	CEA 470M 25L	C501, C502
★★	ACT-507	VR2 (S10) Variable resistor with switch (BALANCE)

## AF Muting Assembly

Mark	Part No.	Symbol & Description
	CEA 470M 25L	C301
	RD¼PM 433J	R301-R302
	RD¼PM 472J	R303, R304
★★	ASG-278	S5 Push switch (MUTING)

## Volume Control Assembly

### CAPACITORS

Mark	Part No.	Symbol & Description
	CEANL R47M 50	C201, C202
	CCDSL 221J 50	C205, C206
	CEANL R22M 50	C203, C204

### RESISTORS

Mark	Part No.	Symbol & Description
★	ACW-128	VR1 Variable (VOLUME)
	RD¼PM 105J	R201-R208

### OTHERS

Mark	Part No.	Symbol & Description
★★	ASR-071	RL1, RL2 Relay

## Connector Assembly

Note: When ordering resistors, convert the resistance value into code form, and then rewrite the part no. as before.

Mark	Part No.	Symbol & Description
★	ACP-001 RD¼PM □□□ J	VR1, VR2 Semifixed (2.2k-B) R1-R10

## Indicator Assembly

### RESISTORS

Note: When ordering resistors, convert the resistance value into code form, and then rewrite the part no. as before.

Mark	Part No.	Symbol & Description
	RD¼PM □□□ J	R101-R106

### SEMICONDUCTORS

Mark	Part No.	Symbol & Description
★	AEL-346	D1-D5, D7-D10, D15-D23 LED (Green)
★	AEL-325	D6, D11, D12 LED (Orange)
★	AEL-357	D13, D14 LED (Red/Green)
★	AAV-302	LED level meter module

### OTHER

Mark	Part No.	Symbol & Description
	VBZ030P060FMC	Screw 3x6

## EQ Amplifier Assembly (AWF-052)

### CAPACITORS

Mark	Part No.	Symbol & Description
	CEANL 470M 35	C1-C4
	ACH-323	C23, C24 Electrolytic (2.2/50V, NP)
	ACH-318	C47-C50 Electrolytic (4.7/25V, NP)
	CEANL 470M 16	C19-C22
	CEA 100M 50L	C53, C54
	CEA 101M 25L	C9-C12
	CEA 330M 63L	C60
	CEA 221M 25L	C55, C56
	CEA 221M 35L	C51, C52
	CEA 221M 10L	C63, C64
	CEA 330M 80L	C59
	CQMA 333J 50	C17, C18
	CQMA 103J 50	C5-C8, C27, C28
	CQMA 122J 50	C35, C36
	CQMA 473J 50	C41-C44, C65-C68
	ACF-016	C25, C26 Mica (68p/500V)
	CKDYB 103K 50	C57, C58
	CCDSL 151J 50	C13-C16
	CCDSL 221J 500	C37-C40
	CQMA 473K 400	C61, C62
	CQPA 124G 50	C33, C34
	CQPA 333G 50	C29, C30
	CQPA 102G 50	C31, C32
	CQSA 272J 50	C45, C46

## RESISTORS

Note: When ordering resistors, convert the resistance value into code form, and then rewrite the part no. as before.

Mark	Part No.	Symbol & Description
★	ACP-041	VR1, VR2 Semifixed (2.2k-B)
★	ACP-064	VR3, VR4 Semifixed (10k-B)
	RN¼PQ □□□□ F	R57-R62
	RS2P 621J	R109, R110
	RD¼PS 332J	R55, R56
	RD¼PMFL 220J	R79-R82, R101, R102
	RD¼PM 273JNL	R5-R8
	RD¼PM □□□ J	R1-R4, R9-R54, R63-R78, R83-R100, R103-R108

### SEMICONDUCTORS

Mark	Part No.	Symbol & Description
★★	2SC2602-G	Q1, Q2
★★	2SA978-G	Q3, Q4
★★	2SC1775A-E	Q7, Q8
★★	2SA872A-E	Q5, Q6
★★	2SC1318	Q9, Q10
★★	2SA720	Q11, Q12
★★	2SK194	Q13, Q14
★★	2SC2291	Q15, Q16
★★	2SC2259	Q17, Q18
★★	2SC1775A	Q21, Q22
★★	2SA872A	Q19, Q20
★★	2SC1735	Q23, Q24
★★	2SA850	Q25, Q26
★★	μPC741C (NJM4558DX)	Q35, Q36
★★	2SD313	Q27
★★	2SB507	Q28
★★	2SC1890A	Q29, Q31
★★	2SA1100 (2SA733A)	Q30, Q32
★★	2SK34-D	Q33, Q34
★	1S1555 (1S2473)	D1-D4, D7-D14, D101, D102
★	KZL075	D5, D6
★	KZL140	D103, D104

### OTHERS

Mark	Part No.	Symbol & Description
	AKB-080	Terminal (PHONO)
	AKB-078	Terminal (TUNER, AUX)
★★	ASX-153	Remote slide switch (MM/MC)
	PBZ30P060FMC	Screw 3x6

## REC Selector Assembly (GWS-303)

## CAPACITORS

Mark	Part No.	Symbol & Description
	CEA R22M 50L	C1
	CEA 221M 25L	C2
	CQMA 473J 50	C3-C6

## RESISTORS

Note: When ordering resistors, convert the resistance value into code form, and then rewrite the part no. as before.

Mark	Part No.	Symbol & Description
	RD $\frac{1}{2}$ PM $\square\square\square$ J	R1-R16

## SEMICONDUCTORS

Mark	Part No.	Symbol & Description
★★	2SC2575	Q1, Q2

## OTHERS

Mark	Part No.	Symbol & Description
★★	ASX-156	Remote slide switch (REC SELECTOR)
★★	AKB-078	Terminal (TAPE)
★★	ASR-071	RL1 Relay

## Function Switch Assembly (GWM-188)

## CAPACITORS

Mark	Part No.	Symbol & Description
	CEA 0R1M 50L	C1, C2
	CEA 470M 25L	C5, C8
	CQMA 332J 50	C3, C4, C6, C7
	CEA 330M 25L	C9
	CEA 221M 10L	C10
	CEA 221M 25L	C11
	CEA 220M 25L	C12

## RESISTORS

Note: When ordering resistors, convert the resistance value into code form, and then rewrite the part no. as before.

Mark	Part No.	Symbol & Description
	RD $\frac{1}{2}$ PS $\square\square\square$ J	R5, R11, R15, R16, R22
	RD $\frac{1}{2}$ PM $\square\square\square$ J	R1-R4, R6-R10, R12-R14, R17-R21

## SEMICONDUCTORS

Mark	Part No.	Symbol & Description
★★	TA7318P-A	Q1
★★	2SC945A (2SC2575)	Q2-Q7
★	1S1555 (1S2473)	D1-D6
★	KZL061	D7

## SWITCH

Mark	Part No.	Symbol & Description
★★	ASG-403	S4 Push switch (FUNCTION)

## Driver R Assembly (GWX-594)

## RESISTORS

Note: When ordering resistors, convert the resistance value into code form, and then rewrite the part no. as before.

Mark	Part No.	Symbol & Description
⚠	RD $\frac{1}{2}$ PSF 151J	R2
⚠	RD $\frac{1}{2}$ PMF 4R7J	R4, R6, R8, R10
	ACN-114	R12, R14 Wire wound (0.47/5Wx2)

## SEMICONDUCTORS

Mark	Part No.	Symbol & Description
★★	2SC2275A-Q* (2SC2275A-R*)	Q2
★★	2SA985A-Q* (2SA985A-R*)	Q4
*hfe of Q2 and Q4 should have the same value.		
★	STV4H	D2

## OTHER

Mark	Part No.	Symbol & Description
	PBZ30P060FMC	Screw 3x6

## Capacitors Assembly (AWX-205)

Mark	Part No.	Symbol & Description
	ACH-210	C1, C2 Electrolytic capacitor (15000/71V)
	ABA-261	Brazier head screw

## Driver L Assembly (GWX-593)

## RESISTORS

Note: When ordering resistors, convert the resistance value into code form, and then rewrite the part no. as before.

Mark	Part No.	Symbol & Description
⚠	RD $\frac{1}{2}$ PMF 4R7J	R3, R5, R7, R9
⚠	RD $\frac{1}{2}$ PSF 151J	R1
	ACN-114	R11, R13 Wire wound (0.47/5Wx2)

## SEMICONDUCTORS

Mark	Part No.	Symbol & Description
★★	2SC2275A-Q* (2SC2275A-R*)	Q1
★★	2SA985A-Q* (2SA985A-R*)	Q3
*hfe of Q1 and Q3 should have same value.		
★	STV4H	D1

## OTHER

Mark	Part No.	Symbol & Description
	PBZ30P060FMC	Screw 3x6



# 11. ADJUSTMENTS

## Power Amplifier

- Turn VR1, VR3 (L) and VR2, VR4 (R) fully around in the counter-clockwise direction.
- Without any load or input signal, turn the POWER switch ON.

Adjustment point	Prescribed value	Measuring terminals
VR1(L)	50mVDC	no. 21(+) and no. 20(-)
VR3(L)	75mVDC	
VR2(R)	50mVDC	no. 19(+) and no. 18(-)
VR4(R)	75mVDC	

## Output Power Indicator Calibration

1. Set the LINE STRAIGHT OFF switch to OFF (LINE STRAIGHT) position.
2. Set the SPEAKERS selector to the A position, and connect an 8Ω resistor and AC voltmeter to the speaker output terminals.
3. Set the FUNCTION switch to the AUX position, and apply a 1kHz, 150mV signal to the AUX input terminals.

4. Adjust the VOLUME control for an AC voltmeter reading of 28V.
5. Adjust VR1 (L) and VR2 (R) on the connector assembly so that the all points of the output power indicators light at above 28V.

## Preamplifier (EQ Amplifier Assembly)

- Without input signal, turn the POWER switch ON.

Adjustment point	Prescribed value	Measuring terminals
<b>MC Amplifier DC Balance</b>		
VR1(L)	0 ±30mV DC	TP1 and ground
VR2(R)	0 ±30mV DC	TP2 and ground
<b>EQ Amplifier DC Balance</b>		
VR3(L)	0 ±1mV DC	TP3 and ground
VR4(R)	0 ±1mV DC	TP4 and ground

