

AP-D30/C  
AP-Q50/C

# AKAI SERVICE MANUAL



DIRECT DRIVE AUTO-RETURN TURNTABLE

MODEL **AP-D30/C**

QUARTZ DIRECT DRIVE AUTO-RETURN TURNTABLE

MODEL **AP-Q50/C**



AP-D30/C



AP-Q50/C

**DIRECT DRIVE AUTO-RETURN TURNTABLE**

MODEL **AP-D30/C**

**QUARTZ DIRECT DRIVE AUTO-RETURN TURNTABLE**

MODEL **AP-Q50/C**

ALSO APPLICABLE TO BLACK PANEL MODEL

SECTION 1	SERVICE MANUAL .....	3
SECTION 2	PARTS LIST .....	35
SECTION 3	SCHEMATIC DIAGRAM.....	52

---

1000

---

SECTION 1

**SERVICE MANUAL**

TABLE OF CONTENTS

<b>I. TECHNICAL DATA</b> .....	<b>4</b>
1. MODEL AP-D30/C .....	4
2. MODEL AP-Q50/C .....	5
<b>II. DISMANTLING OF UNIT</b> .....	<b>6</b>
<b>III. CONTROLS</b> .....	<b>7</b>
1. MODEL AP-D30/C .....	7
2. MODEL AP-Q50/C .....	8
<b>IV. PRINCIPAL PARTS LOCATION</b> .....	<b>9</b>
1. MODEL AP-D30/C .....	9
2. MODEL AP-Q50/C .....	10
<b>V. VOLTAGE AND CYCLE CONVERSION</b> .....	<b>11</b>
1. VOLTAGE CONVERSION .....	11
2. CYCLE CONVERSION .....	11
<b>VI. BLOCK DIAGRAM</b> .....	<b>12</b>
1. MODEL AP-D30/C .....	12
2. MODEL AP-Q50/C .....	12
<b>VII. EXPLANATION OF HOW THE DC BRUSHLESS DD MOTOR WORKS</b> .....	<b>13</b>
<b>VIII. EXPLANATION OF HOW THE SERVO CIRCUITRY WORKS</b> .....	<b>15</b>
1. MODEL AP-D30/C .....	15
2. MODEL AP-Q50/C .....	16
<b>IX. MECHANICAL ADJUSTMENT</b> .....	<b>18</b>
1. STYLUS PRESSURE ADJUSTMENT .....	18
2. OVERHANG ADJUSTMENT .....	19
3. AUTO-RETURN ADJUSTMENT .....	19
4. ARM LIFTER ADJUSTMENT .....	20
5. MUTE SWITCH INSTALLATION POSITION ADJUSTMENT .....	21
6. RETURN PLUNGER INSTALLATION POSITION ADJUSTMENT .....	21
<b>X. ELECTRICAL ADJUSTMENT</b> .....	<b>22</b>
1. MODEL AP-D30/C .....	22
2. MODEL AP-Q50/C .....	24
<b>XI. CLASSIFICATION OF VARIOUS P.C BOARDS</b> .....	<b>26</b>
1. P.C BOARD TITLE AND IDENTIFICATION NUMBER .....	26
2. MODEL AP-D30/C COMPOSITION OF VARIOUS P.C BOARDS .....	27
3. MODEL AP-Q50/C COMPOSITION OF VARIOUS P.C BOARDS .....	28

For basic adjustments, measuring methods, and operating principles, refer to GENERAL TECHNICAL MANUAL.

# I . TECHNICAL DATA

## 1. MODEL AP-D30/C

TURNTABLE	Aluminum alloy die cast
DRIVE SYSTEM & MECHANISM	Direct Drive, Auto-return
MOTOR	DC Servo Motor
SPEED & PITCH CONTROL	33-1/3, 45 rpm $\pm 5\%$
WOW & FLUTTER	0.05% (DIN), 0.035% (JIS)
RUMBLE	45 dB (DIN A) 70 dB (DIN B) 45 dB (JIS)
TONE ARM	Static balanced
EFFECTIVE ARM LENGTH	220 mm
STYLUS PRESSURE ADJUSTMENT RANGE	0 to 3 grams
APPLICABLE CARTRIDGE WEIGHT	4 to 12 grams
ARM LIFTER	Oil Damped
OVERHANG	15 mm
OFFSET ANGLE	22°30'
HORIZONTAL TRACKING ERROR ANGLE	+3°5', -1°13'
SHELL WEIGHT	8.2 grams
CARTRIDGE	VM (Dual Moving Magnet) type (Model AP-D30 does not include cartridge)
OUTPUT VOLTAGE	5 mV (DIN 45541)
CHANNEL SEPARATION	More than 20 dB (DIN 45541)
OPTIMAL STYLUS PRESSURE	2 grams
STATIC VERTICAL COMPLIANCE	$17.7 \times 10^{-6}$ cm/dyn
STATIC HORIZONTAL COMPLIANCE	$29.1 \times 10^{-6}$ cm/dyn
POWER REQUIREMENTS	120V, 60 Hz for Canada and USA 220 - 240V, 50 Hz for Europe and Australia 110 - 120/220 - 240V, 50/60 Hz for the other countries
POWER CONSUMPTION	7 Watts
DIMENSIONS	440 (W) x 140 (H) x 403 (D) mm (17.3 x 5.5 x 15.8) inches
WEIGHT	5.5 kg (12.1 lbs)

\* For improvement purposes, specifications and design are subject to change without notice.

## 2. MODEL AP-Q50/C

TURNTABLE	Aluminum alloy die cast
DRIVE SYSTEM & MECHANISM	Quartz locked direct drive, Auto-return
MOTOR	DC Servo Motor
SPEED & PITCH CONTROL	33-1/3, 45 rpm $\pm$ 5%
WOW & FLUTTER	0.050% (DIN), 0.035% (JIS), With Quartz lock off
RUMBLE	45 dB (DIN A) 70 dB (DIN B) 45 dB (JIS)
TONE ARM	Static balanced
EFFECTIVE ARM LENGTH	220 mm
STYLUS PRESSURE ADJUSTMENT RANGE	0 to 3 grams
APPLICABLE CARTRIDGE WEIGHT	4 to 12 grams
ARM LIFTER	Oil Damped
OVERHANG	15 mm
OFFSET ANGLE	22° 30'
HORIZONTAL TRACKING ERROR ANGLE	+3° 5', -1° 13'
SHELL WEIGHT	8.2 grams
CARTRIDGE	VM (Dual Moving Magnet) type (Model AP-Q50 does not include cartridge)
OUTPUT VOLTAGE	5 mV (DIN 45541)
CHANNEL SEPARATION	More than 20 dB (DIN 45541)
OPTIMAL STYLUS PRESSURE	2 grams
STATIC VERTICAL COMPLIANCE	$17.7 \times 10^{-6}$ cm/dyn
STATIC HORIZONTAL COMPLIANCE	$29.1 \times 10^{-6}$ cm/dyn
POWER REQUIREMENTS	120V, 60 Hz for Canada and USA 220 – 240V, 50 Hz for Europe, UK and Australia 110 – 120/220 – 240V, 50/60 Hz for the other countries
POWER CONSUMPTION	7 Watts
DIMENSIONS	440 (W) x 140 (H) x 403 (D) mm (17.3 x 5.5 x 15.8) inches
WEIGHT	5.7 kg (12.6 lbs)

\* For improvement purposes, specifications and design are subject to change without notice.

## II. DISMANTLING OF UNIT

In case of trouble, etc. necessitating dismantling, please dismantle in the order shown in the photographs. Reassemble in reverse order.

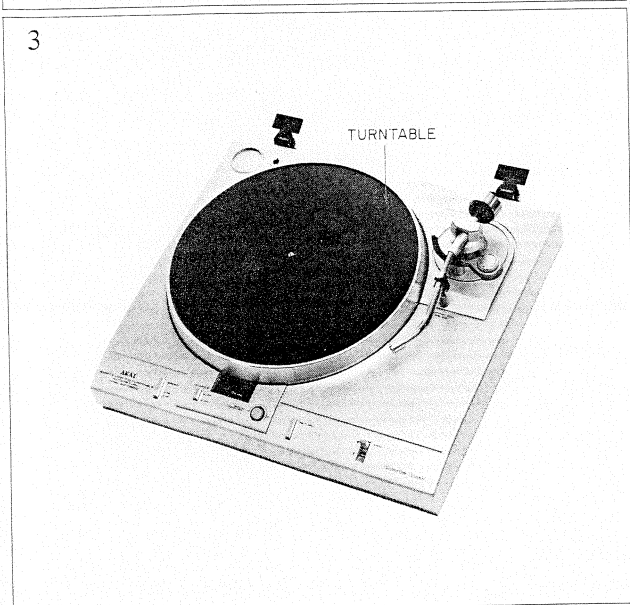
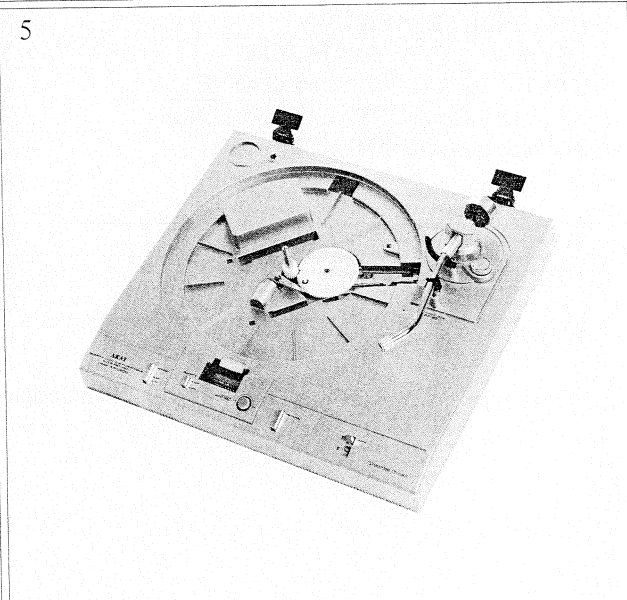
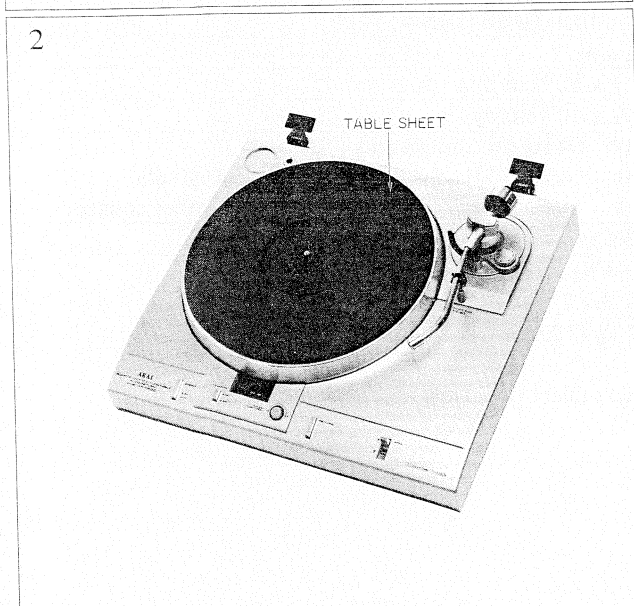
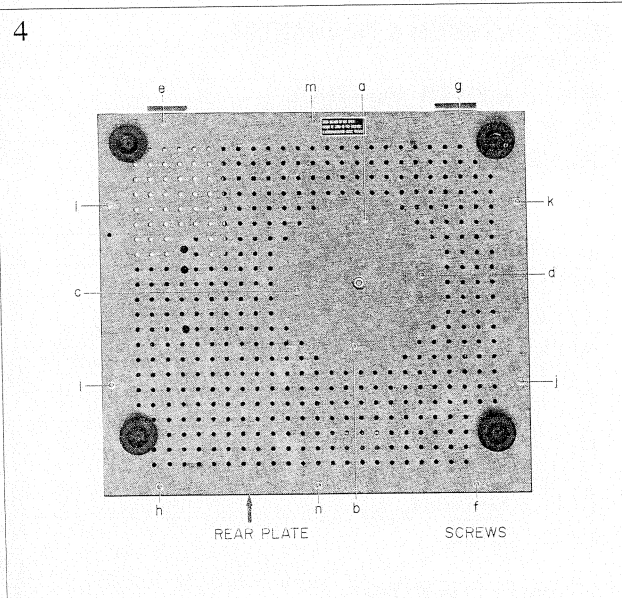
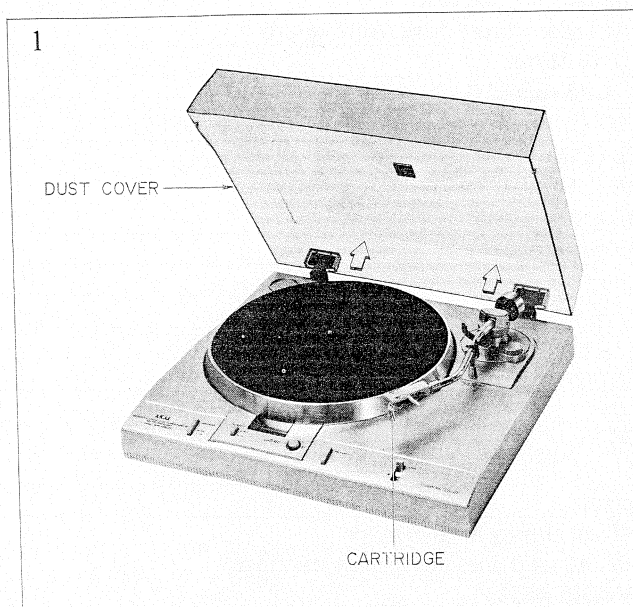

### III. CONTROLS

#### 1. MODEL AP-D30/C

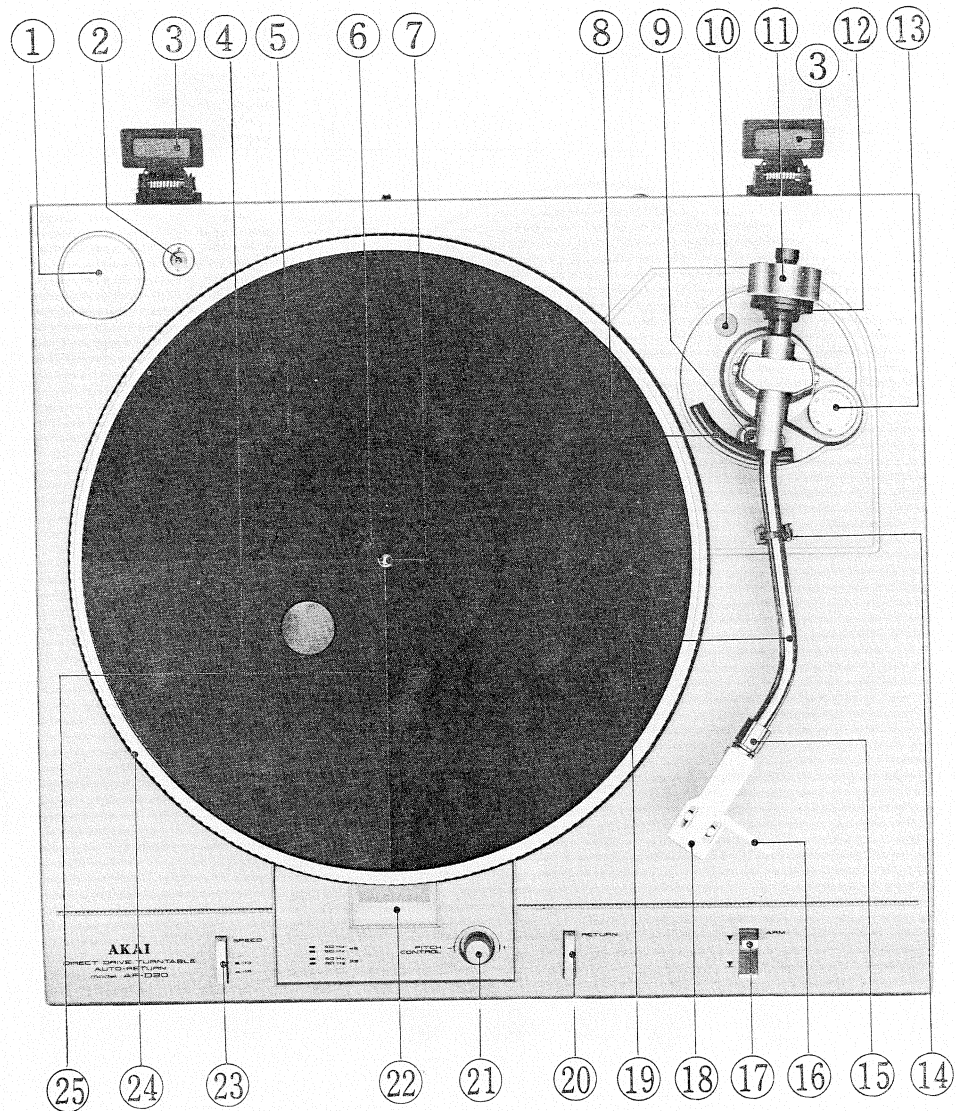

- |  |   |
|--|---|
| 1. 45 RPM ADAPTER HOLDER                         | 14. TONE ARM REST                                     |
| 2. CARTRIDGE SHELL HOLDER                        | 15. LOCKING NUT                                       |
| 3. HINGES  | 16. CARTRIDGE SHELL FINGER LEVER                      |
| 4. TURNTABLE PLATTER                             | 17. TONE ARM LIFTER SWITCH<br>( ▼ to Lift ▼ to Lower) |
| 5. RUBBER MAT                                    | 18. CARTRIDGE SHELL                                   |
| 6. GROOVE FOR OVERHANG ADJUSTMENT                | 19. TONE ARM  |
| 7. SPINDLE                                       | 20. RETURN SWITCH                                     |
| 8. TONE ARM LIFTER                               | 21. PITCH CONTROL                                     |
| 9. TONE ARM LIFTER ELEVATION ADJUSTMENT<br>SCREW | 22. BUILT-IN STROBE LIGHT                             |
| 10. AUTO-RETURN ADJUSTMENT SCREW CAP             | 23. 33/45 RPM SPEED SELECTOR<br>( ■ 33 ■ 45)          |
| 11. MAIN WEIGHT                                  | 24. STROBE MARKINGS                                   |
| 12. STYLUS PRESSURE SCALE RING                   | 25. GROOVE FOR AUTO-RETURN ADJUSTMENT                 |
| 13. ANTI-SKATING ADJUSTER                        |   |

A cartridge is not included with AP-D30.



## 2. MODEL AP-Q50/C

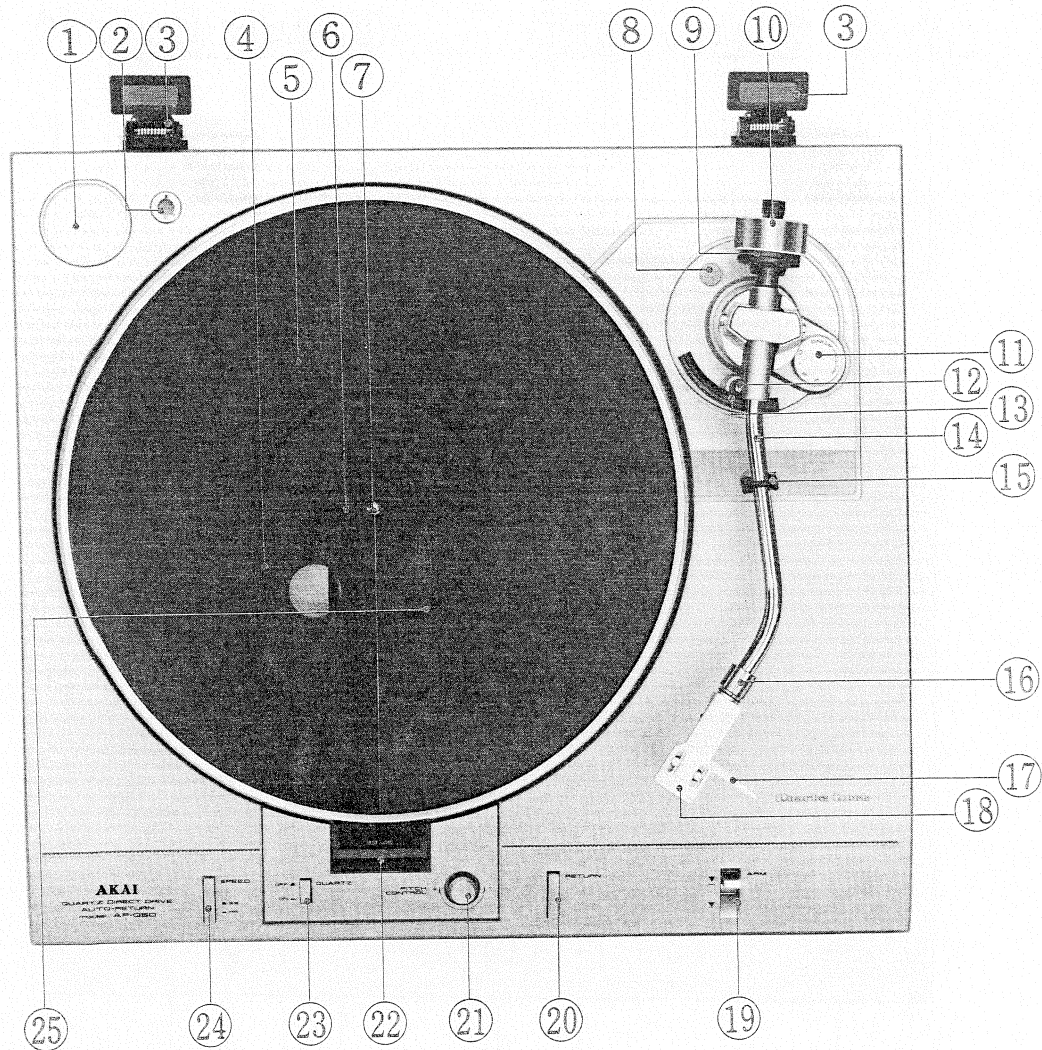

Fig. 2

- |  |   |
|--|---|
| 1. 45 RPM ADAPTER HOLDER                       | 14. TONE ARM  |
| 2. CARTRIDGE SHELL HOLDER                      | 15. TONE ARM REST                                     |
| 3. HINGES                                      | 16. LOCKING NUT                                       |
| 4. TURNTABLE PLATTER                           | 17. CARTRIDGE SHELL FINGER LEVER                      |
| 5. RUBBER MAT                                  | 18. CARTRIDGE SHELL                                   |
| 6. GROOVE FOR OVERHANG ADJUSTMENT              | 19. TONE ARM LIFTER SWITCH<br>( ▼ to Lift ▼ to Lower) |
| 7. SPINDLE                                     | 20. RETURN SWITCH                                     |
| 8. AUTO-RETURN ADJUSTMENT SCREW CAP            | 21. PITCH CONTROL                                     |
| 9. STYLUS PRESSURE SCALE RING                  | 22. STROBE/SPEED VIEW WINDOW                          |
| 10. MAIN WEIGHT                                | 23. LOCK-IN QUARTZ SWITCH                             |
| 11. ANTI-SKATING ADJUSTER                      | 24. 33/45 RPM SPEED SELECTOR<br>( ■ 33 ■ 45)          |
| 12. TONE ARM LIFTER ELEVATION ADJUSTMENT SCREW | 25. AUTO-RETURN ADJUSTMENT GROOVE                     |
| 13. TONE ARM LIFTER                            |   |

A cartridge is not included with AP-Q50.

# IV. PRINCIPAL PARTS LOCATION

## 1. MODEL AP-D30/C

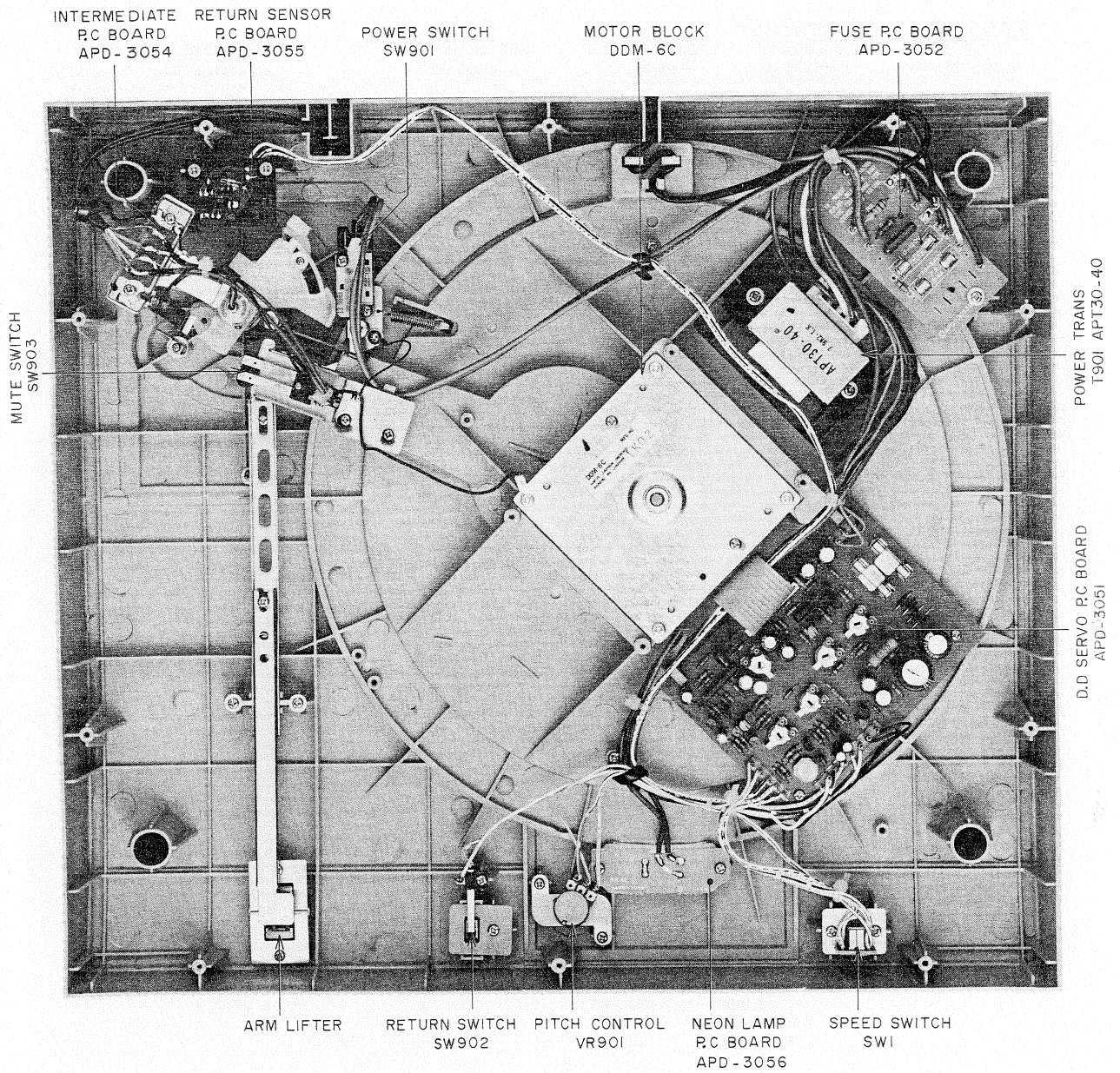
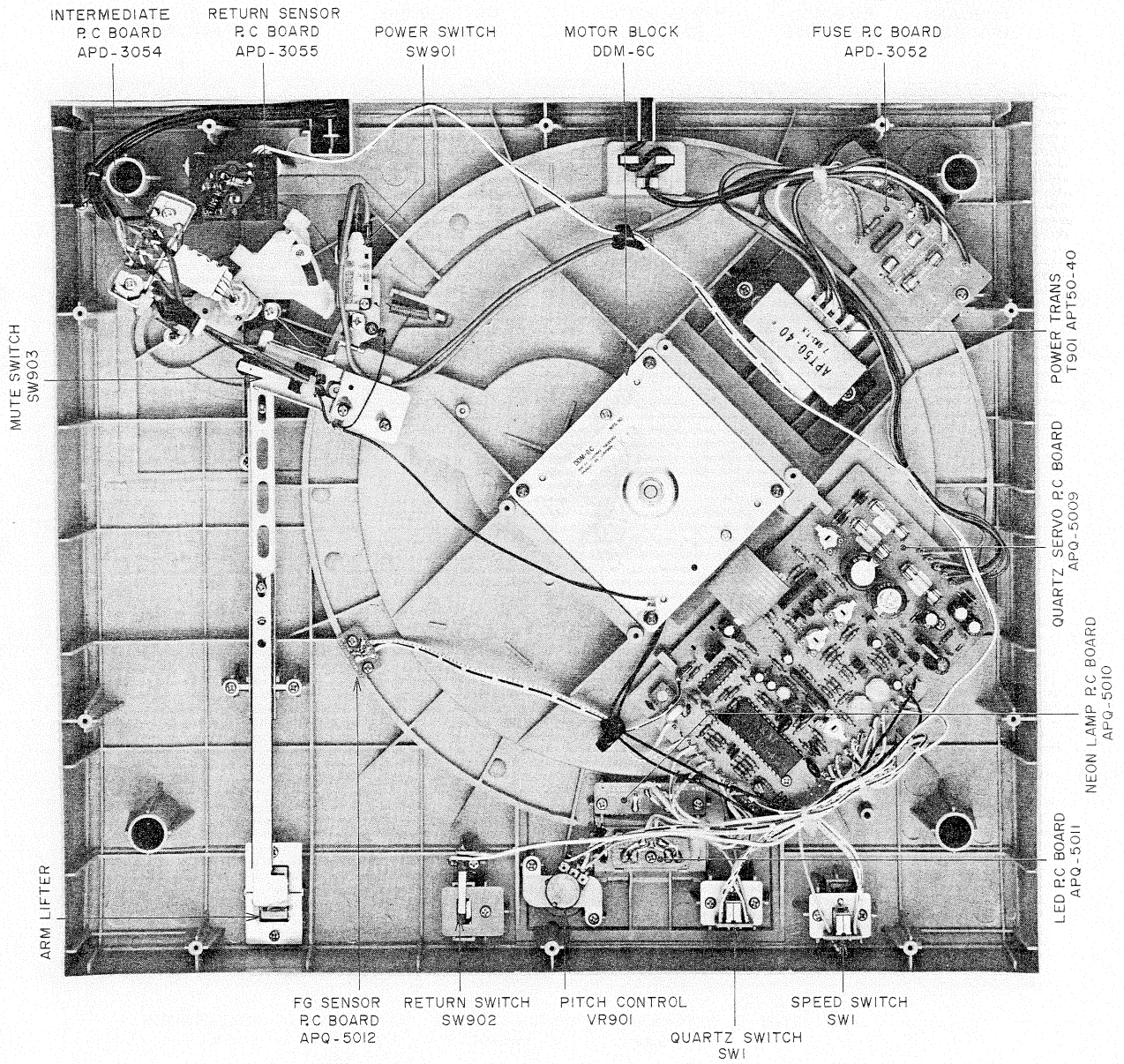

Fig. 3 Bottom View

## 2. MODEL AP-Q50/C



## V. VOLTAGE AND CYCLE CONVERSION

---

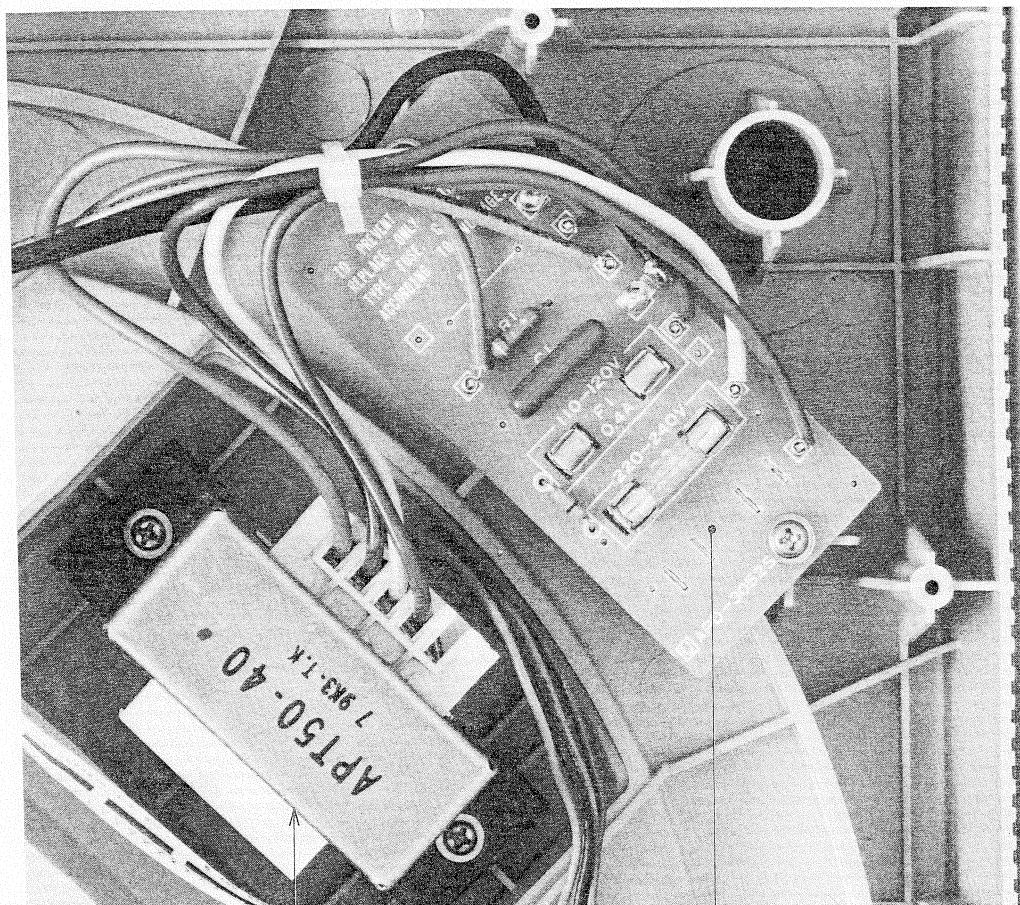

POWER TRANS

FUSE P.C BOARD

110V-120V : F1 0.4A  
220V-240V : F2 0.4A

Fig. 5 Voltage Conversion (U/T only)

### 1. VOLTAGE CONVERSION

Models for Canada, USA, Australia and Europe are not equipped with this facility. This machine can be set to 110 – 120V/220 – 240V as required.

Each machine is preset at the factory according to destination but if voltage change is necessary it can be accomplished as follows only by qualified personnel.

1. Disconnect power supply cord.
2. Remove the bottom cover.
3. Remove existing Line Voltage Fuse and insert required Line Voltage Fuse in the proper fuse holder according to the printed instructions.

### 2. CYCLE CONVERSION

With DC servo motor, cycle conversion is not necessary.

# VI. BLOCK DIAGRAM

## 1. MODEL AP-D30/C

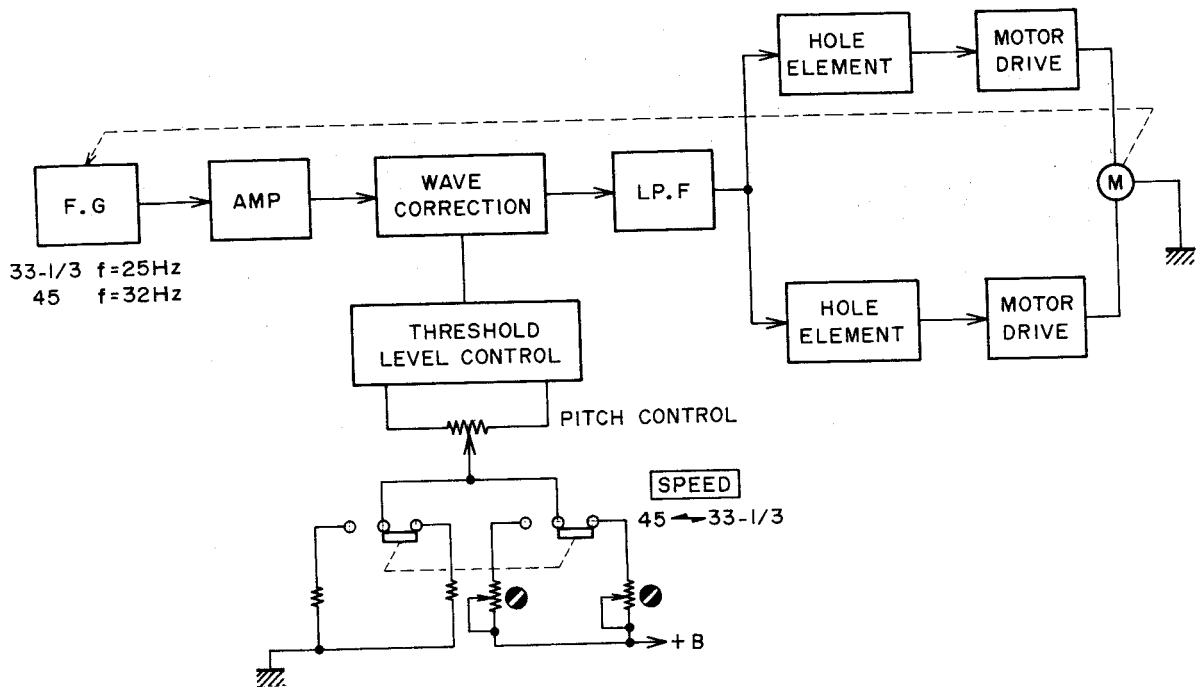

## 2. MODEL AP-Q50/C

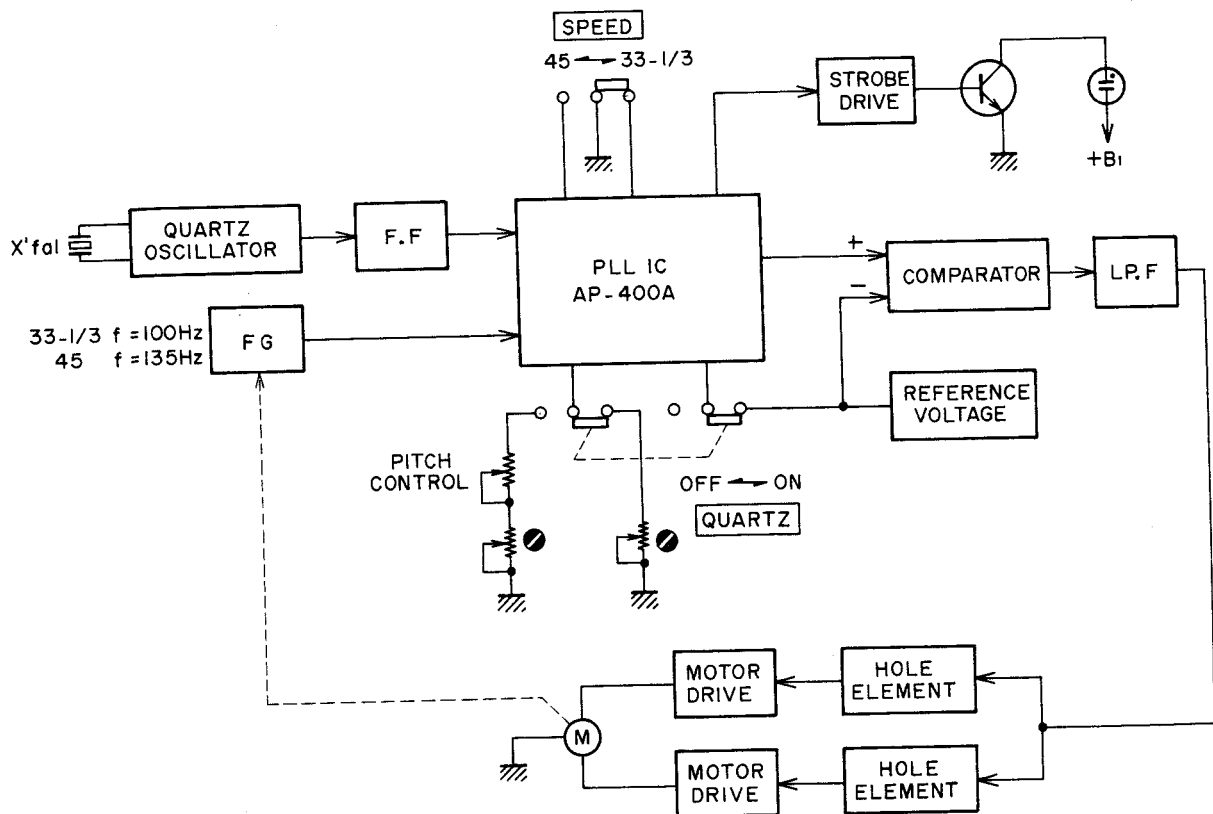

# VII. EXPLANATION OF HOW THE DC BRUSHLESS DD MOTOR WORKS

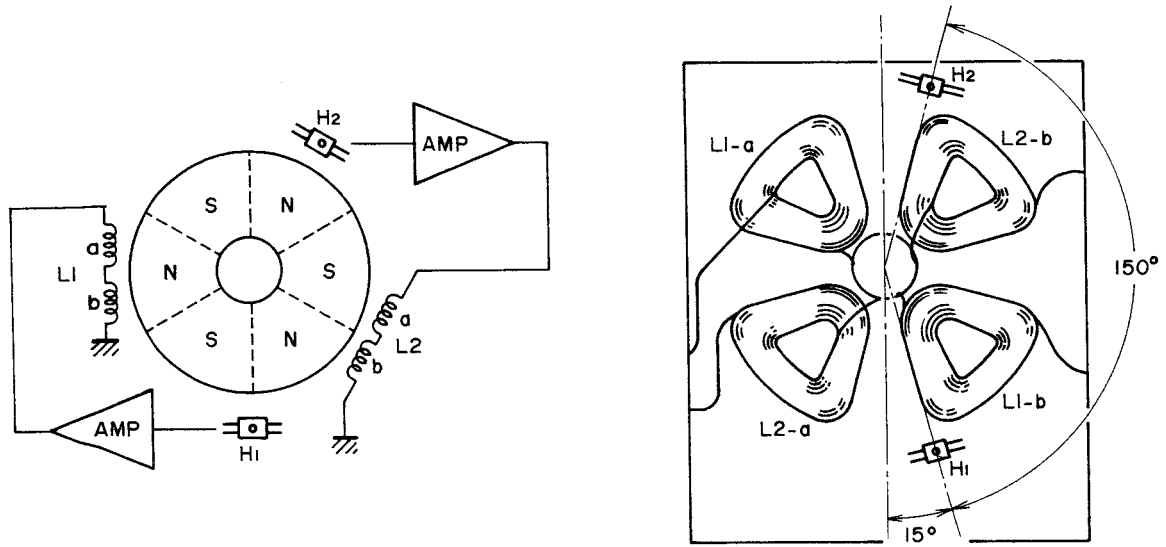

Fig. 8 Relative Positions of the coils, Magnet and Hall Elements

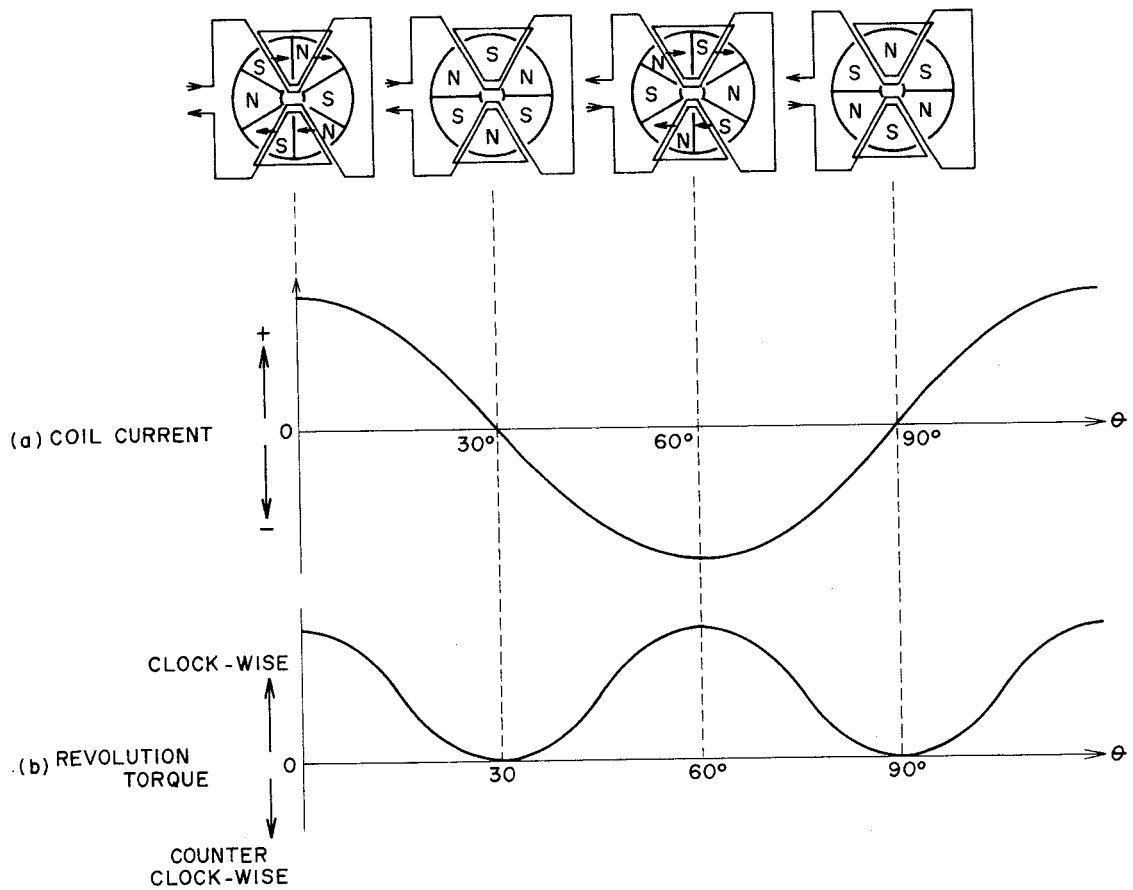

Fig. 9 Revolution Torque vs Magnet Polarity Position at one Phase

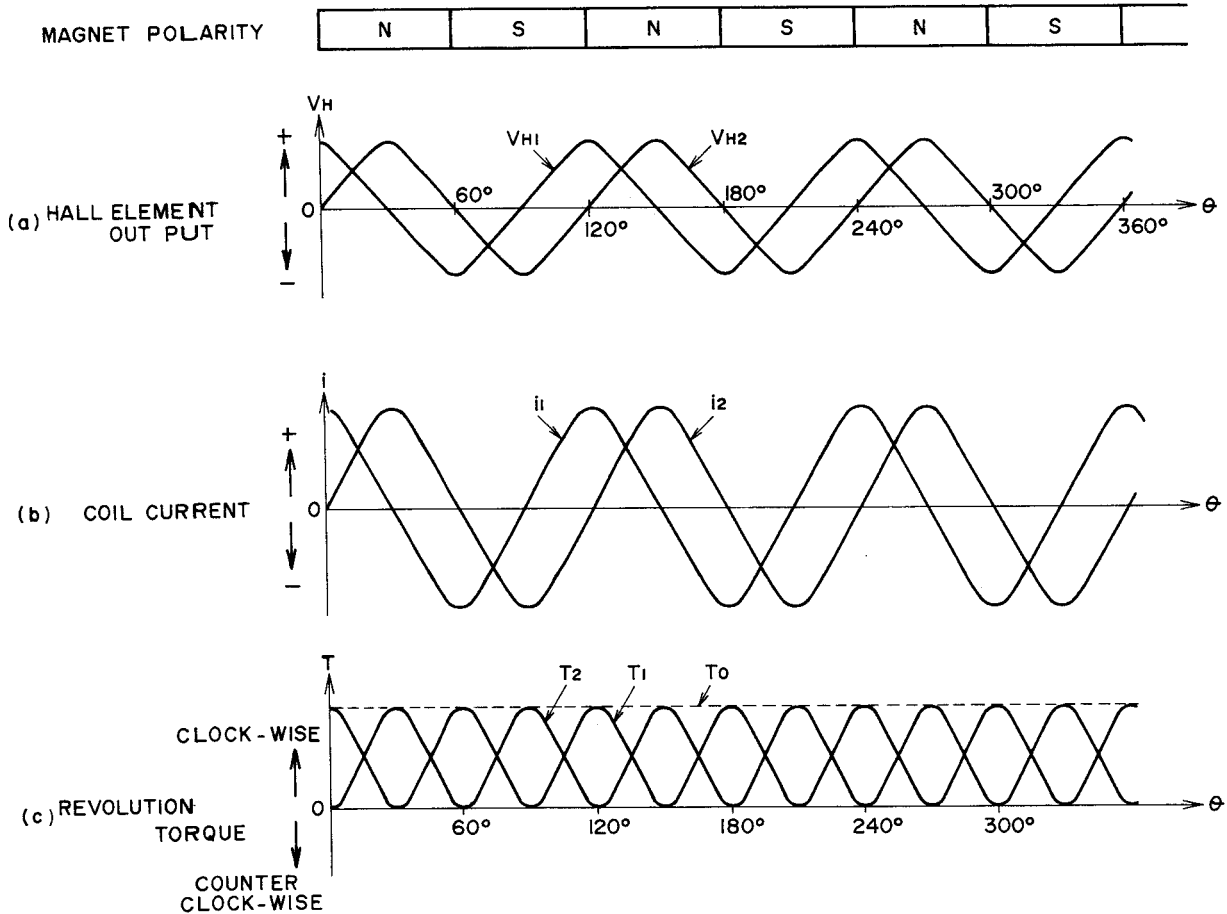

Fig. 10 Each Output Waveform vs Position of Magnetic Polarity

Fig. 8 shows the 4 coils and the 2 Hall elements on the base board. Fig. 8 (a) shows the motor drive system and the magnet which face the coils. The magnet is magnetized into 6 poles arranged alternately N/S.

Changes in the sine wave's magnetic field which accompanies revolution of the magnet are detected by the Hall elements, amplified by an amplifier generating torque which is supplied to the coil and then the magnet revolves. When sine wave current flows into the coil, with  $\theta$  as the revolution angle and  $K$  as a fixed value, the torque force  $T_1$  is:

$$T_1 = K \cdot i_1 \sin 3\theta \dots \dots \dots (1)$$

the coil current  $i_1$  with  $I$  as a fixed value is:

$$i_1 = I \cdot \sin 3\theta \dots \dots \dots (2)$$

so from 1 and 2:

$$T_1 = K \cdot I \cdot \sin^2 3\theta \dots \dots \dots (3)$$

Fig. 9 shows the changes in the coil current  $i_1$  and the torque  $T_1$  accompanying changes in the revolution angle  $\theta$ . A clockwise revolution torque is produced. Also the coil's other phase is out  $90^\circ$  electrically. As the phase of the magnetic field detected by the Hall element is also  $90^\circ$  out, the current flowing to this coil is:

$$i_2 = I \cdot \cos 3\theta \dots \dots \dots (4)$$

the generated torque  $T_2$  is

$$T_2 = K \cdot i_2 \cos 3\theta \dots \dots \dots (5)$$

so from 4 and 5, :

$$T_2 = K \cdot I \cdot \cos^2 3\theta \dots \dots \dots (6)$$

Fig. 10 shows the relationship between the output from the two Hall elements, current  $i_1$  and  $i_2$ , and the generated torque  $T_1$  and  $T_2$ .

The total torque generated is the sum of torques  $T_1$  and  $T_2$ . This torque  $T_0$  is

$$T_0 = T_1 + T_2 = K \cdot I (\sin^2 3\theta + \cos^2 3\theta) = K \cdot I$$

As shown in Fig. 10,  $T_0$  is fixed regardless of the revolution angle  $\theta$ .

## VIII. EXPLANATION OF HOW THE SERVO CIRCUITRY WORKS

### 1. MODEL AP-D30/C

(Refer to the schematic diagram)

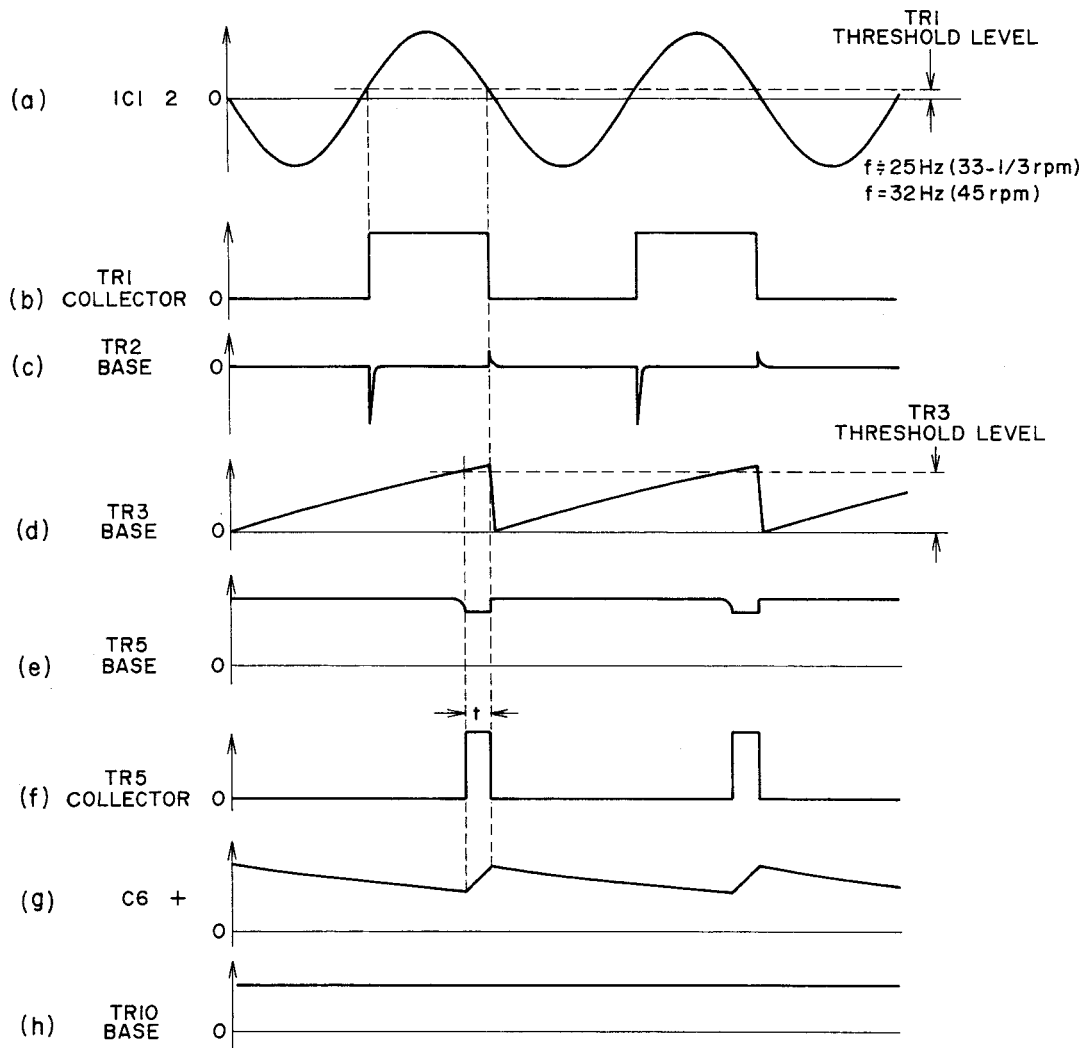

Fig. 11

The FG signal obtained from the motor block print coil is amplified by IC1 and added to TR1's base. When the FG signal passes TR1's threshold level, TR1 goes on and waveform (b) appears in the collector. Differentiated by C4 and R7, the positive pulse of the differential signal turns on TR2. As a result the integral waveform of waveform (d), with C5's current curve, appears in TR3's base. TR3 only goes on once the threshold level of waveform (d) has been passed and then waveform (f) appears in TR5's collector. The voltage of C6's two terminals is as with the waveform (g). This is because current flows in C6 during the period of waveform (f) only, regardless. This signal (waveform g) passes IC1's low pass filter, makes a DC control signal and becomes TR10's bias voltage. As a result, collector current flows into TR10 and control current into the Hall elements H1 and H2.

When the speed is faster than fixed, the period of FG signal shortens and the pulse width  $t$  decreases. Consequently waveform (g)'s voltage drops as does the base bias of TR10. Then the current to the Hall elements is reduced, the motor torque is weakened and the speed slows down, or in other words the speed of revolution is maintained at a fixed rate. When the speed slows, the period of FG signal lengthens and the pulse width  $t$  increases. Then the current in the Hall elements is increased, and the motor torque strengthened. In this way, the speed is controlled at a fixed rate. Pitch control is the changing of TR3's emitter potential by the changes of TR4's base bias. As a result, the threshold level of waveform (d) is raised and the pulse width changed. In this way, the Hall element current can be controlled and the speed changed.



2. MODEL AP-Q50/C  
(Refer to Schematic Diagram)

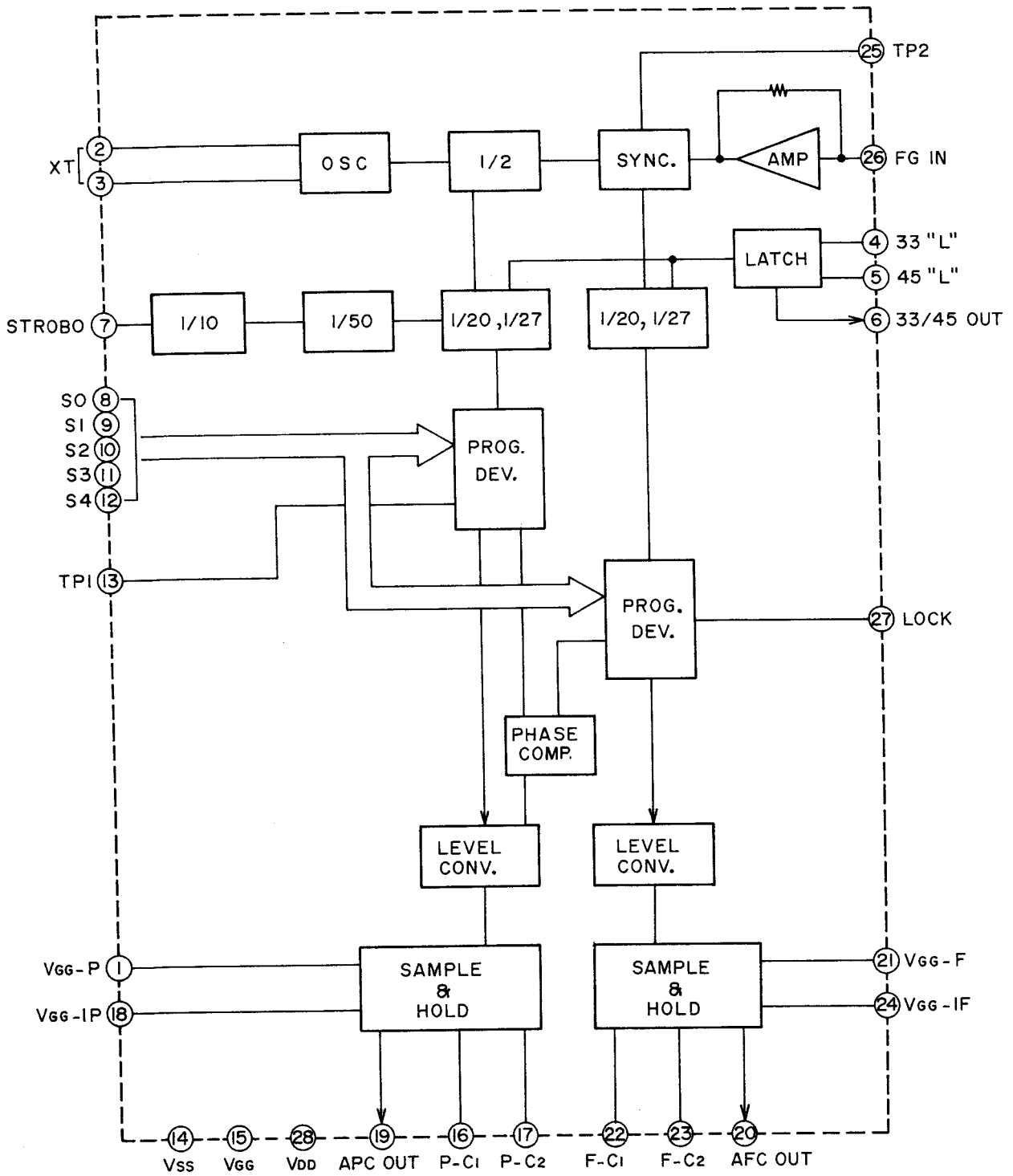

Fig. 12

Name	Terminal No.	Operation Mode
VGG-P	1	Supply terminal giving a high level of output voltage for APC-OUT.
XT	2, 3	Terminal connecting 2.7 MHz X'tal at FG = 180 pulses/1 revolution.
33 IN 45 IN	4 5	Terminal selecting the speed, has built-in pull up resistors becoming active at "L" level.
33/45 OUT	6	Becomes "L" level when set to 33-1/3 rpm.
STROBE	7	Strobe signal output terminal and duty is 1/10. Output frequency is the same as that of the input pulse FG-IN from the motor when the speed is accurate.
S <sub>0</sub> ~ S <sub>4</sub>	8 ~ 12	Input signal terminal for minute adjustment. 32 step speed control possible in steps of 0.2% by 5 bit binary code.
TP1	13	Test point at APC sampling signal output terminal.
VSS	14	GND terminal.
VGG	15	Supply terminal 12V $\pm$ 1V / $\pm$ 2V
PC <sub>1</sub>	16	Terminal for condenser connection to generate APC circuit saw waves.
PC <sub>2</sub>	17	Terminal for condenser correction to store APC sampling voltage.
VGG-IP	18	Terminal to control APC circuit saw wave tilt.
APC-OUT	19	APC output voltage terminal.
AFC-OUT	20	AFC output voltage terminal.
VGG-F	21	Supply terminal giving a high level of output voltage for AFC-OUT.
F-C <sub>1</sub>	22	Terminal for condenser connection to generate AFC circuit saw waves.
F-C <sub>2</sub>	23	Terminal for condenser connection to store AFC sampling voltage.
VGG-IF	24	Terminal to control AFC circuit saw wave tilt.
TP2	25	Test point at AFC sampling signal output terminal.
FG-IN	26	Terminal inputting pulses to correspond to motor speed.
LOCK	27	Outputs "L" level when the motor is PLL locked. Inside is an open in MOS FET and the LEDs can be directly driven.
VDD	28	Supply terminal 5V $\pm$ 0.5V.

Chart-1

The AP-Q50 has a photo sensor which picks up the FG signal from the stroboscope pattern on the underside of the platter in order to detect the speed. The servo circuit also employs PLL LSI AP-400A for motor control and it is a quartz lock system. AP-400A is an N channel silicon gate MOS type LSI which has been developed for speed control of quartz lock DD motors.

In Fig. 12's block diagram and Chart 1, the relationship between the terminal signal and operation mode is shown. AP-400A outputs voltage proportionate to the number of revolutions (AFC-OUT), and voltage proportionate to the phase (APC-OUT).

The FG signal input from the FG sensor enters the base of TR2, is rectified and then enters AP-400A's FG IN terminal. Next there is a 5.4 MHz oscillation by C1 and the X'tal (5.4 MHz) which is scaled down to 1/2 by the T-Flip Flop. This scaled down signal of 2.7 MHz is the

standard frequency and is input into AP-400A's XT terminal.

A voltage proportionate to the number of revolutions is put out from AFC-OUT and another voltage proportionate to the phase appears in APC-OUT due to AP-400A. When the quartz lock is on, these AFC-OUT and APC-OUT voltages are compared and amplified. Next they pass a low pass filter and are made into a DC control signal of the TR6's base bias. As a result, the collector current flows and the Hall element current is controlled.

When the quartz lock is off, a standard voltage from R26 and R27 and the AFC-OUT voltage are compared and amplified and the Hall element current is controlled. Pitch control controls the speed, changing the AFC-OUT voltage by changing the VGG-F addition voltage.

# IX. MECHANICAL ADJUSTMENT

## 1. STYLUS PRESSURE ADJUSTMENT

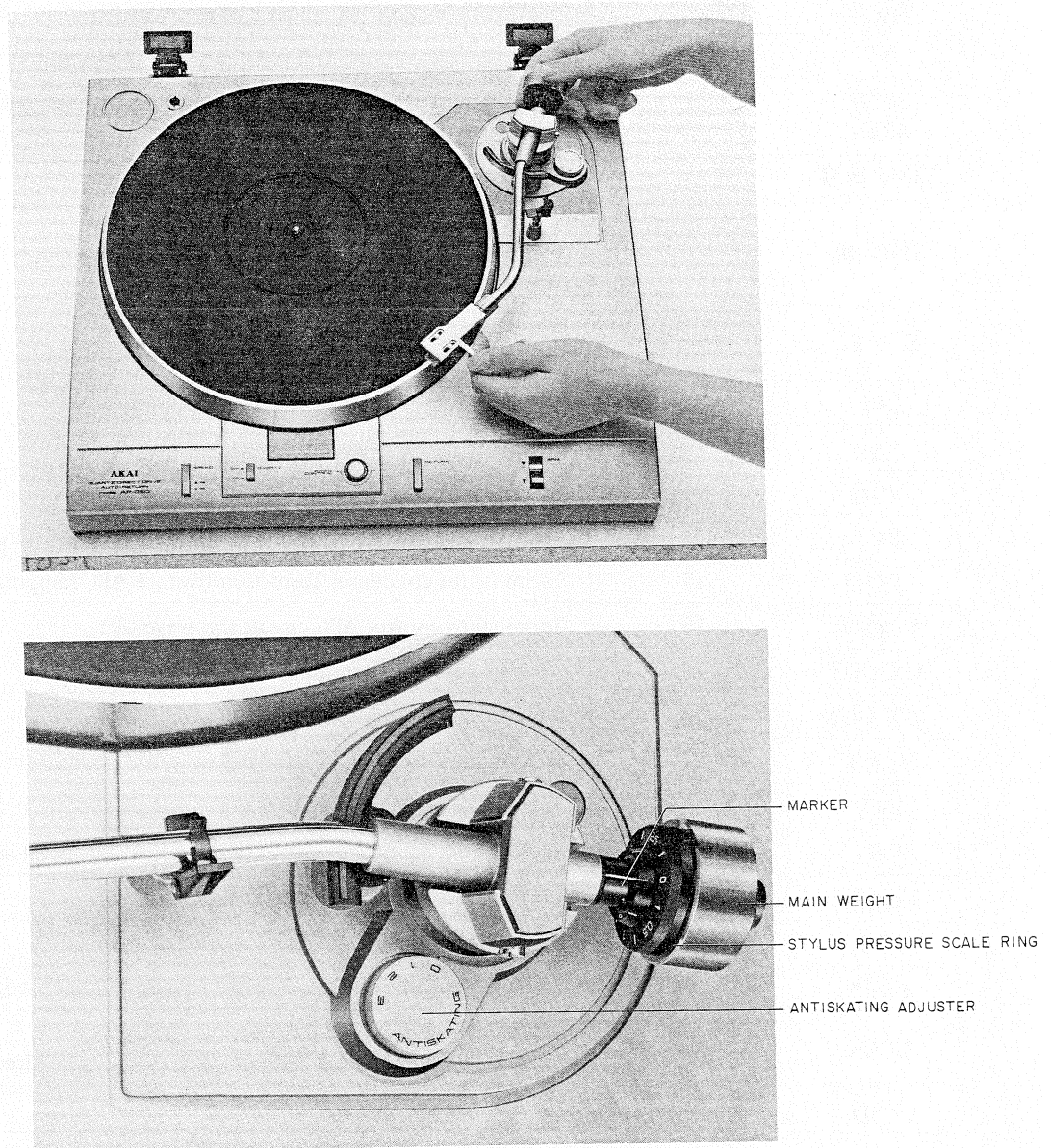

Fig. 13 Stylus Pressure Adjustment

1. Disconnect the Power Cord.
  2. Set the Tone Arm Lifter switch to  $\nabla$ .
  3. Bring the Tone Arm to a position between the turntable and the Tone Arm Rest without touching either.
  4. Rotate Main Weight backwards and forwards until the Tone Arm is in perfect horizontal balance. (Zero balance is attained.)
- CAUTION 1. Be sure that Anti-skating Adjuster is set to zero.
2. Remove the stylus guard and be careful nor to damage the stylus.
  5. Without moving the Main Weight, turn only the Stylus Pressure Scale Ring to match the "0" mark with the marker on the weight shaft. (Refer to Fig. 13)

6. Turn Main Weight counter-clockwise (as viewed from the front) with the Stylus Pressure Scale Ring until the marker on the weight shaft corresponds to the desired stylus pressure on the scale.

NOTE 1. AP-D30, AP-Q50 Black and Silver Panel Models do not come equipped with Cartridges.

2. The recommended stylus pressure for the supplied stylus (AP-D30C, AP-Q50C only), RS-90 is 2 grams. However, in the case of outside interference, more pressure may be needed for stability. The range of adjustment is from 0 to 3 grams.
7. Set the Anti-skating adjuster to correspond with the stylus pressure. (Fine adjust if necessary.)

## 2. OVERHANG ADJUSTMENT

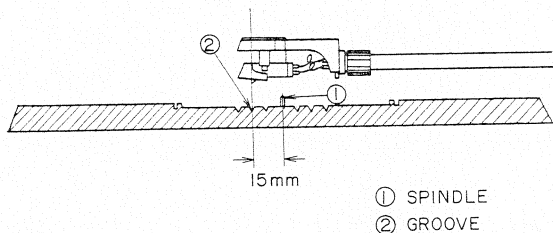
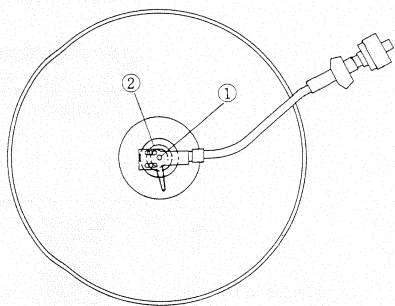
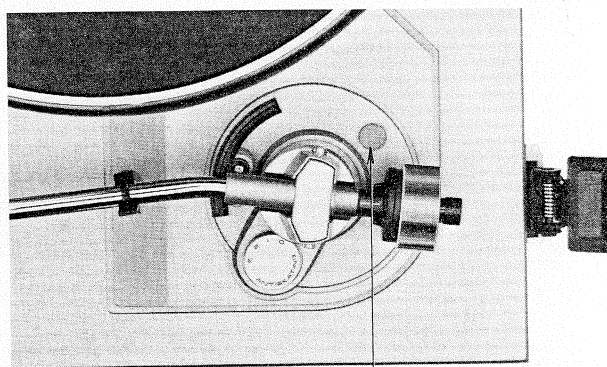
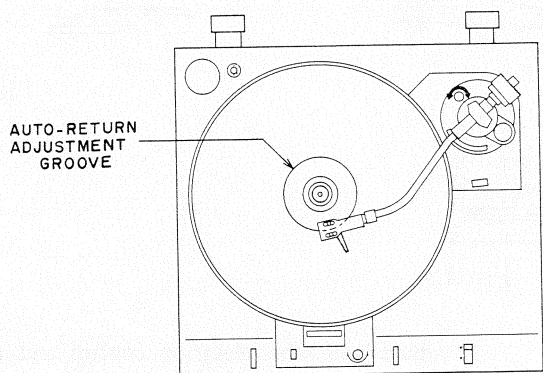

Fig. 14 Overhang Adjustment

The distance from the turntable shaft to the stylus when the Tone Arm is at the center of the turntable is called overhang. Although overhang is preset at the factory for this model, when the cartridge is replaced, adjustment may be necessary. For your convenience, the rubber turntable mat has an indicator groove at the center for easy overhang adjustment.

Bring the Tone Arm to the center of the turntable. Adjust the cartridge position in the cartridge shell so that the stylus position is even with the middle groove ring at overhang adjustment position. The cartridge position is adjustable by resetting the screws of the cartridge shell.

## 3. AUTO-RETURN ADJUSTMENT



AUTORETURN ADJUSTMENT SCREW CAP

Fig. 15 Auto-Return Adjustment

1. Disconnect the Power Cord.
2. Set the Tone Arm to Tone Arm Rest.
3. Remove the auto-return adjustment screw cap.
4. Adjust screw (a).
5. Place the tone arm above the separate raised ridge on the rubber mat.
6. Connect the Power Cord.
7. A clicking sound indicates that the auto-return has been successfully adjusted.
8. If you do not hear this clicking sound, repeat the whole procedure until you do.

#### 4. ARM LIFTER ADJUSTMENT

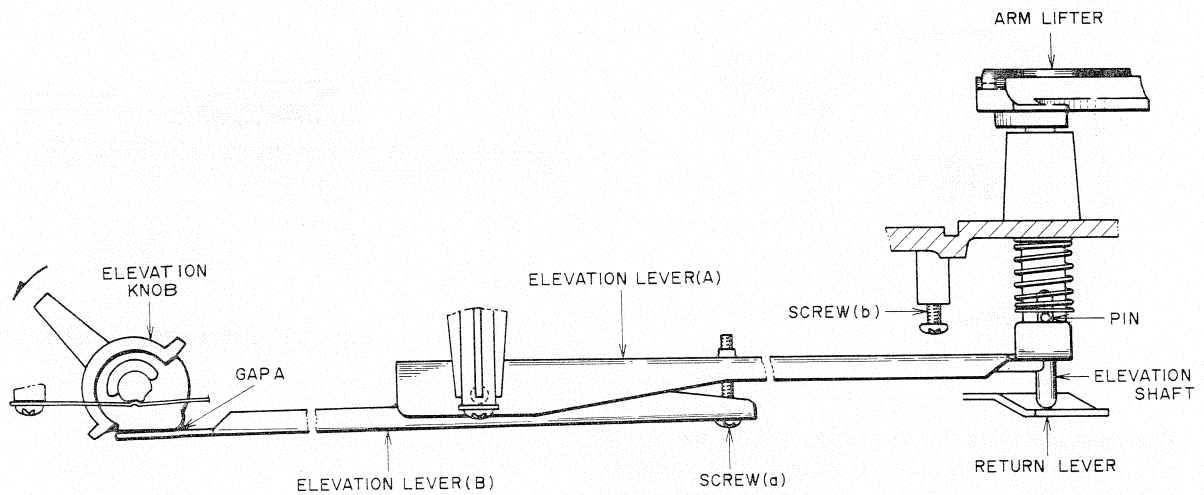

Fig. 16

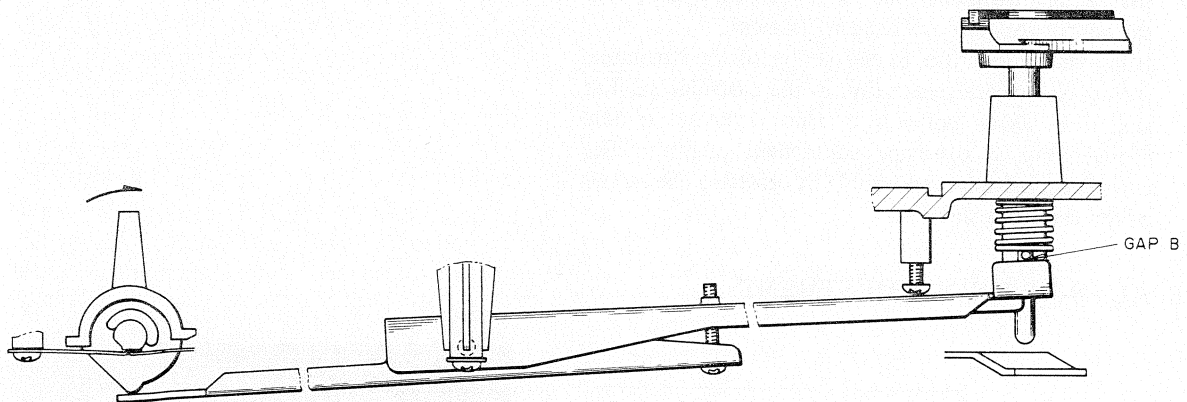

Fig. 17

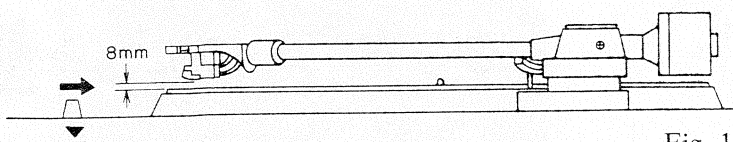

Fig. 18

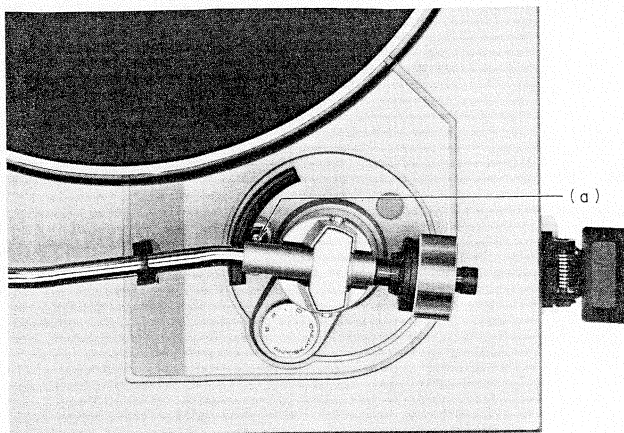

Fig. 19

1. Adjust with the elevation control and the arm lifter should be down. Confirm that the elevation shaft and lifter lever are touching. If not, press the arm lifter down with one finger until they do. Adjust screw (a) at exactly the point where the gap A between the elevation lever (B) and the elevation control disappears. (Refer to Fig. 16).
2. Next operate the auto return (turn the main gear by hand) and raise the arm lifter. With the elevation control at ▼, adjust screw (b) at exactly the point where the gap (B) between the shaft pin and the elevation lever (A) disappears. (Refer to Fig. 17).
3. Put a record on and set the elevation control to ▼. Adjust screw (a) until there is an 8 mm gap between the tip of the stylus and the surface of the record. (Refer to Figs. 18, 19)

## 5. MUTE SWITCH INSTALLATION POSITION ADJUSTMENT

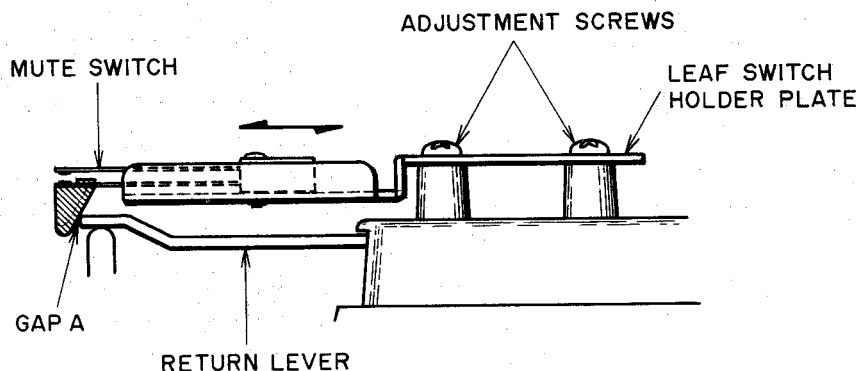

Fig. 20

With the auto return not in operation adjust the installation screw until the gap A between the return lever and the mute switch disappears. (Refer to Fig. 20).

## 6. RETURN PLUNGER INSTALLATION POSITION ADJUSTMENT

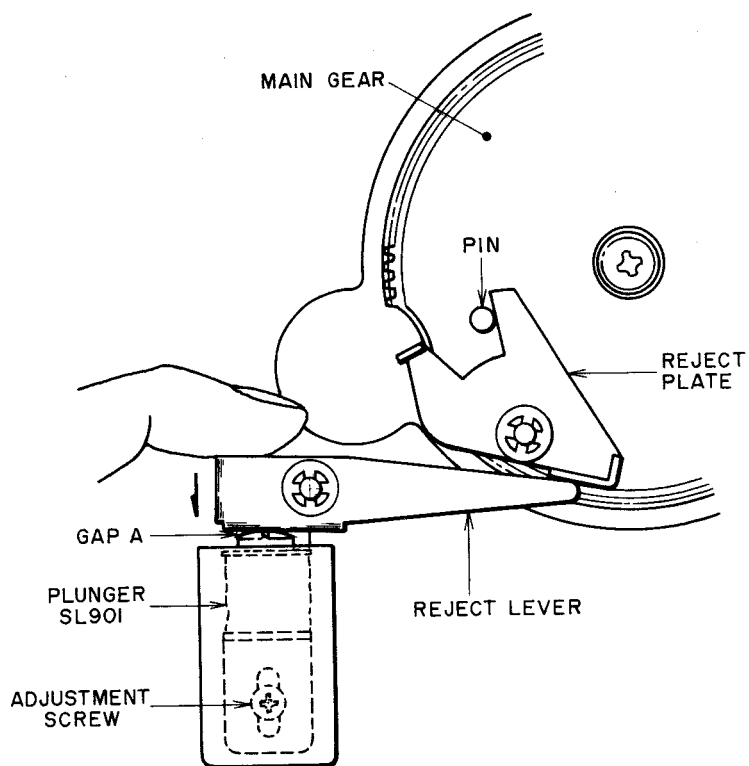

Fig. 21

Remove the motor block. Press the reject lever down with a finger until the reject plate touches the main gear pin. Operate the plunger (SL901) in this position and adjust the installation screw at exactly the point where the gap A between the reject lever and plunger disappears. (Refer to Fig. 21). After adjustment, confirm that the Auto-Return is operating.

# X. ELECTRICAL ADJUSTMENT

## 1. MODEL AP-D30/C

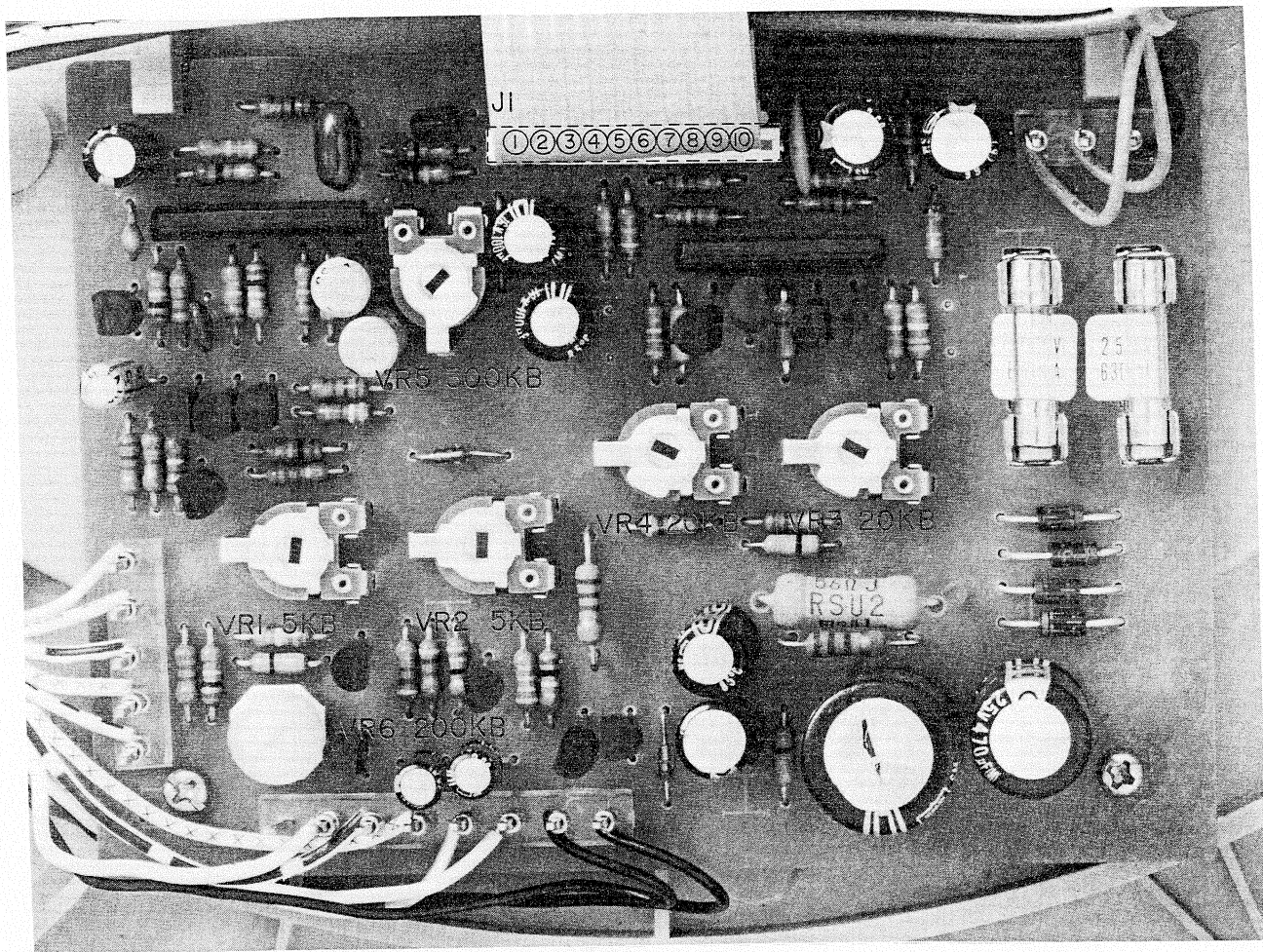

Fig. 22 D.D Servo P.C Board APD-3051

- 1) Off-set Voltage Adjustment (VR3, VR4) and Torque Difference Adjustment (VR5)
  - a) Disconnect the motor connection cord.
  - b) Short connector (J1) pins ③, ④ and ⑧.
  - c) Set VR5 (300 k $\Omega$ ) to the centre.
  - d) Move the Tone Arm and turn on the power.
  - e) Connect an oscilloscope to terminal ① of connector J1 and adjust VR3 (20 k $\Omega$ ) until it reads -100 mV DC.
  - f) Put the Tone Arm on the Arm Rest.
  - g) Short connector (J1) pins ⑥, ⑦ and ⑧.
  - h) Move the Tone Arm and turn on the power.
  - i) Connect an oscilloscope to terminal ② of connector J1 and adjust VR3 (20 k $\Omega$ ) until it reads -100 mV DC.
  - j) Put the Tone Arm on the Arm Rest and connect the motor connection wire to connector (J1).
  - k) Move the Tone Arm and turn on the power.
  - l) Connect an oscilloscope to ① and ② of connector (J1).  
Adjust VR5 (300 k $\Omega$ ) until the voltage is the same at both ① and ② terminals of connector (J1).
- 2) Speed Adjustment (VR1 and VR2)
  - a) Set the Speed Selector to 33-1/3 rpm.
  - b) Set the Pitch Control Volume to the centre.
  - c) Move the Tone Arm and turn on the power.
  - d) Adjust VR2 (5 k $\Omega$ ) until the strobe comes to a standstill.
  - e) Set the Speed selector to 45 rpm.
  - f) Adjust VR1 (5 k $\Omega$ ) until the strobe comes to a standstill.
- 3) Wow and Flutter Confirmation
  - a) Playback the test record (3,000 Hz).
  - b) Confirm that the Wow and Flutter is within 0.035% (JIS).
  - c) If not, adjust VR3, VR4 and VR5.
- 4) Return Sensor Adjustment (VR6)
 

NOTE Adjust Auto Return (Refer to IX-3) before making this Adjustment.

  - a) Playback the record.
  - b) Adjust VR6 (200 k $\Omega$ ) until the stylus is lifted up at an appropriate point the lead-out groove.

NOTE The range B of lead-out groove on which the stylus is to be lifted up is (Refer to Fig. 23).

  - \* 109 to 115 mm diameter for 30 and 25 cm disks.
  - \* 98 to 106 mm diameter for 17 cm disks.

CAUTION Do not use any disk or phono sheet other than the one complying with the JIS standard or equivalent disk for this adjustment.

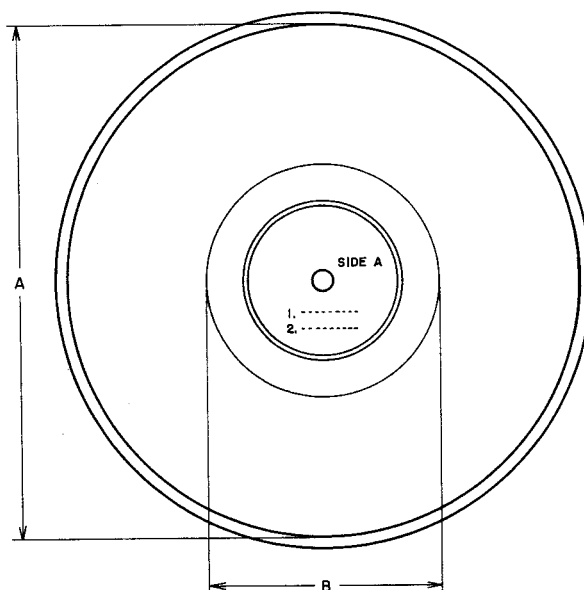

Fig. 23



## 2. MODEL AP-Q50/C

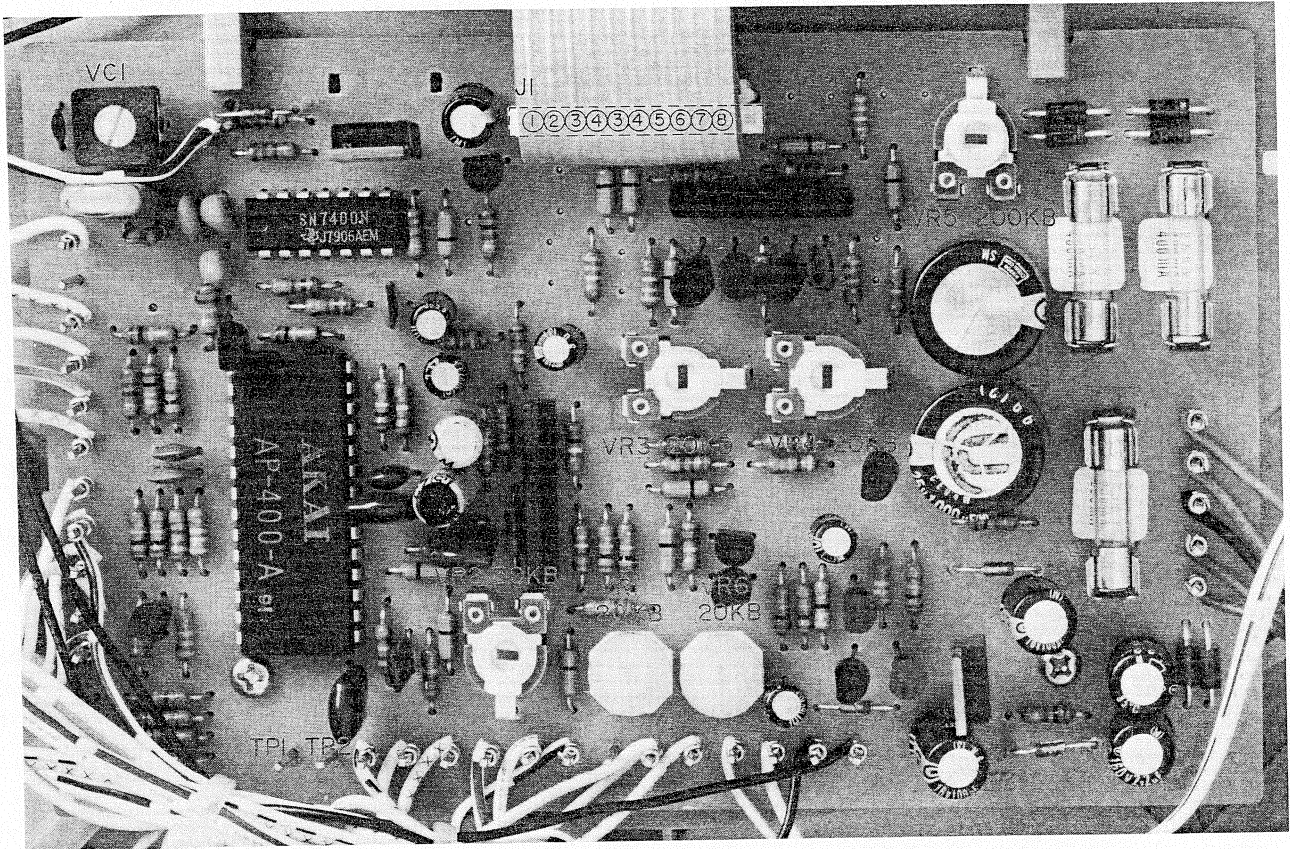

Fig. 24 Quartz Servo P.C Board APQ-5009

- 1) X'tal Oscillation Frequency Adjustment (VC1)
  - a) Connect a frequency counter to IC2's (AP-400-A) pin ② terminal.
  - b) Move the Tone Arm and turn the power on.
  - c) Adjust VC1 (15P) to give a frequency counter reading of 2.7 MHz  $\pm$ 10 Hz.
- 2) Off-set Voltage Adjustment (VR3, VR4) and Torque Difference Adjustment (VR5)
  - a) Disconnect the motor connection wire.
  - b) Short connector (J1) pins ③, ④ and ⑧.
  - c) Move the Tone Arm and turn on the power.
  - d) Connect an oscilloscope to pin ① terminal of connector (J1). Adjust VR3 20 kB until it reads -110 mV DC.
  - e) Put the Tone Arm on the Arm Rest. (Power is OFF).
  - f) Short connector (J1) pins ⑥, ⑦ and ⑧.
  - g) Set VR5 (200 kB) to the centre.
  - h) Move the Tone Arm and turn on the power.
  - i) Connect an oscilloscope to pin ② terminal of connector (J1) and adjust VR4 (20 kB) until it reads -110 mV DC.
  - j) Put the Tone Arm on the Arm Rest and connect the motor connection wire to the connector (J1).
  - k) Move the Tone Arm and turn on the power.
- 1) Connect an oscilloscope to ① and ② of connector (J1).  
Adjust VR5 (200 kB) until the voltage is the same at both ① and ② terminals of connector (J1).
- 3) Speed Adjustment (VR2)
  - a) Put the Quartz Switch to OFF.
  - b) Set the Speed Selector to 33-1/3 rpm.
  - c) Set the Pitch Control Volume to centre.
  - d) Move the Tone Arm and turn the power on.
  - e) Adjust VR2 (30 kB) until the strobe comes to a standstill.
- 4) Quartz-Locked Phase Angle Adjustment (VR1)
  - a) Put the Quartz Switch to ON.
  - b) Set the Speed Selector to 45 rpm.
  - c) Move the Tone Arm and turn on the power.
  - d) Connect CH-1 of an oscilloscope to TP1 and CH-2 to TP2.
  - e) Adjust VR1 (20 kB) until as in Fig. 25.

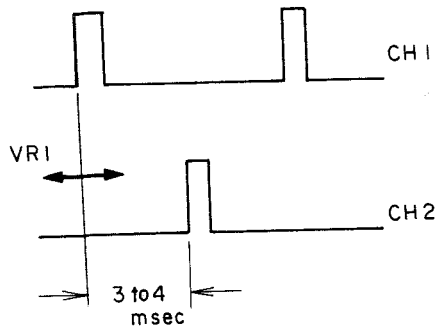

Fig. 25

5) Wow and Flutter Confirmation

- a) Put the Quartz Switch to OFF.
- b) Playback the test record (3,000 Hz).
- c) Check that the Wow and Flutter is to within 0.035% (JIS).
- e) If not, re-adjust VR3, VR4 and VR5.

6) Return Sensor Adjustment (VR6)

NOTE Adjust Auto Return (Refer to IX-3) before making this Adjustment.

- a) Playback the record.
- b) Adjust VR6 (200 kB) until the stylus is lifted up at an appropriate point the lead-out groove.

NOTE The range B of lead-out groove on which the stylus is to be lifted up is (Refer to Fig. 26).

\* 109 to 115 mm diameter for 30 and 25 cm disks.

\* 98 to 106 mm diameter for 17 disks.

**CAUTION** Do not use any disk or phono sheet other than the one complying with the JIS standard or equivalent disk for this adjustment.

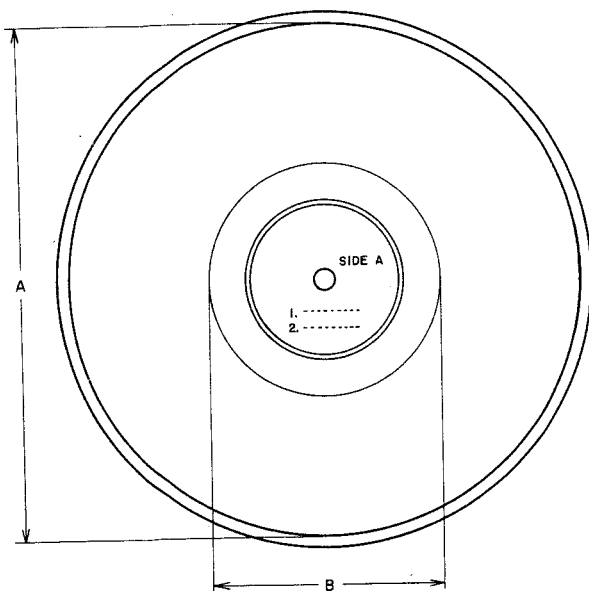

Fig. 26

# XI. CLASSIFICATION OF VARIOUS P.C BOARDS

## 1. P.C BOARD TITLE AND IDENTIFICATION NUMBER

### 1) Model AP-D30/C

P.C Board Title	P.C Board Number
D.D Servo P.C Board	APD-3051
Push Switch P.C Board	APD-3053
Intermediate P.C Board	APD-3054
Return Sensor P.C Board	APD-3055
Neon Lamp P.C Board	APD-3056
Fuse P.C Board (U/T)	APD-3052
Fuse P.C Board (CSA, AAL)	APD-3062
Fuse P.C Board (CEE, UK)	APD-3063

Chart-2

### 2) Model AP-Q50/C

P.C Board Title	P.C Board Number
Quartz Servo P.C Board	APQ-5009
Push Switch P.C Board	APD-3053
Intermediate P.C Board	APD-3054
Return Sensor P.C Board	APD-3055
Neon Lamp P.C Board	APQ-5010
LED P.C Board	APQ-5011
FG Sensor P.C Board	APQ-5012
Fuse P.C Board (U/T)	APD-3052
Fuse P.C Board (CSA)	APQ-5016
Fuse P.C. Board (AAL)	APQ-5014
Fuse P.C Board (CEE, UK)	APQ-5017

Chart-3

2. MODEL AP-D30/C COMPOSITION OF VARIOUS P.C BOARDS

1) D.D Servo P.C Board APD-3051, Return Sensor P.C Board APD-3055 and Push Switch P.C Board APD-3053

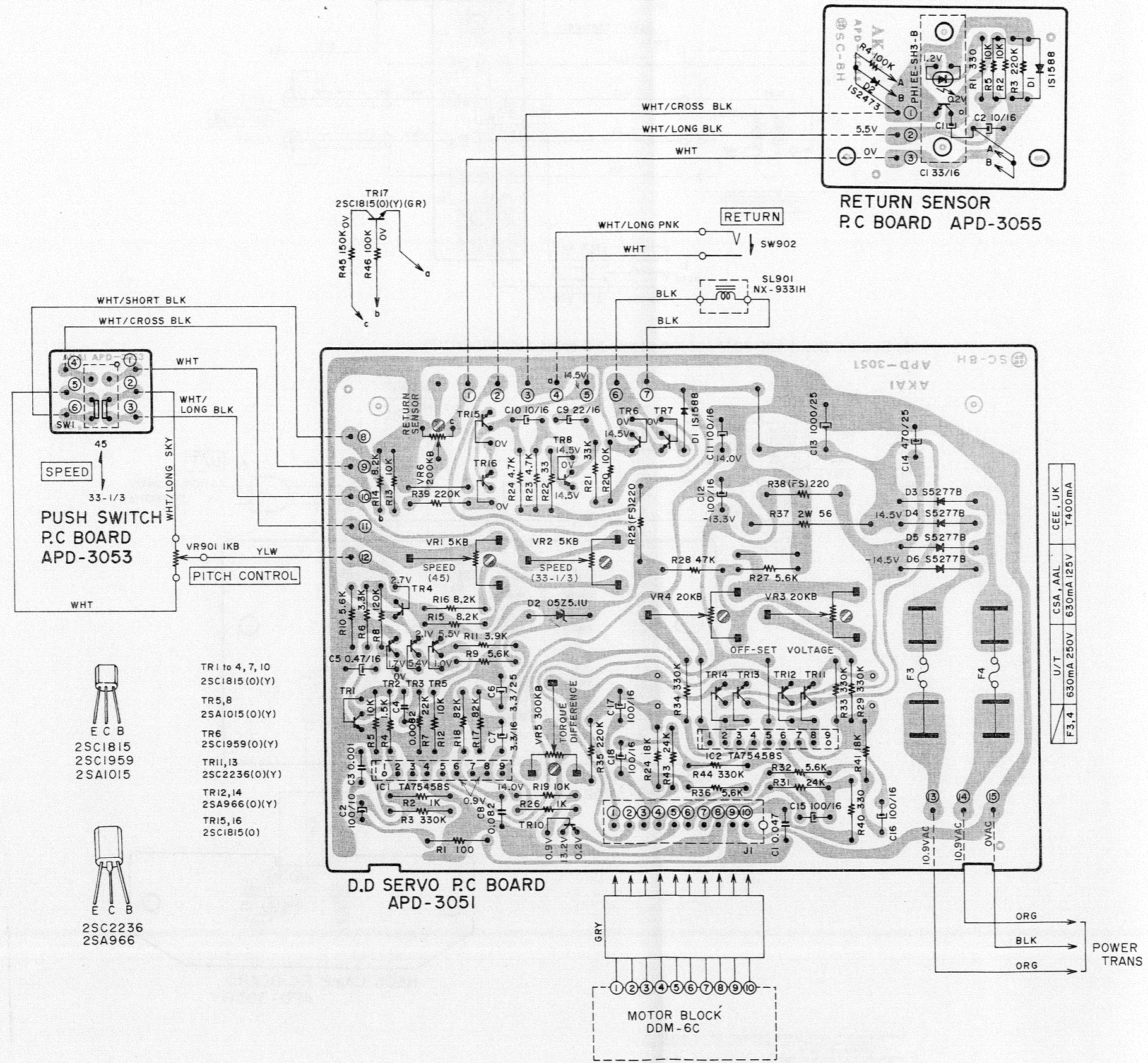

2) Intermediate P.C Board APD-3054

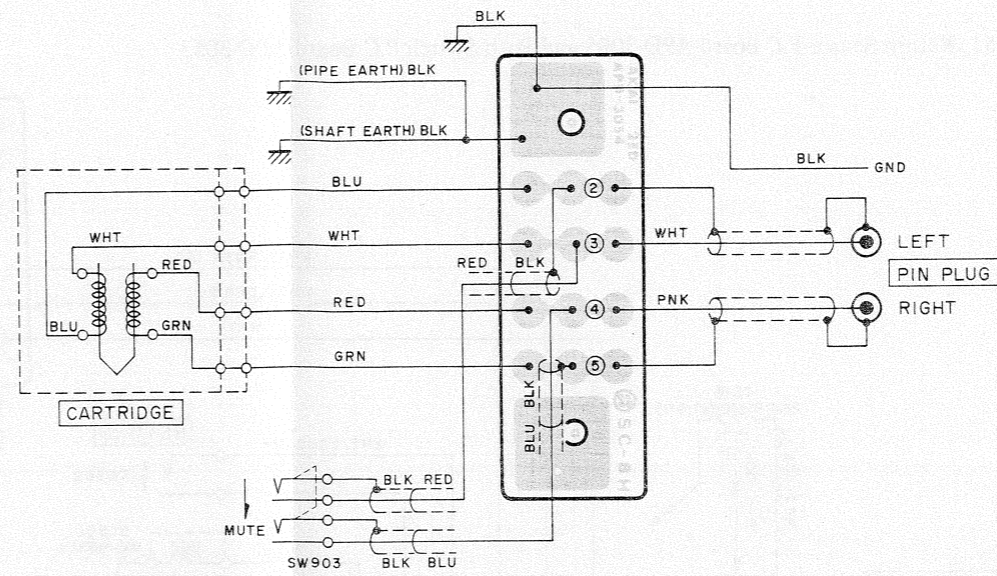

3) Fuse P.C Board APD-3052 and Neon Lamp P.C Board APD-3056 (U/T)

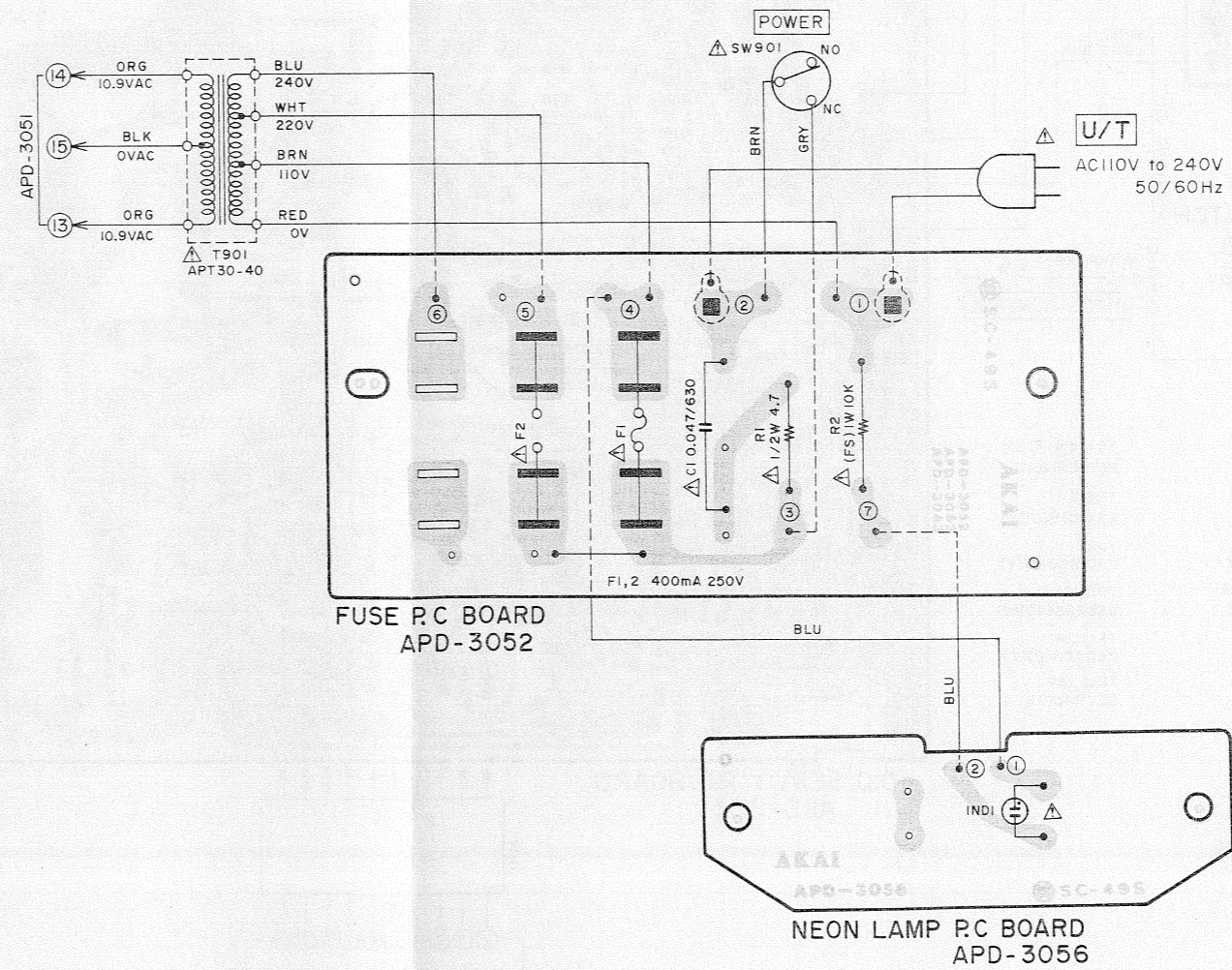

WARNING: Δ INDICATES SAFETY CRITICAL COMPONENTS. FOR CONTINUED SAFETY, REPLACE SAFETY CRITICAL COMPONENTS ONLY WITH MANUFACTURER'S RECOMMENDED PARTS.  
 AVERTISSEMENT: Δ ILL INDICU LES COMPOSANTS CRITIQUES DE SÛRETÉ. POUR MAINTENIR LE DEGRÉ DE SÛRETÉ DE L'APPAREIL, NE REMPLACER LES COMPOSANTS DONT LE FONCTIONNEMENT EST CRITIQUE QUE PAR DES PIÈCES RECOMMANDÉES PAR LE FABRICANT.

4) Fuse P.C Board APD-3062 and Neon Lamp P.C Board APD-3056 (CSA, AAL)

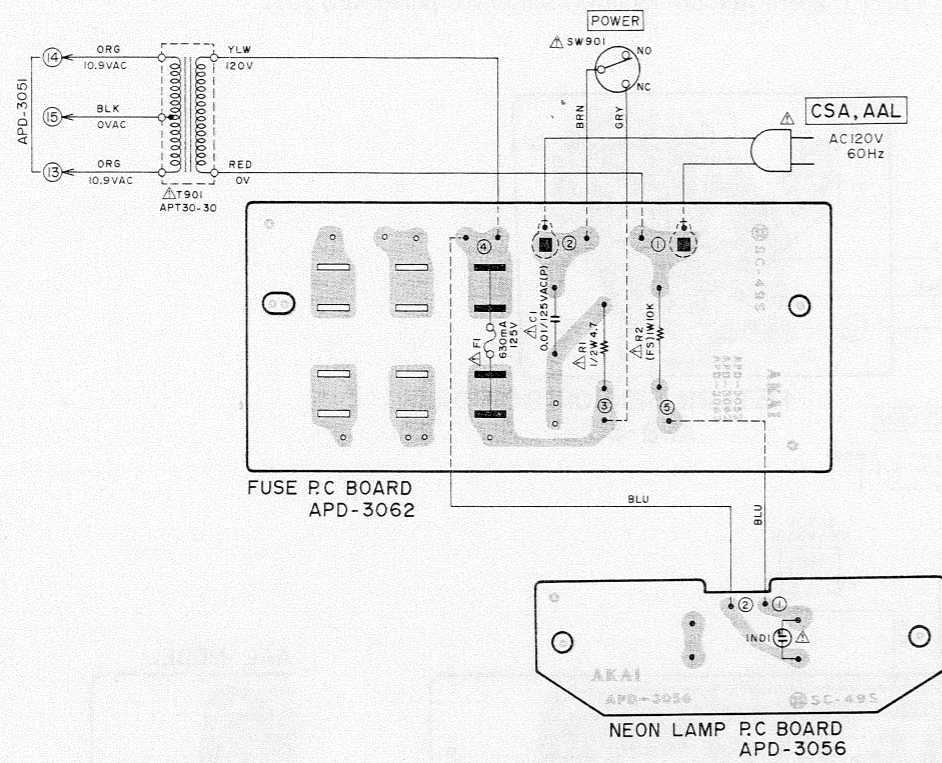

5) Fuse P.C Board APD-3063 and Neon Lamp P.C Board APD-3056 (CEE, UK)

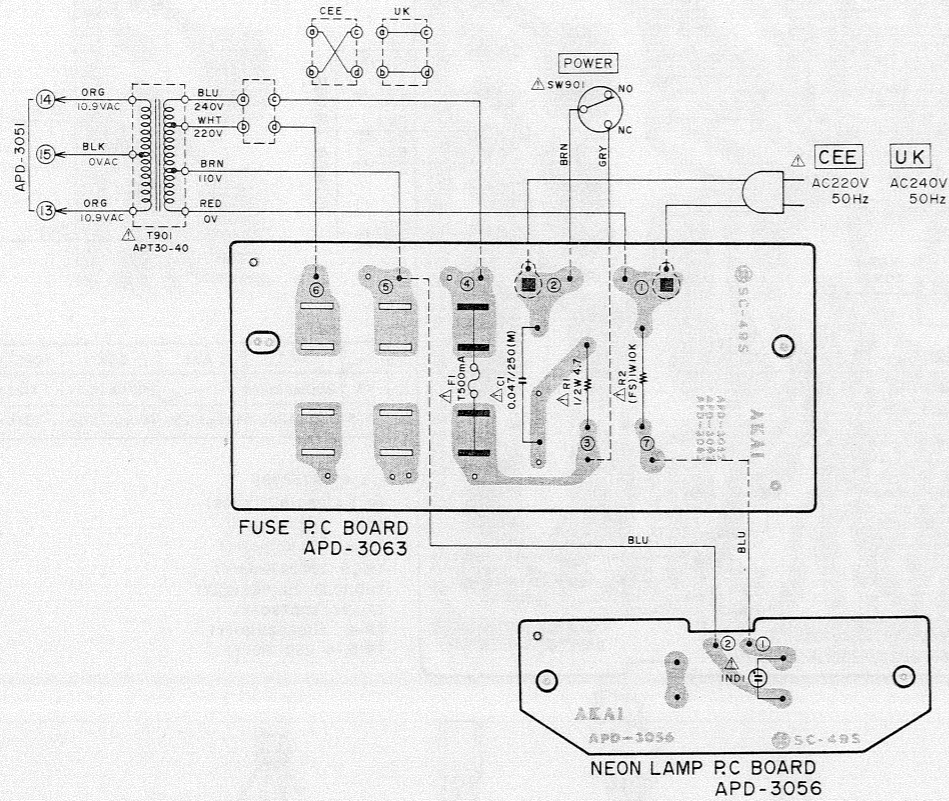

WARNING: Δ INDICATES SAFETY CRITICAL COMPONENTS. FOR CONTINUED SAFETY, REPLACE SAFETY CRITICAL COMPONENTS ONLY WITH MANUFACTURER'S RECOMMENDED PARTS.  
 AVERTISSEMENT: Δ IL INDIQUE LES COMPOSANTS CRITIQUES DE SÛRETÉ. POUR MAINTENIR LE DEGRÉ DE SÛRETÉ DE L'APPAREIL, NE REMPLACER LES COMPOSANTS DONT LE FONCTIONNEMENT EST CRITIQUE POUR LA SÛRETÉ QUE PAR DES PIÈCES RECOMMANDÉES PAR LE FABRICANT.

### 3. MODEL AP-Q50/C COMPOSITION OF VARIOUS P.C BOARDS

1) Quartz Servo P.C Board APQ-5009, Return Sensor P.C Board APD-3055, Push Switch P.C Board APD-3053, Neon Lamp P.C Board APQ-5010, LED P.C Board APQ-5011 and FG Sensor P.C Board APQ-5012.

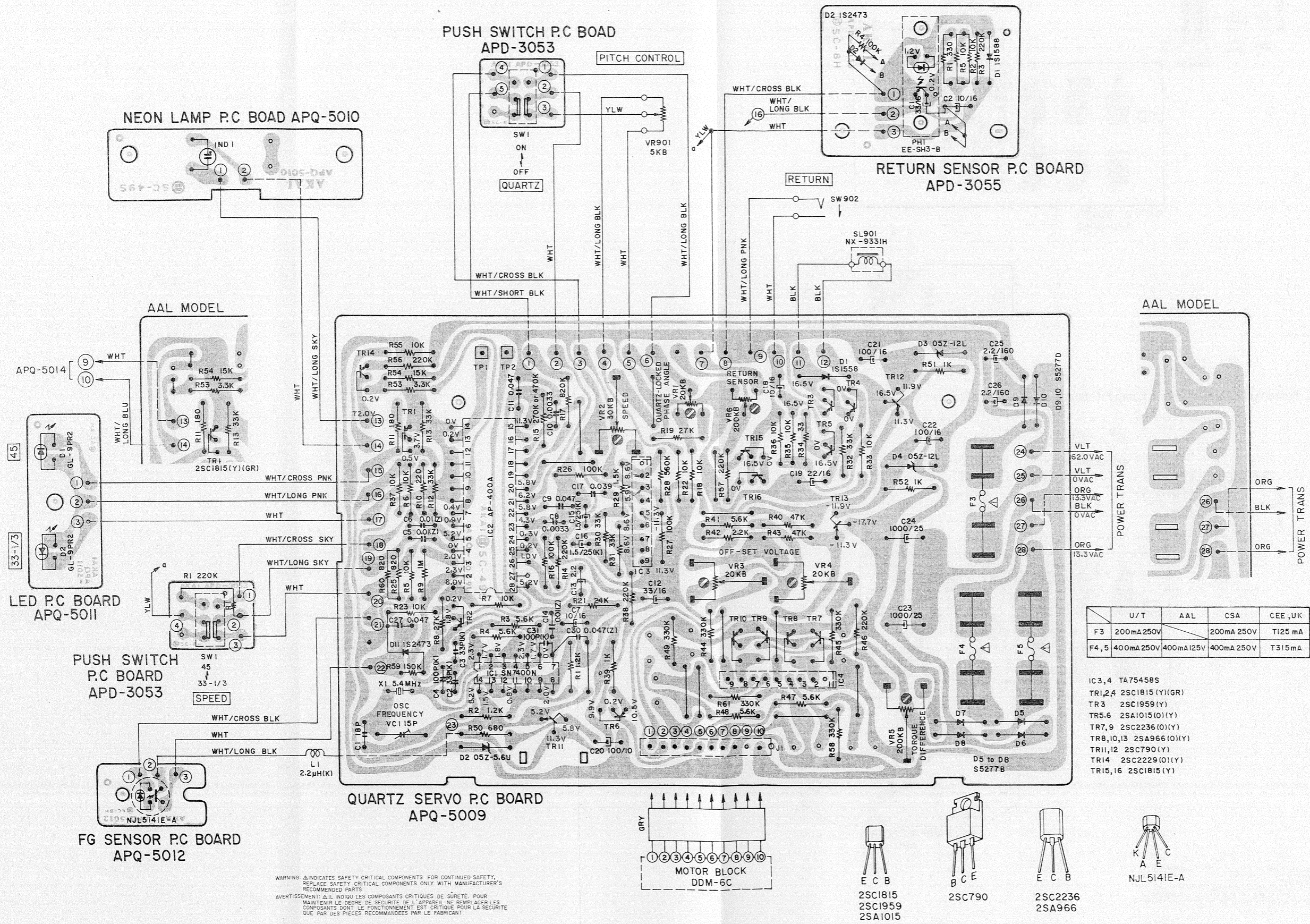

	U/T	AAL	CSA	CEE, UK
F3	200mA 250V		200mA 250V	T125 mA
F4, 5	400mA 250V	400mA 125V	400mA 250V	T315 mA

- IC3,4 TA75458S
- TR1,2,4 2SC1815(Y)(GR)
- TR3 2SC1959(Y)
- TR5,6 2SA1015(O)(Y)
- TR7,9 2SC2236(O)(Y)
- TR8,10,13 2SA966(O)(Y)
- TR11,12 2SC790(Y)
- TR14 2SC2229(O)(Y)
- TR15,16 2SC1815(Y)

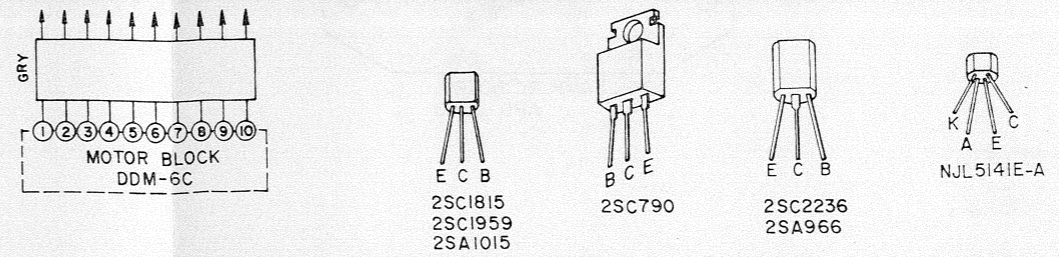

WARNING: INDICATES SAFETY CRITICAL COMPONENTS. FOR CONTINUED SAFETY, REPLACE SAFETY CRITICAL COMPONENTS ONLY WITH MANUFACTURER'S RECOMMENDED PARTS.  
 AVERTISSEMENT: IL INDIQUE LES COMPOSANTS CRITIQUES DE SÛRETÉ. POUR MAINTENIR LE DEGRÉ DE SÛRETÉ DE L'APPAREIL, NE REMPLACER LES COMPOSANTS DONT LE FONCTIONNEMENT EST CRITIQUE POUR LA SÛRETÉ QUE PAR DES PIÈCES RECOMMANDÉES PAR LE FABRICANT.

2) Intermediat e P.C Board APD-3054

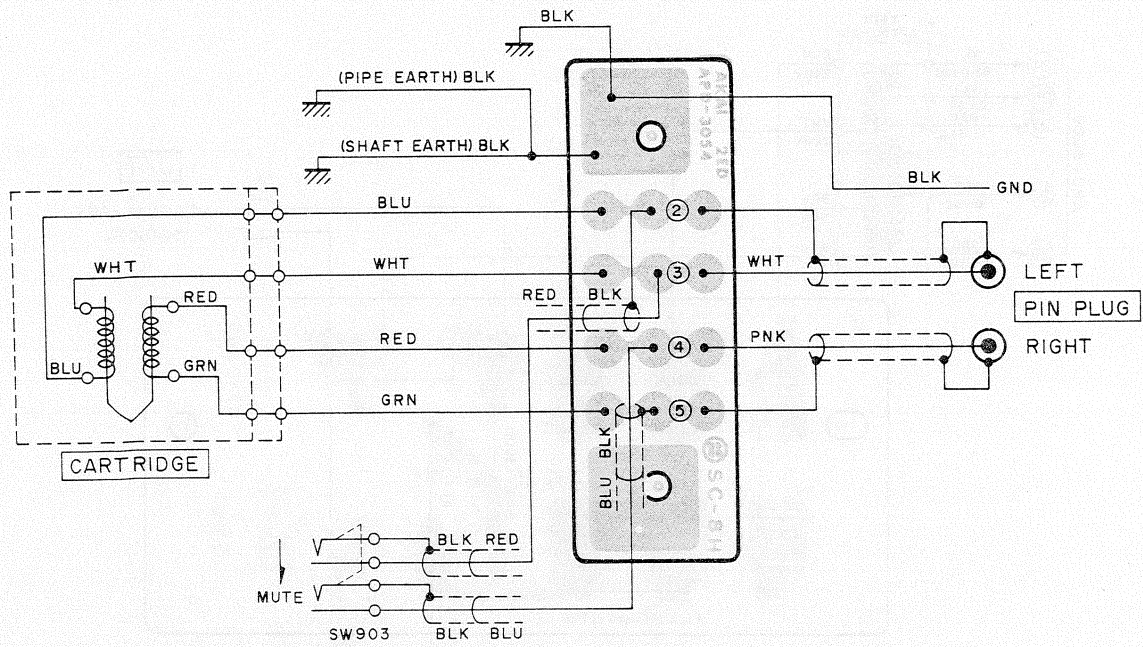



3) Fuse P.C Board APD-3052 (U/T)

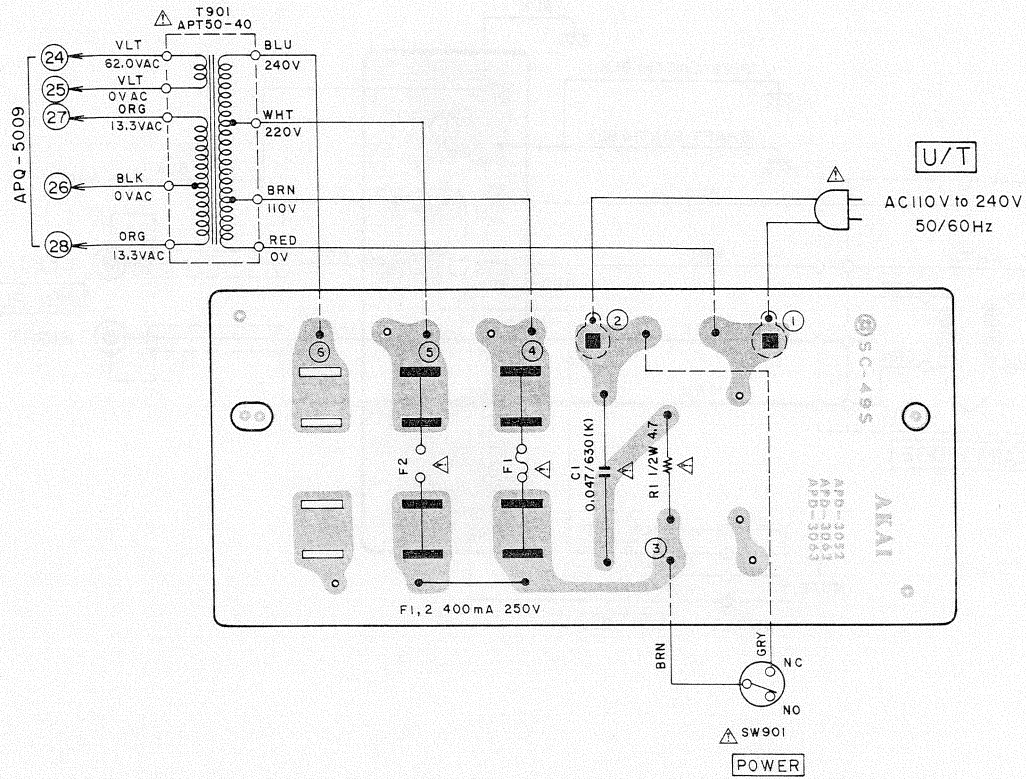

4) Fuse P.C Board APQ-5016 (2ED) (CSA)

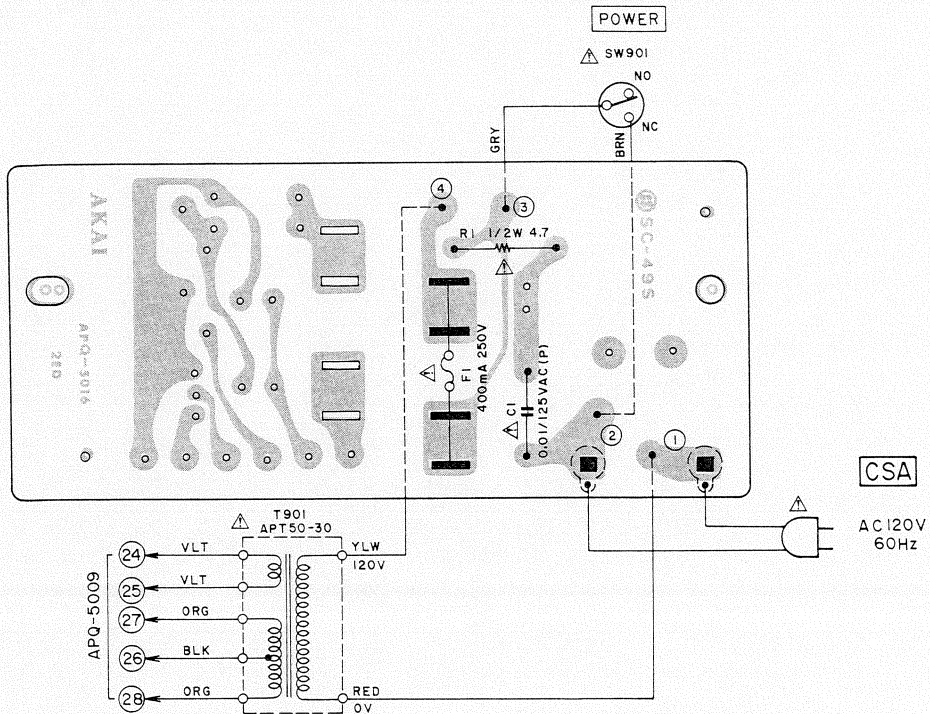

WARNING: ⚠ INDICATES SAFETY CRITICAL COMPONENTS. FOR CONTINUED SAFETY, REPLACE SAFETY CRITICAL COMPONENTS ONLY WITH MANUFACTURER'S RECOMMENDED PARTS.  
 AVERTISSEMENT: ⚠ IL INDIQUE LES COMPOSANTS CRITIQUES DE SÛRETÉ. POUR MAINTENIR LE DEGRÉ DE SÛRETÉ DE L'APPAREIL NE REMPLACER LES COMPOSANTS DONT LE FONCTIONNEMENT EST CRITIQUE POUR LA SÛRETÉ QUE PAR DES PIÈCES RECOMMANDÉES PAR LE FABRICANT.

5) Fuse P.C Board APQ-5017 (2ED) (CEE, UK)

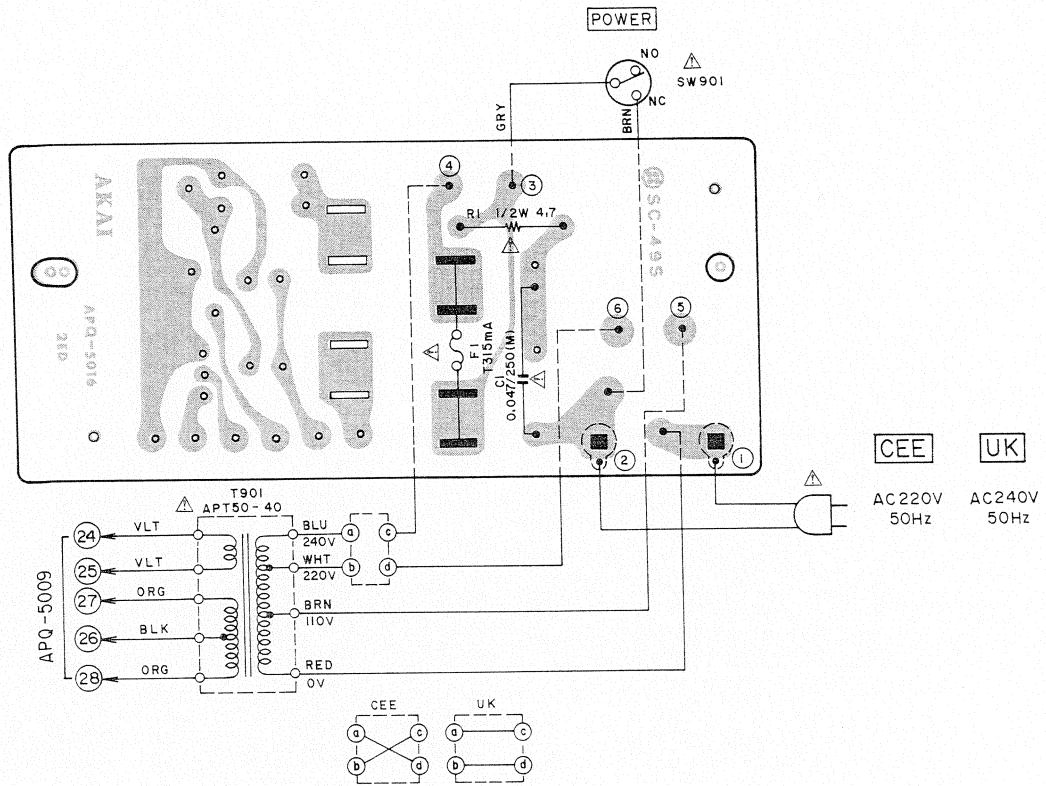

6) Fuse P.C Board APQ-5014 (2ED) (AAL)

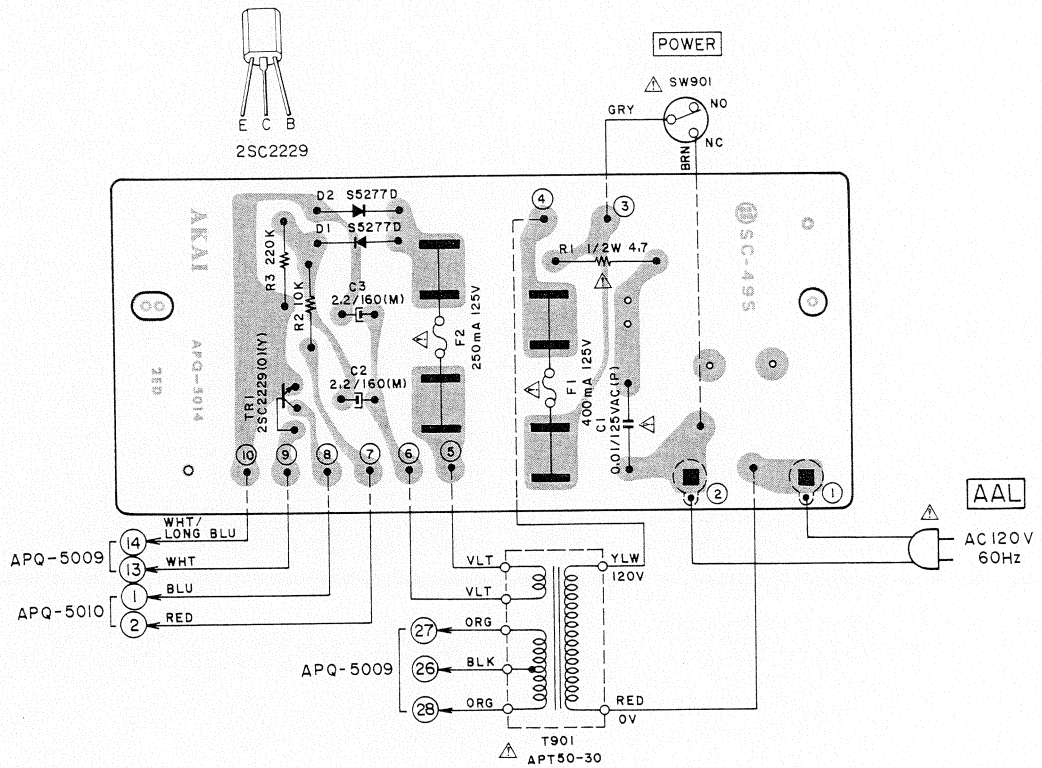

WARNING: Δ INDICATES SAFETY CRITICAL COMPONENTS. FOR CONTINUED SAFETY, REPLACE SAFETY CRITICAL COMPONENTS ONLY WITH MANUFACTURER'S RECOMMENDED PARTS.

AVERTISSEMENT: Δ ILL INDIQU LES COMPOSANTS CRITIQUES DE SÛRETÉ. POUR MAINTENIR LE DEGRÉ DE SÛRETÉ DE L'APPAREIL, NE REMPLACER LES COMPOSANTS DONT LE FONCTIONNEMENT EST CRITIQUE POUR LA SÛRETÉ QUE PAR DES PIÈCES RECOMMANDÉES PAR LE FABRICANT.



---

SECTION 2

**PARTS LIST**

TABLE OF CONTENTS

**I. MODEL AP-D30/C**

- 1. DD SERVO P.C BOARD (APD-3051) BLOCK . . . . . 38
- 2. RETURN SENSOR P.C BOARD (APD-3055) BLOCK . . . . . 38
- 3. FUSE P.C BOARD (APD-3052/3062/3063) BLOCK . . . . . 39
- 4. ASSEMBLY BLOCK (1) . . . . . 40
- 5. ASSEMBLY BLOCK (2) . . . . . 42
- 6. ASSEMBLY BLOCK (3) . . . . . 44

**II. MODEL AP-Q50/C**

- 1. QUARTZ SERVO P.C BOARD (APQ-5009) BLOCK . . . . . 45
- 2. RETURN SENSOR P.C BOARD BLOCK . . . . . 45
- 3. FUSE P.C BOARD (APD-3052/APQ-5014/5016/5017) BLOCK . . . . . 45
- 4. ASSEMBLY BLOCK (1) . . . . . 46
- 5. ASSEMBLY BLOCK (2) . . . . . 48
- 6. ASSEMBLY BLOCK (3) . . . . . 50

**INDEX . . . . . 51**

Resistor and Capacitor which is not listed in this parts list, please refer to  
**COMMON LIST FOR SERVICE PARTS.**

## HOW TO USE THIS PARTS LIST

1. This parts list is compiled by various individual blocks based on assembly process.
2. When ordering parts, please describe parts number, serial number, and model number in detail.
3. How to read list.

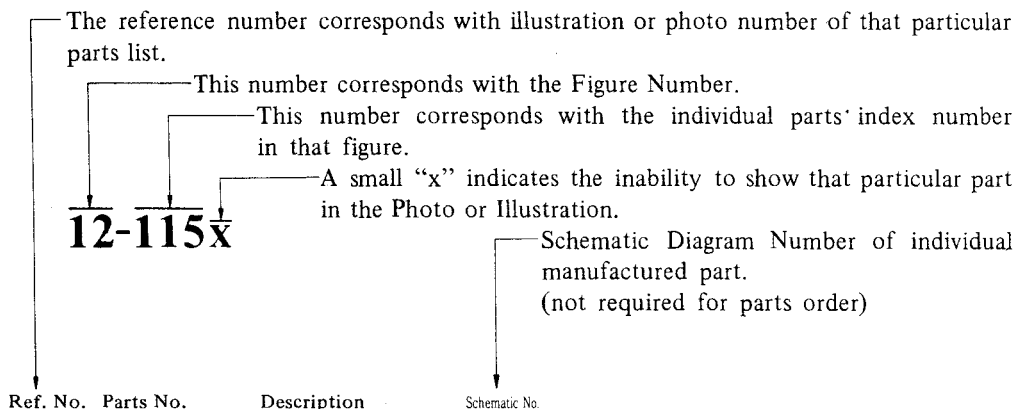

Ref. No.	Parts No.	Description	Schematic No.
<b>FLYWHEEL BLOCK #13</b>			
12-115x	800425	Flywheel Block Assy. Comp.	RDG #13
12-116	244506	Flywheel Only	RD-233
12-117x	244754	Felt, Flywheel	RD-275
12-118	251324	Main Metal Case	RD-236
12-119	253080	Main Metal	RD-237

4. The symbol numbers shown on the P.C. Board list can be matched with the Composite Views of components of the Schematic Diagram or Service Manual.
5. The indications of Resistors and Capacitors in the photos of P.C. Board are being eliminated.
6. The shape of the parts and parts name, etc. can be confirmed by comparing them with the parts shown on the Electrical Parts Table of P.C. Board.
7. Both the kind of part and installation position can be determined by the Parts Number. To determine where a parts number is listed, utilize Parts Index at end of Parts List.  
It is necessary first of all to find the Parts Number. This can be accomplished by using the Reference Number listed at right of parts number in the Parts Index. (meaning of ref. no. outlined in Item 3 above).
8. Utilize separate "Price List for Parts" to determine unit price. The most simple method of finding parts Price is to utilize the reference number.

### CAUTION:

1. When placing an order for parts, be sure to list the parts no. model no., and description. There are instances in which if any of this information is omitted, parts cannot be shipped or the wrong parts will be delivered.
2. Please be careful not to make a mistake in the parts no. If the parts no. is in error, a part different from the one ordered may be delivered.
3. Because parts number and parts unit supply in the Preliminary Service Manual (Basic Parts List) may be partially changed, please use this parts list for all future reference.

**WARNING:** △ INDICATES SAFETY CRITICAL COMPONENTS. FOR CONTINUED SAFETY, REPLACE SAFETY CRITICAL COMPONENTS ONLY WITH MANUFACTURER'S RECOMEMNDED PARTS.

**AVERTISSEMENT:** △ IL INDIQU LES COMPOSANTS CRITIQUES DE SURETE. POUR MAINTENIR LE DEGRE DE SECURITE DE L'APPAREIL NE REMPLACER LES COMPOSANTS DONT LE FONCTIONNEMENT EST CRITIQUE POUR LA SECURITE QUE PAR DES PIECES RECOMMANDEES PAR LE FABRICANT.

## AC INLET SYSTEM

This model is equipped with an AC INLET SYSTEM. Please refer to the AC INLET SYSTEM CHART below for the specific type. By the AC INLET SYSTEM, AC (mains) cord can be connected to and disconnected from the model because the model is provided with socket exclusively for AC (mains) cord on its main body. Please note, however, that certain models are not equipped with this system and has a built-in AC (mains) cord as before.

### AC INLET SYSTEM CHART

#### CLASS I

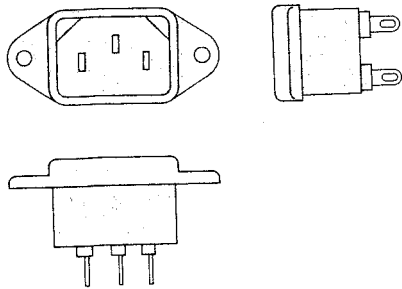

Picture 1  
AC INLET  
to be  
installed  
on machines

#### CLASS II

☐ This mark indicating double insulation will be attached to machine's rear panel

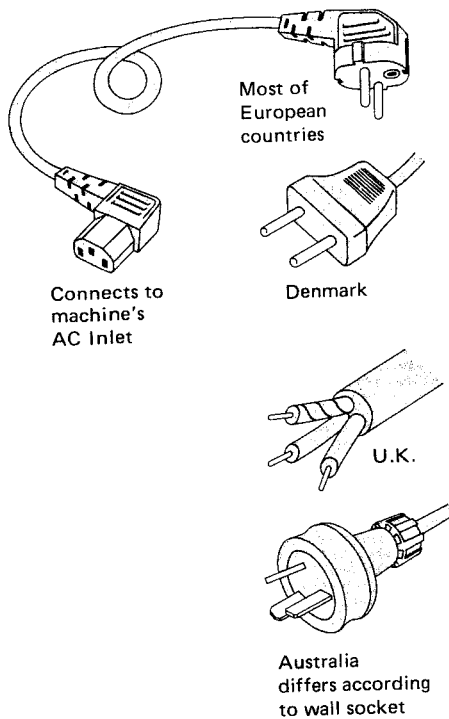
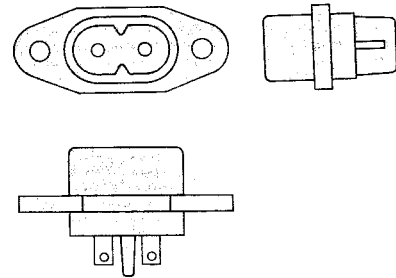

Picture 2  
AC (mains)  
cord

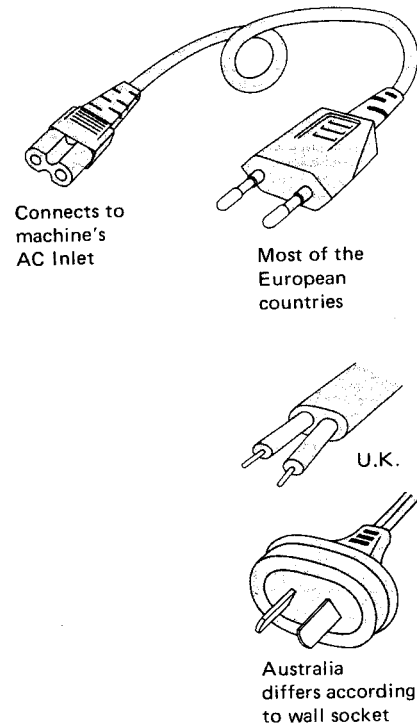

#### Parts List for AC (mains) Cord Set

Standard		Description	Type of AC Inlet	Parts No.
Class I	CEE	Cord Set CEE (3 cores)	3P	EW302993
	BEAB	Cord Set BEAB (3 cores)	3P	EW302994
	SAA	Cord Set SAA (3 cores)	3P	EW302996
	U/T	Cord Set U/T (3 cores)	3P	EW302646
Class II	CEE	Cord Set CEE (2 cores)	2P	EW638144
	BEAB	Cord Set BEAB (2 cores)	2P	EW302995
	SAA	Cord Set SAA (2 cores)	2P	EW302991
	U/T	Cord Set U/T (2 cores)	2P	EW302899

# I. MODEL AP-D30/C

## 1. DD SERVO P.C BOARD (APD-3051) BLOCK

Symbol No.	Parts No.	Description	Schematic No.
1-1	BA32072 5	DD Servo PCB Comp. AP-D30(U/T) (U/T)	APD-3077
1-2	BA32072 6	DD Servo PCB Comp. AP-D30(CSA)(CSA,AAL)	APD-3077
1-3	BA32072 7	DD Servo PCB Comp. AP-D30(CEE) (CEE, UK, SAA)	APD-3077
1-IC1,2	EI322599	IC TA75458S	45-8-415
1-TR1to4	ET30670 5	Transistor 2SC1815(O)(Y)	45-1-299
1-TR5	ET32550 1	Transistor 2SA1015(O)(Y)	45-1-328
1-TR6	ET32548 2	Transistor 2SC1959(Y)	45-1-385
1-TR7	ET30670 5	Transistor 2SC1815(O)(Y)	45-1-299
1-TR8	ET32550 1	Transistor 2SA1015(O)(Y)	45-1-328
1-TR10	ET30670 5	Transistor 2SC1815(O)(Y)	45-1-299
1-TR11	ET30671 9	Transistor 2SC2236(O)(Y)	45-1-307
1-TR12	ET30672 0	Transistor 2SA966(O)(Y)	45-1-306
1-TR13	ET30671 9	Transistor 2SC2236(O)(Y)	45-1-307
1-TR14	ET30672 0	Transistor 2SA966(O)(Y)	45-1-306
1-TR15,16	ET31924 0	Transistor 2SC1815(O)	45-1-299
1-TR17	ET30522 1	Transistor 2SC1815 (O)(Y)(GR)	45-1-299
1-D1	ED32111 5	Silicon Diode 1S1588	45-3-62
1-D2	ED32277 4	Zener Diode 05Z5.1U	45-6-76
1-D3to6	ED30672 4	Silicon Diode S5277B	45-2-79
1-D7	ED32111 5	Silicon Diode 1S1588	45-3-62
1-F3,4	EF30612 4	△ Fuse 630mA 250V (U/T)	39-1-64
1-F3,4	EF30570 3	△ Fuse 630mA 125V (CSA, AAL)	39-1-65
1-F3,4	EF66847 4	△ Fuse (SEMKO T) 400MAT (CEE, UK, SAA)	39-1-53
1-VR1,2	EV49936 4	Semi-fixed/Vol. V10K8-4-2 5KB	36-10-250
1-VR3,4	EV56013 6	Semi-fixed/Vol. V10K8-4-2 20KB	36-10-250
1-VR5	EV49988 2	Semi-fixed/Vol. V10K8-4-2 300KB	36-10-250
1-VR6	EV32558 8	Semi-fixed/Vol. (Metal Film) TM10K(PV) B200K	36-28-1
1-R25	ER30884 9	Carbon/R. F 1/4W 220 ohms (J)	35-11-25
1-R37	ER30425 6	Metal Oxide Film/R. 2W 56 ohm (J)	35-15-8
1-R38	ER30884 9	Carbon/R. F 1/4W 220 ohms (J)	35-11-25
1-C5	EC31765 0	Solid Aluminum/C. 0.4μF(K) 16WV	24-19-3
1-C6,7	EC32549 7	Solid Aluminum/C. 3.3μF(K) 16WV	24-19-3

## 2. RETURN SENSOR P.C BOARD (APD-3055) BLOCK

Symbol No.	Parts No.	Description	Schematic No.
2-D1	ED32111 5	Silicon Diode 1S1588	45-3-62
2-D2	ED56091 3	Silicon Diode 1S2473 VE	45-3-23
2-PH1	EI32552 9	Photo Interrupter EE-SH3-B	45-18-6

---

### 3. FUSE P.C BOARD (APD-3052/3062/3063)

#### BLOCK

Symbol No.	Parts No.	Description	Schematic No.
3-F1,2	EF309389	△ Fuse 400mA 250V (U/T)	39-1-64
3-F1	EF305703	△ Fuse 630mA 125V (CSA, AAL)	39-1-65
3-F1	EF593706	△ Fuse (SEMKO T) 500MAT (CEE, UK, SAA)	39-1-53
3-R2	ER314983	△ Metal Oxide Film/R. (Stop., W15) 1W 10K(J)	35-11-21
3-C1	EC302898	△ Metal Polyester/C. 0.047μF(K) 630WV (U/T)	24-9-120
3-C1	EC314688	△ Ceramic/C. DE7150 FZ 0.01μF(P)125WV(CSA, AAL)	24-5-87
3-C1	EC325485	△ MP/C. (Vert.) 0.047μF(M) 250WV (CEE, UK, SAA)	24-9-134



#### 4. ASSEMBLY BLOCK (1)

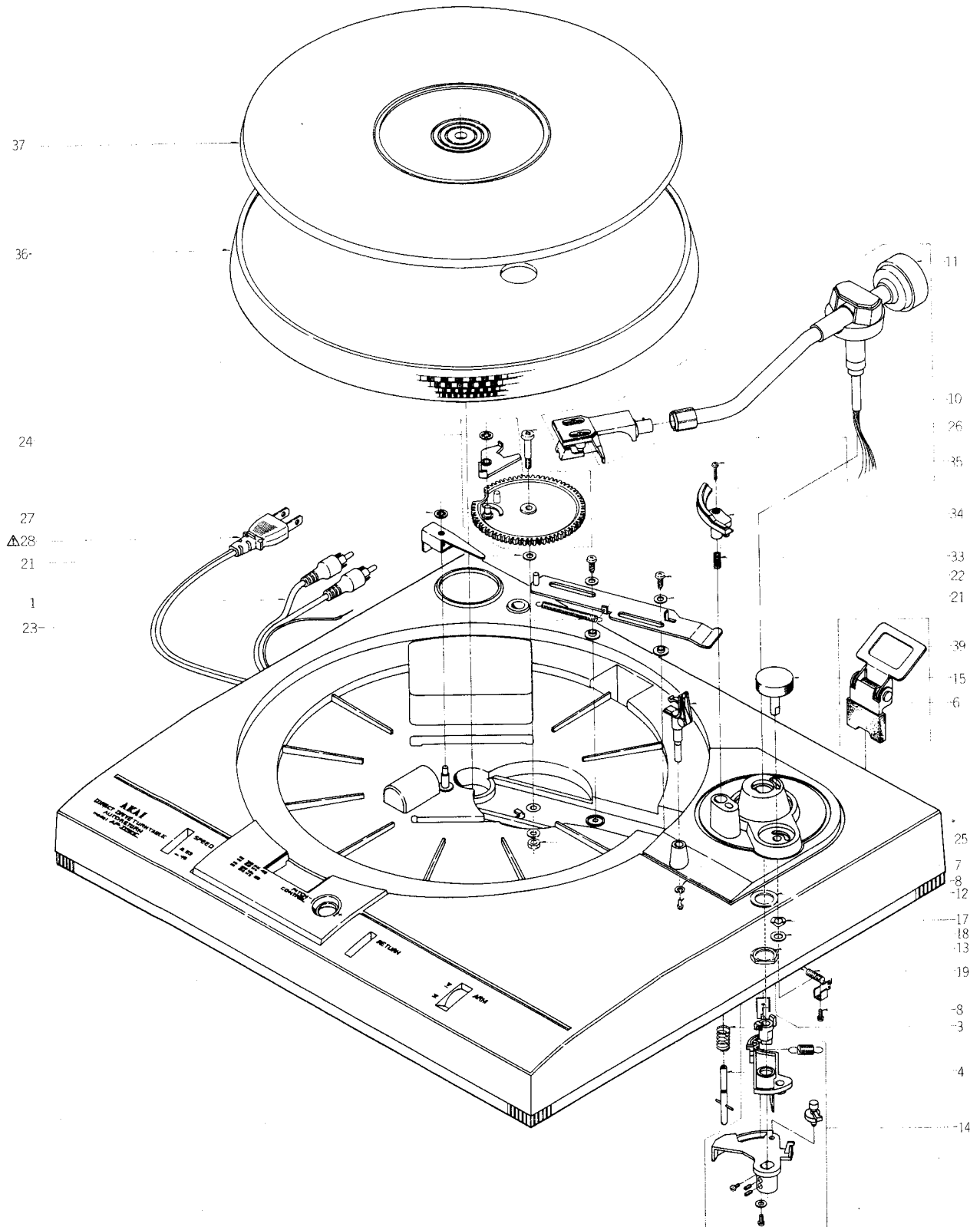

## ASSEMBLY BLOCK (1)

Ref. No.	Parts No.	Description	Schematic No.
<b>RELAY P.C BOARD BLOCK</b>			
4-1	EW325490	Pin Plug Cord 2P	26-10-20
4-2x	EW325489	Pin Plug Cord 2P(U/L)(AAL)	26-10-19
<b>ASSEMBLY BLOCK</b>			
4-3	ZG325402	Elevation Spring	APD-3010
4-4	TP325403	Elevation Shaft Part	APD-3011
4-5x	ZS325503	Special Tapping Screw, pan 3x12	7-1-70
4-6	TP320742	Arm Rest Part AP-D30	APD-3006
4-7	ZW300888	Washer D2.3x6x0.4t	
4-8	ZS669104	Tapping Screw, #2 pan 2.3x6	
4-9x	ZS321537	Special Tapping Screw, pan 3x10	7-1-70
4-10	TP320747	Tone Arm Part ARM-30	53-1-185
4-11	TP325499	Main Weight	53-1-185
4-12	ZW325517	Washer D13x20x0.5t	
4-13	ZW325521	Nut, M12 D12x17x3t P=1	
4-14	TP320718	PU Plate Assy AP-D30	APD-3073
4-15	SK320740	Canceler Knob Part AP-D30	APD-3050
4-16x	SK320741	Canceler Knob Part AP-D30-BL	APD-3050
4-17	ZW315478	Wave Washer (SUS) D5	
4-18	ZW313593	Washer (PBP) D5.1x10.3x0.5t	
4-19	ZG302825	Coil Spring (4)	AP-0021
4-20x	ZG321734	Canceller Spring (AAL)	AP-9047
4-21	ZW550642	Washer (SPC) D3.1x8x0.5t	
4-22	ZS321537	Special Tapping Screw, pan 3x10	7-1-70
4-23	ZG313008	Coil Spring T1-4.0/0.4-50.0	
4-24	TP320719	Main Gear Assy AP-D30	APD-3074
4-25	ZW273835	Nut M3, #1	
4-26	ZG325429	Shaft Screw	APD-3032
4-27	ZW653163	Retaining Ring CS Type 3	6-1-14
4-28	EW306428	△ AC Cord (U/T)(U/T)	26-3-64
4-29x	EW305691	△ AC Cord CUL (CSA, AAL)	26-3-65
4-30x	EW313882	△ AC Cord EC (CEE)	26-3-66
4-31x	EW313884	△ AC Cord BASEC. (UK)	26-3-67
4-32x	EW313883	△ AC Cord SAA (SAA)	26-3-69
4-33	ZG325470	Elevation Hight Adjust Spring	APD-3064
4-34	TP320743	Elevation Arm Part AP-D30	APD-3008
4-35	ZS325520	Screw, pan 2.6x12 (Black)	
4-36	TP325522	Platter	1-34-5
4-37	TP325443	Table Sheet	APD-3046
4-38x	TP323593	Table Sheet (B) (AAL)	APD-3046
4-39	TP320745	Hinge (D) Part AP-D30	9-4-9

# 5. ASSEMBLY BLOCK (2)

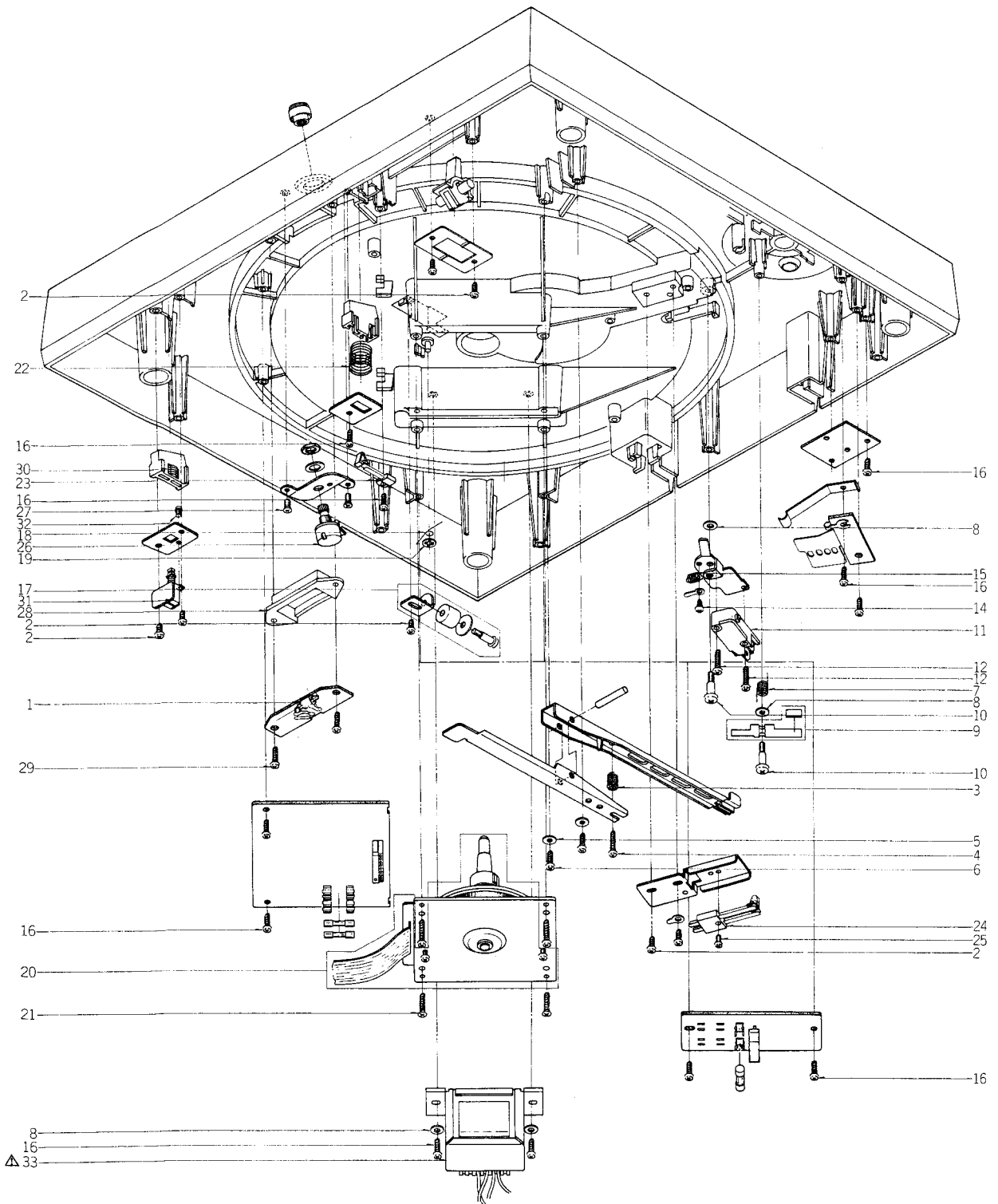

## ASSEMBLY BLOCK (2)

Ref. No.	Parts No.	Description	Schematic No.
<b>NEON LAMP P.C BOARD BLOCK</b>			
5-1	EL306690	Neon Lamp NE-2HH	28-3-9
<b>ASSEMBLY BLOCK</b>			
5-2	ZS322402	Special Tapping Screw, pan 3x8	7-1-70
5-3	ZG313209	Coil Spring C-5.5/0.8-12.5	
5-4	ZS422965	Screw, pan 3x15	
5-5	ZW550642	Washer (SPC) D3.1x8x0.5t	
5-6	ZS321537	Special Tapping Screw, pan 3x10	7-1-70
5-7	ZG325435	Brake Lever Spring	APD-3038
5-8	ZW616004	Washer D3.1x8x1t	
5-9	TP320748	Brake Lever Assy AP-D30	APD-3087
5-10	ZS325426	Tapping Roller Screw	APD-3029
5-11	ES325488	Micro SW. K-1	25-1-63
5-12	ZS422965	Screw, pan 3x15 (U/T, CSA, AAL)	
5-13x	ZS302778	Screw, pan 3x15 (PC) (CEE, UK, SAA)	 Bei Schalterwechsel aus Sicherheitsgründen nur Schrauben des gleichen Materials verwenden!
5-14	ZS325495	Tapping Screw, #2 BR 3x6	
5-15	ZG313071	Coil Spring T1-6.3/0.5-22.4	
5-16	ZS321537	Special Tapping Screw, pan 3x10	7-1-70
5-17	EP320723	Plunger Assy AP-D30	44-1-130
5-18	ZG325444	Reject Spring	APD-3047
5-19	ZW653163	Retaining Ring CS Type 3	6-1-14
5-20	BM320724	Motor BLK DDM-6C	9-2-43
5-21	ZS325523	B-Tight Screw, Countersunk 3x16	7-1-77
5-22	ZG316400	Return Spring	AP-1105
5-23	ES325483	Leaf SW. MSW-0061BU	25-10-42
5-24	ES325484	Leaf SW. MSW-0014	25-10-44
5-25	ZS304767	Screw, pan 2x6	
5-26	EV325494	Vol. VM10RD60A 1kB	36-6-44
5-27	ZS325525	B-Tight Screw, Countersunk 3x10	7-1-77
5-28	SZ325419	Lamp House (A)	APD-3023
5-29	ZS325503	Special Tapping Screw, pan 3x12	7-1-70
5-30	ZG325446	Button Spring	APD-3049
5-31	ES325493	Push SW. SPJ222L	25-5-362
5-32	ZS432843	Screw, pan 2.6x4	
5-33	BT325486	⚠ Power Trans. APT30-40 (U/T, CEE, UK, SAA)	38-4-794
5-34x	BT325487	⚠ Power Trans. APT30-30 (CSA, AAL)	38-4-795

## 6. ASSEMBLY BLOCK (3)



### ASSEMBLY BLOCK (3)

Ref. No.	Parts No.	Description	Schematic No.
6-1	SK325407	Elevation Knob	APD-3015
6-2x	SK325408	Elevation Knob (BL)	APD-3015
6-3	SB325410	Return Button	APD-3017
6-4x	SB325411	Return Button (BL)	APD-3017
6-5	SB325416	Speed Change Button	APD-3021
6-6x	SB325417	Speed Change Button (BL)	APD-3021
6-7	SK325414	Control Knob	APD-3020
6-8x	SK325415	Control Knob (BL)	APD-3020
6-9x	TP302504	Rubber Bush	AP-0043
6-10x	ZS421740	Screw, pan 3x8 (Black) (AAL)	
6-11x	ZW273756	Nut, #1 M3 (AAL)	
6-12x	SP325680	Rear Plate (B)	APD-3042
6-13x	SA320746	Insulator Part AP-D30	APD-3043
6-14x	ZS325524	P-Tight Screw, BR 3x12 W/Flange	7-1-78
6-15	BC320744	Dust Cover Part AP-D30	2-34-194
6-16	SM325445	Name Plate	APD-3048

When ordering parts, please quote Parts Number, Description and Model Number.

## II. MODEL AP-Q50/C

### 1. QUARTZ SERVO P.C BOARD (APQ-5009) BLOCK

Symbol No.	Parts No.	Description	Schematic No.
1-1	BA32 0836	Quartz Servo PCB Comp. AP-Q50(U/T) (U/T, CSA)	APQ-5019
1-2	BA32 0837	Quartz Servo PCB Comp. AP-Q50(AAL)(AAL)	APQ-5019
1-3	BA32 0846	Quartz Servo PCB Comp. AP-Q50(CEE) (CEE, UK, SAA)	APQ-5019
1-IC1	EI633982	IC SN7400N	45-8-142
1-IC2	EI325557	IC AP-400-A	45-8-435
1-IC3,4	EI322599	IC TA75458S	45-8-415
1-TR1,2	ET30 7234	Transistor 2SC1815 (Y)(GR)	45-1-299
1-TR3	ET32 5482	Transistor 2SC1959(Y)	45-1-385
1-TR4	ET30 7234	Transistor 2SC1815 (Y)(GR)	45-1-299
1-TR5,6	ET32 5501	Transistor 2SA1015(O)(Y)	45-1-328
1-TR7	ET30 6719	Transistor 2SC2236(O)(Y)	45-1-307
1-TR8	ET30 6720	Transistor 2SA966(O)(Y)	45-1-306
1-TR9	ET30 6719	Transistor 2SC2236(O)(Y)	45-1-307
1-TR10	ET30 6720	Transistor 2SA966(O)(Y)	45-1-306
1-TR11,12	ET32 5502	Transistor 2SC790(Y)	45-1-304
1-TR13	ET30 6720	Transistor 2SA966(O)(Y)	45-1-306
1-TR14	ET31 0168	Transistor 2SC2229(O)(Y)	45-1-305
1-TR15,16	ET31 9241	Transistor 2SC1815(Y)	45-1-299
1-D1	ED32 1115	Silicon Diode 1S1588	45-3-62
1-D2	ED30 3155	Zener Diode 05Z-5.6U	45-6-76
1-D3,4	ED32 3353	Zener Diode 05Z-12L	45-6-76
1-D5to8	ED30 6724	Silicon Diode S5277B	45-2-79
1-D9,10	ED30 6732	Silicon Diode S5277D	45-2-80
1-D11,12	ED56 0913	Silicon Diode 1S2473 VE	45-3-23
1-VR1	EV63 8548	Semi-fixed/Vol. (Metallized Film) TM10K(PV) B20K	36-28-1
1-VR2	EV59 3368	Semi-fixed/Vol. V10K8-4-2 B30K	36-10-250
1-VR3,4	EV56 0136	Semi-fixed/Vol. V10K8-4-2 20KB	36-10-250
1-VR5	EV64 8527	Semi-fixed/Vol. V10K8-4-2 B200K	36-10-250
1-VR6	EV32 5588	Semi-fixed/Vol. (Metal Film) TM10K(PV) B200K	36-28-1
1-X1	EE32 5558	X'tal OSC 5.4MHz	53-1-186
1-L1	EO53 9820	Peaking Coil 2.2μH(K)	23-1-187
1-VC1	EC61 6342	Trimmer/C. CTY122D33 15PF	24-2-32
1-F3	EF30 8933	△ Fuse 200mA 250V (U/T, CSA)	39-1-64
1-F3	EF30 0574	△ Fuse (EAWK) 125MAT (CEE, UK, SAA)	39-1-60
1-F4,5	EF30 9389	△ Fuse 400mA 250V (U/T, CSA)	39-1-64
1-F4,5	EF30 8848	△ Fuse 400mA 125V (AAL)	39-1-65
1-F4,5	EF69 5766	△ Fuse (SEMKO T) 315MAT (CEE, UK, SAA)	39-1-53
1-C15,16	EC32 5559	Solid Aluminum/C. 1.5μF(K) 25WV	24-19-3

### 2. RETURN SENSOR P.C BOARD BLOCK

Symbol No.	Parts No.	Description	Schematic No.
2-D1	ED321115	Silicon Diode 1S1588	45-3-62
2-D2	ED560913	Silicon Diode 1S2473 VE	45-3-23
2-PH1	EI325529	Photo Interrupter EE-SH3-B	45-18-6

### 3. FUSE P.C BOARD (APD-3052/APQ-5014/5016/5017) BLOCK

Symbol No.	Parts No.	Description	Schematic No.
3-TR1	ET310168	Transistor 2SC2229(O)(Y) (AAL)	45-1-305
3-D1,2	ED306732	Silicon Diode S5277D (AAL)	45-2-80
3-F1,2	EF309389	△ Fuse 400mA 250V (U/T)	39-1-64
3-F1	EF309389	△ Fuse 400mA 250V (CSA)	39-1-64
3-F1	EF308848	△ Fuse 400mA 125V (AAL)	39-1-65
3-F1	EF695766	△ Fuse (SEMKO T) 315MAT (CEE, UK, SAA)	39-1-53
3-F2	EF315334	△ Fuse 250mA 125V (AAL)	39-1-65
3-C1	EC302898	△ Metal Polyester/C. 0.047μF(K) 630WV (U/T)	24-9-120
3-C1	EC314688	△ Ceramic/C. DE7150 FZ 0.01μF(P)125WV(CSA, AAL)	24-5-87
3-C1	EC325485	△ MP/C. (Vert.) 0.047μF(M) 250WV (CEE, UK, SAA)	24-9-134

#### 4. ASSEMBLY BLOCK (1)

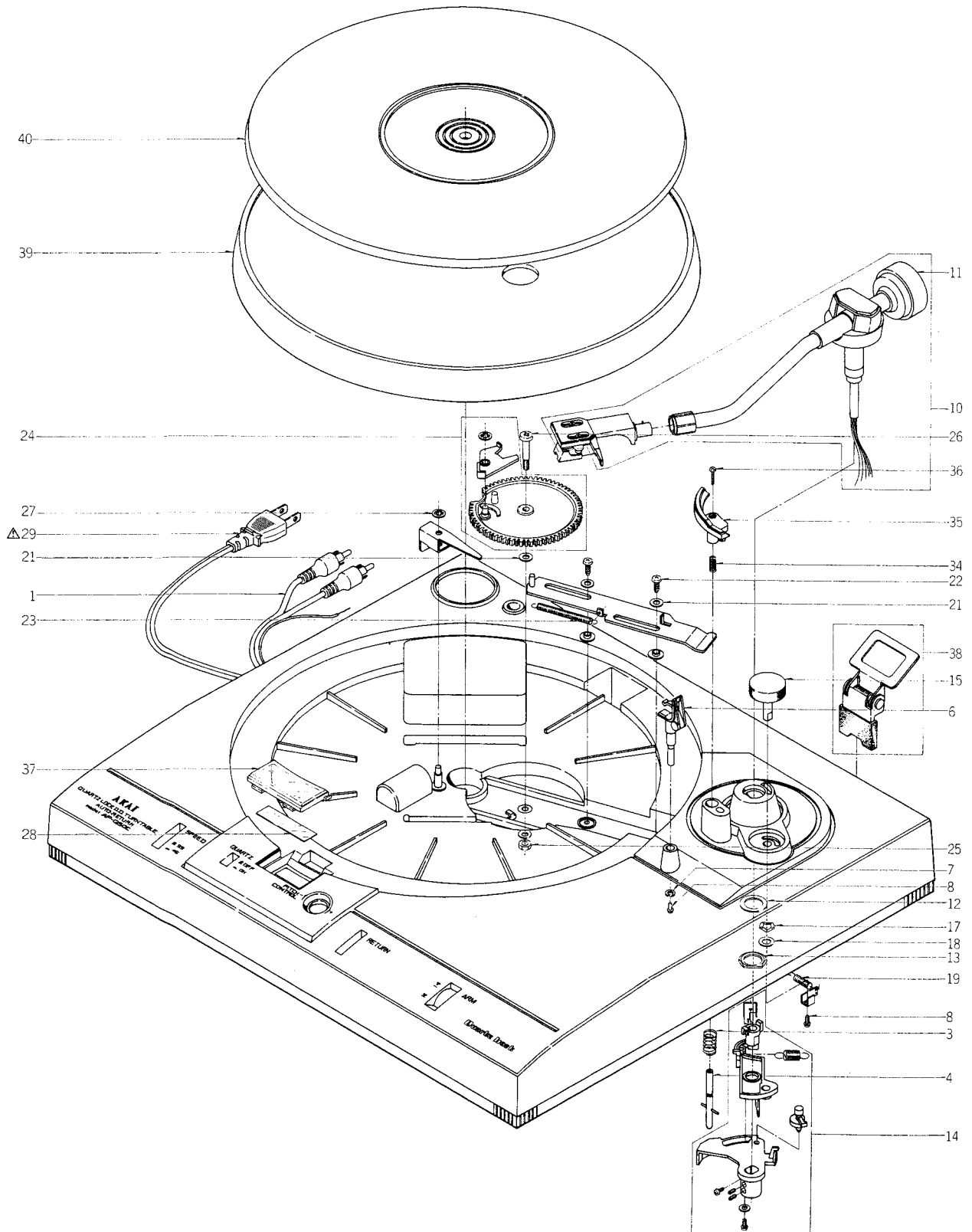

## ASSEMBLY BLOCK (1)

Ref. No.	Parts No.	Description	Schematic No.
<b>RELAY P.C BOARD BLOCK</b>			
4-1	EW325490	Pin Plug Cord 2P	26-10-20
4-2x	EW325489	Pin Plug Cord 2P(U/L)(AAL)	26-10-19
<b>ASSEMBLY BLOCK</b>			
4-3	ZG325402	Elevation Spring	APD-3010
4-4	TP325403	Elevation Shaft Part	APD-3011
4-5x	ZS325503	Special Tapping Screw, pan 3x12	7-1-70
4-6	TP320742	Arm Rest Part AP-D30	APD-3006
4-7	ZW300888	Washer D2.3x6x0.4t	
4-8	ZS669104	Tapping Screw, #2 pan 2.3x6	
4-9x	ZS321537	Special Tapping Screw, pan 3x10	7-1-70
4-10	TP320747	Tone Arm Part ARM-30	53-1-185
4-11	TP325499	Main Weight	53-1-185
4-12	ZW325517	Washer D13x20x0.5t	
4-13	ZW325521	Nut, M12 D12x17x3t P=1	
4-14	TP320718	PU Plate Assy AP-D30	APD-3073
4-15	SK320740	Canceler Knob Part AP-D30	APD-3050
4-16x	SK320741	Canceler Knob Part AP-D30-BL	APD-3050
4-17	ZW315478	Wave Washer (SUS) D5	
4-18	ZW313593	Washer (PBP) D5.1x10.3x0.5t	
4-19	ZG302825	Coil Spring (4)	AP-0021
4-20x	ZG321734	Canceller Spring (AAL)	AP-9047
4-21	ZW550642	Washer (SPC) D3.1x8x0.5t	
4-22	ZS321537	Special Tapping Screw, pan 3x10	7-1-70
4-23	ZG313008	Coil Spring T1-4.0/0.4-50.0	
4-24	TP320719	Main Gear Assy AP-D30	APD-3074
4-25	ZW273835	Nut M3, #1	
4-26	ZG325429	Shaft Screw	APD-3032
4-27	ZW653163	Retaining Ring CS Type 3	6-1-14
4-28	TP325539	Strobe Mirror	APQ-5007
4-29	EW374894	△ AC Cord U/T (U/T)	26-3-19
4-30x	EW207742	△ AC Cord CUL (CSA, AAL)	26-3-45
4-31x	EW604618	△ AC Cord (EC) VM-0064 (CEE)	26-3-34
4-32x	EW232244	△ AC Cord BASEC 2 Core (UK)	26-3-46
4-33x	EW284084	△ AC Cord (SAA)	26-3-52
4-34	ZG325470	Elevation Hight Adjust Spring	APD-3064
4-35	TP320743	Elevation Arm Part AP-D30	APD-3008
4-36	ZS325520	Screw, pan 2.6x12 (Black)	
4-37	SZ325536	Lamp House (A)	APQ-5004
4-38	TP320745	Hinge (D) Part AP-D30	9-4-9
4-39	TP325551	Platter	1-34-6
4-40	TP325443	Table Sheet	APD-3046
4-41x	TP323593	Table Sheet (B) (AAL)	APD-3046



# 5. ASSEMBLY BLOCK (2)

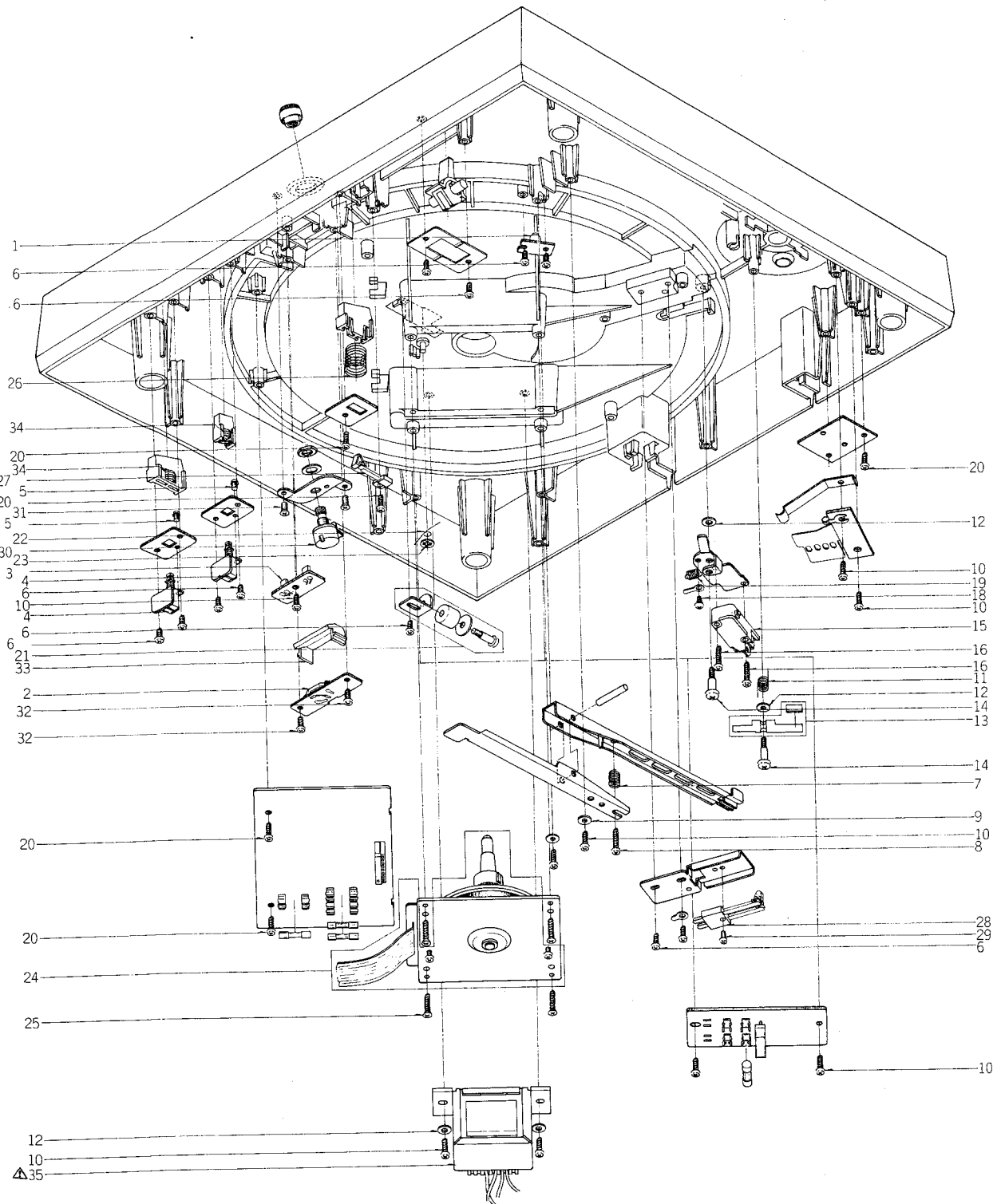

## ASSEMBLY BLOCK (2)

Ref. No.	Parts No.	Description	Schematic No.
<b>FG SENSOR P.C BOARD BLOCK</b>			
5-1	EI325556	Photo Sensor NJL5141E-A	45-18-3
<b>NEON LAMP P.C BOARD BLOCK</b>			
5-2	EL325554	Neon Lamp. NE-2HH-D6	28-3-10
<b>LED P.C BOARD BLOCK</b>			
5-3	ED310584	LED GL-9PR2	45-15-21
<b>PUSH SW. P.C BOARD BLOCK</b>			
5-4	ES325493	Push SW. SPJ222L	25-5-362
5-5	ZS432843	Screw, pan 2.6x4	
<b>ASSEMBLY BLOCK</b>			
5-6	ZS322402	Special Tapping Screw, pan 3x8	7-1-70
5-7	ZG313209	Coil Spring C-5.5/0.8-12.5	
5-8	ZS422965	Screw, pan 3x15	
5-9	ZW550642	Washer (SPC) D3.1x8x0.5t	
5-10	ZS321537	Special Tapping Screw, pan 3x10	7-1-70
5-11	ZG325435	Brake Lever Spring	APD-3038
5-12	ZW616004	Washer D3.1x8x1t	
5-13	TP320748	Brake Lever Assy AP-D30	APD-3087
5-14	ZS325426	Tapping Roller Screw	APD-3029
5-15	ES325488	Micro SW. K-1	25-1-63
5-16	ZS422965	Screw, pan 3x15 (U/T, CSA, AAL)	
5-17x	ZS302778	Screw, pan 3x15 (PC) (CEE, UK, SAA)	
5-18	ZS325495	Tapping Screw, #2 BR 3x6	
5-19	ZG313071	Coil Spring T1-6.3/0.5-22.4	
5-20	ZS321537	Special Tapping Screw, pan 3x10	7-1-70
5-21	EP320723	Plunger Assy AP-D30	44-1-130
5-22	ZG325444	Reject Spring	APD-3047
5-23	ZW653163	Retaining Ring CS Type 3	6-1-14
5-24	BM320724	Motor BLK DDM-6C	9-2-43
5-25	ZS325523	B-Tight Screw, Countersunk 3x16	7-1-77
5-26	ZG316400	Return Spring	AP-1105
5-27	ES325483	Leaf SW. MSW-0061BU	25-10-42
5-28	ES325484	Leaf SW. MSW-0014	25-10-44
5-29	ZS304767	Screw, pan 2x6	
5-30	EV325555	Vol. VM10RD60A 5KB	36-6-45
5-31	ZS325525	B-Tight Screw, Countersunk 3x10	7-1-77
5-32	ZS325503	Special Tapping Screw, pan 3x12	7-1-70
5-33	SZ325537	Lamp House (B)	APQ-5005
5-34	ZG325446	Button Spring	APD-3049
5-35	BT325552	⚠ Power Trans. APT50-40 (U/T, CSA, UK, SAA)	38-4-796
5-36x	BT325553	⚠ Power Trans. APT50-30 (CSA, AAL)	38-4-797

⚠ Bei Schalterwechsel aus Sicherheitsgründen nur Schrauben des gleichen Materials verwenden!

## 6. ASSEMBLY BLOCK (3)

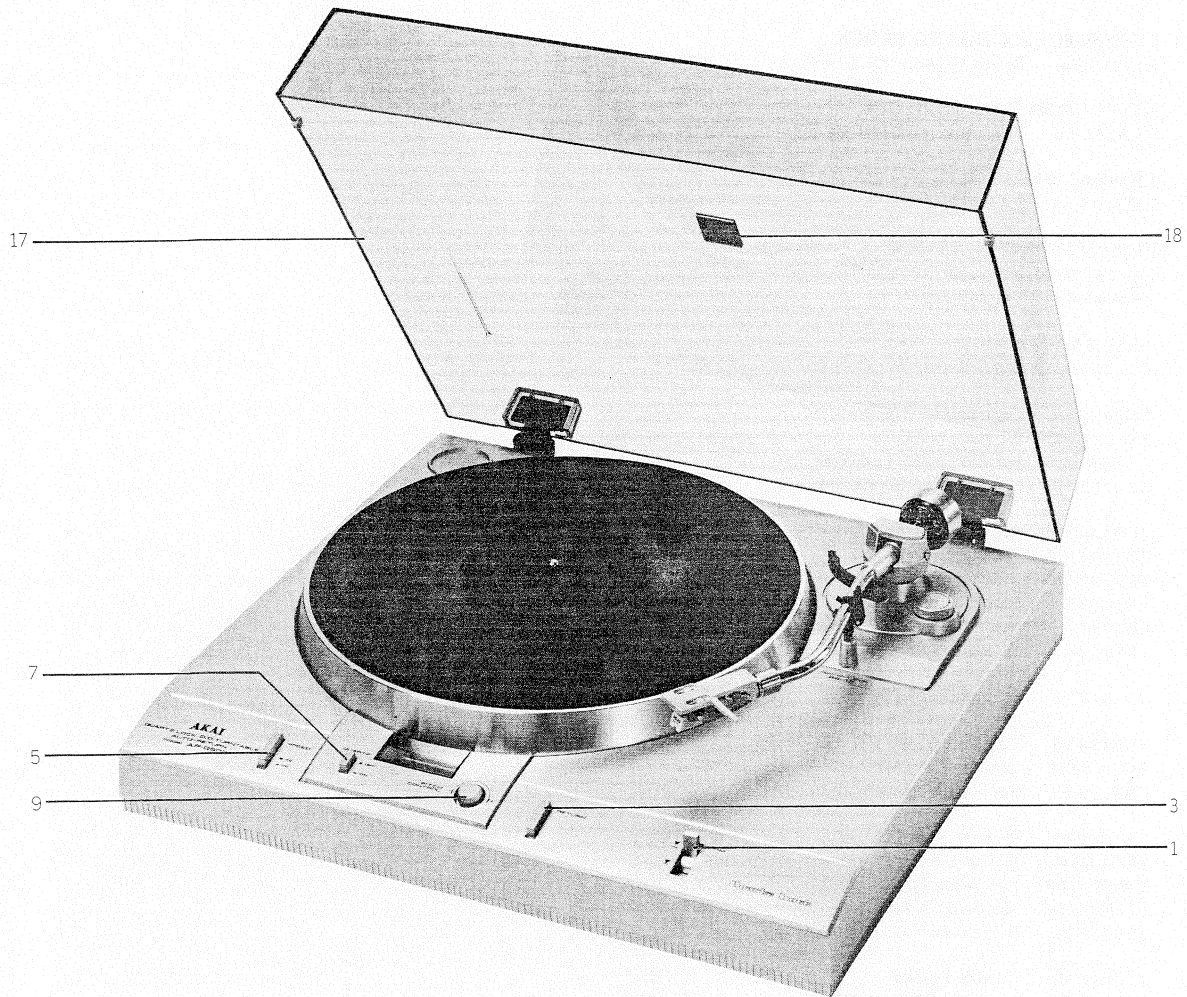

### ASSEMBLY BLOCK (3)

Ref. No.	Parts No.	Description	Schematic No.
6-1	SK325407	Elevation Knob	APD-3015
6-2x	SK325408	Elevation Knob (BL)	APD-3015
6-3	SB325410	Return Button	APD-3017
6-4x	SB325411	Return Button (BL)	APD-3017
6-5	SB325416	Speed Change Button	APD-3021
6-6x	SB325417	Speed Change Button (BL)	APD-3021
6-7	SB325534	Quartz Lock Button	APQ-5003
6-8x	SB325535	Quartz Lock Button (BL)	APQ-5003
6-9	SK325414	Control Knob	APD-3020
6-10x	SK325415	Control Knob (BL)	APD-3020
6-11x	TP302504	Rubber Bush	AP-0043
6-12x	ZS421740	Screw, pan 3x8 (Black) (AAL)	
6-13x	ZW273756	Nut, #1 M3 (AAL)	
6-14x	SP325680	Rear Plate (B)	APD-3042
6-15x	SA320746	Insulator Part AP-D30	APD-3043
6-16x	ZS325524	P-Tight Screw, BR 3x12 W/Flange	7-1-78
6-17	BC320744	Dust Cover Part AP-D30	2-34-194
6-18	SM325445	Name Plate	APD-3048

When ordering parts, please quote Parts Number, Description and Model Number.

# INDEX

## 1. MODEL AP-D30/C

Parts No.	Ref. No. & Symbol No.	Parts No.	Ref. No. & Symbol No.	Parts No.	Ref. No. & Symbol No.	Parts No.	Ref. No. & Symbol No.	Parts No.	Ref. No. & Symbol No.
BA320725	1-1	ER308849	1-R38	SA320746	6-13x	ZG313209	5-3	ZW273835	4-25
BA320726	1-2	ER314983	3-R2	SB325410	6-3	ZG316400	5-22	ZW300888	4-7
BA320727	1-3	ES325483	5-23	SB325411	6-4x	ZG321734	4-20x	ZW313593	4-18
BC320744	6-15	ES325484	5-24	SB325416	6-5	ZG325402	4-3	ZW315478	4-17
BM320724	5-20	ES325488	5-11	SB325417	6-6x	ZG325429	4-26	ZW325517	4-12
BT325486	5-33	ES325493	5-31	SK320740	4-15	ZG325435	5-7	ZW325521	4-13
BT325487	5-34x	ET305221	1-TR17	SK320741	4-16x	ZG325444	5-18	ZW550642	4-21
EC302898	3-C1	ET306705	1-TR1to4	SK325407	6-1	ZG325446	5-30	ZW550642	5-5
EC314688	3-C1	ET306705	1-TR7	SK325408	6-2x	ZG325470	4-33	ZW616004	5-8
EC317650	1-C5	ET306705	1-TR10	SK325414	6-7	ZS302778	5-13x	ZW653163	4-27
EC325485	3-C1	ET306719	1-TR11	SK325415	6-8x	ZS304767	5-25	ZW653163	5-19
EC325497	1-C6,7	ET306719	1-TR13	SM325445	6-16	ZS321537	4-9x		
ED306724	1-D3to6	ET306720	1-TR12	SP325680	6-12x	ZS321537	4-22		
ED321115	1-D1	ET306720	1-TR14	SZ325419	5-28	ZS321537	5-6		
ED321115	1-D7	ET319240	1-TR15,16	TP302504	6-9x	ZS321537	5-16		
ED321115	2-D1	ET325482	1-TR6	TP320718	4-14	ZS322402	5-2		
ED322774	1-D2	ET325501	1-TR5	TP320719	4-24	ZS325426	5-10		
ED560913	2-D2	ET325501	1-TR8	TP320742	4-6	ZS325495	5-14		
EF305703	1-F3,4	EV325494	5-26	TP320743	4-34	ZS325503	4-5x		
EF305703	3-F1	EV325588	1-VR6	TP320745	4-39	ZS325503	5-29		
EF306124	1-F3,4	EV499364	1-VR1,2	TP320747	4-10	ZS325520	4-35		
EF309389	3-F1,2	EV499882	1-VR5	TP320748	5-9	ZS325523	5-21		
EF593706	3-F1	EV560136	1-VR3,4	TP323593	4-38x	ZS325524	6-14x		
EF668474	1-F3,4	EW305691	4-29x	TP325403	4-4	ZS325525	5-27		
EI322599	1-IC1,2	EW306428	4-28	TP325443	4-37	ZS421740	6-10x		
EI325529	2-PH1	EW313882	4-30x	TP325499	4-11	ZS422965	5-4		
EL306690	5-1	EW313883	4-32x	TP325522	4-36	ZS422965	5-12		
EP320723	5-17	EW313884	4-31x	ZG302825	4-19	ZS432843	5-32		
ER304256	1-R37	EW325489	4-2x	ZG313008	4-23	ZS669104	4-8		
ER308849	1-R25	EW325490	4-1	ZG313071	5-15	ZW273756	6-11x		

## 2. MODEL AP-Q50/C

Parts No.	Ref. No. & Symbol No.	Parts No.	Ref. No. & Symbol No.	Parts No.	Ref. No. & Symbol No.	Parts No.	Ref. No. & Symbol No.	Parts No.	Ref. No. & Symbol No.
BA320836	1-1	EF315334	3-F2	EV560136	1-VR3,4	TP320719	4-24	ZS322402	5-6
BA320837	1-2	EF695766	1-F4,5	EV593368	1-VR2	TP320742	4-6	ZS325426	5-14
BA320846	1-3	EF695766	3-F1	EV638548	1-VR1	TP320743	4-35	ZS325495	5-18
BC320744	2-17	EI322599	1-IC3,4	EV648527	1-VR5	TP320745	4-38	ZS325503	4-5x
BM320724	5-24	EI325529	2-PH1	EW207742	4-30x	TP320747	4-10	ZS325503	5-32
BT325552	5-35	EI325556	5-1	EW232244	4-32x	TP320748	5-13	ZS325520	4-36
BT325553	5-36x	EI325557	1-IC2	EW284084	4-33x	TP323593	4-41x	ZS325523	5-25
EC302898	3-C1	EI633982	1-IC1	EW325489	4-2x	TP325403	4-4	ZS325524	6-16x
EC314688	3-C1	EL325554	5-2	EW325490	4-1	TP325443	4-40	ZS325525	5-31
EC325485	3-C1	EO539820	1-L1	EW374894	4-29	TP325499	4-11	ZS421740	6-12x
EC325559	1-C15,16	EP320723	5-21	EW604618	4-31x	TP325539	4-28	ZS422965	5-8
EC616342	1-VC1	ES325483	5-27	SA320746	6-15x	TP325551	4-39	ZS422965	5-16
ED303155	1-D2	ES325484	5-28	SB325410	6-3	ZG302825	4-19	ZS432843	5-5
ED306724	1-D5to8	ES325488	5-15	SB325411	6-4x	ZG313008	4-23	ZS669104	4-8
ED306732	1-D9,10	ES325493	5-4	SB325416	6-5	ZG313071	5-19	ZW273756	6-13x
ED306732	3-D1,2	ET306719	1-TR7	SB325417	6-6x	ZG313209	5-7	ZW273835	4-25
ED310584	5-3	ET306719	1-TR9	SB325534	6-7	ZG316400	5-26	ZW300888	4-7
ED321115	1-D1	ET306720	1-TR8	SB325535	6-8x	ZG321734	4-20x	ZW313593	4-18
ED321115	2-D1	ET306720	1-TR10	SK320740	4-15	ZG325402	4-3	ZW315478	4-17
ED323353	1-D3,4	ET306720	1-TR13	SK320741	4-16x	ZG325429	4-26	ZW325517	4-12
ED560913	1-D11,12	ET307234	1-TR1,2	SK325407	6-1	ZG325435	5-11	ZW325521	4-13
ED560913	2-D2	ET307234	1-TR4	SK325408	6-2x	ZG325444	5-22	ZW550642	4-21
EE325558	1-X1	ET310168	1-TR14	SK325414	6-9	ZG325446	5-34	ZW550642	5-9
EF300574	1-F3	ET310168	3-TR1	SK325415	6-10x	ZG325470	4-34	ZW616004	5-12
EF308848	1-F4,5	ET319241	1-TR15,16	SM325445	6-18	ZS302778	5-17x	ZW653163	4-27
EF308848	3-F1	ET325482	1-TR3	SP325680	6-14x	ZS304767	5-29	ZW653163	5-23
EF308933	1-F3	ET325501	1-TR5,6	SZ325536	4-37	ZS321537	4-9x		
EF309389	1-F4,5	ET325502	1-TR11,12	SZ325537	5-33	ZS321537	4-22		
EF309389	3-F1,2	EV325555	5-30	TP302504	6-11x	ZS321537	5-10		
EF309389	3-F1	EV325588	1-VR6	TP320718	4-14	ZS321537	5-20		

SECTION 3

# SCHEMATIC DIAGRAM

1. SCHEMATIC DIAGRAM OF ICs
2. AP-D30/C NO. 1600422A SCHEMATIC DIAGRAM
3. AP-Q50/C NO. 1600423A SCHEMATIC DIAGRAM

SN7400N

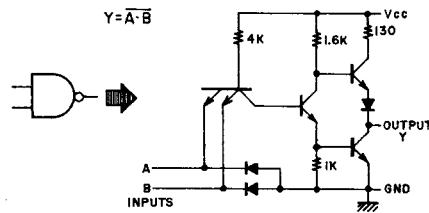
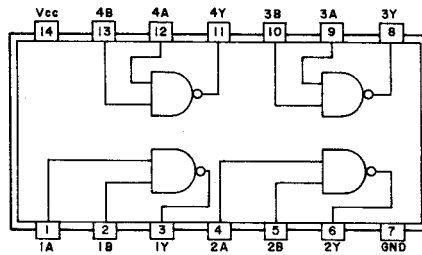

TA75458S

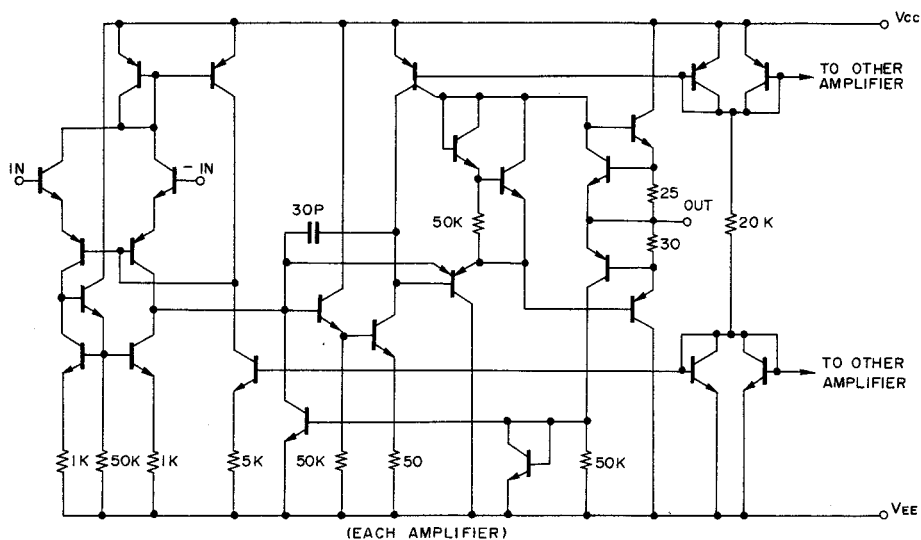
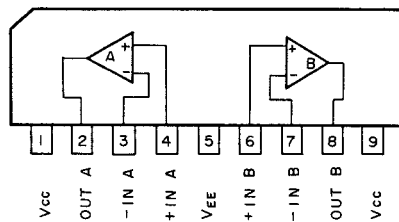

AP-D30/C

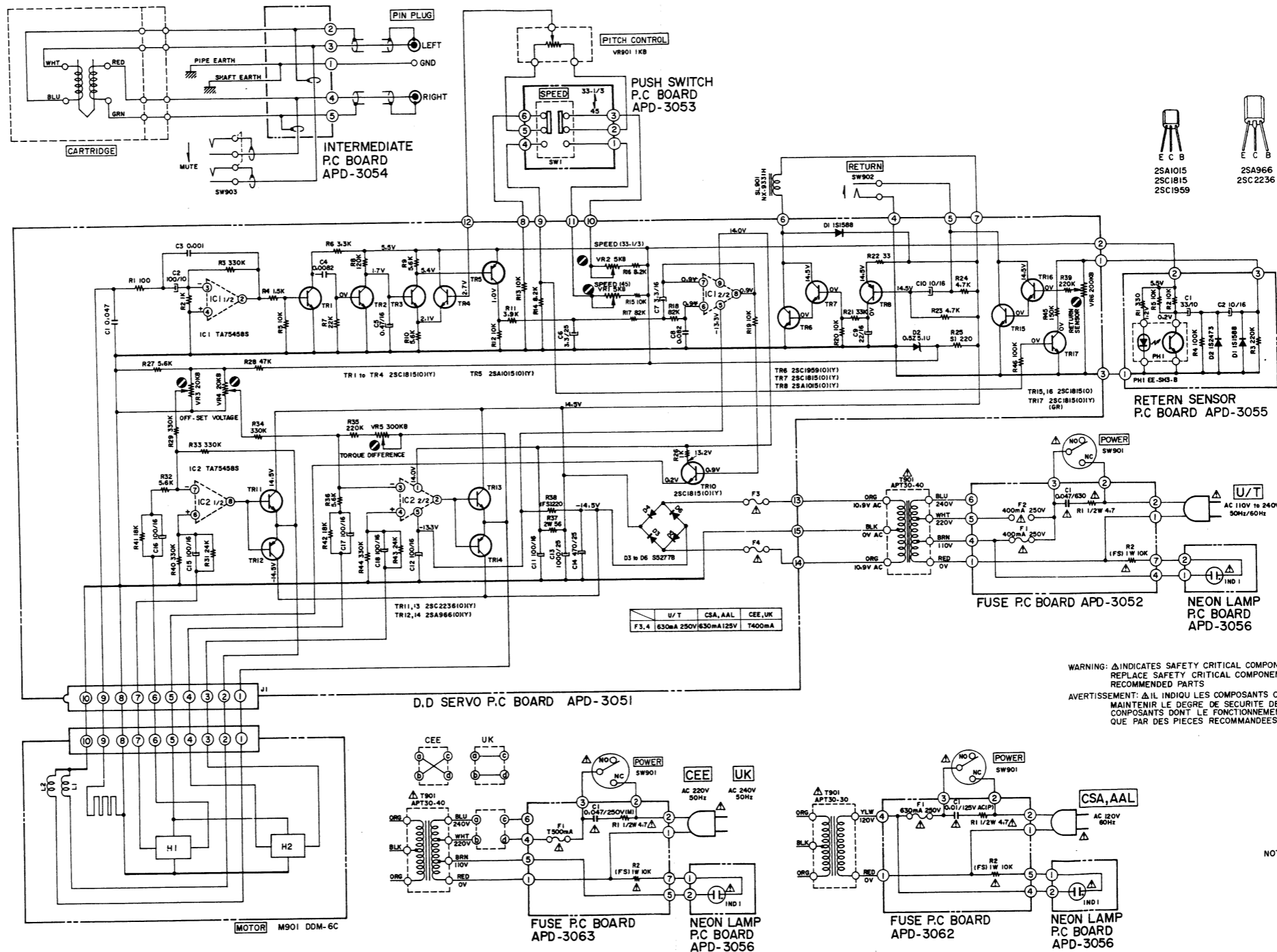

WARNING: Δ INDICATES SAFETY CRITICAL COMPONENTS. FOR CONTINUED SAFETY, REPLACE SAFETY CRITICAL COMPONENTS ONLY WITH MANUFACTURER'S RECOMMENDED PARTS.  
 AVERTISSEMENT: Δ IL INDIQUE LES COMPOSANTS CRITIQUES DE SÛRETÉ. POUR MAINTENIR LE DEGRÉ DE SÛRETÉ DE L'APPAREIL NE REMPLACER LES COMPOSANTS DONT LE FONCTIONNEMENT EST CRITIQUE POUR LA SÛRETÉ QUE PAR DES PIÈCES RECOMMANDÉES PAR LE FABRICANT.

NOTE  
 UNLESS OTHERWISE SPECIFIED  
 ALL RESISTORS IN OHMS 1/4W(J)  
 ALL CAPACITORS IN μF 50WV(J)  
 (FS) = FAIL SAFE RESISTOR  
 POWER TRANSFORMER IS DIFFERENT ACCORDING TO AREA.

AP-D30/C  
 SCHEMATIC DIAGRAM  
 NO. 1600422A

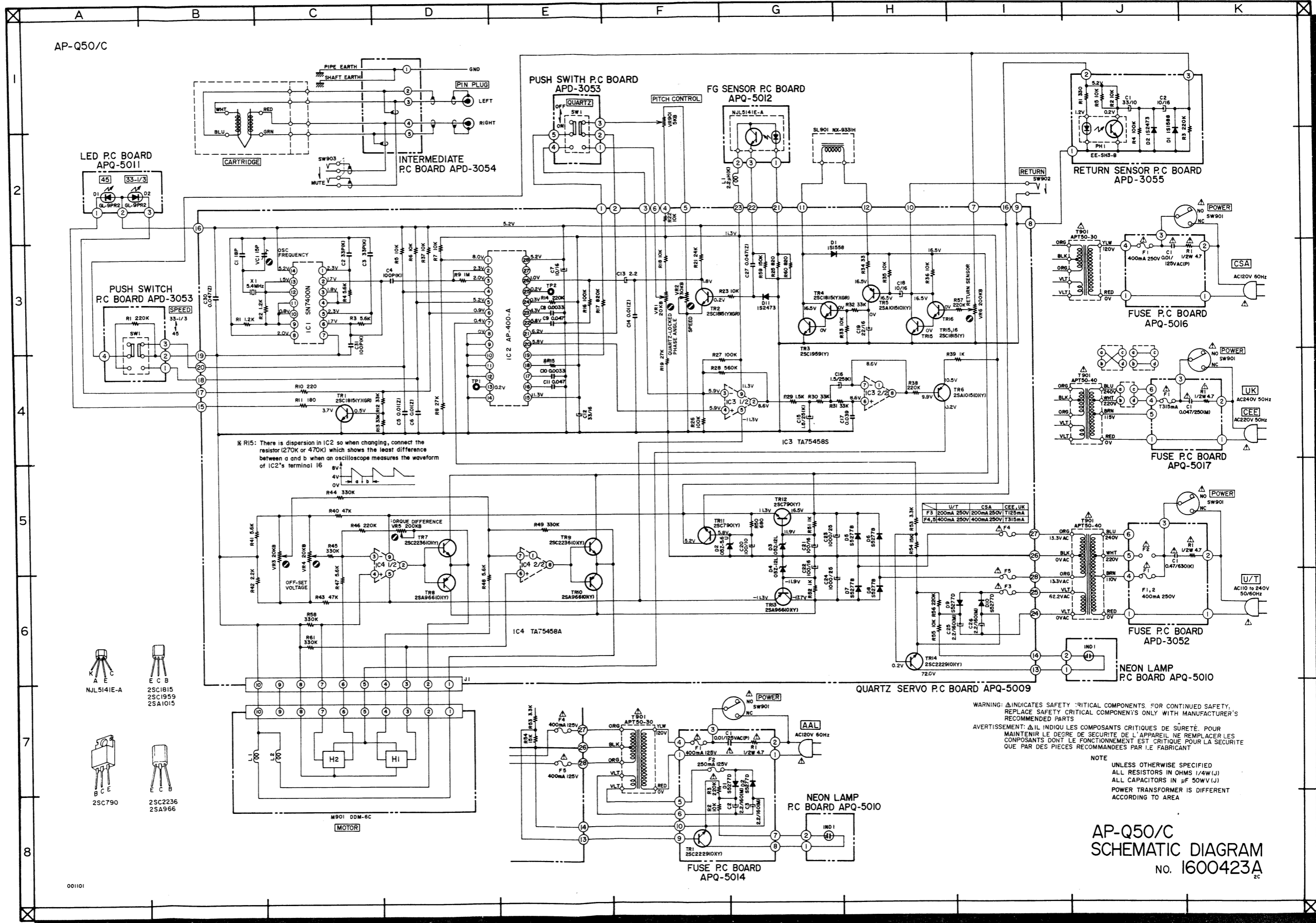

\* R15: There is dispersion in IC2 so when changing, connect the resistor (270K or 470K) which shows the least difference between a and b when an oscilloscope measures the waveform of IC2's terminal 16

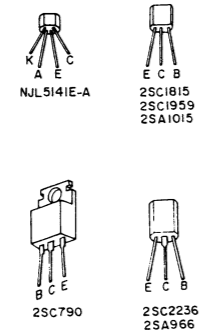
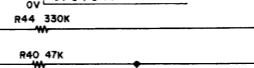

WARNING: Δ INDICATES SAFETY CRITICAL COMPONENTS. FOR CONTINUED SAFETY, REPLACE SAFETY CRITICAL COMPONENTS ONLY WITH MANUFACTURER'S RECOMMENDED PARTS.  
 AVERTISSEMENT: Δ ILL INDIQUE LES COMPOSANTS CRITIQUES DE SÛRETÉ. POUR MAINTENIR LE DEGRÉ DE SÛRETÉ DE L'APPAREIL, NE REMPLACER LES COMPOSANTS DONT LE FONCTIONNEMENT EST CRITIQUE POUR LA SÛRETÉ QUE PAR DES PIÈCES RECOMMANDÉES PAR LE FABRICANT.

NOTE  
 UNLESS OTHERWISE SPECIFIED  
 ALL RESISTORS IN OHMS 1/4W (J)  
 ALL CAPACITORS IN μF 50V (J)  
 POWER TRANSFORMER IS DIFFERENT ACCORDING TO AREA

AP-Q50/C  
 SCHEMATIC DIAGRAM  
 NO. 1600423A



## Kundendienst Informationen

Akai Deutschland GmbH  
Am Siebenstein 4  
6072 Dreieich-Buchschlag  
Telefon 061 03/64096  
Telex 04185332 akaid

Nr. A-04 / 81  
Blatt I

Dreieich, 27.03.1981  
wfs

Betr.: AP-D 30 / C

1. Die Gängigkeit des Geschwindigkeits-Umschalters kann durch Entfernen der Knopf-Feder (Pos. 5-30 auf Seite 43 des Service-Manuals, Bestell-Nr. ZG-325446) verbessert werden.

Diese Änderung wird werksseitig ab Mai 1980 vorgenommen.

AS-0088

2. Ab Produktion Juni 1980 enthält der Plattenspieler AP-D 30 / C eine neue Rückführungs-Elektronik, die mit dem Service-Manual nicht mehr übereinstimmt.

Dies bedeutet nicht, daß Geräte aus der Produktion vor Juni 1980 geändert oder umgebaut werden müssen!

Bei Defekten der Rückführungs-Automatik in Geräten der neuen Produktion kann das Service-Manual nicht zu Hilfe genommen werden.

In diesem Falle ist die folgende Beschreibung zu beachten:

Auf der D.D.-Servo-Platine (APD-3051) sind einige Bauteile geändert und außerdem sind 3 neue Platinen zusätzlich eingebaut (Return-Control-Platine \*APD-3096, CDS-Platine \*APD-3097 A und LED-Platine \*APD-3097 B).

Fig. 13 zeigt die gesamte Änderung schaltungstechnisch, wobei die Änderung selbst eingerahmt ist.

Eine nochmalige Schaltung der Änderung zeigt Fig. 14; hier sind alle zu ändernden Bauteile bzw. Punkte mit einem Pfeil gekennzeichnet.

Auf den drei neuen Platinen befinden sich die folgenden Bauteile:

a. Return-Control-Platine:

TR-1,2	Transistor 2 SC 1815	Best.-Nr. ET-305221
IC-1	IC TA-75458 P	Best.-Nr. EI-306703
D-3	Zenerdiode 05Z-8,2 U	Best.-Nr. ED-326835
VR-1	Einstellregler 10 K	Best.-Nr. EV-522630

b. LED-Platine:

D-1	LED TLR-103	Best.-Nr. ED-325341
-----	-------------	---------------------

c. CDS-Platine:

CDS-1	CDS MPY-12C28 H/A.K.	Best.-Nr. ET-325339
-------	----------------------	---------------------

Die Return-Control-Platine ist nach der Reparatur neu zu justieren.  
Die Nachjustage erfolgt nach den folgenden 2 Punkten:

- a. Regler VR-1 so einstellen, daß die Basisspannung am TR-1 (2 SC 1815) 3,5 V beträgt (+ 0,3 V). Der Plattenspieler muß dabei laufen.
- b. Danach müssen die Einstellungen von Seite 10 des Service-Manuals wiederholt werden.

AS-0088



# AKAI

## Kundendienst Informationen

Akai Deutschland GmbH  
Am Siebenstein 4  
6072 Dreieich-Buchsschlag  
Telefon 061 03/6 40 96  
Telex 04 185 332 akaid

Nr. A-04/81  
Blatt II

Dreieich, 27.03.81  
wfs

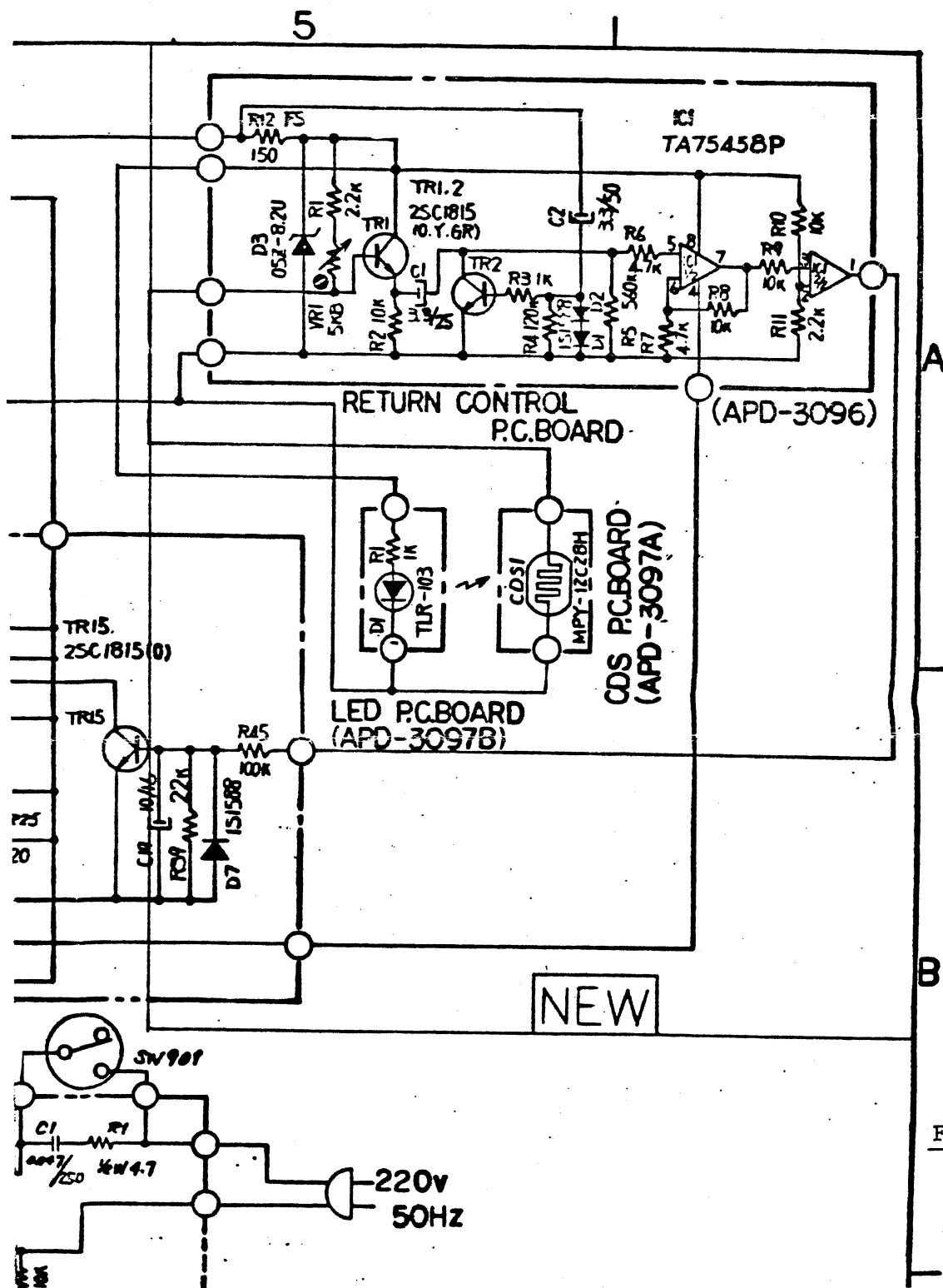

Fig. 13

Akai Deutschland GmbH  
Am Siebenstein 4  
6072 Dreieich-Buchsschlag  
Telefon 06103/64096  
Telex 04185 332 akaid

Nr. A-04 / 81  
Blatt III

Dreieich, 27.03.1981  
wfs

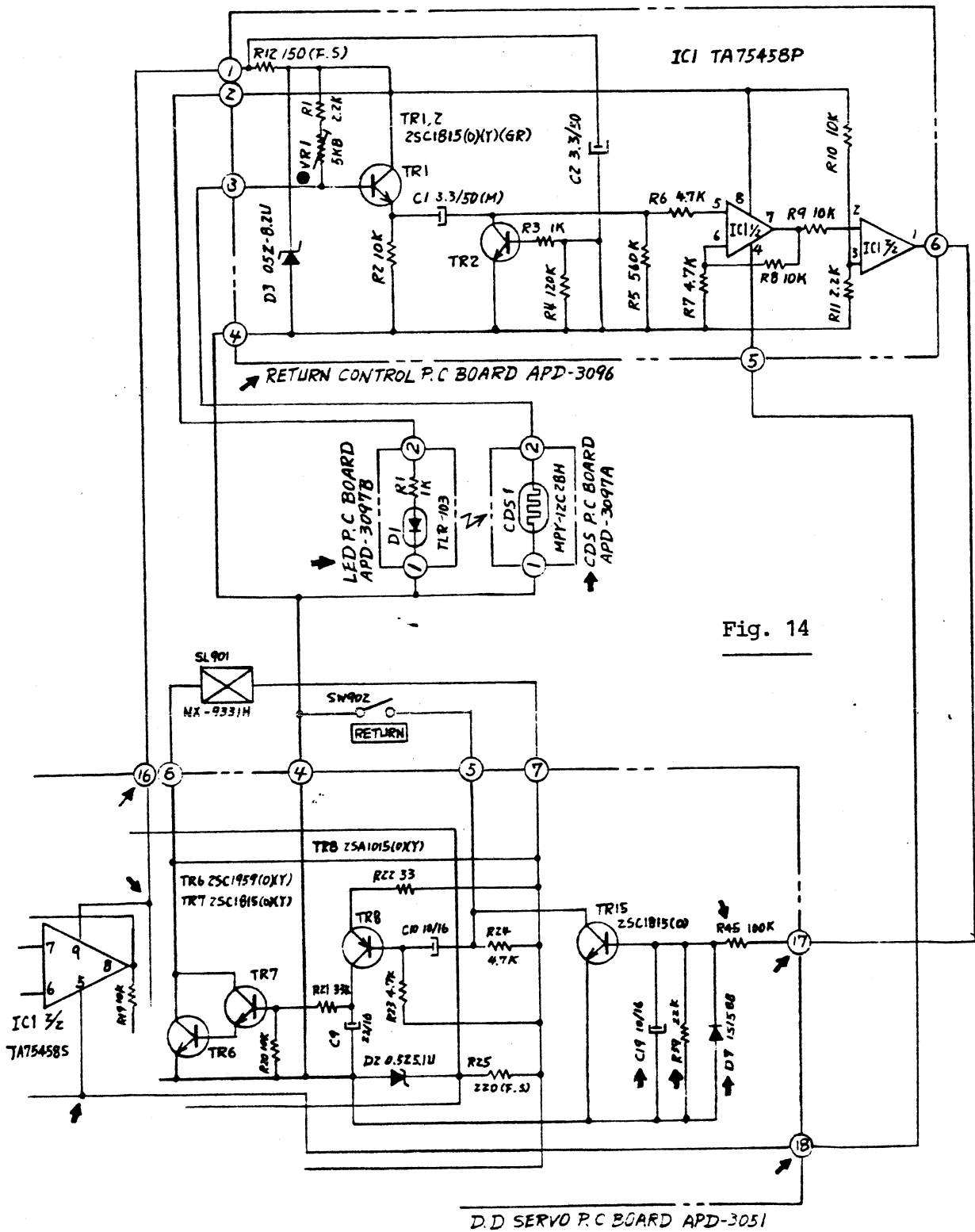

Fig. 14



# Kundendienst Informationen

Akai Deutschland GmbH  
Am Siebenstein 4  
6072 Dreieich-Buchsschlag  
Telefon 06103/64096  
Telex 04185332 akaid

Nr. A-04 / 81  
Blatt IV

Dreieich, 27.03.1981  
wfs

Betr.: AP-D 30 / C

3. Ein im Schaltbild des Service-Manuals enthaltener Schaltungs-Fehler soll hiermit berichtigt werden.  
Siehe dazu Fig. 15.

AS-0088

