

HiFi ENGINE[®]

For more Hi-Fi manuals and set-up information
please visit www.hifiengine.com



Sound Shaper[®]

Stereo Frequency Equalizer

SS-315X

Owner's Manual



Rack mounting handles supplied optionally for USA and Europe version.

Congratulations!

Audio Dynamics Corporation (ADC) is proud to provide the ultimate value in design and development of a 10 band graphic equalizer with a real time frequency spectrum analyzer, the Sound Shaper SS-315X for your superior sound analysis. The Sound Shaper SS-315X uses a fluorescent indicator tube which has 100 separate segments plus 10 segments average response indicator for display to analyze sound source frequencies and room acoustics.

Audio fans and music enthusiasts like yourself look forward to be able to enjoy the highest possible degree of sound quality when listening to their favorite music.

Simply using high-cost, high-quality components, however, does not in itself guarantee that the listener will be able to obtain this sound quality.

A wide variety of factors, including the nature of the listening environment as well as the placement of speakers, play a major role in the acoustic quality of any music system. To further enhance the effectiveness of

the audio equalizer, ADC has developed the ultimate component in audio measuring equipment: the new SS-315X, the graphic equalizer with a real time frequency spectrum analyzer.

The SS-315X offers the listener positive visual confirmation of all sound compensation made, having combined a graphic equalizer and spectrum analyzer both into one unit.

The fluorescent indicator tube's display, which allows visual monitoring of all frequencies, plus average response, adds a further dimension of pleasure to the use of this superior component.



A high quality electret condenser microphone has been developed exclusively for pink noise measurement and is included with your SS-315X. In addition to the excellent styling, your SS-315X has been carefully engineered to give you trouble-free performance and many years of listening enjoyment.

WARNING:
To prevent fire or shock hazard, do not expose this appliance to rain or moisture.

In the space provided below, record the serial number of your unit, located on the back of the cabinet.

Unit description
STEREO FREQUENCY EQUALIZER
Sound Shaper SS-315X

Serial No. _____
Retain this number for future reference

	CAUTION RISK OF ELECTRIC SHOCK DO NOT OPEN	
CAUTION: TO REDUCE THE RISK OF ELECTRIC SHOCK, DO NOT REMOVE COVER (OR BACK). NO USER-SERVICEABLE PARTS INSIDE. REFER SERVICING TO QUALIFIED SERVICE PERSONNEL.		



This symbol is intended to alert you of the presence of uninsulated dangerous voltage within the unit's enclosure that may be of sufficient magnitude to constitute a risk of electric shock to persons.



This symbol is intended to alert you of the presence of important operating and maintenance instructions in the literature accompanying the unit.

Installation

As with other quality sound equipment, adequate ventilation will extend the trouble-free life of your equalizer. You should not install this unit in an overly confined area along with other heat generating equipment.

As for the PX and USA version model, an unswitched AC outlet is available on the rear panel of your unit for connecting other sound equipment accessories and is limited to 200W maximum.

Connect the line cord to an AC outlet providing the proper AC voltage. The power consumed is 20W and if available, the switched accessory outlet of your amplifier may be used to turn the unit on or off with your sound system's main power switch.

Voltage conversion (PX version only)

The voltage selector is provided for PX version only.

If you ever need to change the voltage setting, unscrew the small voltage cover plate near the ac cord, move the switch with a small driver, turn the plate upside down (180°, in other words, which exposes the switch in its new voltage position), and screw it back on. Don't turn the plate over.

Warning: Be sure to remove the power cord from the AC outlet before changing the setting.

Use a screw driver to remove two screws securing the cover to the voltage selector. Adjust the indicator (white stripe) on the selector as follows:

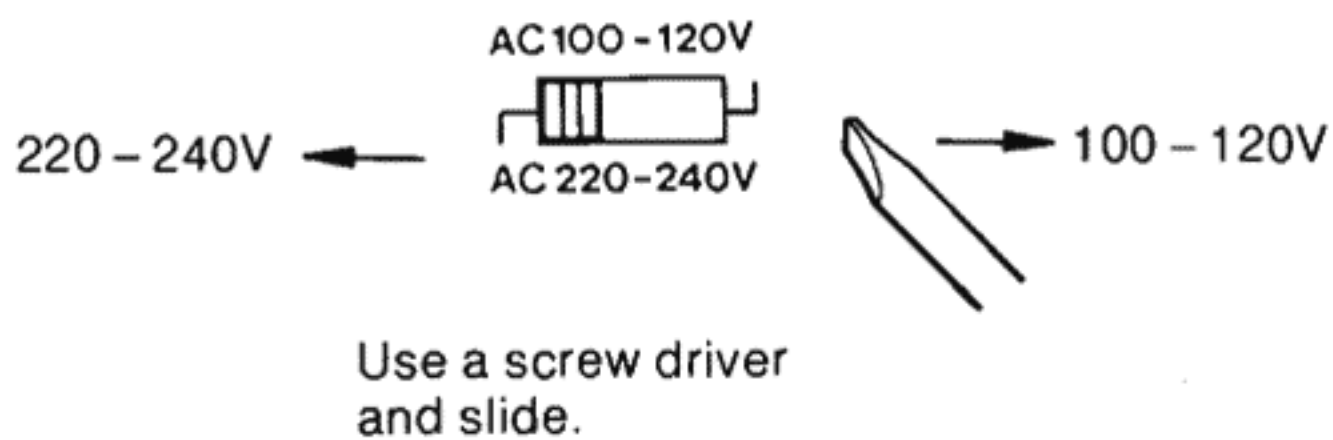
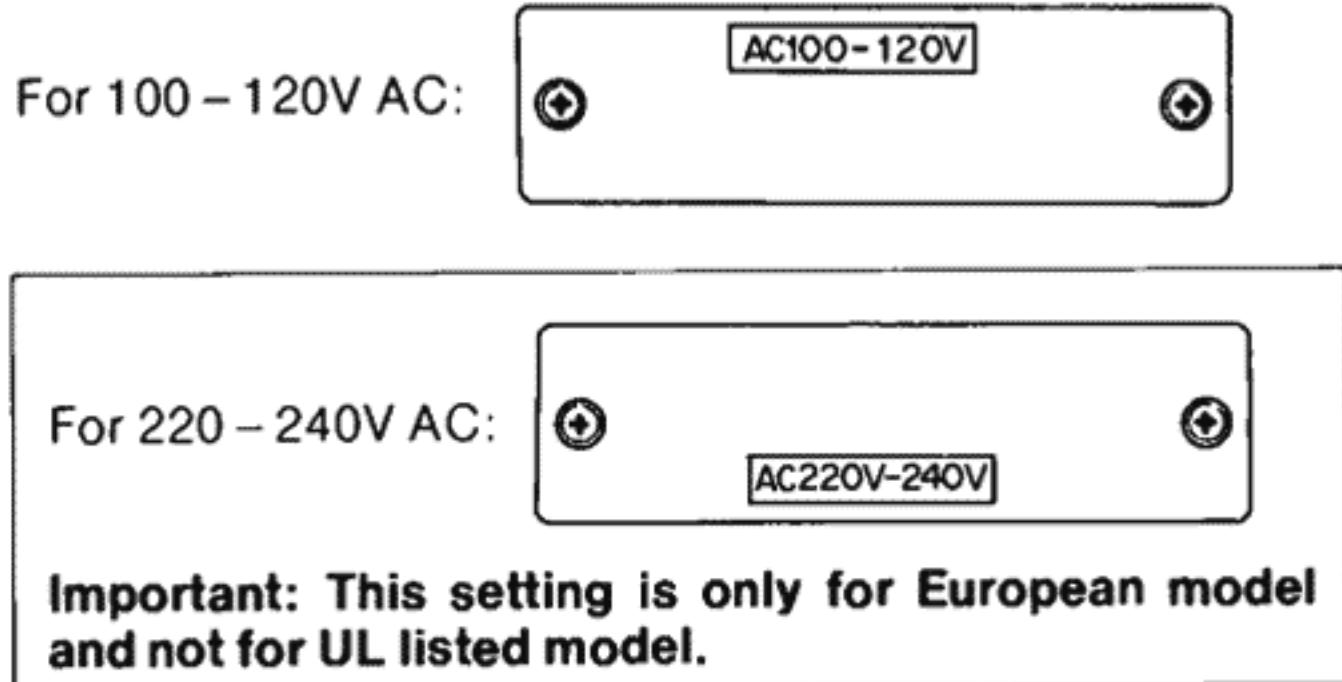

For customers in the U. K. – Important for your safety

The wires in this mains lead are coloured in accordance with the following code:

Blue: Neutral
Brown: Live

As the colours of the wires in the mains lead of this apparatus may not correspond with the coloured markings identifying the terminals in your plug, proceed as follows: The wire which is coloured blue must be connected to the terminal which is marked by the letter N or coloured black.

The wire which is coloured brown must be connected to the terminal which is marked with the letter L or coloured red.

Warning: Do not connect any wire to the larger pin marked E or \perp when wiring a plug. Ensure that all terminals are securely tightened and that no loose strands of wire exist.

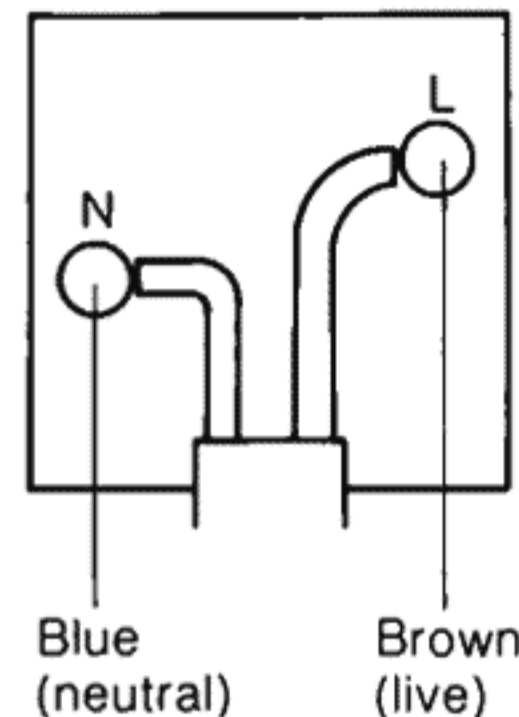

Important..... before operating the equalizer

All equalizers are designed for 'unity gain', in other words, the level of signal output is the same as the level of signal input **when all frequency controls are set to FLAT position.**

If one or several frequency controls are boosted in either or both channels (stereo), the output level from your equalizer will increase within the range of frequencies affected by those controls, thereby increasing the sound level or power output of your amplifier. Depending on the master volume control setting, this can result in overdriving of the power amplifier and/or speaker system and incurring possible damage.

It is suggested that you reduce the master volume control setting of your sound system before switching the equalizer in or out of the system and then restore the master volume control setting to your listening preference.

Do not use the equalizer to increase volume, it is not an amplifier, it is designed to tailor the frequency response of your system, either to your personal preference or help correct deficiencies of the sound system or room acoustics.

Connections

Your system must have a tape monitor switch (marked TAPE MONITOR etc.) which must be left in the on position. This switch is usually a front panel control of the preamplifier, integrated amplifier or receiver. If your system provides a loudness switch on the preamplifier, etc., set the switch off.

- For detailed connecting instructions, see next page.
- A pair of audio cable is supplied with the unit.

Power requirements

Power requirements for electrical equipment differ from area to area.

Please ensure that your machine meets the power requirements in your area.

If in doubt, consult a qualified electrician.

100V, 50 Hz for Japan

120V, 60 Hz for U.S.A

220V, 50 Hz for Europe except U.K.

240V, 50 Hz for U.K. and Australia.

AC OUTLET UNSWITCHED (PX and USA version)

The AC OUTLET receptacle may be used to power the one of associated equipment. Plug the power plug from the associated equipment into this receptacle.

Important! Do not plug in any equipment with the rated power consumption greater than 200W.

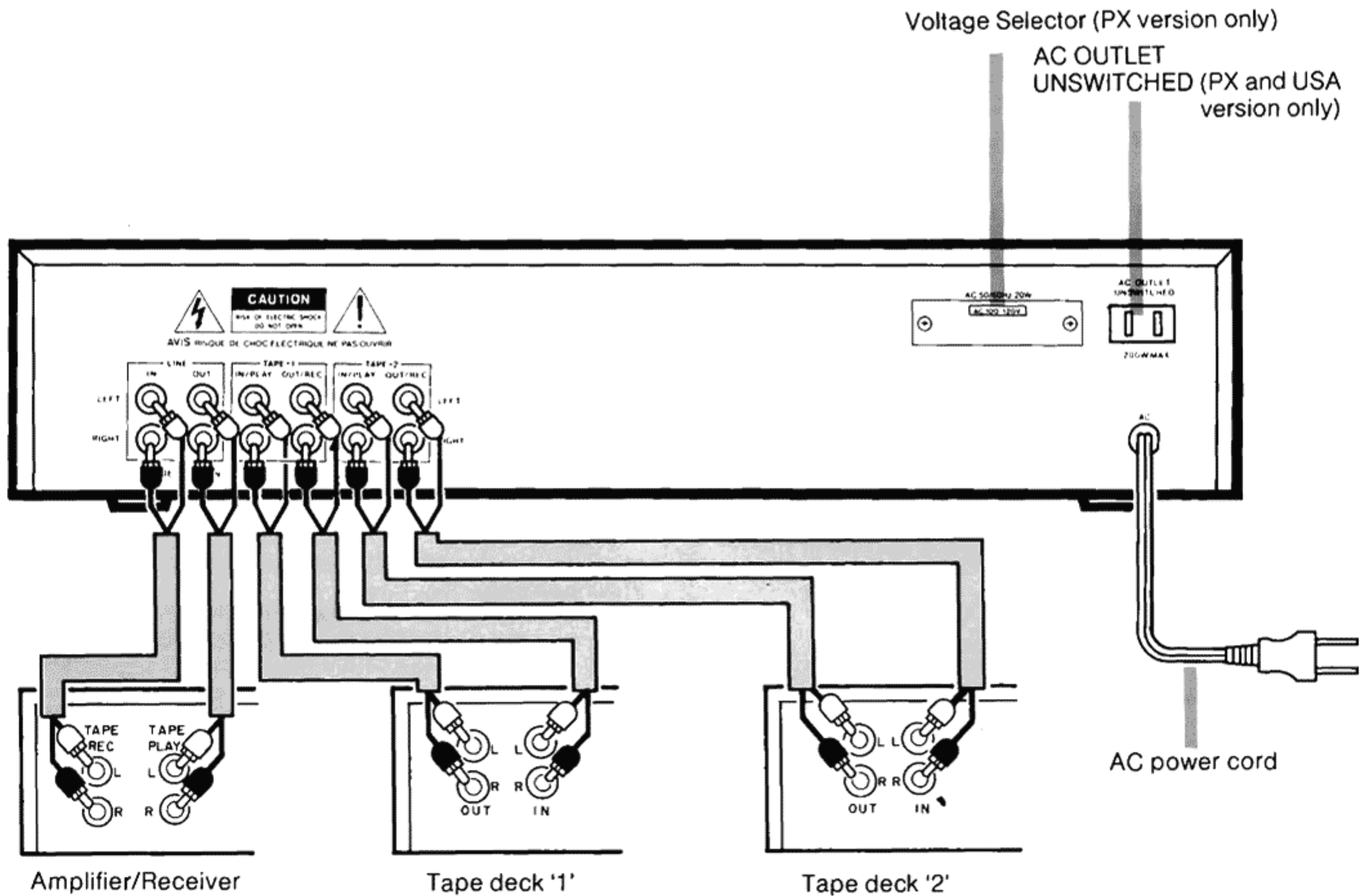

Connecting the associated equipment

1 Amplifier/receiver

Connect the LEFT and RIGHT LINE IN jacks on the SS-315X to the tape recording jacks on your amplifier or receiver (marked as TAPE REC or TAPE OUT etc.).

Connect the LEFT and RIGHT LINE OUT jacks on the SS-315X to the tape deck input jacks on your amplifier or receiver (marked as TAPE PLAY or TAPE MONITOR etc.)

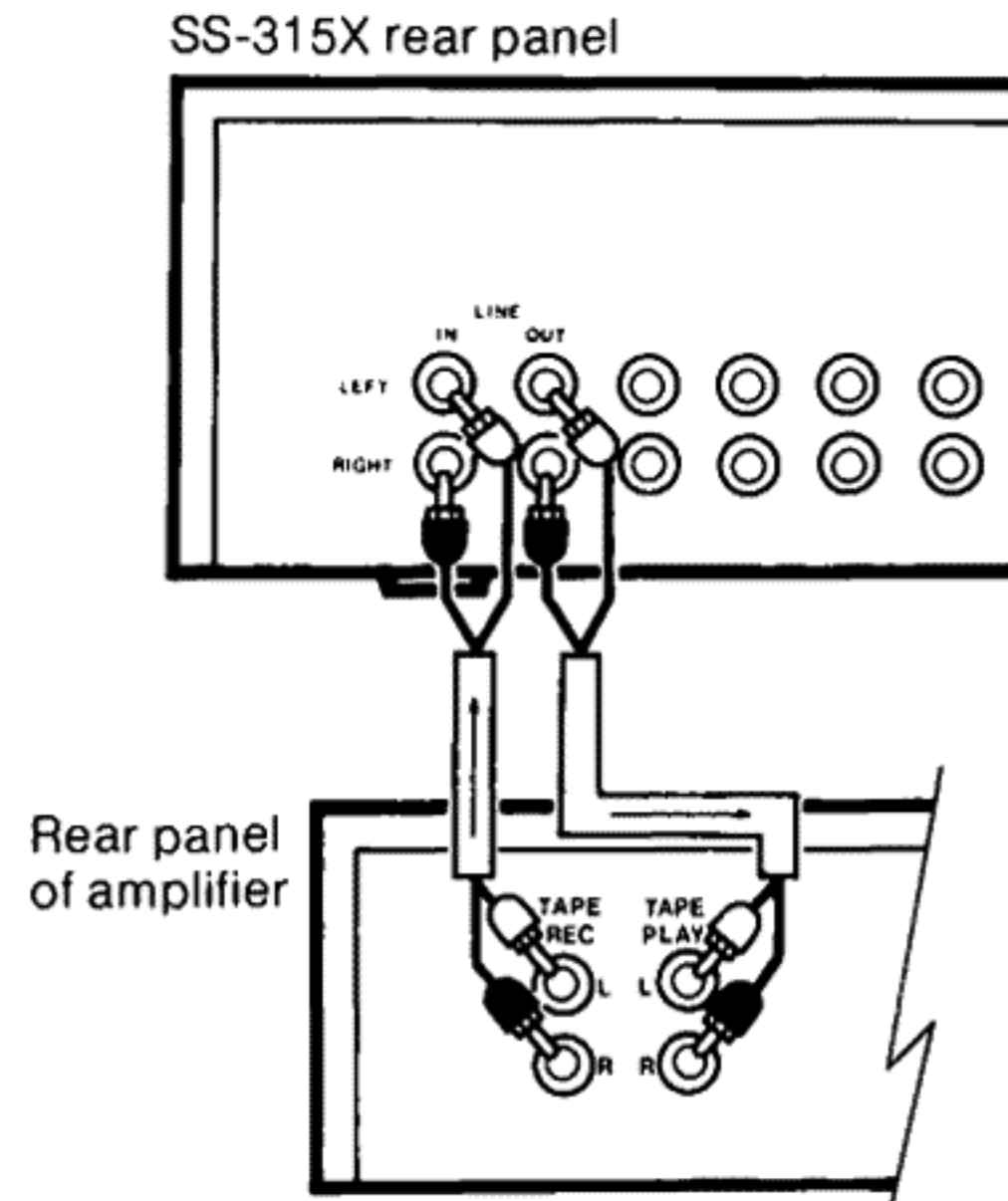

2 Tape deck/recorder

The SS-315X is equipped with two inputs/outputs for connection of up to two tape decks – TAPE 1 and TAPE 2.

Connect the IN/PLAY jacks to the play back output of the tape deck (marked LINE OUT or MONITOR etc.).

Connect the OUT/REC jacks to the recording input jacks of the tape deck (marked LINE IN or RECORD etc.)

SS-315X rear panel

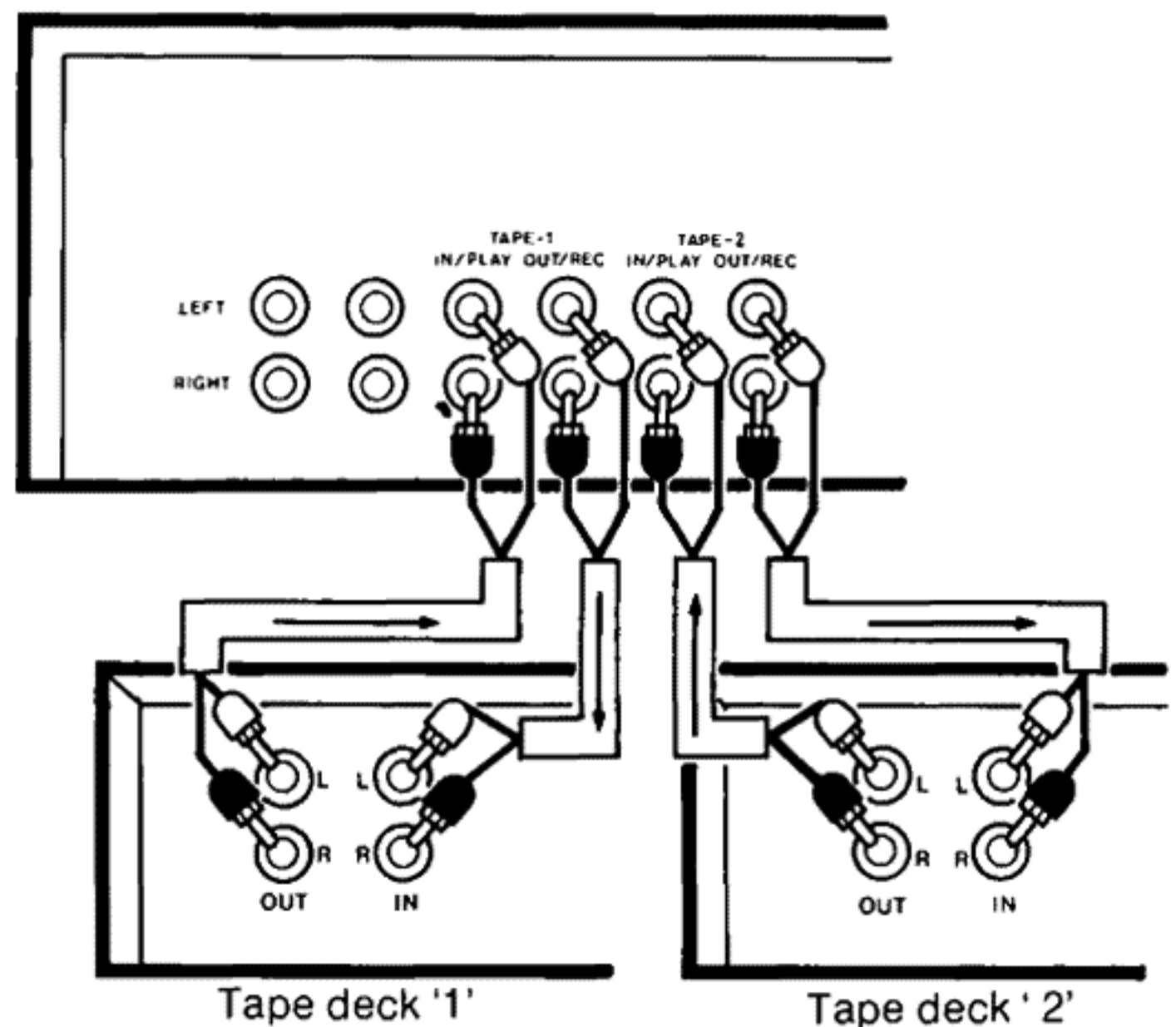

Controls and Functions

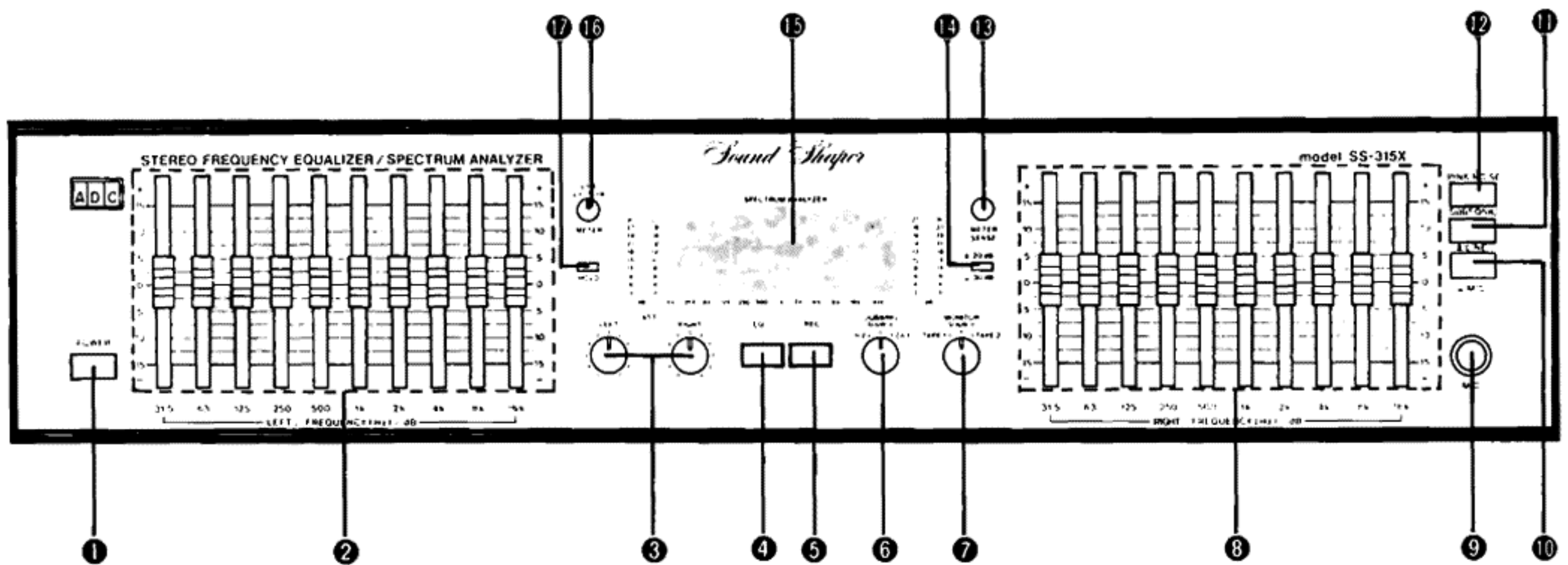

1 POWER switch

Depress this switch to turn the unit on or off. The 'ADC' emblem above the switch will be illuminated when the unit is on. When power is off, audio may not flow through the unit.

2 LEFT/FREQUENCY (Hz)/dB level controls

Each control varies by ± 15 dB the level of a small range of audio frequencies which is centered around the frequency marked over each control. These controls are operative when the EQ button is depressed. See page 14.

3 ATT/LEFT-RIGHT controls

When these controls are set to the fully clockwise position the equalizer provides 'unity gain' which means that the level of signal output is the same as the level of signal input when all frequency controls are set to flat (0) position. When these controls are rotated counterclockwise the output level of the equalizer is attenuated.

These controls also affect the sensitivity of the SPECTRUM ANALYZER; however do not affect the recording signal onto the cassette deck(s) when making a recording.

4 EQ button

Depress to use the FREQUENCY (Hz) level controls (the control LEDs turn on). This button is also depressed to make an equalized tape recording. Release this button to bypass the equalizer when no equalization is desired (the control LEDs turn off). This button also activates the SUBSONIC FILTER button.

5 REC button

Depress this button to make a frequency equalized tape recording or dubbing (the EQ button must be depressed for equalized recording).

6 DUBBING selector

Used to dub (copy) a tape program onto another tape deck – in two way. Set this selector to SOURCE when recording the LINE inputs on the tape decks. To make an equalized dubbing, the EQ and the REC buttons should be depressed. This selector will still function when the EQ button is released (off).

7 MONITOR selector

Selects the output of the either of two tape decks connected to the TAPE 1 or TAPE 2 jacks. Set this selector to SOURCE to listen to the LINE inputs.

8 RIGHT/FREQUENCY (Hz)/dB level controls

Operates in the same manner as the LEFT/FREQUENCY (Hz)/dB level controls except that these controls provide

adjustment of the right channel level.

9 MIC jack

Depress the LINE-MIC button (to MIC) and this is the microphone input of the spectrum analyzer and where you connect the microphone supplied with the equalizer. Connect the microphone supplied only as the use of other microphones – dynamic type etc. will damage your system. (Never connect a headphone here!)

10 LINE-MIC button

Depress this button to make the analyzer measurements of the signal from the microphone. When released out (LINE), the analyzer measurements are made from the LINE output signal.

11 SUBSONIC FILTER button

Operates when the EQ button is depressed and low frequency hum or turntable rumble does not affect your program material. The SUBSONIC FILTER circuit functions to attenuate the output below 15 Hz by -18 dB/octave. Subsonic filtered signals can be recorded on the tape deck (s) if the REC and EQ buttons are depressed.

12 PINK NOISE button

Press this button (the MONITOR selector should be set to SOURCE) and a pink noise will be displayed on the SPECTRUM ANALYZER display. Pink noise offers a constant level of noise that eliminates this dB in terms of octave ratings. For details, see page 11.

13 METER SENSE control

Allows you to adjust the sensitivity of the SPECTRUM ANALYZER display so that you can obtain the easiest readout setting in terms of the display 20 dB – 30 dB range selector button.

14 Display 20 dB – 30 dB button

Used to select for a 20 dB or 30 dB readout on the SPECTRUM ANALYZER, in order to show dynamic ranges for the LINE input, microphone input, or pink noise input.

15 SPECTRUM ANALYZER display

A fluorescent display. The graph is divided into ten separate bands plus one average band of all audible frequencies.

16 METER L/L+R/R selector

Allows you to observe the left channel display (L), the right channel display (R), or the mixed (L+R).

17 Display HOLD button

Used to 'freeze' the display at any desired moment. When the button is depressed, the SPECTRUM ANALYZER display will hold the display until the button is released.

To listen to SOURCE programs

1. To listen to the LINE input sources, first select the program – phono, tuner etc. – on your stereo system.
2. Before starting to use the equalizer, set the tape monitor switch of the preamplifier, integrated amplifier, or receiver to on and set the loudness switch and low/high frequency filters (if any) to off.

Note. If your preamplifier etc. is equipped with a REC OUT selector, first set the input selector on the preamplifier etc. to the tape (monitor) position, and set the REC OUT selector to the position which selects the program source you desire to make an equalization.

Typical control settings

Note

indicates the function indicated.

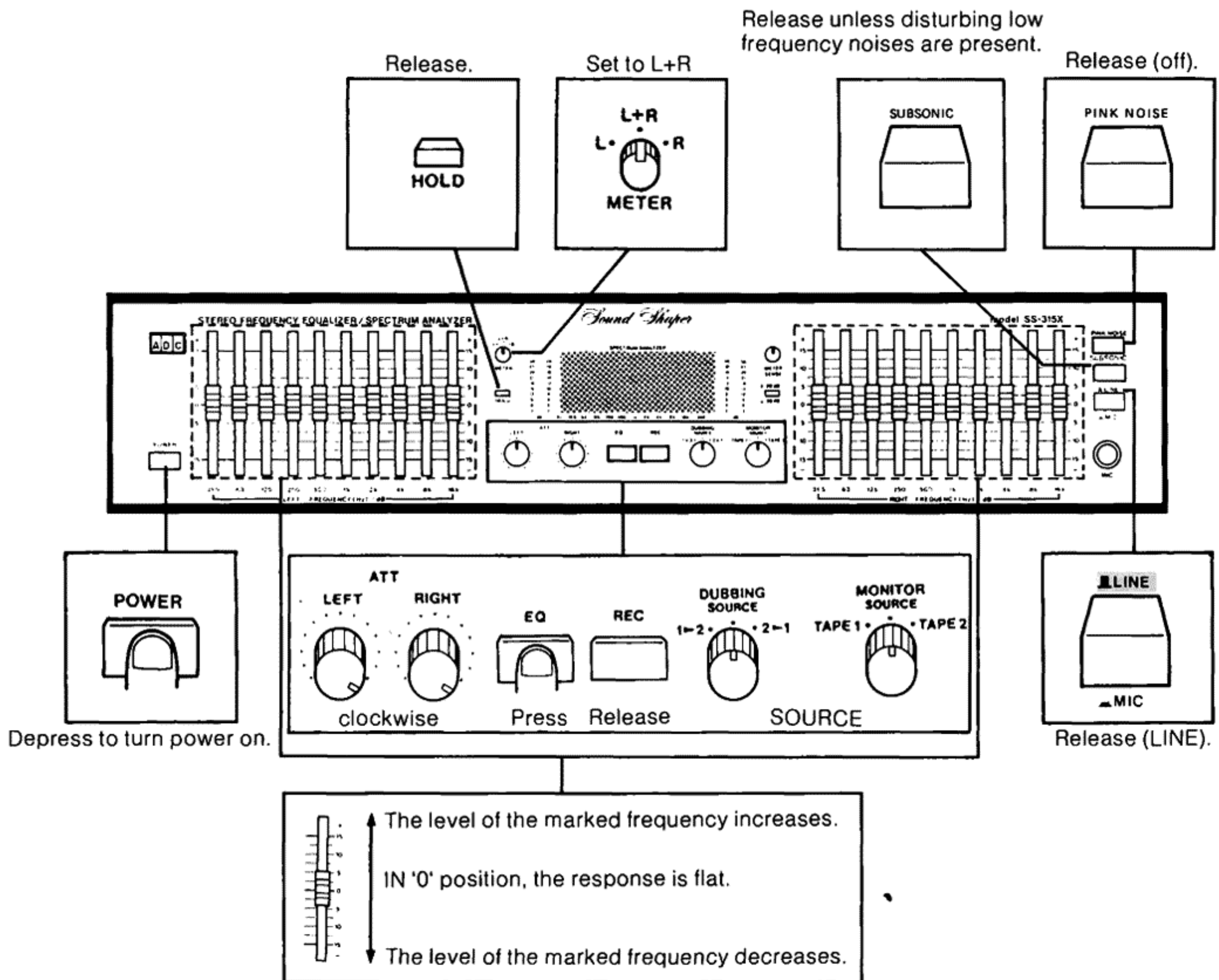

To Listen to TAPE Programs

For simplicity, we use the terms TAPE 1 deck and TAPE 2 deck as the decks connected to the TAPE 1 jacks and the TAPE 2 jacks.

To listen to TAPE 1

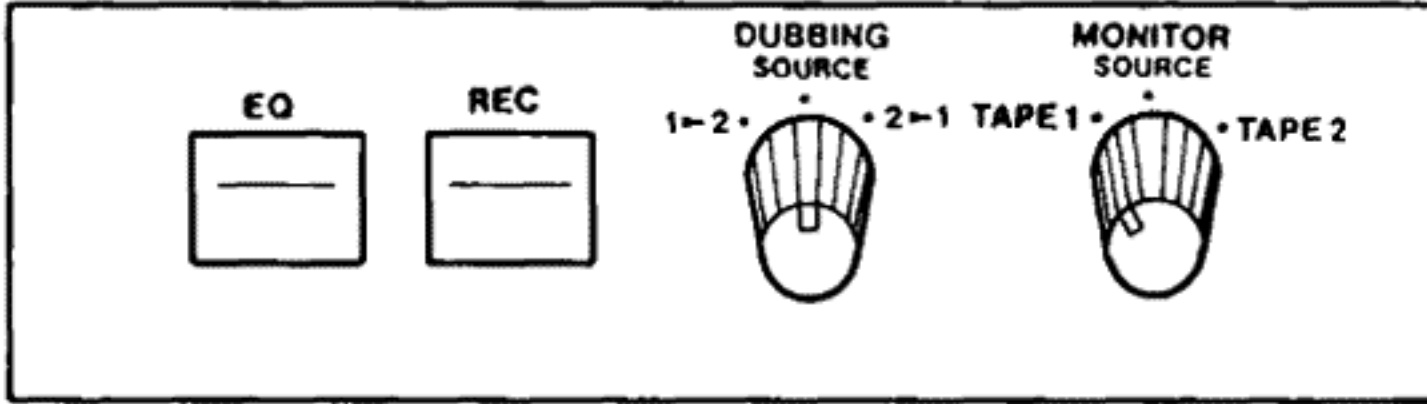

Start playing the tape deck.

To use the FREQUENCY level controls, refer to page 14.

If you wish to listen to equalized tape programs

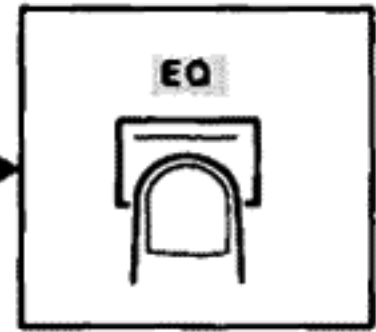

To listen to TAPE 2

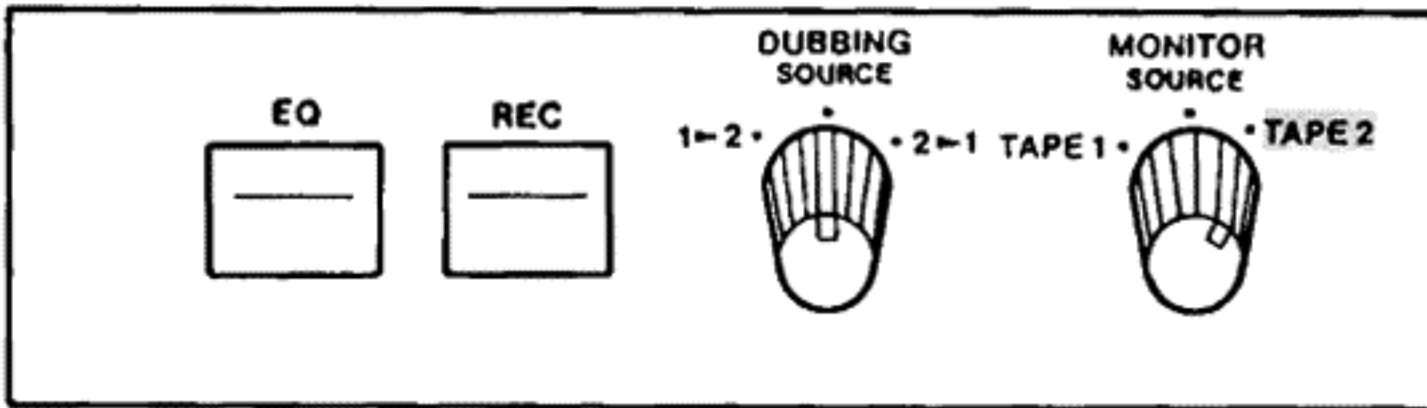

To record the LINE inputs on tape decks

Since the REC output jacks of the TAPE 1 and TAPE 2 will provide the same recording signal simultaneously, you can set both the TAPE 1 and TAPE 2 decks to recording mode for a simultaneous recording.

To make a normal recording

Note. To use the SPECTRUM ANALYZER as a level meter during recording, the display LINE-MIC button should be released (LINE).

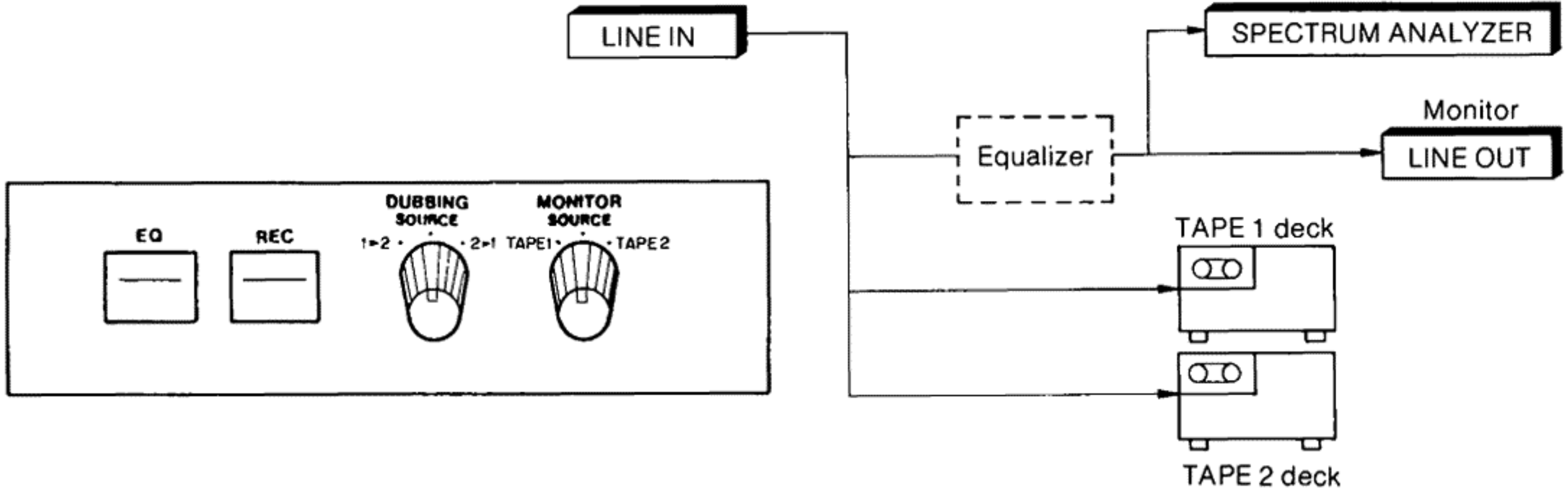

To make an equalized recording

Use this feature when recording from a poor quality program source – old records etc.

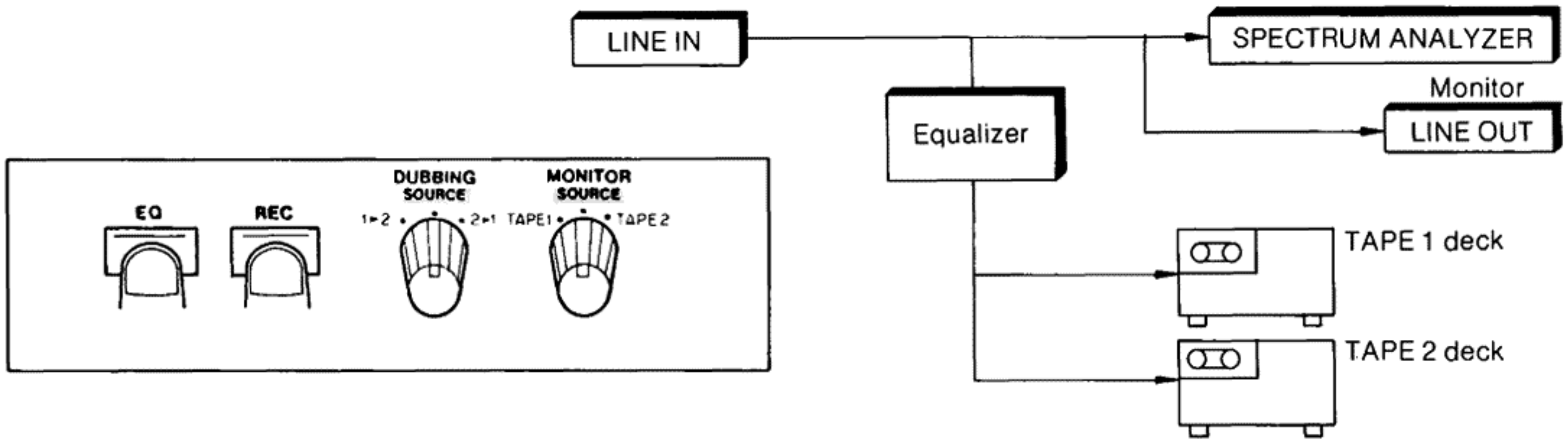

Monitoring the recording

If the tape deck employs independent record and playback heads, a true tape monitoring will be possible. This will enable you to hear the program actually on the tape a fraction of a second after you have recorded it.

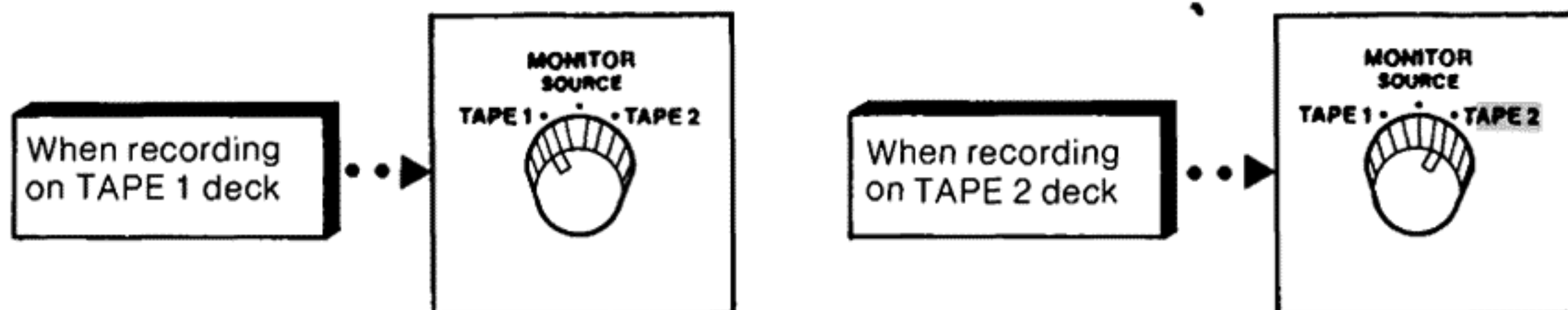

If set to SOURCE position, you can monitor the programs before the programs enter the tape deck and the effect of the equalizer will not be monitored although they are actually used and affect the recording.

Dubbing

From TAPE 1 to TAPE 2

Playback the TAPE 1 and record it on the TAPE 2.

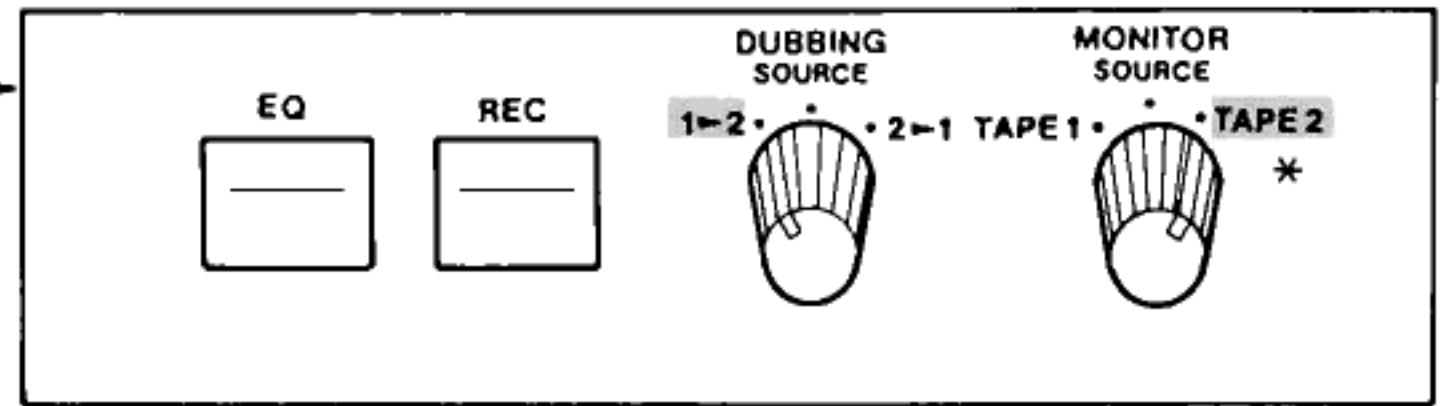

* MONITOR switch

If set to '1', the TAPE 1 signal before it goes to the TAPE 2 input will be monitored.

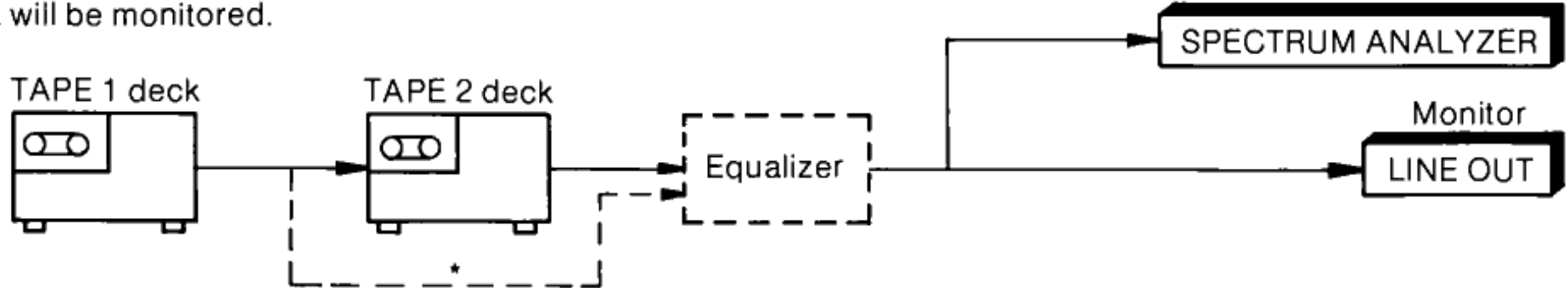

From TAPE 2 to TAPE 1

Playback the TAPE 2 and record it on the TAPE 1.

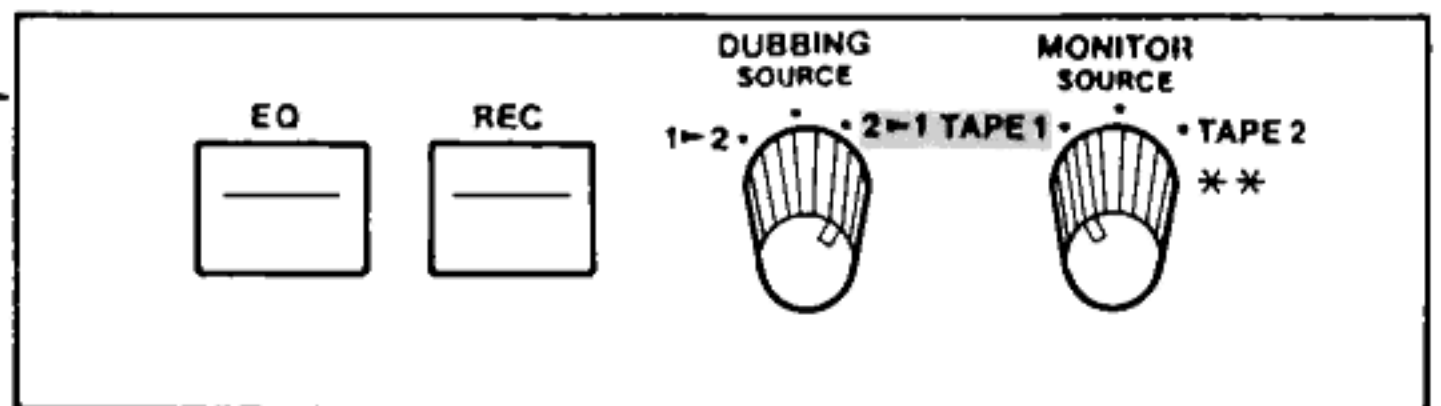

** MONITOR switch

If set to '2', the TAPE 2 signal before it goes to the TAPE 1 will be monitored.

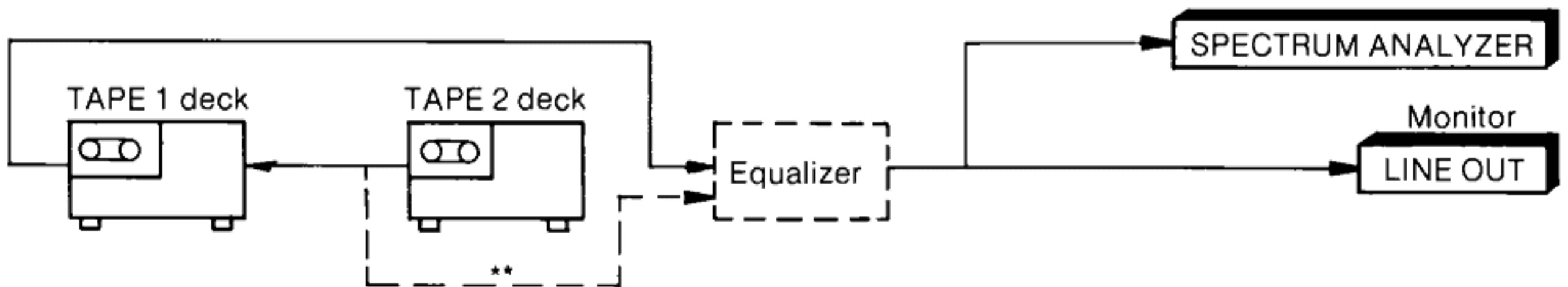

To make an equalized dubbing

Depress the REC button to switch the equalizer in between TAPE 1 and TAPE 2.

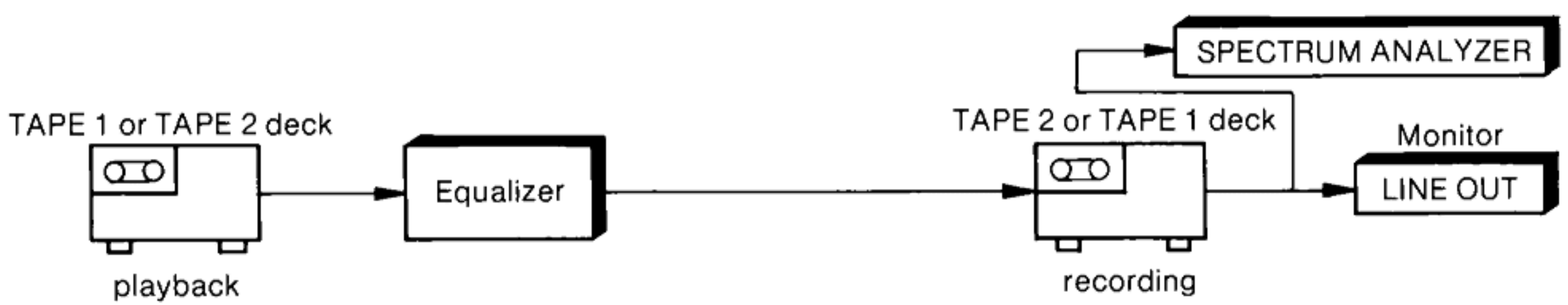
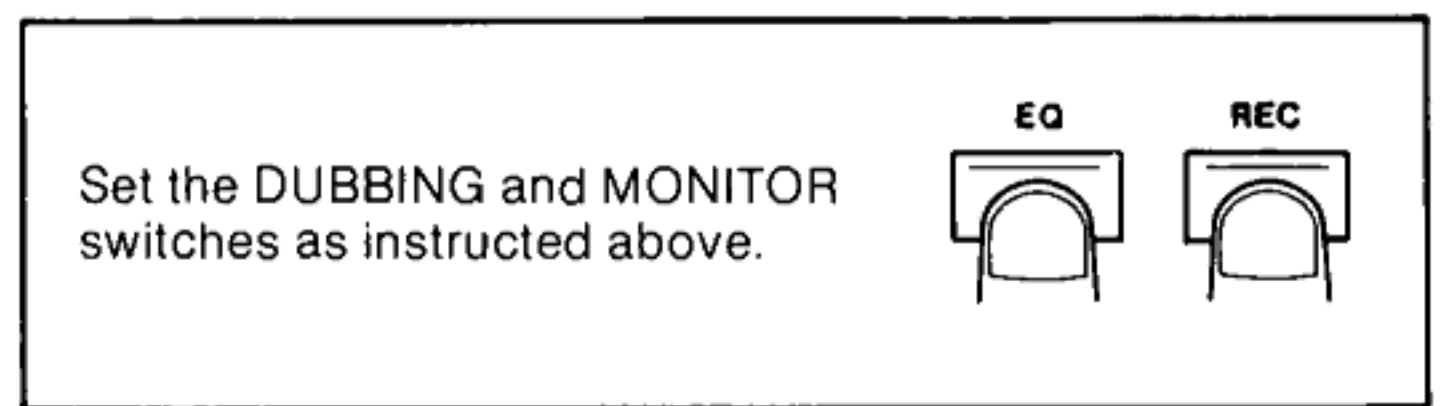

Note. During dubbing process, listening to LINE input programs is possible without disturbing the dubbing process, by setting the MONITOR switch to SOURCE position. The SPECTRUM ANALYZER will indicate the level of the LINE output signals.

Using the SPECTRUM ANALYZER

Real-time analysis of a program

Turn the program up to a comfortable listening level.

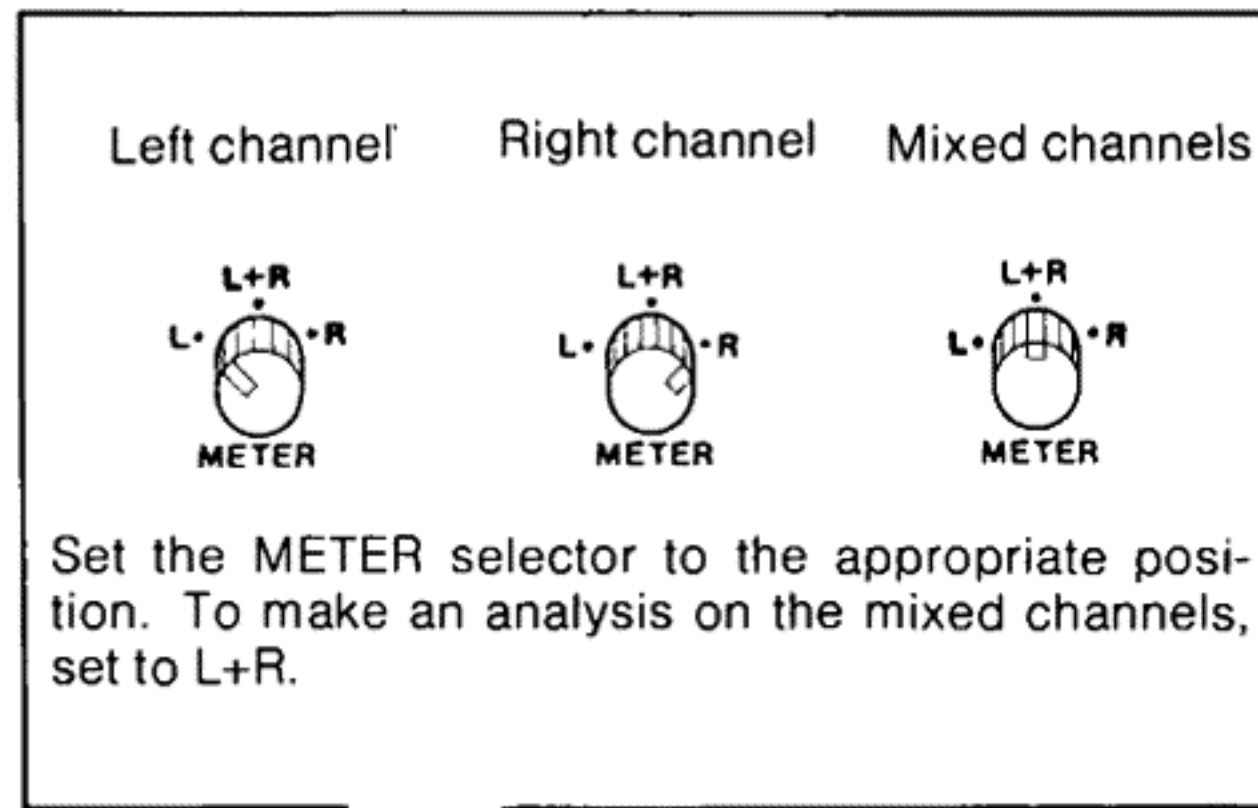

Depress to hold and display the level of a program.
To reset the display, depress the HOLD button again.



Adjust as necessary to roughly center the lighted indicators on the display.

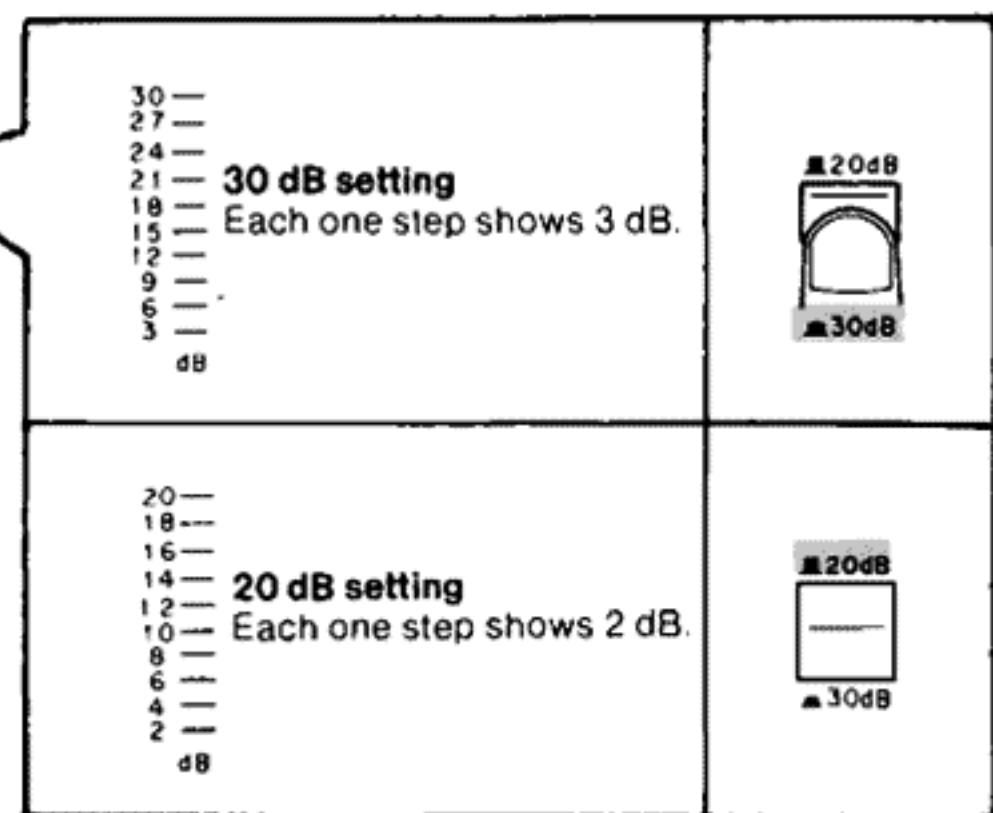

To analyze the program from the preamplifier etc.

LINE
MIC

To analyze the program as it is played in the listening room.¹⁾

LINE
MIC

Locate the microphone centrally between the speakers and approximately 6 feet forward.

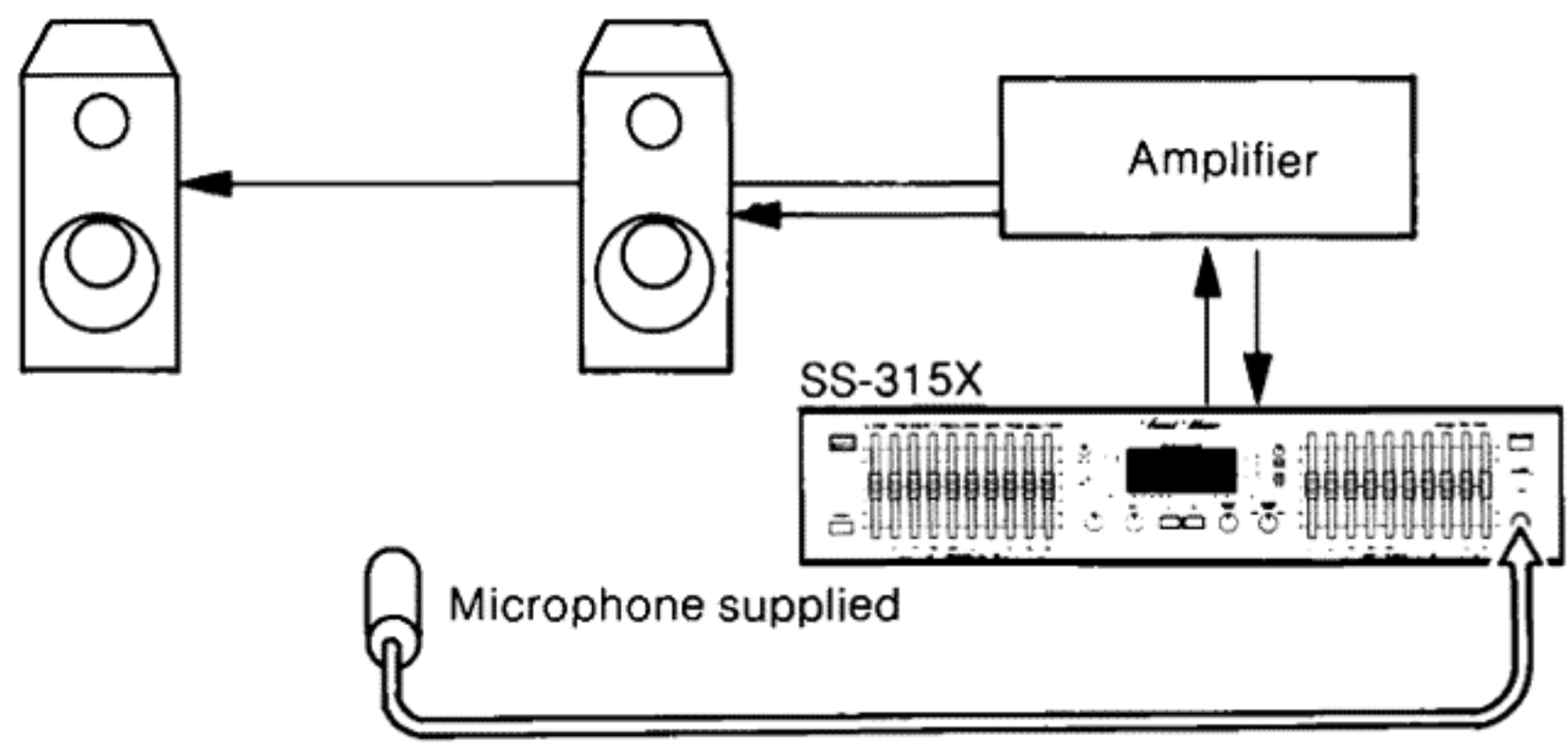

1) Plug the microphone into the MIC jack. The microphone should be placed at a convenient location in the room. For the most accurate measurement of frequency response, the microphone should be placed in a typical listening location, and the grille should be aimed at a point midway between the two loudspeakers.

Real-time analysis for a high-fidelity system (using pink noise)

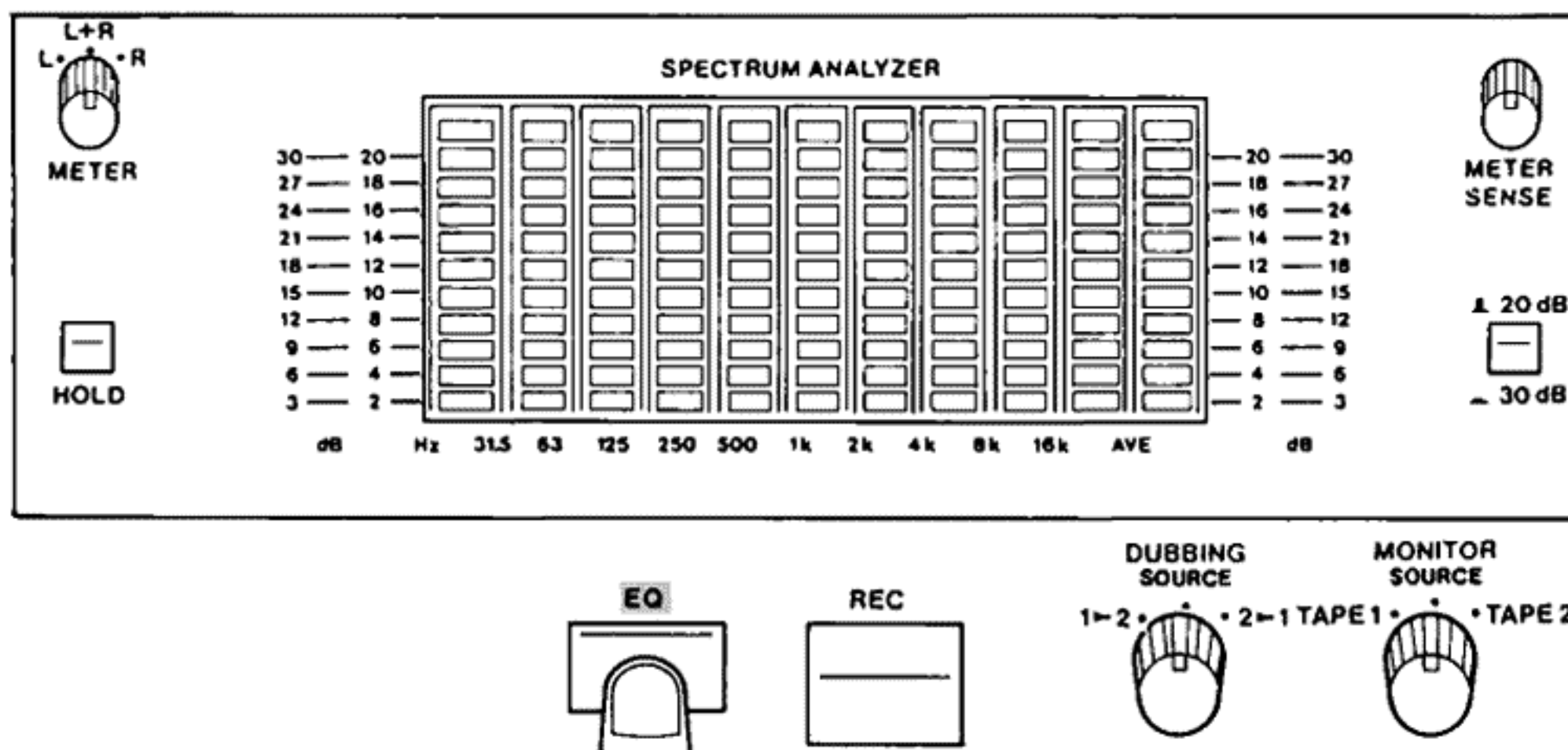

- ① Connect the microphone supplied to the MIC jack of the unit.
- ② Select the channel you desire to make an analysis.
- ③ Depress the LINE-MIC button (MIC).
- ④ By increasing the METER SENSE control, the ambient noise level may be seen on the SPECTRUM ANALYZER display. Most rooms have some reading in the lowest frequencies at the most sensitive setting of the SPECTRUM ANALYZER. This ambient reading is caused by traffic noise, air conditioners, heaters, etc.
- ⑤ Depress the PINK NOISE button (the preamplifier volume control can be raised, if necessary). For accurate readings, the SPECTRUM ANALYZER should now indicate at least 10 dB greater level in each band than the ambient noise level measured.

Caution. Very high levels of pink noise (greater than 95 dB SPL) may damage speakers. Use care in setting the preamplifier volume control.

- ⑥ The SPECTRUM ANALYZER now shows the frequency response of the sound system for that microphone location. Since all FREQUENCY level controls are operative (provided that the EQ button is depressed, of course) in the real-time analysis mode, the effect of a change in equalization can be easily seen on the display.
- ⑦ As the microphone is moved about the room, the effect on frequency response by room boundaries (walls, ceilings, floor, furniture, and speaker placement) can be evaluated.

Adjustment of the FREQUENCY level controls

The FREQUENCY level controls allow individual adjustment of all ten bands for each channel. The appropriate control should be raised to increase level, or lowered to decrease level in a given band.

More than one control may be moved at one time.

If the level of the marked frequency is too high on the display, slide the corresponding FREQUENCY level control downward (toward -15). If it is too low, slide the control upward (toward +15).

Depress the EQ button and operate the FREQUENCY level controls to make adjustments to equalize frequency levels and to achieve optimum compensations in the characteristics of your listening room.



Pink noise test for taperecorder performance

Just as pink noise is used with the SPECTRUM ANALYZER to measure the frequency response of a listening room, it can also show the frequency response of a tape recorder.

The curve shown on the display corresponds to the frequency response obtained from the tape deck at the recording level chosen for that channel.

② Adjust the tape deck recording level to obtain a proper VU meter reading. The frequency response of a cassette deck is usually measured at -20 dB VU to eliminate high frequency saturation effects. Record a few minutes of pink noise on both channels.

① Depress to record pink noise onto the tape deck.

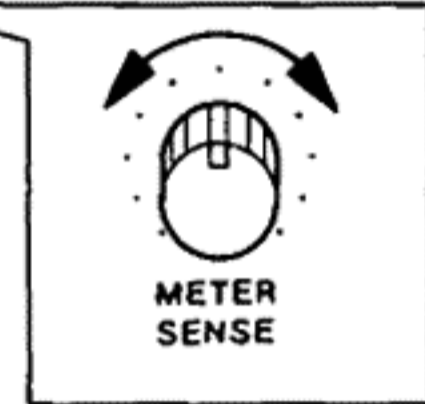
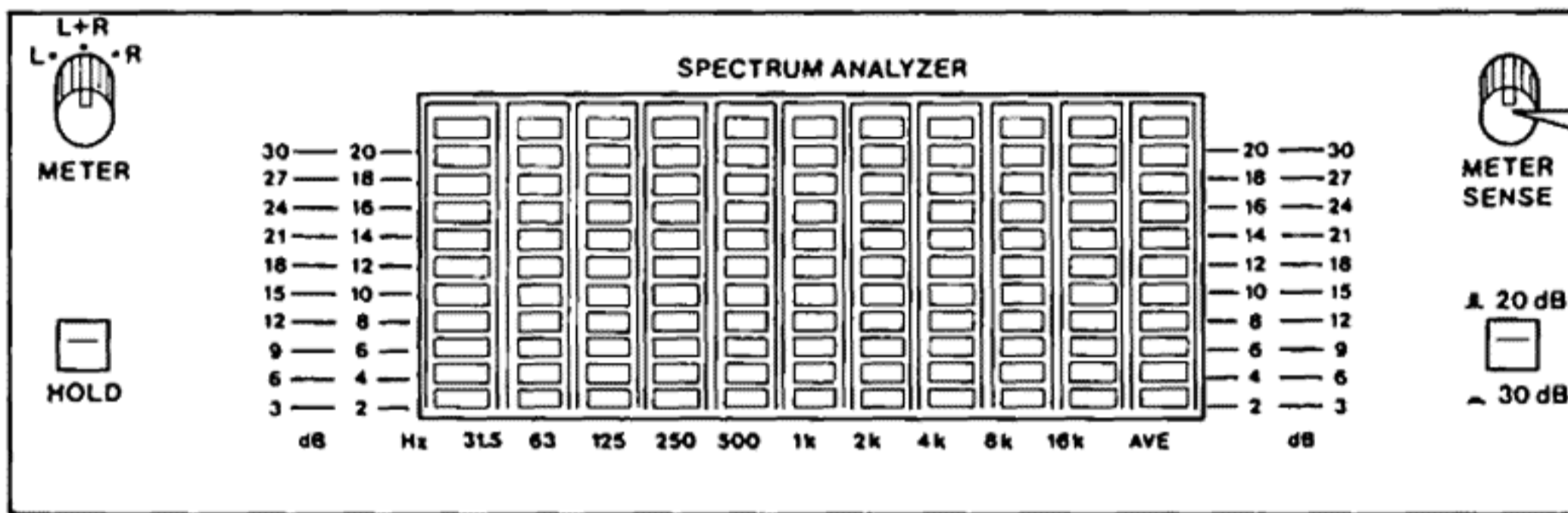
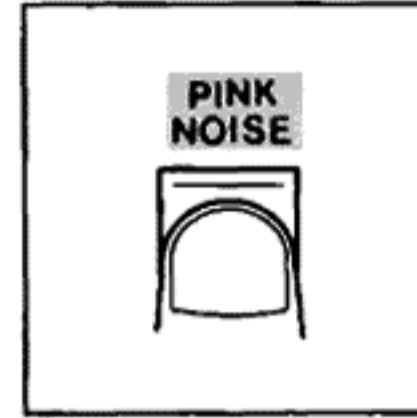

Adjust roughly to center the indicators on the display.

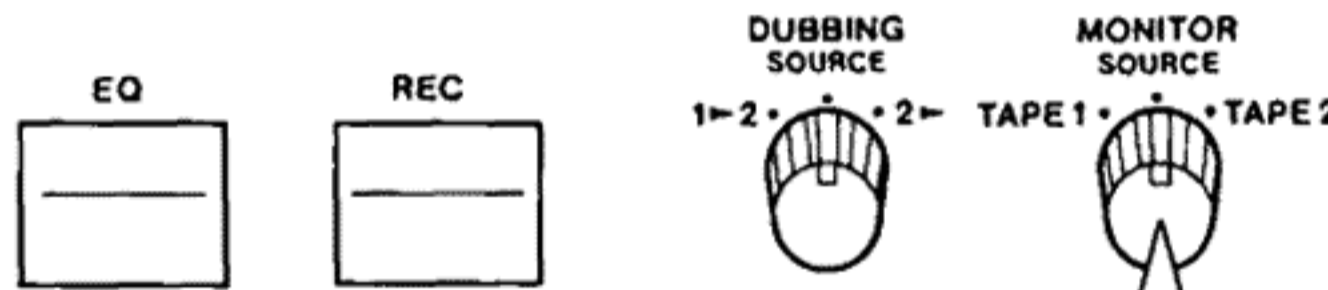

③ Release the PINK NOISE button.

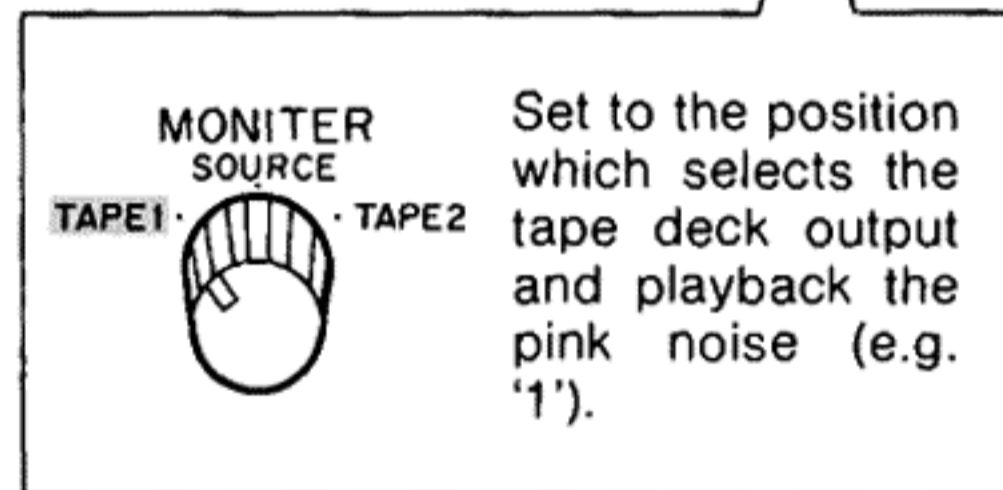

About the pink noise signal

The pink noise signal consists of equal parts of each octave of the audio spectrum, like a deeper form of the white noise you hear between FM radio station or on unoccupied TV channels: an airy rushing sound. White noise exhibits a 3 dB increase per octave as the frequency is increased.

An approximate frequency spectrum of pink noise

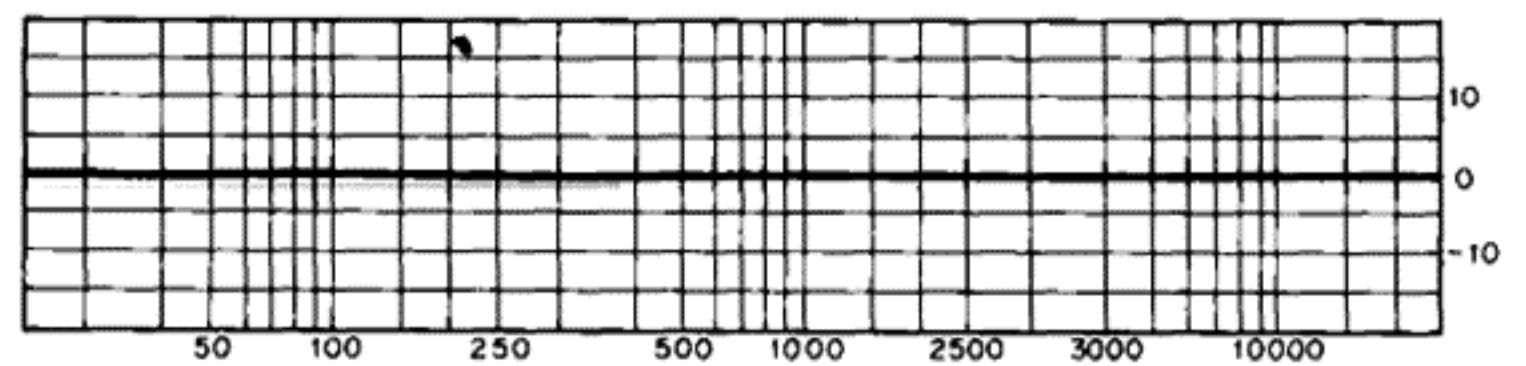

An approximate frequency spectrum of white noise

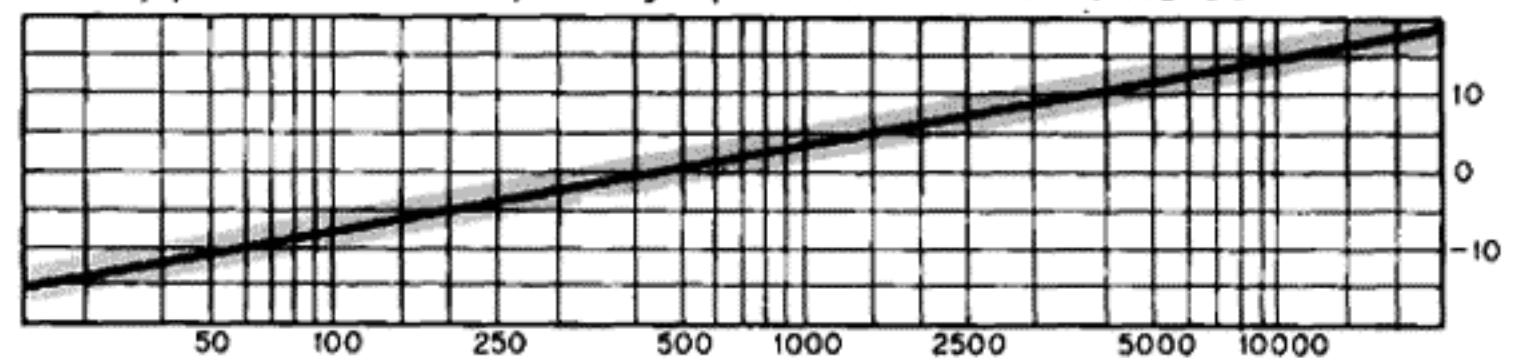

About Frequency equalization

The front panel has 20 controls, 10 per channel. Each control varies by ± 15 dB the level of a small range of audio frequencies which is centered around the frequency marked over each control. In order to achieve a smooth response, controls for adjacent frequencies within each channel must interact. For example, the LEFT 500 Hz control will affect the LEFT 1 kHz control. The net effect of such controls set in the same direction (both in + or both in -) will be greater than the panel marking indicates. The effect of such controls in opposite directions (one + and one -) will be less than indicates. Refer to figures in **Total system equalization** that follow for typical slide control effect.

LED illumination of the FREQUENCY level controls incorporated provides a visual display of the controls depicting graphically the curves you have created, to assist in tailoring the frequency response to your preference.

The musical spectrum

The **Approximate frequency ranges** chart on next page correlates familiar musical instruments with the numerical frequencies that they produce. Given the often talked about musical range of 20 Hz to 20 kHz, it is surprising to see how low musical fundamentals actually are. (Almost all are under 3,500 Hz.) It should be understood however that if all instruments were perceived only by their fundamental frequency output (black bands), they would all sound alike. It is the harmonics or overtones (grey bands) that give each individual instrument its character or timbre and set it apart from the rest.

Interestingly enough, the human ear is more sensitive to certain octaves in the musical spectrum than to others.

Whoever designed this engineering marvel deemed it necessary to tune the ear more toward the midrange frequencies where speech and voice communication occur than to the outer octaves of low bass and high musical overtones. As a result, very small energy changes here will cause a more drastic psychoacoustic effect than larger changes would at the frequency extremes.

In order to discuss the qualitative effects of adjustment in tonal balance, it is best to arbitrarily divide the musical spectrum into five ranges.

The bass (approx. 20 - 140 Hz). There is little musical material with fundamental frequencies below about 60 Hz, and what is normally perceived as low bass material is actually in the 60 - 140 Hz range. The very lowest frequency controls can be used to enhance output for the few instruments in that range (organ, contrabassoon, etc.) or they can be used to reduce rumble, acoustic feedback and other low frequency aberrations. A control in what is normally labeled the 60 - 90 Hz area will usually cause the greatest perceptible changes in "bass response".

Total system equalization

Frequency response curves

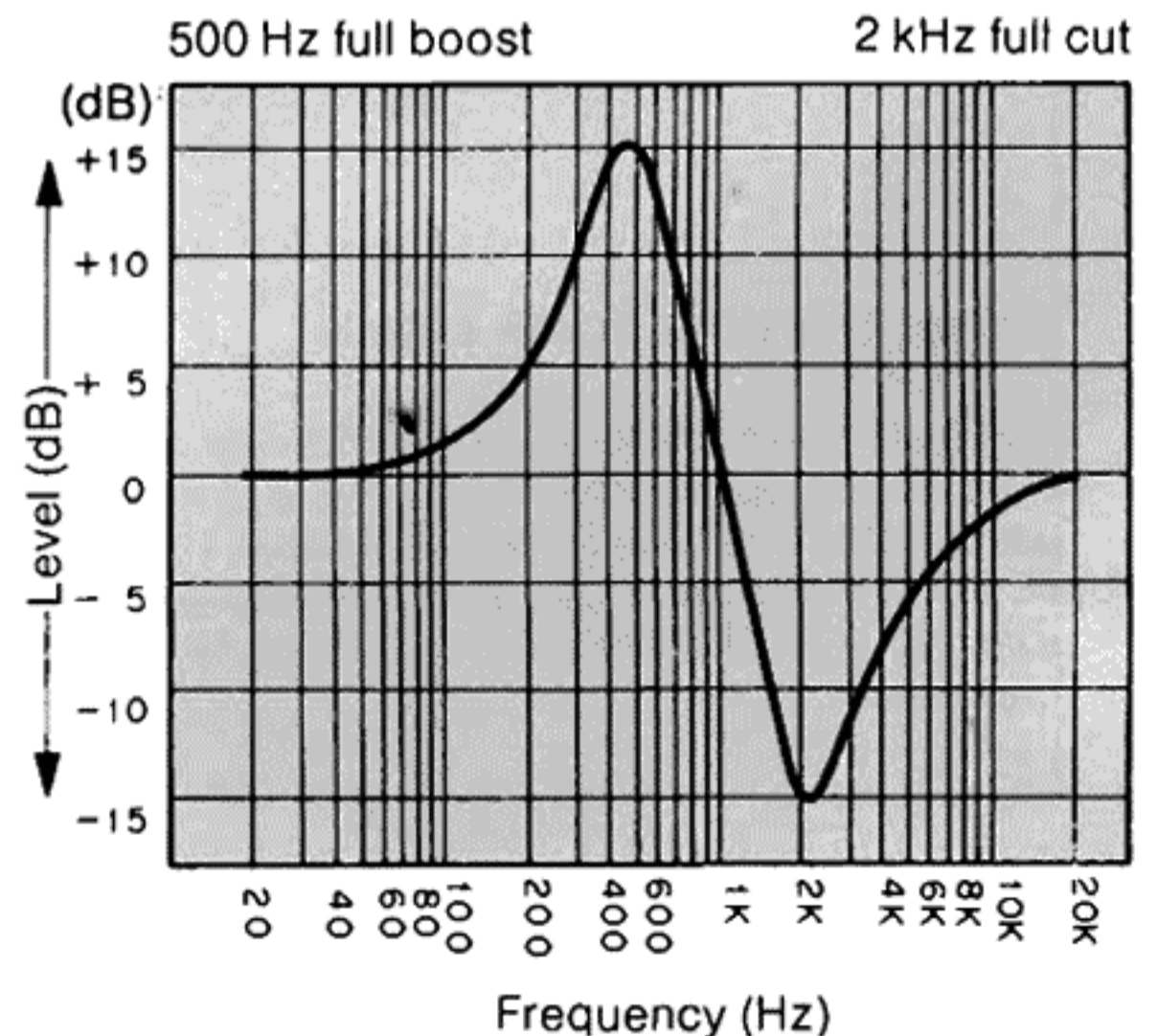
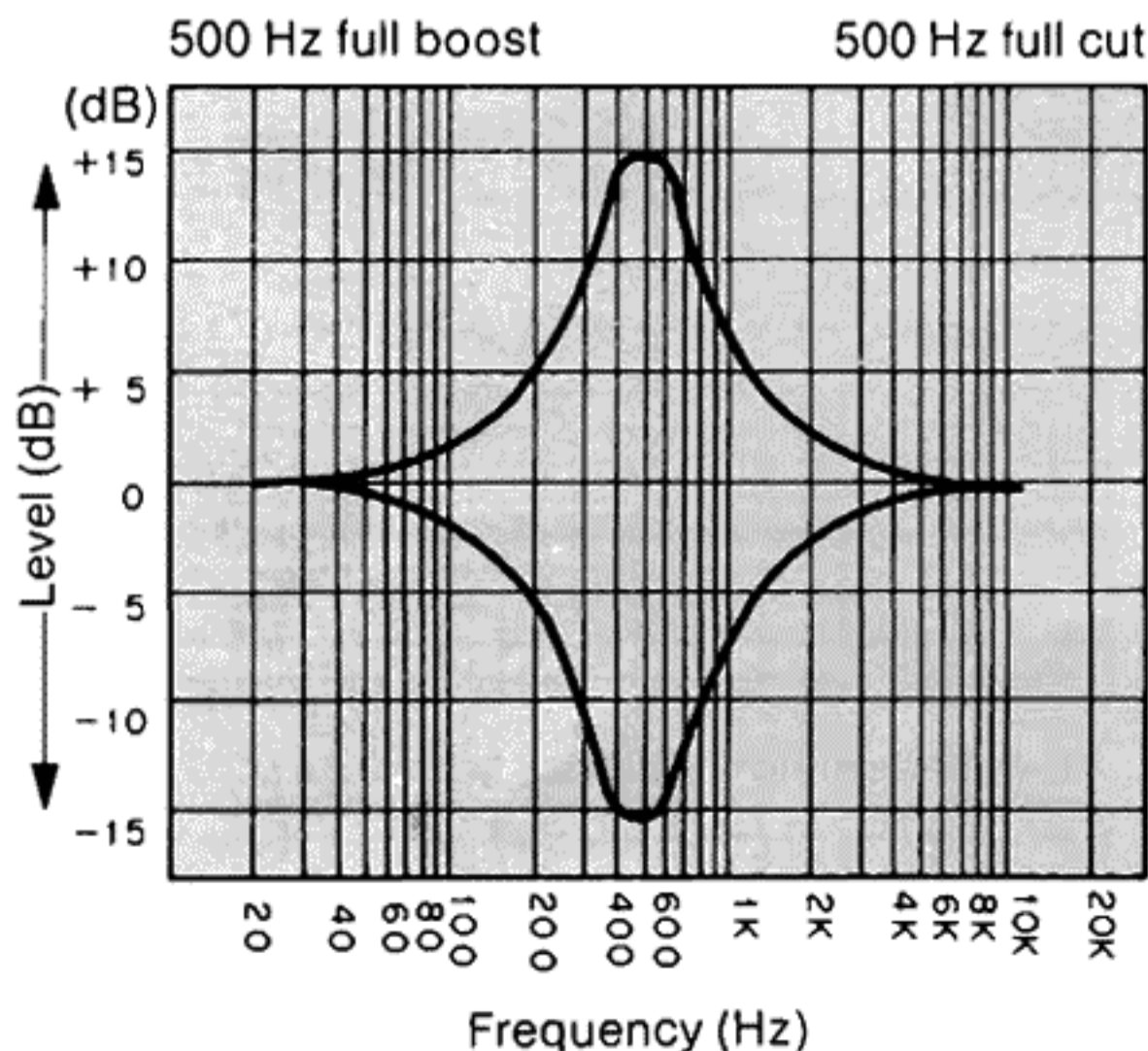

The mid-bass (approx. 140 – 400 Hz). An over accentuated mid-bass region will yield a very muddy and “boomy” quality to the music. A system shy of mid-bass will sound hollow and thin. Controls in this region are important for good overall balance.

The mid-range (approx. 400 – 2,600 Hz). As the area where the ear is most sensitive to tonal balance, the mid-range is important in adjusting the qualitative sonic characteristics of your system. There is controversy among engineers and audiophiles as to what the proper balance should be in this range. Moreover, you will find some settings optimum for certain types of music with other settings just right for different types.

The upper mid-range (approx. 2,600 – 5,200 Hz). Speaker designers often boost output in this range to effect a quality of “presence” to the music. Too much energy, on the other hand, sounds overbearingly harsh and strident. A good balance should be achieved between this and a more muffled sound.

The high end (approx. 5,200 – 20,000 Hz). The region up to only about 12 kHz or so is what is normally perceived as high frequencies. Adjustment in this range affects the brilliance of music, with too much boost in energy yielding an unpleasant and piercing quality.

The last 8,000 Hz contains very little musical material. And most adults have hearing which control in the 14 – 20 kHz range will have a very subtle effect. It can be used to add a little more dimension to the sound or as very high frequency noise filter.

Approximate frequency ranges for musical instruments and voice

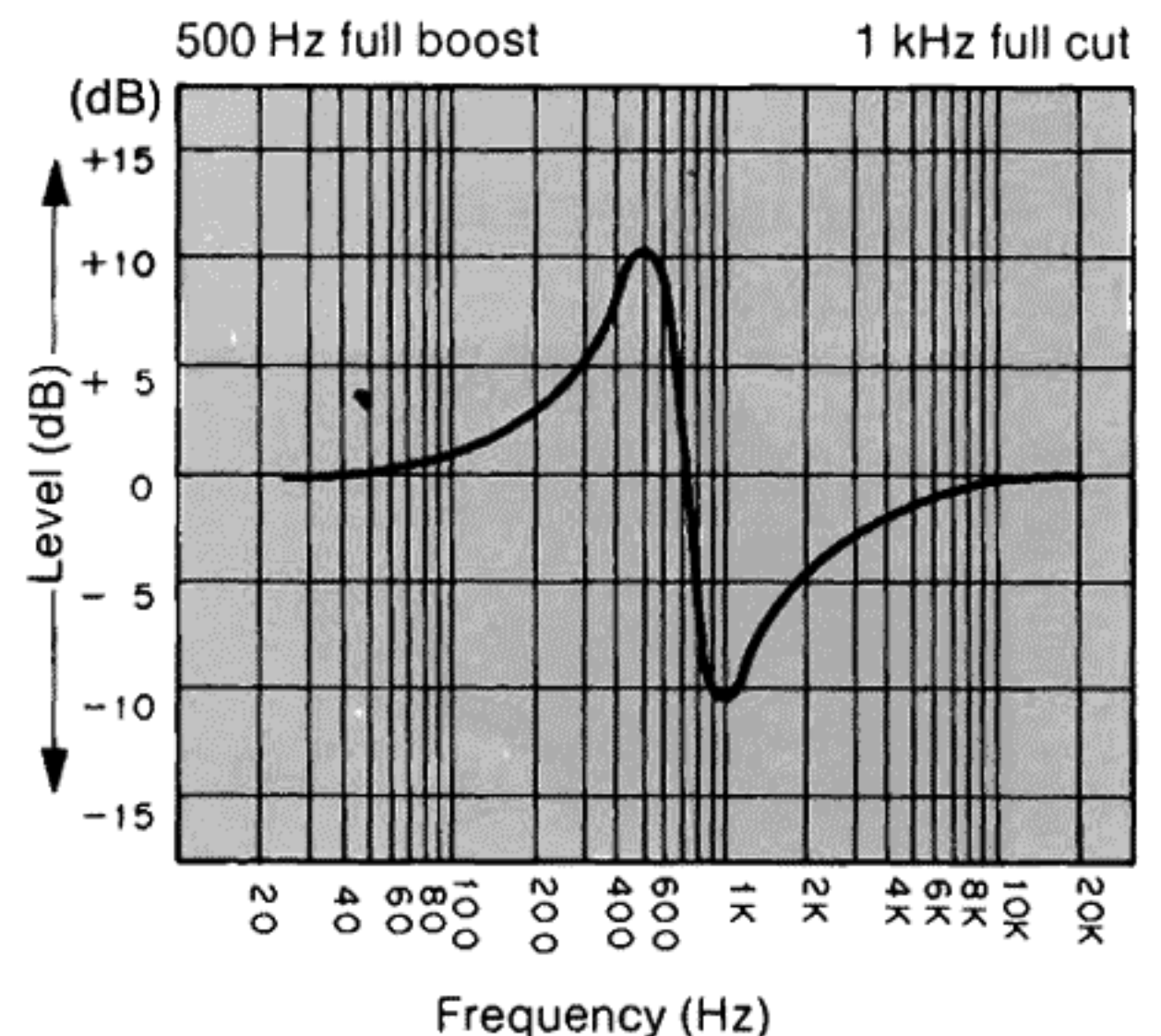
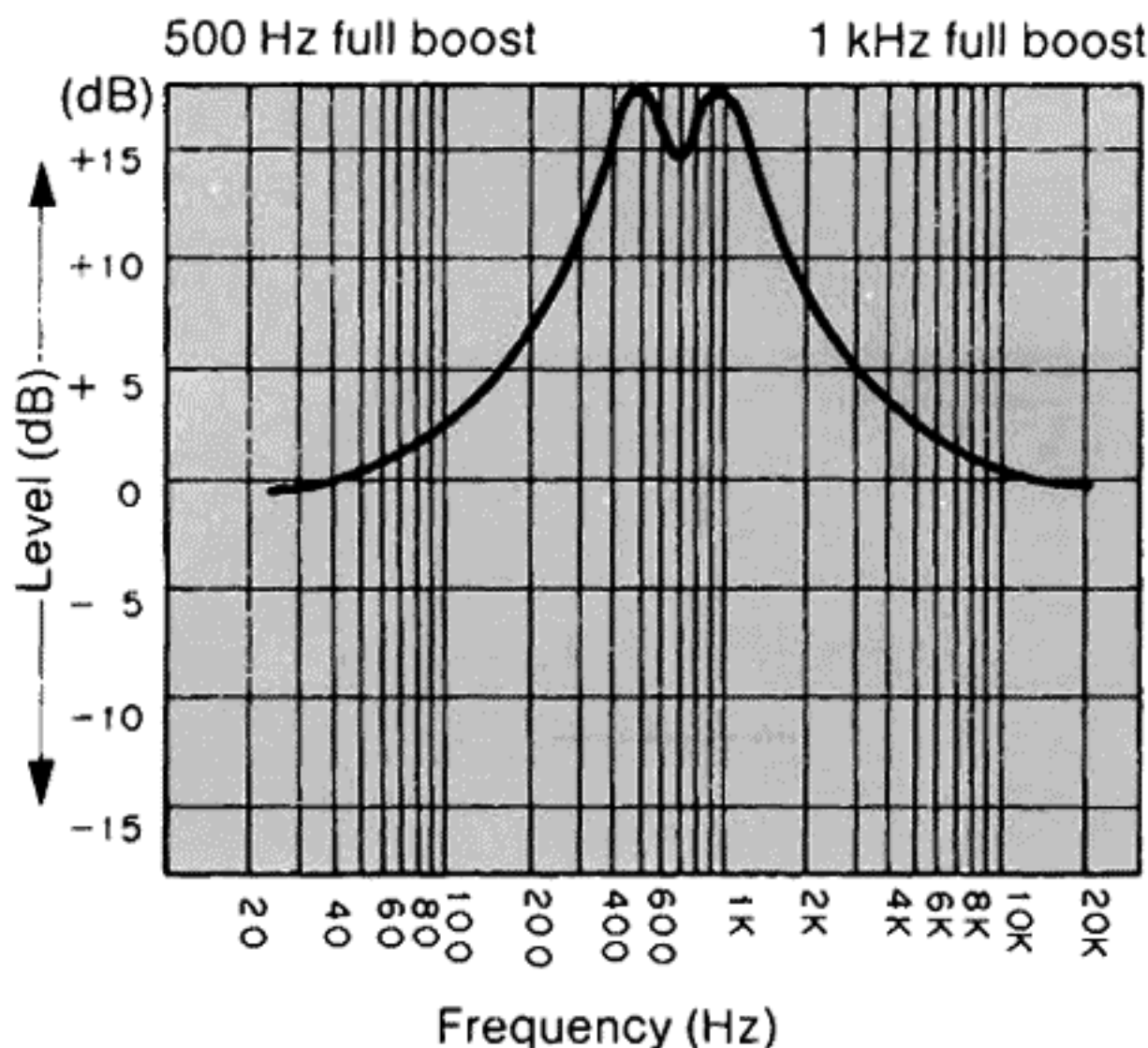
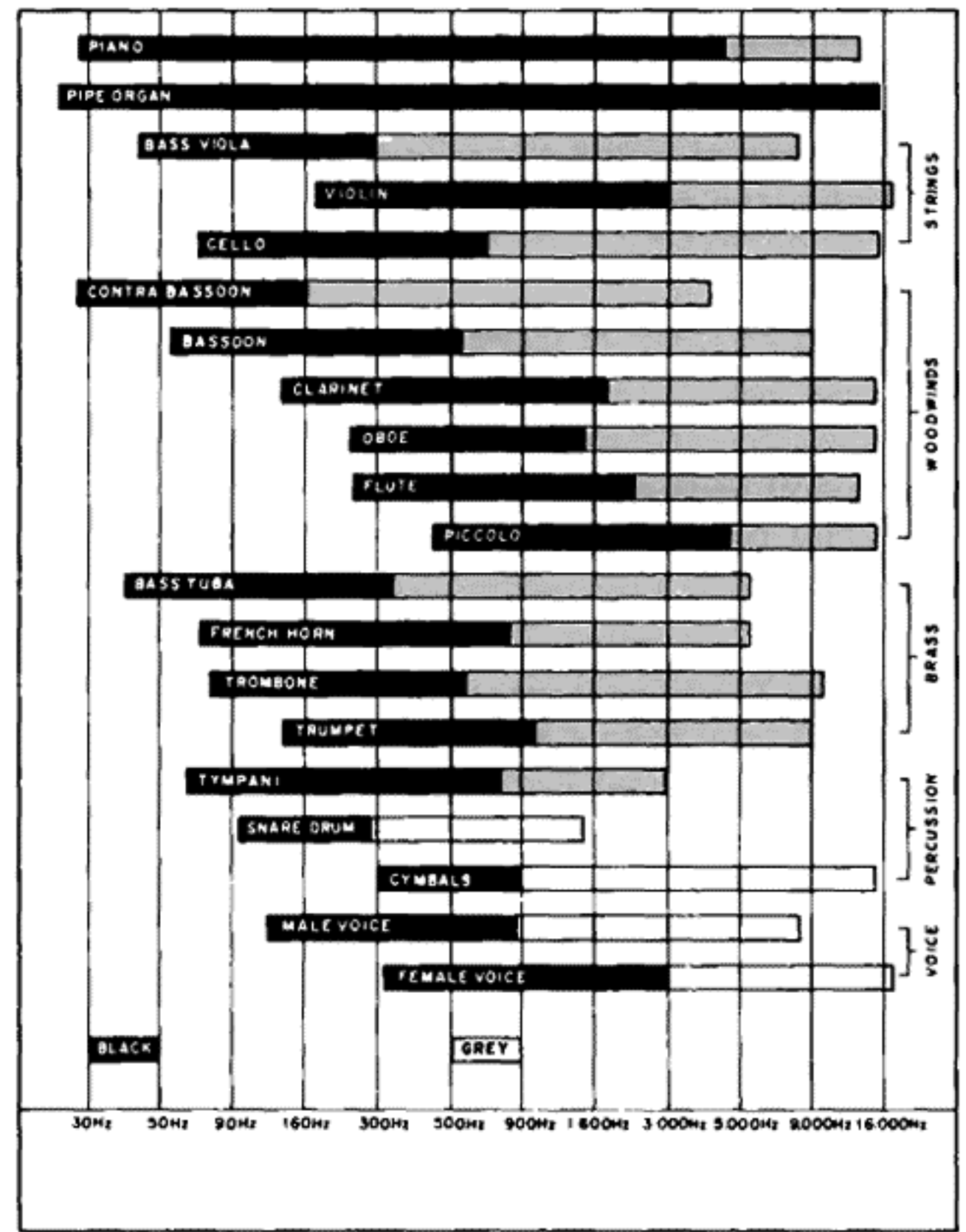

Signal process

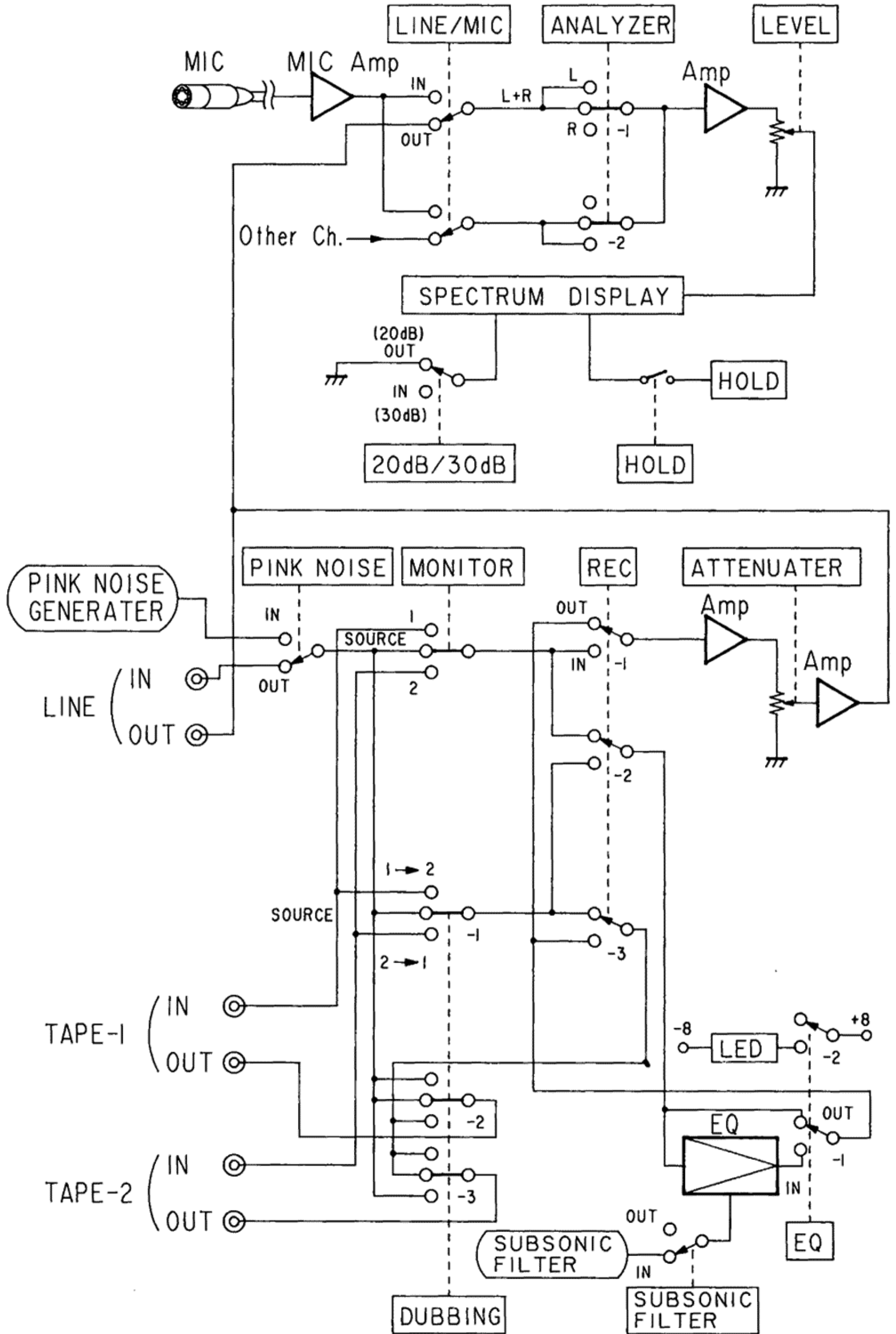

Specifications

Equalizer

Control range	± 15 dB
Frequency response	5 to 100,000 Hz ± 1 dB
Control frequencies	31.5 63 125 250 500 1k 2k 4k 8k 16k (Hz)
Gain (FREQUENCY level controls in FLAT)	± 1 dB unity.
Maximum Input/output level	7V RMS
Harmonic distortion over 20 Hz ~ 20 kHz	0.008% at 1V output
Intermodulation distortion, 60 Hz:7 kHz = 4:1	0.008% at 1V output
Hum and noise A-weighted	-100 dB
Load impedance	10 kohm or greater.
Subsonic filter	-18 dB/octave, 15Hz
Input impedance at 1 kHz	47 kohm.
Output impedance at 1 kHz	600 ohm.

Analyzer

Display accuracy	over 31.5 to 1,000 Hz, ± 10 dB over 2 k to 16 kHz, ± 5 dB
Frequency response from LINE IN	30 to 16 kHz, ± 0.5 dB
Frequency response with microphone supplied	30 to 16 kHz, ± 3 dB
Peakhold duration	continuous
Input impedance, MIC jack	2.2 kohm.
Input sensitivity, MIC jack	0.5 mV
Input sensitivity, LINE IN	150 mV.
Pink noise generator output	100 mV.
Pink noise frequency response	over 20 to 20,000 Hz, ± 2 dB RMS.

Microphone

Element type	Electret condenser.
Directivity	omni-directional.
Impedance, at 1 kHz	2.2 kohm.
Sensitivity	0 dB = 1V/microbar, -70 dB.
Frequency response, compensated	50 to 13,000 Hz.
Bias	1.5V DC supplied by SS-315X.

Miscellaneous

Power requirements	120V, 60 Hz, 20W: USA version 100-120V/220-240V, 50/60 Hz, 20W: PX version 220V, 50 Hz, 20W: Europe version
Dimensions	
width	435 mm, 17-1/8".
height	88 mm, 3-1/2".
depth	222 mm, 8-3/4".
Weight	4.3 kgs, 9-1/4 lbs.

Designs and specifications subject to change without notice.

Limited 1-Year Warranty

ADC warrants this product to be free from defective material and workmanship for a period of one (1) year from original date of purchase. ADC agrees to remedy any such defect or to furnish a new part in exchange for any part of any unit, except stylus (needle) record or battery, whichever is applicable, free of charge for parts and labor, provided unit is delivered by the owner or representative to one of our authorized service agencies with proof of purchase intact for our examination.

- 1 Present your unit to an authorized service agency with proof of purchase.
- 2 Merchandise must be packed carefully in original packing.
- 3 All merchandise must be pre-paid to ADC and will be returned freight paid.

For Return Authorization, call 1-800-447-4700, or write to ADC Products Division, dbx 71 Chapel Street Newton, MA 02195. This warranty does not extend to any of our products which have been subject to misuse, neglect, accident, incorrect wiring not our own, or to use in violation of operating instructions furnished by us, nor extend to any units altered or repaired for warranty defect by anyone other than an authorized service agency.

This warranty does not cover any incidental or consequential damages and is in lieu of all other warranties expressed or implied, and no representative or person is authorized to assume for us any other liability in connection with the sale of our products.

Some states do not allow limitations on how long an implied warranty lasts, and/or exclusion or limitation of incidental or consequential damages, so the above limitations or exclusions may not apply to you. This warranty gives you specific rights and you may also have other rights which vary from state to state.

Above warranty covers U.S. market only. Other areas see separate enclosed warranty.

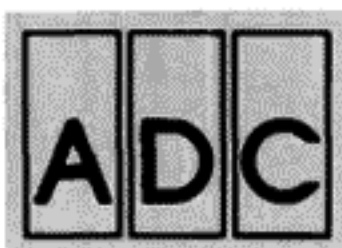

ADC Products Division
dbx
71 Chapel Street
Newton, MA02195 USA

BSR (MANUFACTURING) LIMITED
High Street, Wollaston
Stourbridge, West Midlands
DY8 4PG, U.K.

KTS315XUGX
1185GK
Printed in Japan